

NEW FAMILY OF 150V POWER SCHOTTKY

By F. GAUTIER

INTRODUCTION

Nowadays, the Switch Mode Power Supply (SMPS) is becoming more widespread as a result of computer, telecom and consumer applications.

The constant increase in services (more peripherals) and performance, which offers us these applications, tends to move conversion systems towards higher output power.

In addition to these developments dictated by the market, SMPS manufacturers are in competition, their battlefield being the criteria of power density, efficiency, reliability and cost, this last being factor very critical.

Today, SMPS designers of 12V-24V output have practically the choice between a 100V Schottky or a 200V bipolar diode.

The availability of an intermediate voltage has become necessary to gain in design optimization.

This is why STMicroelectronics is introducing a new family of 150V POWER SCHOTTKY diodes, intended for 12V and more secondary rectification, in applications such as desktops, file servers or adaptors for notebook.

Consequently, this application note will underline the advantages of a 150V Schottky technology compared to a 200V ultra fast diode.

In order to do this, the example of a Flyback converter will be used, and the static and dynamic parameters of the 150V Schottky will be detailed, as well as their influence in this converter.

1. CONDUCTION LOSSES & EFFICIENCY GAIN

Schottky diodes are mainly used for output rectification. In a typical SMPS working with a switching frequency lower than 100kHz, conduction losses are generally the main losses in the diode. They are directly linked to the curve of forward voltage (V_F) versus forward current (I_F), and obviously the best gain in efficiency will be obtained with the lowest V_F .

In the following examples, the conduction losses between a 150V Schottky and a 200V bipolar diode in a Flyback and a Forward converter will be compared.

The conduction losses in the diode are calculated from the classical formula:

$$P_{\text{cond}} = V_{T0} \cdot I_{F(AV)} + R_d \cdot I_{F(RMS)}^2$$

V_{T0} : threshold voltage with $V_{F(@IF)} = V_{T0} + R_d \cdot I_F$

R_d : dynamic resistance with $R_d = \Delta V_F / \Delta I_F$

where V_{T0} and R_d are calculated from the current range of current view by the diode (Fig. 1), for better accuracy.

Figure 1 shows also, the typical current through the rectification diode and the corresponding $I_{F(AV)}$ and $I_{F(RMS)}^2$:

Fig. 1: Typical current through a rectification diode

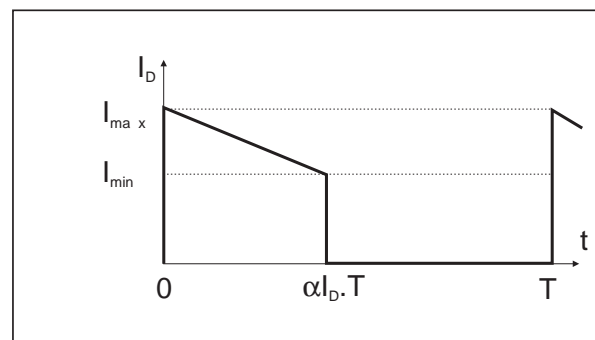

$$I_{F(AV)} = \frac{\alpha_{ID}}{2} (I_{\text{max}} + I_{\text{min}})$$

$$I_{F(RMS)}^2 = \frac{\alpha_{ID}}{3} (I_{\text{max}}^2 + I_{\text{min}}^2 + I_{\text{max}} \cdot I_{\text{min}})$$

$$R_d = \frac{V_{F(@I_{\text{max}})} - V_{F(@I_{\text{min}})}}{I_{\text{max}} - I_{\text{min}}} \quad V_{T0} = V_{F(@I_{\text{max}})} - R_d \cdot I_{\text{max}}$$

NB:

-In the datasheet, the V_{T0} and R_d are maximum values given for I_F and $2 I_F$ at 125°C.

-In discontinuous mode $I_{\text{min}}=0$.

APPLICATION NOTE

1.1. Example 1: FLYBACK

The first example is a 24V/48W Flyback converter working in continuous mode ($V_{mains}=90V$) with the following conditions:

$$\alpha_{ID} = 0.4, I_{max_{ID}} = 6.66A, I_{min_{ID}} = 3.33A, I_{out} = 2A$$

Fig. 2: Rectification diode in a Flyback converter

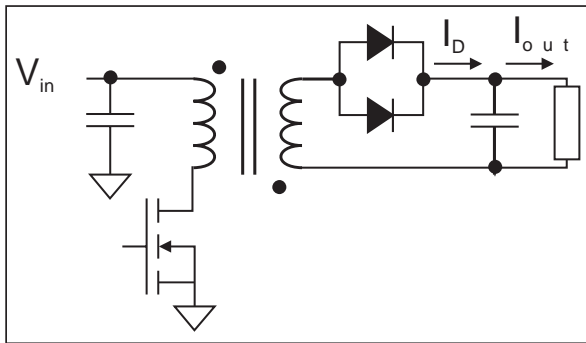

Calculations per diode give:

$$I_{F(AV)}_{per\ diode} = 1A \text{ and } I_{F(RMS)}_{per\ diode} = 1.6A$$

We can now calculate the efficiency gain ($\Delta\eta(\%) = \eta_{ref} - \eta$) for this Flyback converter which has a reference (ref) efficiency of 85% with STPR1020CT:

Fig. 3: Example of efficiency gain in Flyback converter

$P_{out}=48W$ $V_{out}=24V$	V_{T0} typ(V)	R_d m Ω	P_{cond} (W)	ΔP (W)	$\eta=85\%$
	1.5A, 3A, 125°C				$\Delta\eta\%$
STPR102CT 2x5A / 200V PN diode	0.58	46.5	1.4	0 (ref)	0 (ref)
STPR162CT 2x8A / 200V PN diode	0.54	46.5	1.32	-0.08	+0.12
STPS10150CT 2x5A / 150V Schottky diode	0.50	43	1.22	-0.18	+0.27
STPS16150CT 2x8A / 150V Schottky diode	0.47	40	1.14	-0.26	+0.39

1.2. Example 2: FORWARD

In the following example, the conduction losses in a 12V/96W Forward converter are simulated:

Fig. 4: Rectification diode in a Forward converter

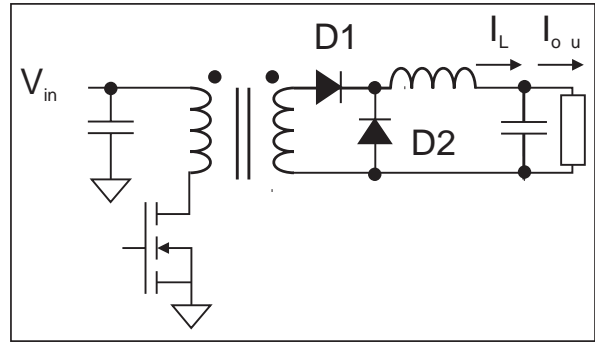

$$\alpha_{D1} = 0.3, I_{Lmax} = 9A, I_{Lmin} = 7A, I_{out} = 8A$$

Calculations per diode give:

$$I_{F(AV)D1} = 2.4A, I_{F(RMS)D1} = 4.39A$$

$$I_{F(AV)D2} = 5.6A, I_{F(RMS)D2} = 6.71A$$

The difference of efficiency between a STPR1620CT (2x8A, 200V Ultrafast) and a STPS16150CT (2x8A, 150V Schottky) for a 12V output, are given in table Fig. 5:

Fig. 5: Example of efficiency gain in Flyback converter

$P_{out}=96W$ $V_{out}=12V$	V_{T0} typ(V)	R_d m Ω	P_{cond} (W)	ΔP (W)	$\eta=85\%$
	7A, 9A, 125°C				$\Delta\eta\%$
STPR1620CT	0.8	20	6.48	Ref	Ref
STPS16150CT	0.68	20	5.60	-0.95	+0.72

These two examples show that whatever the type of converter, a significant efficiency gain can be achieved only by replacing a 200V bipolar diode by a 150V Schottky.

2. REVERSE LOSSES AND T_{JMAX}

2.1. Reverse losses: Prev

The reverse losses can be determined by:

$$P_{rev} = V_R \cdot I_R \cdot (1 - \alpha)$$

with:

(1-α): duty cycle when the reverse voltage (V_R) is applied

I_R: leakage current versus V_R and operating junction temperature (T_j)

V_R: reapplied voltage accross the diode

Fig. 6 shows an example of reverse losses in a Flyback converter with the following conditions:

$$(1 - \alpha) = 0.4, V_R = 80V, T_j = 125^\circ C$$

Fig. 6: Example of reverse losses in a Flyback converter

	I _{Rtyp} per diode 100V, 125°C	P _{rev} per diode
STPS10150CT	130µA	4.2mW

Thus, the reverse losses are very low due to the low value of the leakage current.

The following paragraph will show that due to these low values of reverse current, the thermal runaway limit is only reached for high junction temperature.

2.2. T_{jmax} before thermal instability is reached

Remembering that the stability criterion is given by:

$$\frac{dP_{rev}}{dT_j} < \frac{1}{R_{th(j-a)}}$$

with:

$$P_{rev} = V_R \cdot I_{R(V_R, T_{jmax})} \cdot (1 - \alpha)$$

The above formulae give the critical value of the leakage current before the thermal runaway limit is reached:

$$I_{R(V_R, T_{jmax})} = \frac{1}{V_R \cdot c \cdot R_{th(j-a)} \cdot (1 - \alpha)}$$

The evolution of the leakage current versus T_j and V_R is given by:

$$I_{R(V_R, T_j)} = I_{R(V_R, 125)} \exp^{c(T_j - 125)}$$

From these physical laws, it can be deduced that:

$$T_{jmax} = 125 + \frac{1}{c} \cdot \ln \frac{I_{R(V_R, T_{jmax})}}{I_{R_{max}(V_R, 125^\circ C) \text{ datasheet}}}$$

Example:

Flyback converter with 2 diodes in parallel

$$(1 - \alpha) = 0.4, c = 0.069, V_R = 80V$$

$$R_{th(j-c)total} = 2.4^\circ C / W, R_{th(c-a)} = 7.6^\circ C / W$$

Fig. 7: Example of T_{jmax} with STPS10150CT

For a dual diode	I _{Rmax} (80V, 125°C)	I _{R(VR, Tjmax)}	T _{jmax}
STPS10150CT	1.3mA	45.28mA	176.5°C

This example shows that in a typical application, a 150V Schottky can be used up to 175°C. STMicroelectronics specifies in the datasheet T_{jmax} at 175°C.

3. SWITCHING BEHAVIOUR

3.1. Turn-on behaviour

The behaviour at turn-on is characterized by a low value of peak forward voltage (V_{FP}) and forward reverse recovery time (t_{fr}) (Fig. 8).

Fig. 8: V_{FP} and t_{fr} for STPS16150CT

I _F =16A dI _F /dt=100A/µs T _j =25°C Per diode	t _{fr} (ns)	V _{FP} (V)
STPS16150CT	100	2.2

These values depends mainly on the dI_F/dt. The switching losses at turn-on are always negligible.

3.2. Turn-off behaviour

The turn-off behaviour is a transitory phenomenon (ns), but repetitive depending on the switching frequency. It is a source of spike voltage, noise and for high switching frequency, of non-negligible switching losses.

In order to illustrate this phenomenon, the example of a Flyback converter will be used once again.

The difference in behaviour between a 150V Schottky and 200V bipolar diode will be compared for the three following points: spike voltage, EMC and switching losses.

APPLICATION NOTE

3.2.1. Difference of spike voltage between a 150V Schottky and 200V PN diode

In a Flyback converter, the reverse voltage (V_R used in §2) across the diode will be maximum, for the maximum mains voltage (V_{INmax}):

$$V_R = V_{INmax} \cdot \frac{n_s}{n_p} + V_{out} \quad (\text{cf Fig. 9})$$

In addition to this nominal reverse voltage (V_R), generally an overvoltage spike at the turn-off of the diode is observed (Fig. 9). It can be shown that with a conventional bipolar diode, this spike is more important for a Flyback converter working in continuous mode than in a discontinuous mode.

In the case of a high spike voltage, the Maximum Repetive Reverse Voltage (V_{RRM}) of the diode has to be oversized, compared with the real need (V_R) defined in Fig. 9.

To limit this peak and to preserve a "guard band" with the V_{RRM} (in order to avoid reaching the breakdown voltage), the designer places a snubber circuit (R_s, C_s) in parallel with the diode.

Generally, the "guard band" is such that the maximum voltage reapplied to the diode does not exceed 80% of the V_{RRM} .

Fig. 9: Spike voltage across the rectification diode

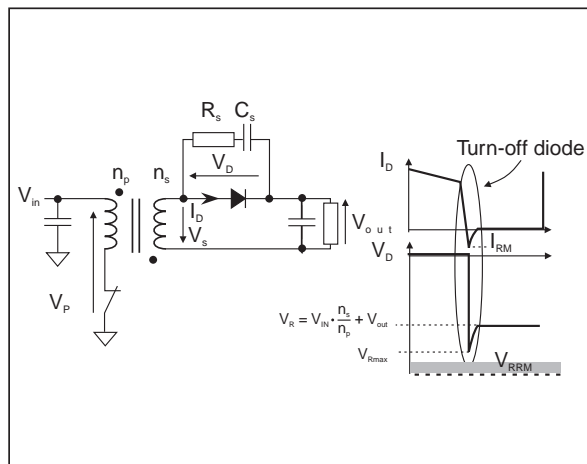

This spike voltage is due to the leakage inductance of the transformer (L_f) and to the nature of the recovery charge of the diode, which itself depends on the diode technology: bipolar diode or Schottky diode.

3.2.1.1 Turn-off behaviour for a PN diode

In the datasheet are specified the main turn-off parameters ($Q_{rr}, I_{RM}, t_{rr}...$). These parameters are represented in Fig. 10:

Fig. 10: Key parameters at turn-off for a bipolar diode without snubber

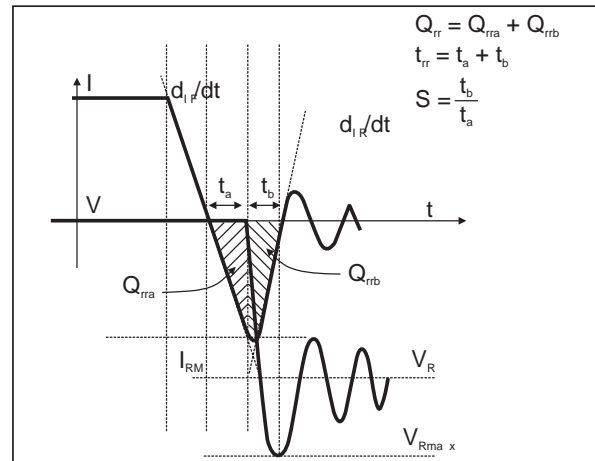

The following oscillogram shows the turn-off behaviour for a bipolar diode (STPR1620CT) with snubber and without snubber, in a 24V/45W Flyback working in continuous mode.

To observe the phenomenon correctly, it is necessary to compensate the delay time between the voltage and the current, (by temporal shift) due to the measuring equipment Fig. 11.

Fig. 11: Switching behaviour of a 200V bipolar diode

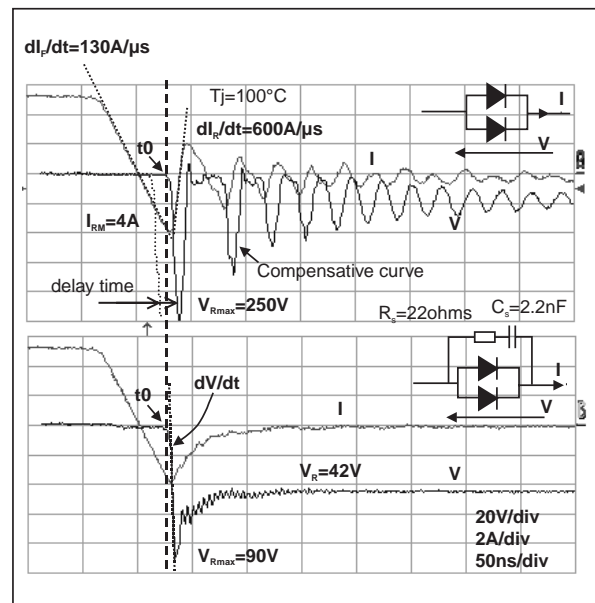

Without a snubber, in this example the diode is repeatedly in conduction because the oscillation is very strong. Furthermore, the voltage is close to the breakdown voltage. This means that the system is no longer reliable and a snubber circuit is necessary.

On these 2 oscillograms, we can see that the value of the maximum reverse current (I_{RM}) is defined when the reverse voltage rises (typical behaviour of a bipolar diode). At this time the voltage is not fixed by the diode.

The curve Q_{rr} , I_{RR} versus di_F/dt and T_j is given in the datasheet. For example in Fig. 12, the evolution of I_{RM} versus di_F/dt for a STPR1620CT can be observed.

Fig. 12: Peak reverse recovery current versus di_F/dt (per diode)

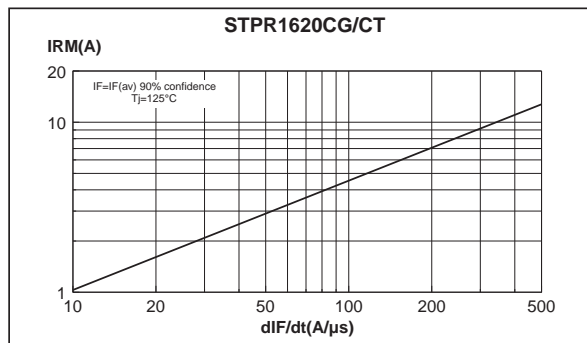

It can be also noticed, that the parameter I_{RM} significantly increases with the temperature.

In continuous mode the di_F/dt (few hundred $A/\mu s$) is fixed by the leakage inductance and the reverse voltage (V_R):

$$\frac{di_F}{dt} = \frac{V_R}{L_f} \quad \text{with} \quad V_R = \frac{n_s}{n_p} \cdot V_{IN} + V_{out}$$

It is many time higher than in discontinuous mode (lower than $1A/\mu s$):

$$\frac{di_F}{dt} = \frac{V_{out}}{L_s + L_f} \quad \text{with} \quad L_s \gg L_f$$

(L_s : Secondary inductance)

Thus, with this curve we can see that, in continuous mode (high di_F/dt), the bipolar diode must evacuate a non-negligible charge, which means a higher I_{RM} . This is verified on oscillogram Fig. 11.

With this value of I_{RM} , an equivalent model at t_0 with a snubber circuit can be established:

Fig. 13: Equivalent model at t_0 for a bipolar diode

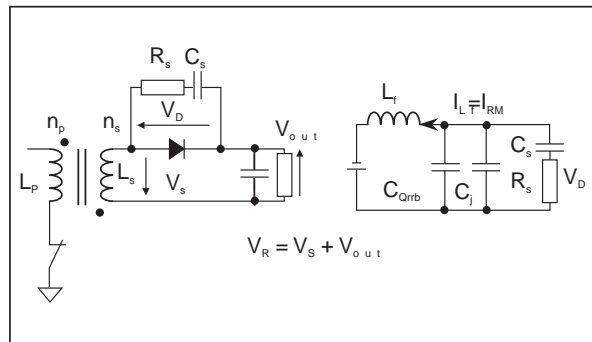

Where:

V_s : secondary voltage $V_s = \frac{n_s}{n_p} \cdot V_{IN}$

L_f : leakage inductance of the transformer

C_j : junction capacitance

C_{Qrrb} : equivalent capacitance modeling the reverse charge, necessary for the establishment of the potential barrier, which supports the reverse voltage.

V_{out} : output voltage

With the following initial conditions at $t=t_0$:

$$I_{L_f} = I_{RM, \text{bipolar}} \quad \text{and} \quad V_D \approx 0$$

The equivalent schematic can be used to define $V_D = V_{R, \text{max}}$

NB:

1) Without snubber, there is a L_f, C circuit ($C = C_j + C_{Qrrb}$) which lead to a second order differential equation:

$$\frac{d^2 V_C}{dt^2} + \omega_0^2 \cdot V_C + \omega_0^2 \cdot V_R = 0 \quad \text{and} \quad \omega_0^2 = 1/L_f \cdot C$$

with initial conditions at $t=t_0$:

$$I_{L_f} = I_{RM} \quad \text{and} \quad V_{C_0} = V_D = 0$$

In this equation, an approximation is made with C constant, because in reality C_j and C_{Qrrb} vary with the voltage applied.

The solution of the differential equation gives us:

$$V_{R, \text{max}} = V_D = V_R + \sqrt{V_R^2 + \left(I_{RM} \cdot \sqrt{\frac{L_f}{C}} \right)^2}$$

Therefore we can see that the $V_{R, \text{max}}$ depends the leakage inductance (L_f) and on recovery charge (I_{RM}). Thus, $V_{R, \text{max}}$ is very dependent on the temperature.

APPLICATION NOTE

If C is a low value of capacitance, the expression leads to a first order differential equation:

$$V_{R_{max}} = V_D = V_R + L_f \cdot di_R / dt$$

with:

$$di_R / dt = I_{RM} / t_b \text{ and } t_b = Q_{rrb} / (I_{RM} / 2)$$

$$di_R / dt = I_{RM}^2 / (2 \cdot Q_{rrb})$$

If the diode is of a snap-off type, we have $t_b \rightarrow 0$, $Q_{rrb} \rightarrow 0$ and di_R/dt is very high, consequently $V_{R_{max}}$ is considerable. There is a risk to reach the breakdown voltage of the diode. (It is not guaranteed by the manufacturer)

2) With a snubber, if it is supposed that $C_S \gg C_j + C_{Qrrb}$ (more true for an ultrafast PN diode), we have a simple R_s, L_f, C_S circuit to define by the second order differential equation:

$$\frac{d^2 V_{C_S}}{dt^2} + 2m\omega_0 \frac{dV_{C_S}}{dt} + \omega_0^2 \cdot V_R = \omega_0^2 \cdot V_R$$

where:

m: the absorption coefficient $m = \frac{R_s}{2} \sqrt{\frac{C_S}{L_f}}$

ω_0 : natural frequency $\omega_0 = \frac{1}{\sqrt{L_f \cdot C_S}}$

There are 3 possible cases:

- **$m > 1$** behaviour without oscillation (over damping)

- **$m < 1$** behaviour with oscillation damped (under damping), where the frequency oscillation can be determined by:

$$\omega_r = \omega_0 \sqrt{1 - m^2}$$

- **$m = 1$** limit of behaviour without oscillation (critical damping)

Like this, in this case, it is possible to suppress the oscillation across the diode with $m > 1$.

3.2.1.2 Turn-off behaviour for a Schottky diode

For an ideal Schottky diode, there is no recovery charge ($Q_{rr}=0$). Therefore, it is said that the diode has a capacitive type recovery Fig. 14.

Fig. 14: Turn-off for a perfect Schottky diode without snubber

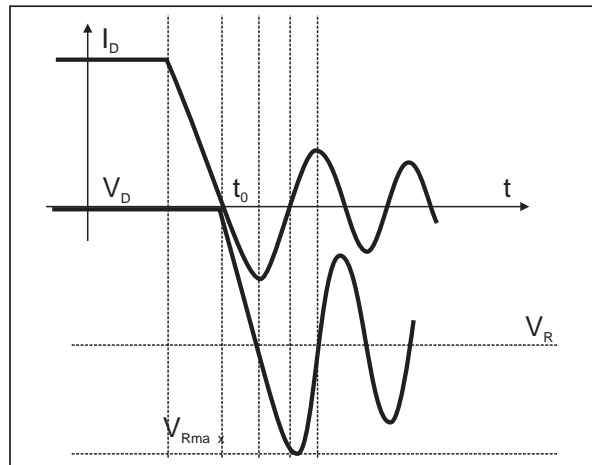

In this perfect case at $t=t_0$, we have:

$$L_f \cdot di_R / dt = 0 \text{ and } V_D \approx 0$$

Without a snubber circuit, the new solution of the differential equation gives:

$$V_D = V_{R_{max}} = 2 \cdot V_R$$

Unfortunately, it is difficult to realize a perfect high voltage Schottky. The reason is the presence of a parasitic bipolar diode in parallel with the Schottky. If it is polarized, the recovery charge is added at the turn-off. The phenomenon begins to appear for a 100V technology.

In the same conditions as before, the STPS16150CT is used:

Fig. 15: Switching behaviour of a STPS16150CT

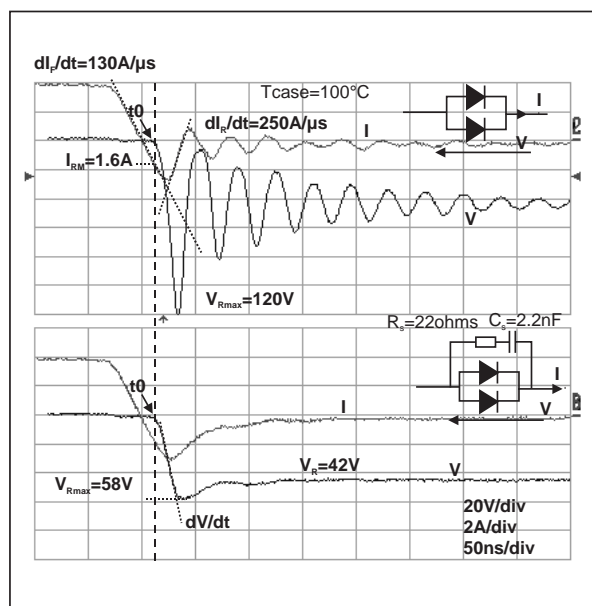

It can be observed that this is not an ideal Schottky. In fact, when the voltage rises at , we have a value of I_{RM} . The charge Q_{rrB} is not easily identifiable because it is embedded in the capacitive current.

However, the slope dl_R/dt can be observed.

Unlike a PN diode, we can see that with the 150V Schottky the maximum reverse voltage (V_{Rmax}) and the maximum reverse current (I_{RM}) are distinctly lower.

The equivalent model at t_0 for a STPR1620CT and a STPS16150CT is the same, with the lower initial conditions at t_0 :

$$I_{L_t} = I_{RM_schottky} \quad \text{and} \quad V_D \approx 0$$

In Fig. 16, we can see the curve C_j versus V_R for the 200V bipolar and 150V Schottky diode. Whatever the reverse voltage, the junction capacitance of the 150V Schottky is always higher than for a PN diode. This justifies, the lower observed with the Schottky diode.

Fig. 16: C_j versus V_R

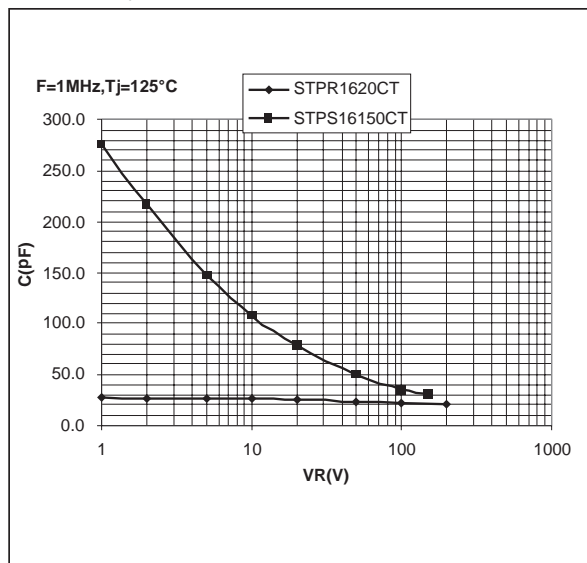

In summary, when we compare the different parameters with those of the bipolar diode, we have:

$$I_{RM_bipolar} > I_{RM_schottky}$$

$$C_{j_bipolar} < C_{j_schottky}$$

$$(dl_R / dt)_{bipolar} > (dl_R / dt)_{schottky}$$

$$(dV / dt)_{bipolar} > (dV / dt)_{schottky}$$

$$V_{Rmax_bipolar} > V_{Rmax_schottky}$$

Thus, a different efficiency of the snubber circuit with a bipolar diode and a Schottky diode is observed. In most cases, we can say that the 150V Schottky behaves better at turn-off, due to its larger capacity and its softness recovery.

Model showed in Fig. 13 can be used to define the snubber circuit.

NB:

In the case of a Forward converter with multiple outputs (12V, 5V, 3.3V...) and cross regulation with coupled inductor, the poor behaviour at the turn-off with a bipolar diode on 12V output, will be reflected on the other coupled outputs (that means an overvoltage on rectification diode of 5V output). A 150V Schottky will decrease the coupled effects.

3.2.2. EMC Comparison between a 150V Schottky and a 200V bipolar diode

The better the behaviour at turn-off of the 150V Schottky in comparison with a 200V bipolar diode, the better performance in the EMC.

Fig. 16 shows the comparison of electromagnetic disturbance conducted in a 45W/24V Flyback converter (in continuous mode) between a STPR1620CT and a STPS16150CT with a snubber circuit.

Fig. 17: Electromagnetic disturbances conducted between a STPR1620CT and a STPS16150CT

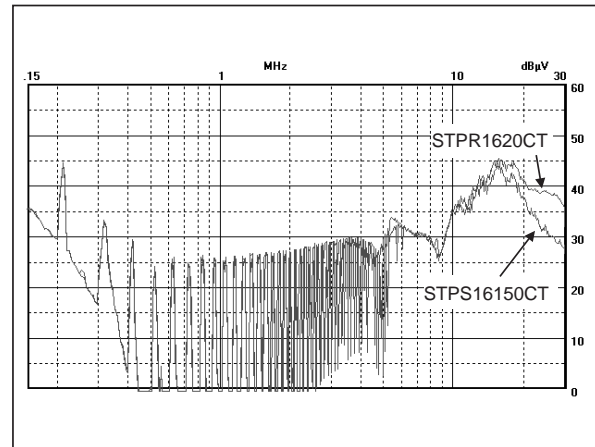

We can see near 30MHz, that there is a difference of -10dB. This difference is partially explained by the higher dV/dt with a bipolar diode at turn-off than with a 150V Schottky. In fact, the lower capacitance junction of the PN diode favors the high dV/dt at t_0 , and therefore the common current mode. ($i_{CM} = C \cdot dV / dt$, C equivalent capacitance junction-heatsink)

The other high dV/dt , which could take place due to the strong oscillation, are suppressed by a good choice of the snubber circuit.

APPLICATION NOTE

In the case of an EMC problem, the first solution is to reduce the current slope (di/dt) by adding a gate resistance (R_G about 10 ohms). In this way, I_{RM} and di/dt decrease as well as the $V_{R,max}$.

3.2.3. Switching losses

We have evaluated the consequences of poor behaviour at the turn-off: spike reverse voltage, possible oscillations and EMC problem. For these reasons, the designer may wish to use a soft recovery PN diode, but which, in return, will increase the switching time and particularly the switching losses at turn-off.

Switching losses at turn-off due to the diode are the sum of losses inside the diode and the energy dissipated in the other elements of the circuit. In fact, during this time the I_{RM} current, due to the recovery charge, flows through the transformer, the power MOS transistor and the primary bulk capacitor. Thus, there are additional losses. The distribution of power losses at turn-off can be detailed:

- Losses inside the diode:

$$P_{\text{turn-off diode}} = \frac{1}{2} \cdot t_b \cdot I_{RM} \cdot V_R \cdot F$$

- Losses due to the energy store in the leakage inductance:

$$W_{L_f} = \frac{1}{2} \cdot L_f \cdot I_{RM}^2$$

which is mainly dissipated in the snubber resistor (R_s).

- Losses due to the eddy current in the transformer (view AN1262)

- Losses due to the all additional resistor of circuit, defined by:

$$P_{\text{turn-off}_R} = I_{RMS(IRM)}^2 \cdot \sum R$$

As described before (in §1), in a typical converter working with a switch frequency lower than 100kHz, these different losses can be considered negligible compared to the conduction losses.

However in applications such as the DC/DC converter (12V-48V) working with a switching frequency around 300kHz, these losses can be predominant, and a 150V Schottky can be very interesting to reduce the switching losses.

4. RESULT OF EXPERIMENTS

Experimental measurements (Fig. 18) were carried out in a 45W/24V Flyback converter working in the following conditions:

$$V_{IN} = 90V \quad P_{out} = 45W \quad V_{out} = 24V$$

$$F_s = 100kHz \quad T_c = 100^\circ C$$

These experiments confirm the interest in a 150V Schottky in comparison with a 200V bipolar diode.

Fig. 18: Experiments of efficiency in a Flyback converter

	$\eta\%$	$\Delta P(W)$
STPR1620CT (2x8A)	84.04	0.41
STPS16150CT (2x8A)	84.4	0.18
STPS20150CT (2x10A)	84.69	Ref

CONCLUSION

We have been able to highlight that when we have the choice between 150V Schottky and 200V PN diode, the 150V Schottky is the best choice for the safety of the component and the environment, the limitation of parasitic effects and for the efficiency of the converter.

In fact, in addition to the low V_F , the 150V Schottky has a better switching behaviour, due to its essentially capacitive recovery (less sensibility to the temperature). We have the advantage of a soft recovery diode in terms of EMC and the Schottky is preferable to a fast recovery diode in terms of losses. The 150V Schottky diode is the better choice versus the 200V bipolar as for EMC and losses at turn-off are concerned. Experimental measurements confirm this.

Moreover, future advancements will mean that this product will be developed.

In fact, with the arrival of the EN6100-3-2 standard and the introduction of the PFC, whatever the input voltage is, there will be a continuous voltage on the primary. This will lead to a reduction of the transformation ratio, and in the same time, the reverse voltage of the diode.

Consequently, a lower breakdown voltage diode will be needed in the future to replace a 200V PN diode used today.

Also, the tendency is for the output power of adaptors to increase. This involves an increase in the output voltages. The voltage requirements of the diode in this case will be higher than 100V and a 150V diode is likely to be the appropriate component.

Information furnished is believed to be accurate and reliable. However, STMicroelectronics assumes no responsibility for the consequences of use of such information nor for any infringement of patents or other rights of third parties which may result from its use. No license is granted by implication or otherwise under any patent or patent rights of STMicroelectronics. Specifications mentioned in this publication are subject to change without notice. This publication supersedes and replaces all information previously supplied. STMicroelectronics products are not authorized for use as critical components in life support devices or systems without express written approval of STMicroelectronics.

The ST logo is a registered trademark of STMicroelectronics

© 2001 STMicroelectronics - Printed in Italy - All rights reserved.

STMicroelectronics GROUP OF COMPANIES

Australia - Brazil - China - Finland - France - Germany - Hong Kong - India - Italy - Japan - Malaysia
Malta - Morocco - Singapore - Spain - Sweden - Switzerland - United Kingdom - U.S.A.

<http://www.st.com>





LittleDiode supplies new, hard to find or obsolete electronic components and semiconductors all over the world.

With over two million different components listed you are sure to find the part you need.

Feel free to visit us today at our online store:

LittleDiode.com

Looking forward to providing you with the best possible service.