



1. INTRODUCTION

In this document, we explain the software of an Electronic thermostat bread board. The demonstration kit has been developed by STMicroelectronics and is available under THERM01EVAL reference.

This board illustrates the operation of a low-cost electronic thermostat for 220-240V 50Hz cold appliances, including STMicroelectronics ACS102-5TA, ACST6-7ST and ST62 devices.

The microcontroller will ensure four functions:

- Temperature regulation (temperature capture through NTC resistor + Hysteresis regulation).
- Compressor monitoring: the motor is controlled depending on fridge temperature. To start it, the starting triac T_s and the run triac T_r are triggered simultaneously for 500ms. Then, only the run triac will continue to conduct.
- Overcurrent detection: this is based on the measure of the peak current using a shunt resistor. During the one second (500ms+500ms) of starting transient, this routine does not run.
- Internal light bulb control.

2. HARDWARE CONFIGURATION

2.1 General information

The power supply of the microcontroller is a capacitive one. Its particularity is that the V_{SS} is 5V less than the Neutral. This power supply can be called a "negative supply". This generates flowing out current from the ACS/ACST gates (ACS are triggered only with a negative gate current). This feature must also be kept in mind when the overcurrent detection is implemented. It will define in which polarity the current can be sensed.

The following figure gives the board electrical circuit.

Table 1: Port B configuration registers

Pin Name	USE	DDR	OR	DR
PB0	Not used	0	0	0
PB1	Switch ON the LED / Switch OFF the LED	1	1	0 / 1
PB2	Not existing for ST6200	0	0	0
PB3	SHUNT voltage Analog Input / Input with pull-up	0	1 / 0	1 / 0
PB4	Not existing for ST6200	0	0	0
PB5	Temperature order Analog Input / Input with pull-up	0	1 / 0	1 / 0
PB6	Door switch information	0	0	0
PB7	Cabinet temperature Analog Input / Input with pull-up	0 / 0	1 / 0	1 / 0

All port A pins are configured as push-pull outputs. Table 2 details the option choices and configuration registers.

Table 2: Port A configuration registers

Pin Name	USE	DDR	OR	DR
PA1	START ACST6 ON / START ACST6 OFF	1	1	0 / 1
PA2	RUN ACST6 ON / RUN ACST6 OFF	1	1	0 / 1
PA3	LIGHT BULB ON / LIGHT BULB OFF	1	1	0 / 1

3. MAIN PROGRAM

3.1 Mains period measurement

As the board does not embed an oscillator or resonator, the internal resonator of the MCU is used to achieve the clock. But, in this case, the running frequency is given within a range of 20 %. This is not enough to ensure an optimum pulse gate current control with a power consumption as little as possible.

To increase the timer accuracy, the MCU uses the Zero Voltage Crossing (ZVC) events to have time information. The LINE voltage is connected to the NMI pin through a high impedance resistor. An interruption will then occur at each ZVC event. The MCU has just to launch the timer decrementation between two NMI interrupts to calculate how much one must load the TCR register to count down 20 ms.

Of course, in normal operation, the timer can be used for other tasks than counting the mains period. The period measurement will then be based on the rest of time from the last timer utilization and the next NMI interrupt. This measured time is saved as DELTAT (cf. Figure 2) by the software. The 20 ms will then equal the DELTAT, plus the sum of times T1 to T3, plus the time lost due to calculator operations between each timer stop and launch (cf. paragraph 4.3).

N.B.: such a method is only valid when the mains frequency is known in advance; i.e. for a board dedicated to one range of AC mains voltage. In our case, the software and hardware are dedicated to 220/240 V 50 Hz applications.

APPLICATION NOTE

Fig. 2: Timing definition

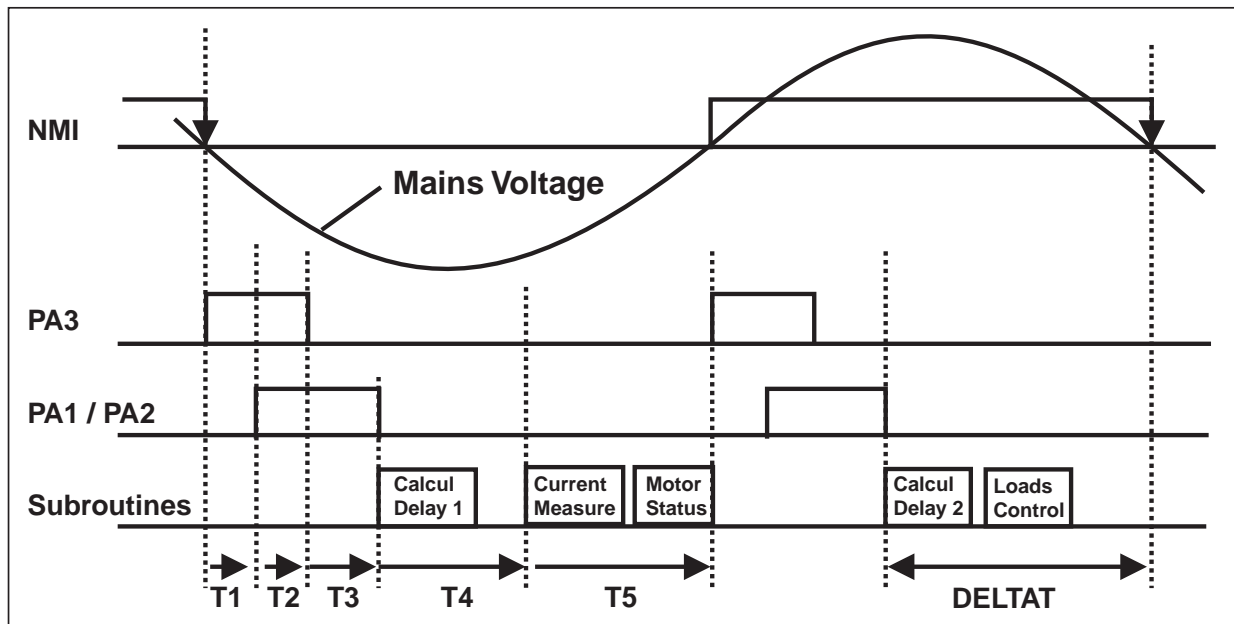

3.2 Subroutines execution time checking

In order not to miss the timer interrupt events, the CPU must be completely free and ready to check the timer interrupt flag. This means that all subroutines must be completed before the expected end of the timer decrementation.

Figure 2 shows that the subroutines are placed at different moments, depending on their length. For example, the longest CPU action is when the MCU calculates the T1 to T5 delays. This action can last up to more than 7.2 ms for a 4MHz MCU clock frequency. Then, there is not enough time available between two timer interrupts to calculate these five values. This is the reason why the delay calculation subroutine has been split into two parts (Calcul-Delay_1 and Calcul-Delay_2). These two parts are respectively placed during T4 and DELTAT decounts

Table 3 gives the maximum duration of each subroutine (for a 4 MHz clock frequency, and the for the longest software loops).

Table 3: Subroutines maximum durations

SUBROUTINE NAME	MAXIMUM TIME
Loads_Control	0.93 ms
Motor_Status	0.26 ms
Current_Measure	0.92 ms
Calcul_Delay_1	1.75 ms
Calcul_Delay_2	5.49 ms

Table 4 gives the code execution maximum times for all the instructions written in the software, before each subroutine ("code execution time" column). Then, according to the implemented durations, the time, still available for the CPU, is given with a 0.2 ms safety margin.

Table 4: CPU available time

Name	Duration (ms)	Code execution time (ms)	Subroutines time sum (ms)	Available time (ms)
T1	0.45	0.25	0	0
T2	1.05	0.13	0	0.72
T3	1.75	0.13	0	1.42
T4	3.95	0.85 (T50Hz average)	1.75	1.15
T5	2.80	0.09	0.26 + 0.92	1.33
DELTAT	6.75	0.08	5.49 + 0.93	0
TOTAL				4.62

3.3 Start-up and Smart Reset

At each RESET interrupt, the program first checks if the data stored in the RAM are as scheduled or not. Indeed, a RESET can occur without the supply voltage having fallen below V_{RM} (Data retention parameter: 0.7 V). In this case, a whole start-up is not necessary, and the program can keep working with the previous RAM data. This is helpful in order to avoid missing loads control when a RESET occurs, due to an EMI problem for example.

If the checked RAM registers are not as expected, then a complete initialization procedure is launched (cf. annex 2). This routine, among other things, configures the A and B ports, waits 100 ms before go on (waiting for the stabilization of the supply), and measures the mains period for the first time.

If the RAM area is adequate, then a "Smart Reset" can be performed. Only the registers which are used to store internal sub-routines variables are cleared. Only the main registers keep their previous values (motor status, etc.).

It is important to note that this start-up procedure can miss firing some loads during one mains cycle. This is why, if the motor was at start-up state before a "Smart Reset", it is better to stop the motor. This avoids switching both the T_r and T_s devices ON together when the split-phase capacitor can be charged (refer to AN1354). This is done by simply setting to high level the overcurrent detection flag.

4. GATE CURRENT PULSES

4.1 General description

The gate current pulses are generated during the main program (refer to annex 1 and also to Figure 2). The Port A pins are set or reset depending on the information defined by the sub-routines described in paragraph 5.

Annex 1 gives the flowchart of the main program. The ZVC events are sensed thanks to bit 0 of the FLAG register, which is only set during the NMI interrupt. The end of timer decrements are also sensed by bit 1 of the FLAG register, which is set during timer interrupt.

First, as soon as the ZVC is detected, the T1 decrementation is launched and the light-bulb is switched on, if requested, by pulling PA3 down to V_{SS} . After the timer interrupt, PA2 and PA3 are set, or not, depending on the process status. After T2 decrementation, PA3 is set and a new decrementation is launched (T3) to wait to turn-off both T_r and T_s .

After this pulse generation, the timer counts down T4 to synchronize the current measure to the moment at which it reaches its peak value. After the "Current_Measure" sub-routine, T5 is decremented in order to reach the beginning of the next half cycle. Gate current pulses are then generated as in the previous cycle.

APPLICATION NOTE

4.2 How to change the pulse duration ?

All the pulse durations are based on a one half-cycle time reference basis. Indeed, in order to count the period time, the timer is launched after the last current pulse, when V_{LN} is positive. DELTAT will then always represent a time shorter than 10 ms. To be sure that the timer overflow will never occur before the next NMI interrupt, we must ensure that the time to decrement 256 will be always higher than 10 ms.

This condition can be reached with a 32 prescaler ratio. With such a value, even with the maximum allowed MCU clock frequency, the overflow will happen in 12.28 ms.

$T50Hz = DELTAT + T1 + T2 + T3$, then represents the value to load in the TSCR register to achieve a 10 ms overflow period.

To define a "n" ms duration, consider the following relation:

$$\left. \begin{array}{l} 10ms \rightarrow T50Hz \\ n_{(ms)} \rightarrow Tx \end{array} \right\} Tx = \frac{T50Hz \times n_{(ms)}}{10}$$

So, Tx must be loaded in the TSCR to have a timer interrupt after "n" ms. However, as a division by ten is not easy to implement, and in order to increase the register accuracy, it is better to use variables in the range of 256. The variable "Dx" is used and defined as explained below:

$$Dx = \frac{n \times 256}{10}$$

When, Tx can be calculated as follows:

$$Tx = \frac{T50Hz \times Dx}{256}$$

Dividing by 256 is thus easily achieved simply by considering the Most Significant Byte of the multiplication result of T50Hz and Dx. The Dx variables are defined in the Constants list at the beginning of the software. To implement new pulse timings, only the values in this list have to be changed.

For 60Hz applications, the "10ms" used in the calculation should be replaced by 8.33.

4.3 Influence of the code time

In fact, the timer is not launched exactly when it has to be. This is due to the time required by the MCU to perform some instructions between the last interrupt and the effective decrementation beginning.

For example, before the launch of the first T1 decrementation, the program must run the NMI interrupt, save the DELTAT result, write PORT A and the start the timer. These 47 instructions all in all last 200 μ s for a 4 MHz MCU clock frequency. Then, to ensure that the gate current will be applied on the Tr and Ts devices at the right time, it is better to cut off this delay from T1.

Furthermore, this delay will vary depending on the MCU clock frequency (f_{cpu}), which will vary according to the junction temperature and the supply voltage level. So, a method is required to remove the code delay whatever f_{cpu} is.

First, we know that the oscillator frequency is divided by 13 to drive the CPU core. Therefore, "N" CPU cycles last $13 \times N / f_{cpu}$ seconds.

Secondly, the CPU oscillator frequency is divided by 12 to drive the Timer, and then divided by the division factor programmed in the TSCR register. In our case, the division factor is 32 during the main program loop. Therefore, one unit timer counter equals $12 \times 32 / f_{cpu}$. Based on the previous formula, we can easily convert N cycles code execution time to the timer counter value (Tcode), as shown below.

$$Tcode = \frac{N \times 13}{f_{cpu}} \times \frac{f_{cpu}}{12 \times 32} = N \times \frac{13}{384}$$

For example, the length of the code time for 47 cycles approximately equals one unit of the timer counter. Then, one must be subtracted from T1 in order to rectify the gate current pulse delay from the code execution delay.

For T2 and T3, it does not matter if the code execution delay is removed or not. Indeed, it is not a problem that the gate current pulses last longer.

For T4, it is important to begin the current measure at the right time. The 98 cycles must then be subtracted from T4. This leads to subtract 3 from the TSCR register value.

When the half-cycle duration is calculated, the code execution time must also be added to T50Hz. As 110 cycles are performed, 4 must be added to the T50Hz value.

4.4 Timing example

Table 5 gives the values which must be loaded into the TSCR register to implement a 1.5 ms pulse (to trigger the light) and a 0.45 ms delayed pulse of 2.8 ms length (to trigger the both windings of the motor). These are the values programmed by default in the THERM01EVAL board microcontroller.

Table 5: TSCR values to implement the required pulses

NAME	DELAY (ms)	TSCR value (decimal)
T1	0.45 (- code delay)	12 - 1
T2	1.05	27
T3	1.75	45
T4	3.95 (- code delay)	101 - 3

5. SUB-ROUTINES

5.1 Loads Control

This sub-routine defines which load has to be turned on (refer annex 3). The light bulb is then controlled depending on the door-switch information. It is the sensed temperature, the order set by the external potentiometer and the Hysteresis law, described in Figure 3, that instructs the motor to be ON.

Order 1, the upper limit, equals the temperature order set by an external potentiometer plus a threshold value (which can be changed, refer to "THRES" in the constants list). Order 2 equals the same order minus this threshold.

Fig. 3: Temperature Hysteresis control

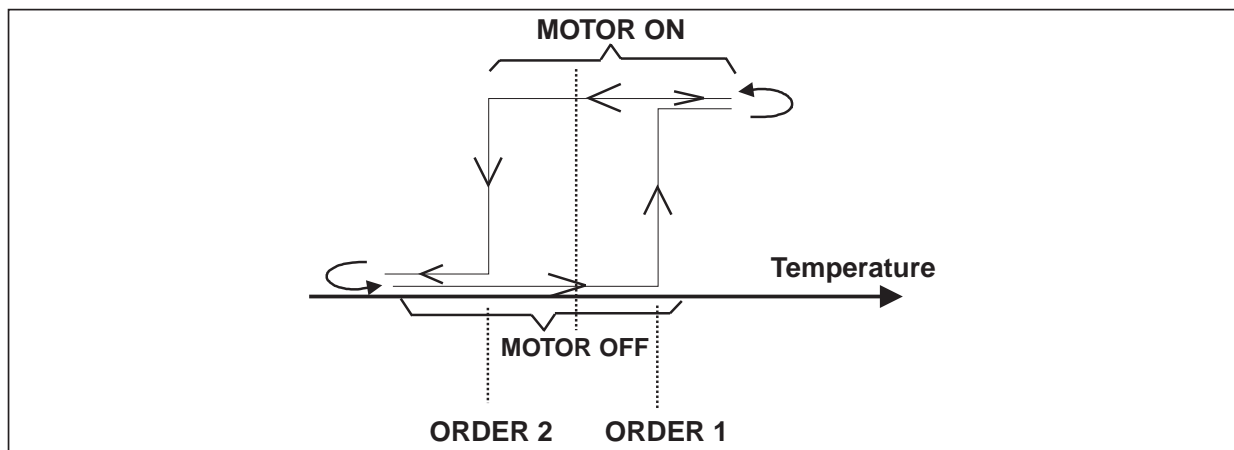

APPLICATION NOTE

This sub-routine also defines if the motor must be started up. If the temperature becomes higher than ORDER 1, the compressor should be started. But, care must be taken not to start the motor if it is already ON. Otherwise, Ts could be switched on when Tr is already ON, resulting in a capacitor discharge through the two devices.

Note that each evaporator temperature and potentiometer voltage measurements are refreshed every 256 cycles (by the average value of the previous 256 cycles). This means that the temperature control is activated every 5 seconds.

5.2 Motor Status

This sub-routine defines which ACST must be triggered depending on the motor state and the order asked by the "LOADS_CONTROL" routine. This flowchart is shown on annex 4.

When the motor is required to be ON, both Tr and Ts are switched on 500 ms. After that, only Tr is fired, if the motor must still be ON. In this case, the MOTOR_STATUS routine claims that the motor is in a transient state again for 500 ms. This state is used by the "CURRENT_MEASURE" sub-routine. Indeed, the current must not be measured during the first one second of operation, during which the current is high. On the other hand, if the current remains high after this one second, that means that an abnormal condition has occurred (stall rotor for example) and it is better to stop the motor.

5.3 Current Measure

The current measure is only performed when the motor should be ON, and if it is not at start-up transient state. At each overcurrent detection, the motor is stopped, a LED is switched on during 5 s, and, of course, the current measure is no longer performed.

The overcurrent detection is, in fact, based on an average of four measures. This is done to reduce EMI noise. The over-current therefore always acts with at least an 80 ms delay, because only one measure by cycle is done.

The measured value is compared to the "VLIMIT" constant. A 242 value equals a voltage of 5.22 V at the input of the Analog to Digital Converter (for a 5.5 V supply). As the measure is achieved thanks to a 50 mOhm shunt, referenced to the Vdd, this value is similar to a 5.6 A current. Such a current means that the rotor is stalled because, in steady state, a 100-300 W compressor always sinks a current lower than 3 A.

6. CONCLUSION

This paper has presented how a software for ST6200C MCUs has been developed for thermostat applications. The main goals of this software are:

- Low-cost: no external resonator is used even if good accuracy for time control is required. This is achieved thanks to a mains period based calculation method. No external RESET circuit is needed thanks the MCU LVD option.
- Low-consumption: all ACS and ACST devices are triggered by pulsed gate currents in order to reduce the average current consumption.
- Noise immunity: the noise immunity has been increased by several software techniques (smart reset, ADC results averaging). The Hardware Watch-Dog option must also be activated and unused program memory space can be filled as described in the AN435 Application Note.

This paper will help users to adapt the software to their own requirements. The following data in particular must be checked:

- Peak current measure moment (T5 register)
- Gate current pulses delay & duration
- Maximum peak-current value to detect an over-current (VLIMIT constant)
- Temperature control Hysteresis threshold.

ANNEX 1: Main Program Flowchart

Fig. 4: Main program flowchart

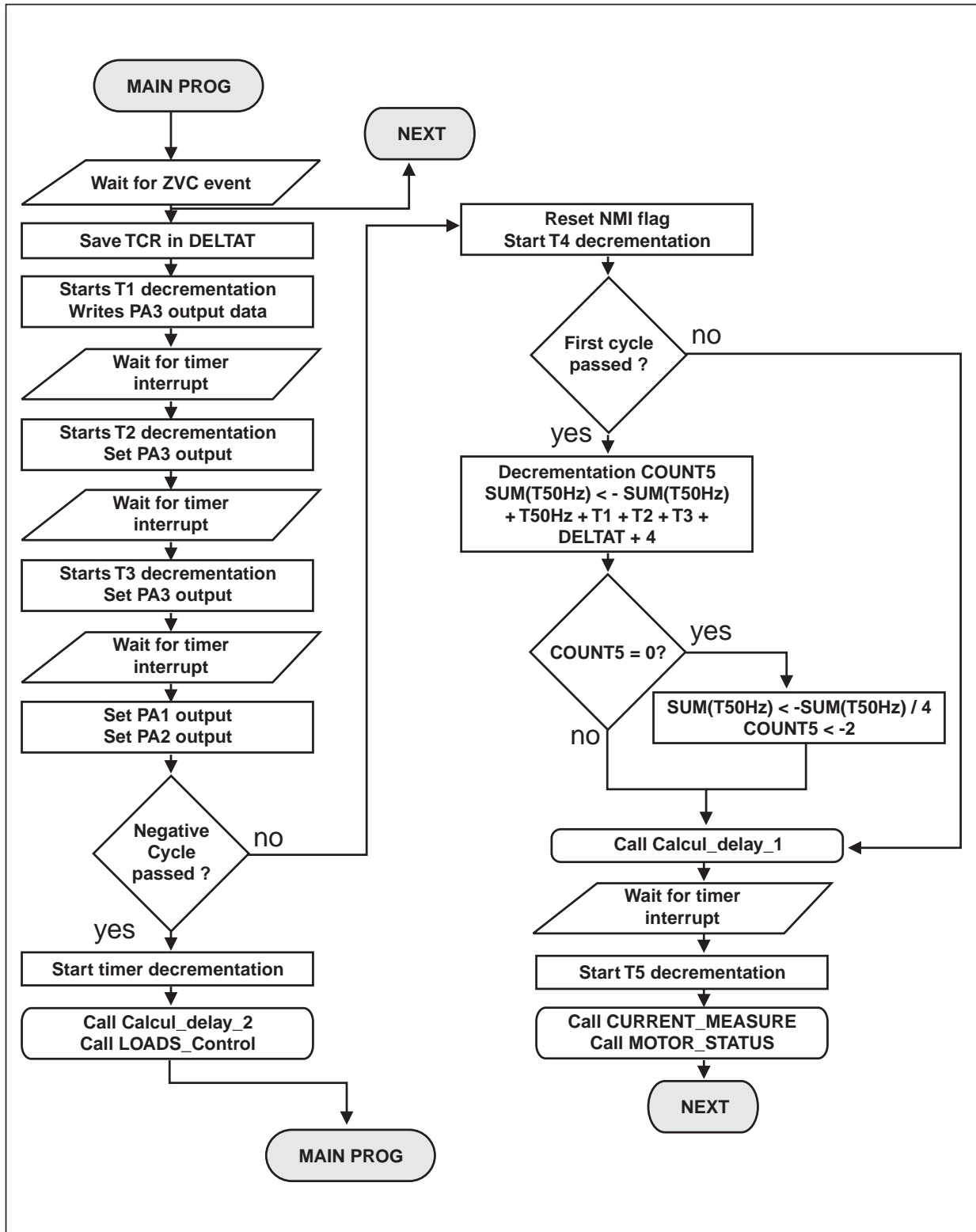

APPLICATION NOTE

ANNEX 2: Start-up procedure

Fig. 5: Start-up procedure

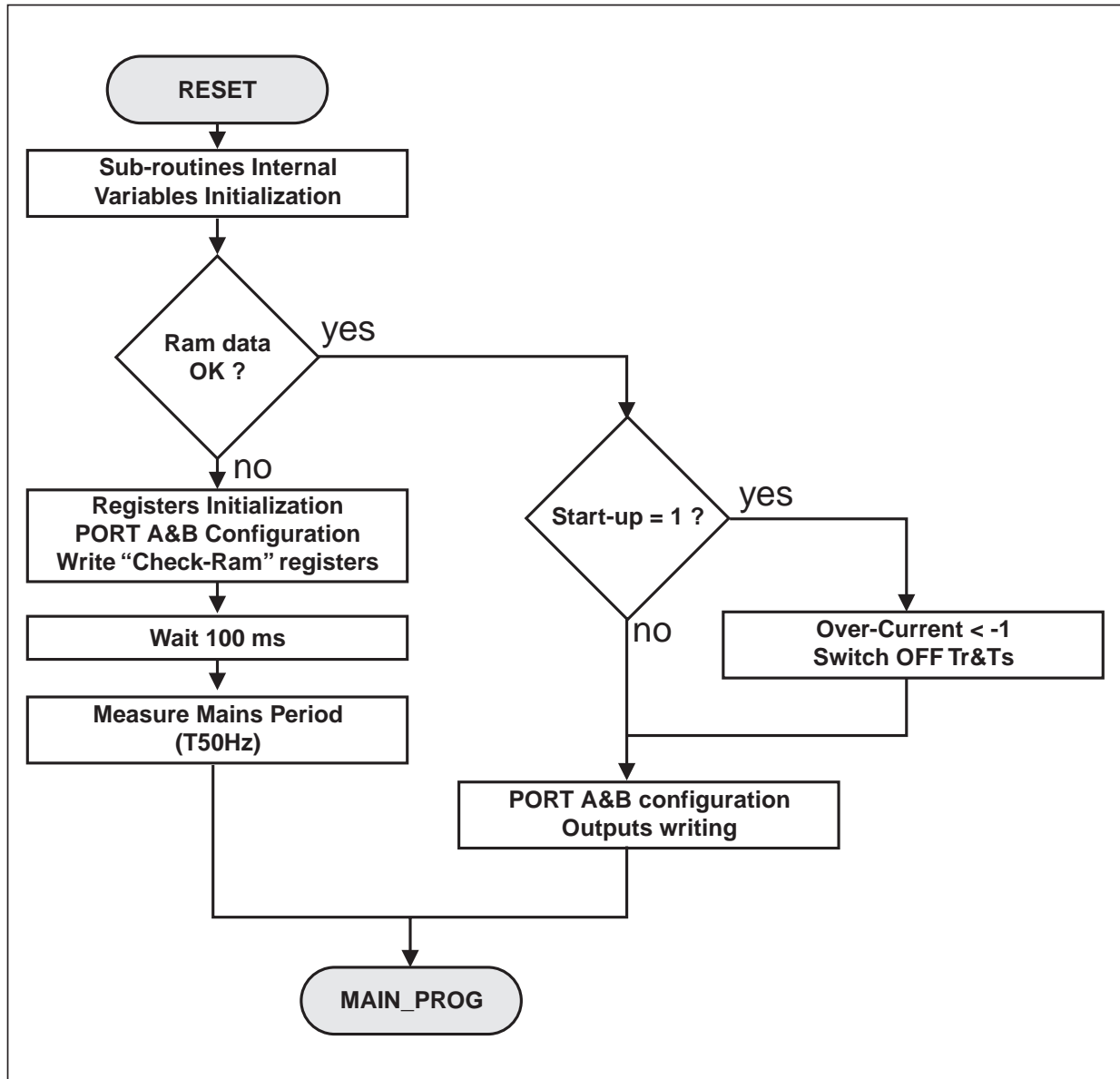

ANNEX 3: Loads_Control Sub-Routine

Fig. 6: Loads_Control flowchart

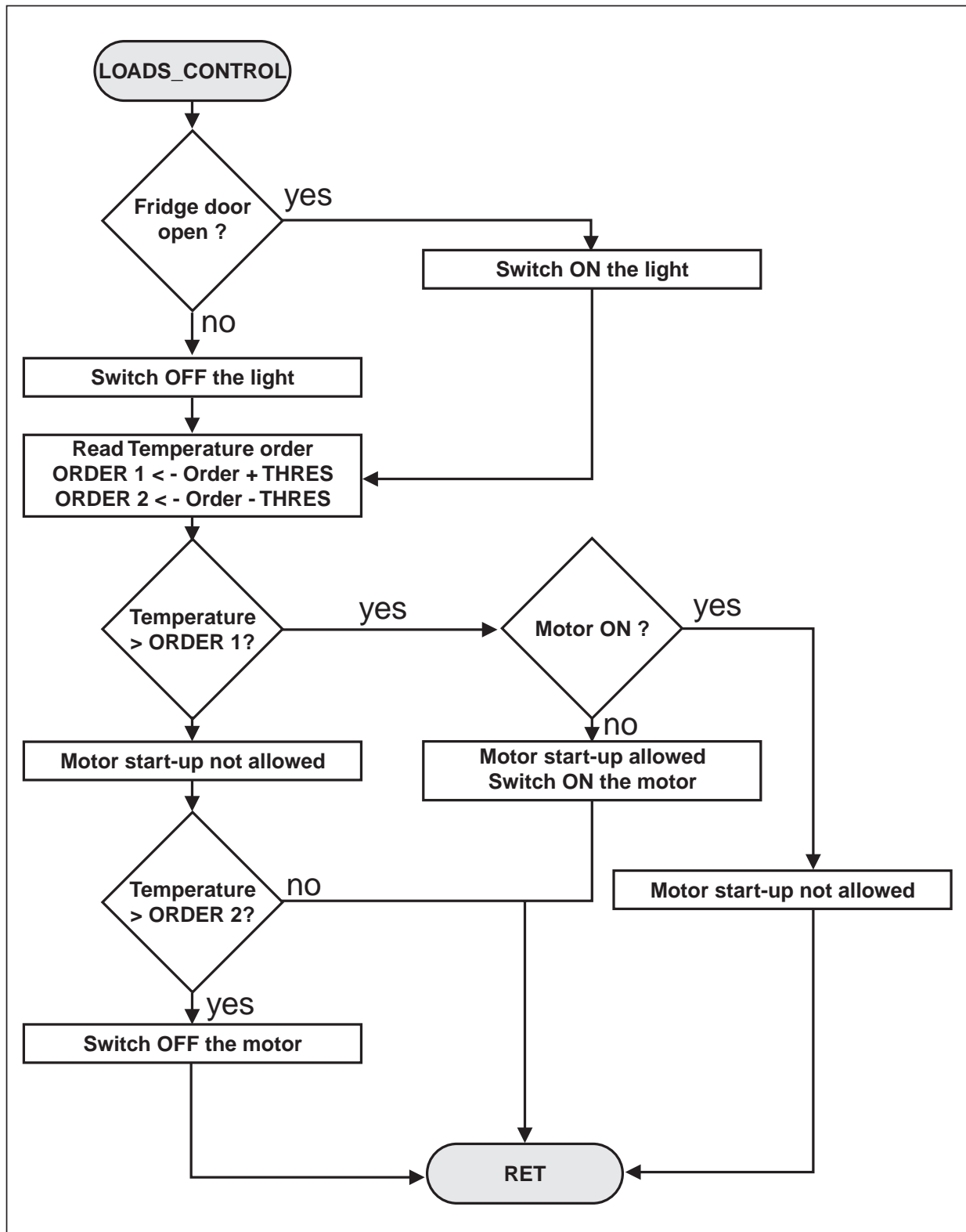

APPLICATION NOTE

ANNEX 4: Motor_Status procedure

Fig. 7: Motor_Status flowchart

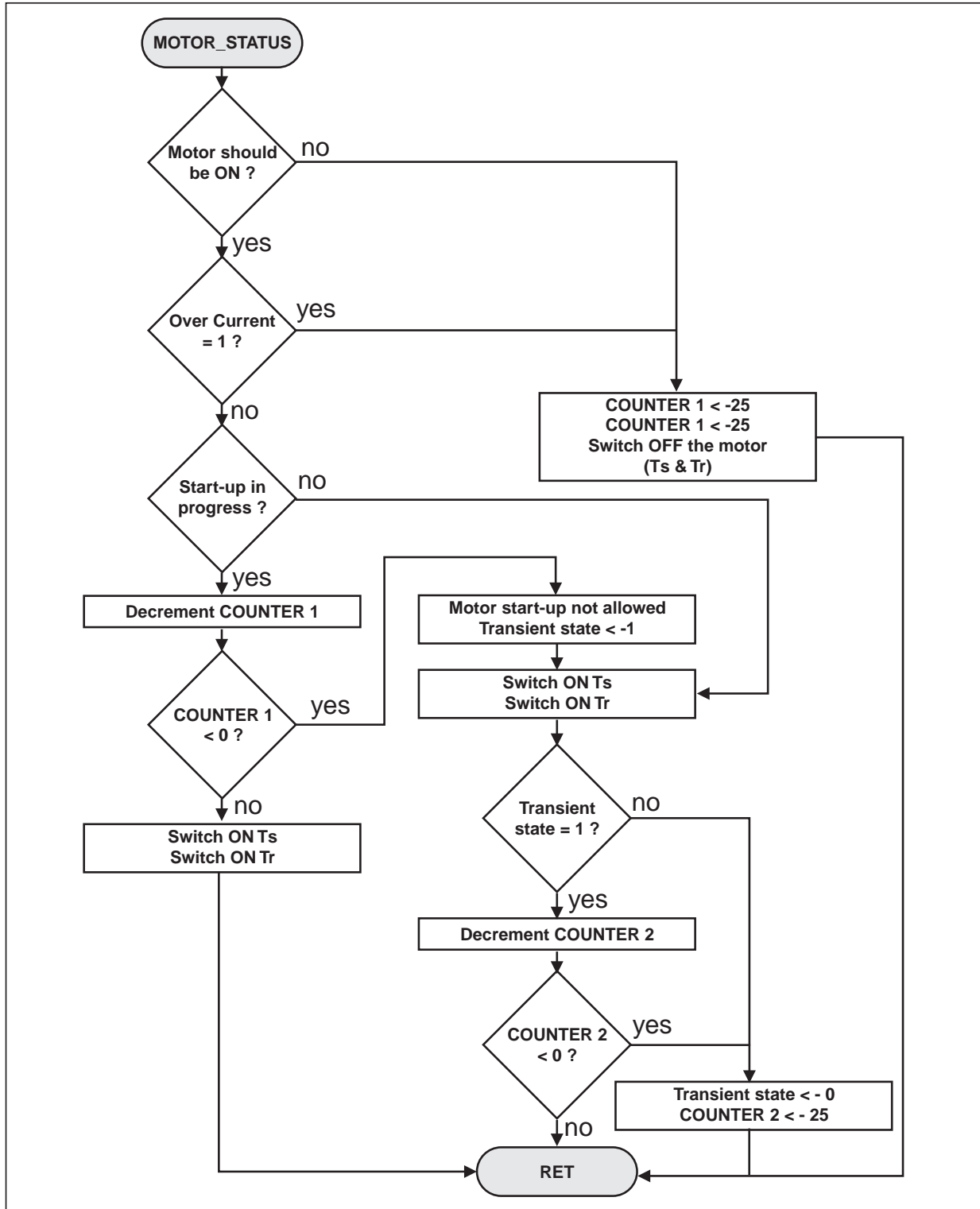

ANNEX 5: Current_Measure procedure

Fig. 8: Current_Measure flowchart

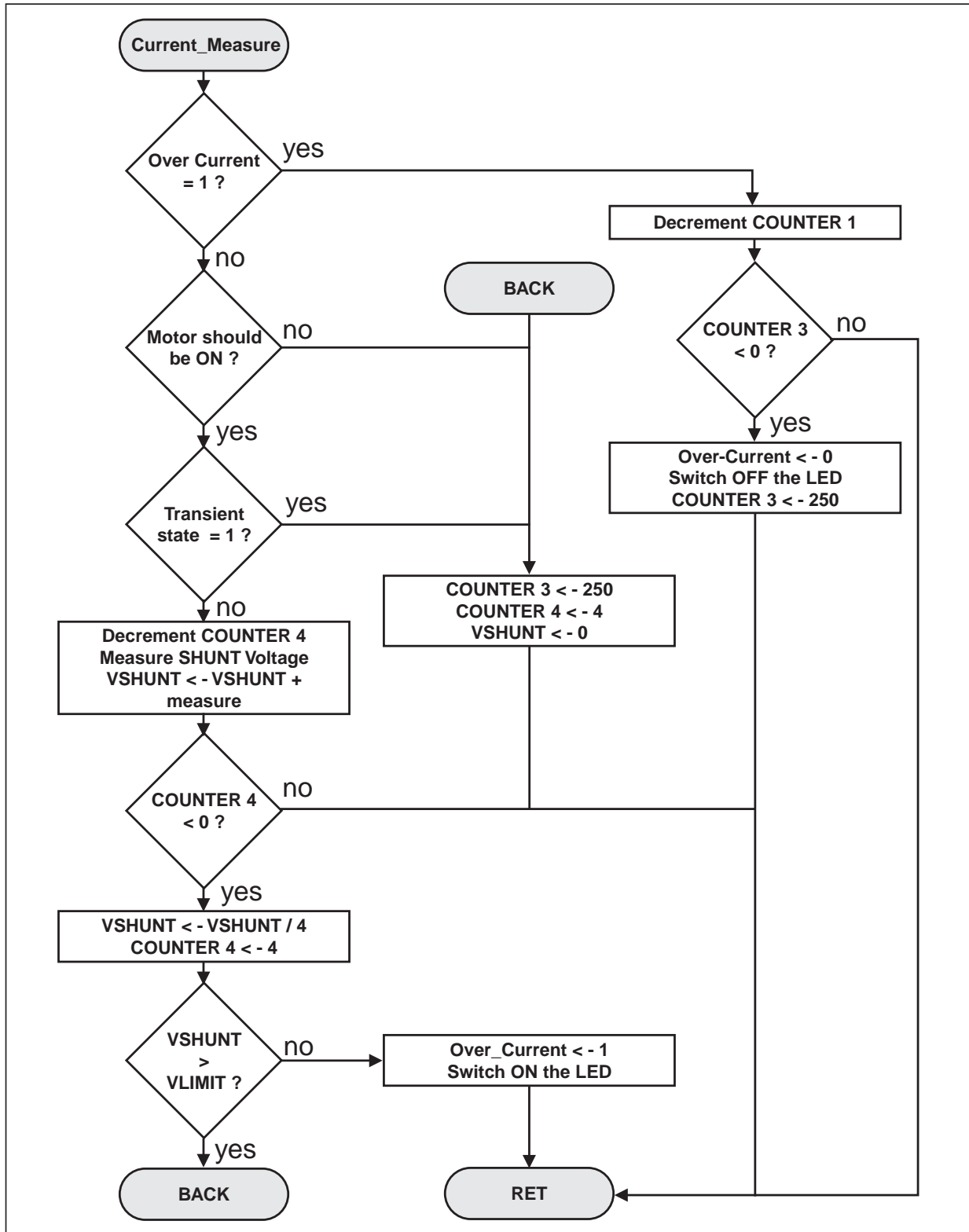

APPLICATION NOTE

Information furnished is believed to be accurate and reliable. However, STMicroelectronics assumes no responsibility for the consequences of use of such information nor for any infringement of patents or other rights of third parties which may result from its use. No license is granted by implication or otherwise under any patent or patent rights of STMicroelectronics. Specifications mentioned in this publication are subject to change without notice. This publication supersedes and replaces all information previously supplied. STMicroelectronics products are not authorized for use as critical components in life support devices or systems without express written approval of STMicroelectronics.

The ST logo is a registered trademark of STMicroelectronics

© 2001 STMicroelectronics - Printed in Italy - All rights reserved.

STMicroelectronics GROUP OF COMPANIES

Australia - Brazil - China - Finland - France - Germany - Hong Kong - India - Italy - Japan - Malaysia
Malta - Morocco - Singapore - Spain - Sweden - Switzerland - United Kingdom - U.S.A.

<http://www.st.com>



LittleDiode supplies new, hard to find or obsolete electronic components and semiconductors all over the world.

With over two million different components listed you are sure to find the part you need.

Feel free to visit us today at our online store:

LittleDiode.com

Looking forward to providing you with the best possible service.