

Programmable Tee Networks

Chuck Wojslaw

The objective of this application note is to (1) illustrate the idea of using digitally controlled potentiometers to form tee networks and (2) provide the design engineer with reference designs for using tee networks and their derivatives as building blocks in analog circuits and systems.

Basic Ideas

A tee network is a two-port network whose configuration, Figure 1, is in the form of the letter tee. The components used to implement the tee network can themselves be another network but they are usually single resistors and capacitors. Tee networks are used as building blocks in analog circuits including amplifiers, filters, oscillators, and converters. The three-terminal potentiometer, along with passive parts, eases the implementation of the tee network. If a digitally-controlled potentiometer is used, Figure 2, the analog section will provide variability to the circuit and the digital controls will provide programmability. The basic tee network can be expanded to include the bridged tee, twin tee, and π networks which are shown in Figure 3. The movement of the wiper of the potentiometer introduces a new degree of freedom k in the tee network where k is a number that varies from 0 to 1 and reflects the proportionate position of the wiper from one end of the pot (0) to the other end of the pot (1). The resistances from the wiper to the low terminal and the wiper to the high terminal are modeled as kR and $(1-k)R$ and are shown in Figure 4. The resistance R is the same as the potentiometer's end to end resistance called R_{TOTAL} . In analyzing many analog circuits, the tee network is

treated as a two port and its input-output relationship is described by the short-circuit admittance coefficients Y_{21} and Y_{12} .

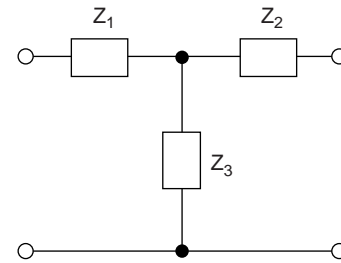

Figure 1. "T" Network

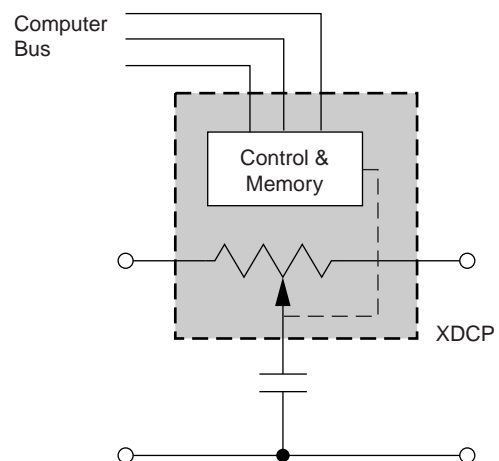

Figure 2. Programmable Tee Network

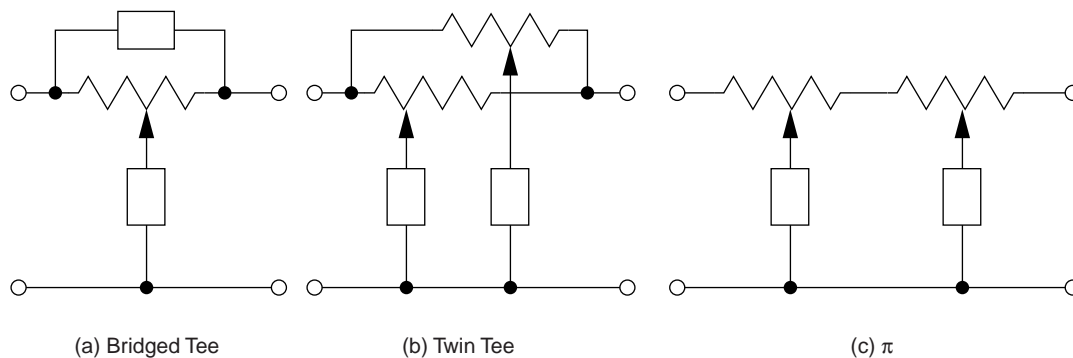

Figure 3. Tee Network Parameters

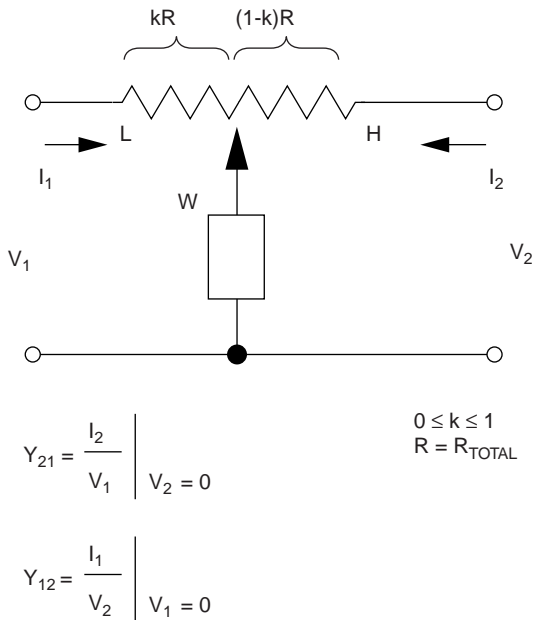

Figure 4. Tee Network Parameters

The use of digitally-controlled potentiometers in programmable tee networks will be illustrated in several representative circuits including amplifiers, filters, and converters.

AMPLIFIERS: *Digitally Controlled Potentiometer Sets Cutoff Frequency*

FILTERS: *Programmable Tee Network Controls Sallen and Key Filter*
Programmable Tee Networks Control IGSF Filter

CONVERTORS: *I to V Convertor*

These basic analog circuits are used as universal building blocks in the design of analog systems and they also serve as models for more specialized analog functions. The following collection of independent articles and circuits are examples of using programmable tee networks in analog circuits. All of them have been breadboarded and tested.

Digitally Controlled Potentiometer Sets Cutoff Frequency

The traditional way of controlling the upper cutoff frequency in the basic inverting amplifier circuit of Figure 5 is to parallel R_2 with a capacitor C. The cutoff frequency is controlled with the capacitor C and the magnitude of the circuit gain is independently established by R_2 and R_1 ($=R_2/R_1$). If we need a variable cutoff frequency, we use a variable capacitor.

This approach has two major problems (1) the circuit does not lend itself to computer control and (2) availability of variable capacitors especially in the nF region.

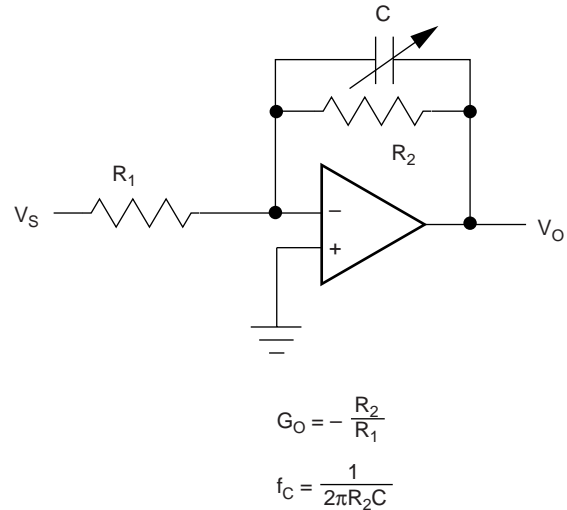

Figure 5. Traditional Inverting Amplifier

The circuit in Figure 6 is an inverting amplifier that uses the digitally-controlled potentiometer and a fixed capacitor as an input 'tee' network. The magnitude of the gain for this inverting circuit is the same as the traditional circuit R_2/R_1 but the cutoff frequency is established by R_1 , capacitor C, and the location of the wiper along the resistor array of the potentiometer. Since the wiper of the digitally-controlled potentiometer is digitally or computer controlled, the upper cutoff frequency can then be programmed.

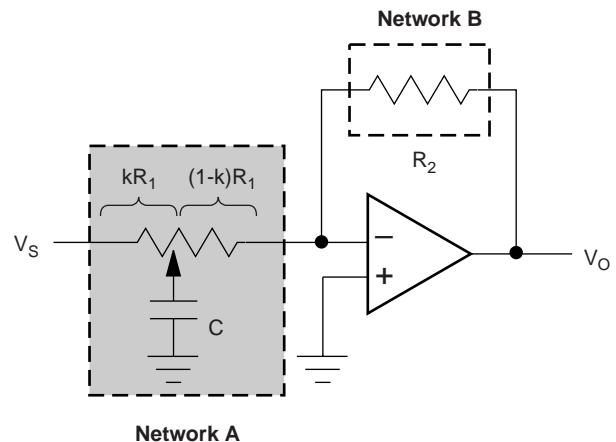

Figure 6. Amplifier with Input Tee Network

The circuit gain (as a function of frequency) can be determined using several analysis approaches. One approach is to use Y or admittance parameters. If

network A and network B are treated as two-ports, the ratio of the short-circuit admittance coefficient Y_{21} for the input port to Y_{12} for the feedback port will produce the gain expression (Figure 6).

$$\frac{V_o}{V_s} = \frac{Y_{21A}}{Y_{12B}} = \frac{(R_2/R_1)(1/R_1 Ck(1-k))}{j\omega + (1/R_1 Ck(1-k))}$$

k is a number that varies from 0 to 1 and reflects the proportionate position of the wiper from one end (0) of the potentiometer to the other end (1).

The circuit's gain expression is of the form

$$\frac{V_o}{V_s} = \frac{A_o \omega_c}{j\omega + \omega_c}$$

which is that of an amplifier or low pass filter with a gain $G = -R_2/R_1$ and a cutoff frequency

$$f_c = \frac{1}{2\pi R_1 Ck(1-k)}$$

As the wiper is programmed from one end of the potentiometer to the other, k varies from 0 to midscale (1/2) to 1, and the cutoff frequency varies from infinite Hertz to a minimum frequency and back to infinite Hertz. The minimum frequency is

$$f_c(\text{min}) = \frac{4}{(2\pi)R_1 C}$$

For the Xicor digitally-controlled potentiometer (XDCP), k will vary from 0 to 1 with a resolution determined by the number of taps or programmable wiper positions and R_1 represents the R_{TOTAL} of the potentiometer. The number of taps varies from 32 to 256 and R_{TOTAL} varies from $1k\Omega$ to $1M\Omega$ depending on the particular potentiometer. A wiper or cutoff frequency setting can be stored in the XDCP's nonvolatile memory permitting the circuit's cutoff frequency to return to a predetermined value on power-up.

For the circuit values shown in Figure 7, the gain is -4.7 and the cutoff frequency varies from 6.4kHz to the frequency limited by the LT1007. The circuit uses Xicor's X9C103 which is a $10k\Omega$ potentiometer with 100

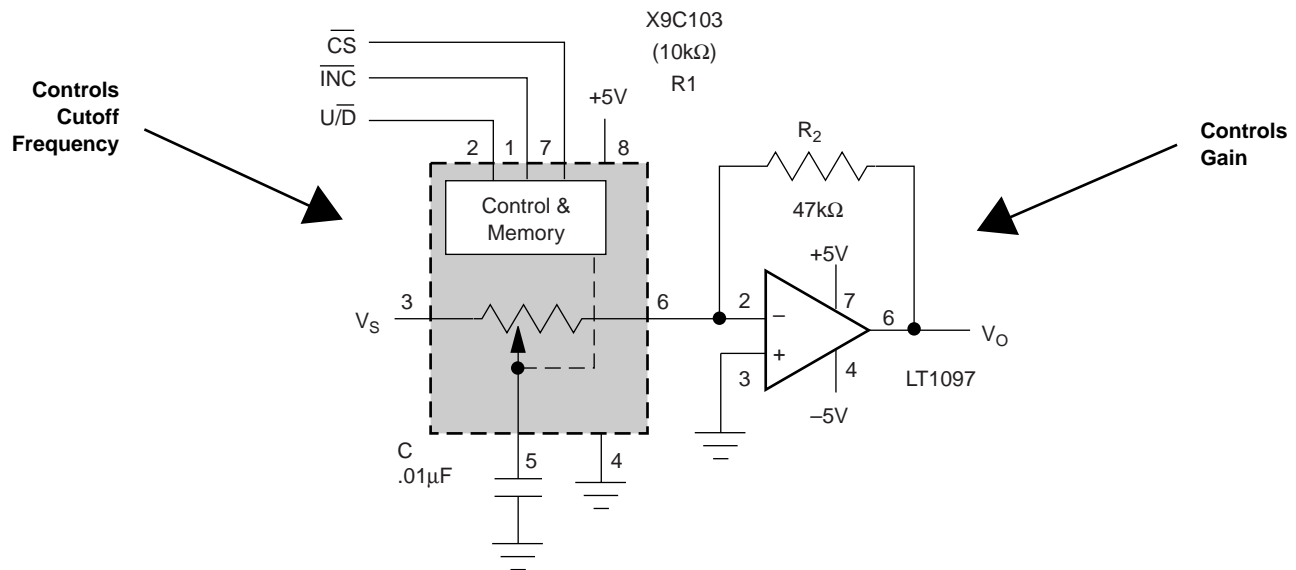

$$G = \frac{V_o}{V_s} = \frac{A_o \omega_c}{j\omega + \omega_c} = \frac{-(R_2/R_1) (1/R_1 Ck(1-k))}{j\omega + (1/R_1 Ck(1-k))}$$

$$A_o = -R_2/R_1 = -4.7$$

$$f_c = \frac{\omega_c}{2\pi} = \frac{1}{2\pi R_1 Ck(1-k)}$$

$$f_c(\text{min}) = \frac{4}{2\pi R_1 C} = 6.4 \text{ kHz}$$

Figure 7. Computer Controlled Amplifier

taps and a three-wire interface. Other XDCPs are available with SPI and I²C interfaces. The circuit can be used in audio, control, and signal processing applications. (*published in EDN, June 10, 1999*)

Programmable Tee Network Controls Sallen and Key Filter

The circuit in Figure 8 is a common way of implementing a second order, low pass filter. This Sallen and Key scheme provides a passband gain A₀ of one and R₁, R₂, C₁, and C₂ establish the characteristic frequency ω₀ and figure of merit Q. The circuit in Figure

9 replaces R₁ and R₂ with a digitally-controlled potentiometer and along with C₁ is configured as a tee network. The location of the wiper changes the relative values of R₁ and R₂ and thus introduces another degree of freedom in the filter design. Since the wiper of the Xicor digitally-controlled potentiometer (XDCP) is computer controlled, this new degree of freedom k can be programmed. k is a number that varies from 0 to 1 and reflects the proportionate position of the wiper from one end (0) of the potentiometer to the other end (1). The resolution of k is determined by the number of taps or programmable wiper positions and R represents

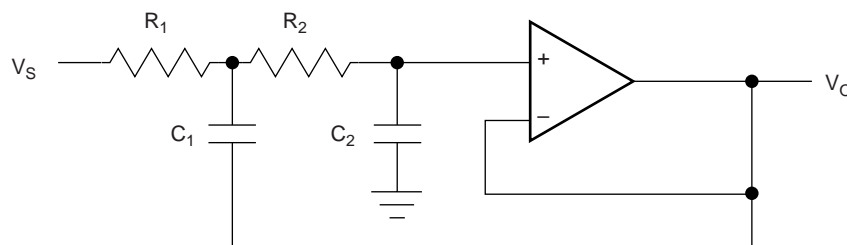

$$T(s) = \frac{V_O}{V_S} = \frac{1}{R_1 R_2 C_1 C_2} \frac{1}{s^2 + \left(\frac{1}{R_2 C_1} + \frac{1}{R_2 C_2} + \frac{1}{R_1 C_1} \right) s + \frac{1}{R_1 R_2 C_1 C_2}}$$

$$= \frac{G_0 \omega_0^2}{s^2 + (\omega_0/Q)s + \omega_0^2}$$

Figure 8. Model of Sallen and Key Filter

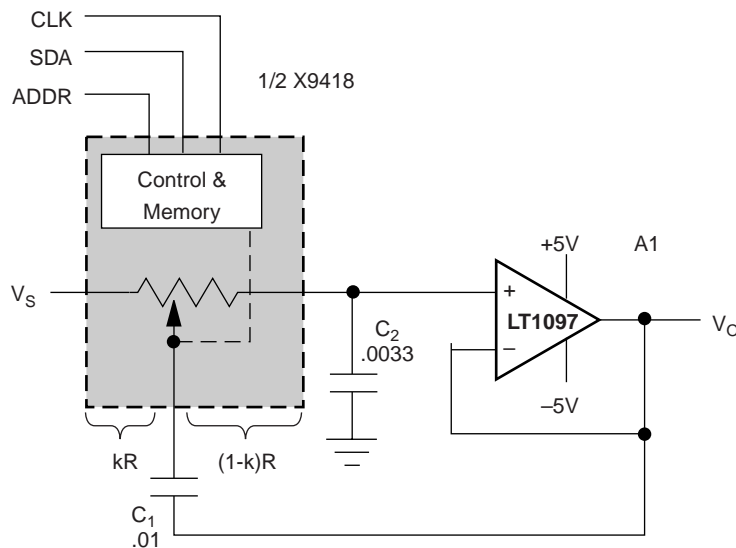

$$\frac{V_O}{V_S} = \frac{1}{k(1-k)R^2 C_1 C_2} \frac{1}{s^2 + s \left[\frac{1}{k(1-k)RC_1} \right] + \frac{1}{k(1-k)R^2 C_1 C_2}}$$

A₀ = G₀ = -1

$$\omega_0 = \sqrt{\frac{1}{k(1-k)R^2 C_1 C_2}} \quad Q = \sqrt{\frac{k(1-k)C_1}{C_2}}$$

MFM (Marginally Flat Magnitude)
 k = 13/63
 Q = .704
 f₀ = f_c = 6.85kHz

Figure 9. Sallen and Key Filter with the Tee Network

R_{TOTAL} or the end to end resistance of the potentiometer. The gain expression or transfer function for this circuit is

$$\frac{V_o}{V_s} = \frac{1}{s^2 + s[1/k(1-k)RC_1] + 1/k(1-k)R^2C_1C_2}$$

$$\frac{V_o}{V_s} = \frac{A_o\omega_o^2}{s^2 + s(\omega_o/Q) + \omega_o^2}$$

This is the classic expression for a second order low pass filter where

$$A_o = 1 = \text{Pass Band Gain}$$

$$\omega_o = \sqrt{\frac{1}{k(1-k)R^2C_1C_2}}$$

and

$$Q = \sqrt{\frac{k(1-k)C_1}{C_2}}$$

The accuracy of filter parameters is dependent on the component sensitivities and the tolerance of the component values. Precise values of the parameters are difficult to achieve because precise values of capacitance are limited and expensive. This limitation of performance can be overcome using the programmable tee network. The characteristic frequency ω_o or figure of merit Q can be precisely controlled depending on the critical need of the application.

For the values shown in Figure 9, the filter can be programmed for a theoretical maximally flat magnitude (MFM or Butterworth) response when $k=13/63$. For this value of k , $Q=.704$ and $f_o = 6.85\text{kHz}$. When the programmable tee network is at its limits ($k=0$ or $k=1$), the circuit reduces to a first order low pass filter whose cutoff frequency $f_c=1/2\pi RC_2$. A second potentiometer can be used to control the noninverting, closed-loop gain of A_1 and establish the passband gain A_o of the filter.

The electronic potentiometer adds variability to the filter circuit and its digital controls, though its computer-controlled serial bus, provide programmability. The X9418 has a 2-wire (I²C like) serial bus. An automated

closed-loop calibration procedure to program the filter saves test time and provides enhanced performance and security. *(to be published in Electronics World [UK])*

Programmable Tee Networks Control IGSF Filter

The circuit in Figure 10 is a second order, low pass filter model that falls in the Infinite Gain, Single Feedback (IGSF) class. IGSF type filters are characterized by two-port input and feedback networks. Common two-ports used in filters are the tee network and its bridged tee and twin tee derivatives. If a digitally controlled potentiometer and a capacitor are used to implement the tee network, variability and programmability are added to the circuit.

The circuit in Figure 11 is basically an inverting amplifier where the input circuit A is a tee network and the feedback circuit B is a bridged tee network. The movement of the wiper of the potentiometer introduces a new degree of freedom k in the filter design where k is a number that varies from 0 to 1 and reflects the proportionate position of the wiper from one end of the pot (0) to the other end of the pot (1). The gain expression or transfer function of the filter is found by finding the ratio of the short-circuit admittance coefficients of the input and feedback networks. For this circuit,

$$\frac{V_o}{V_s} = -\frac{Y_{21A}}{Y_{12B}} = -\frac{1/kR(1-k)RC_1C_2}{s^2 + s[(1/k(1-k)RC_1] + 1/k(1-k)R^2C_1C_2}$$

This is the classic expression for a second order filter given by

$$\frac{V_o}{V_s} = \frac{A_o\omega_o^2}{s^2 + s(\omega_o/Q) + \omega_o^2}$$

where A_o , ω_o , and Q represent the passband gain, characteristic frequency, and figure of merit respectively.

From the gain expression,

$$A_o = 1,$$

$$\omega_o = \sqrt{\frac{1}{k(1-k)R^2C_1C_2}}$$

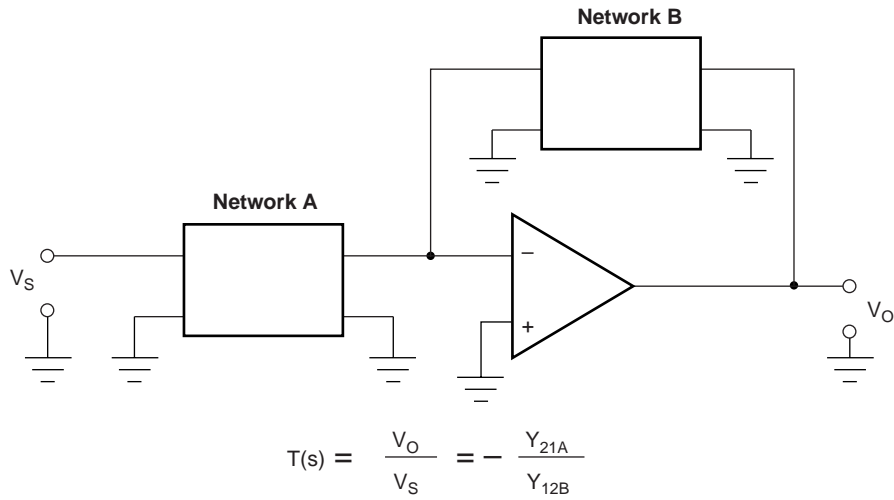
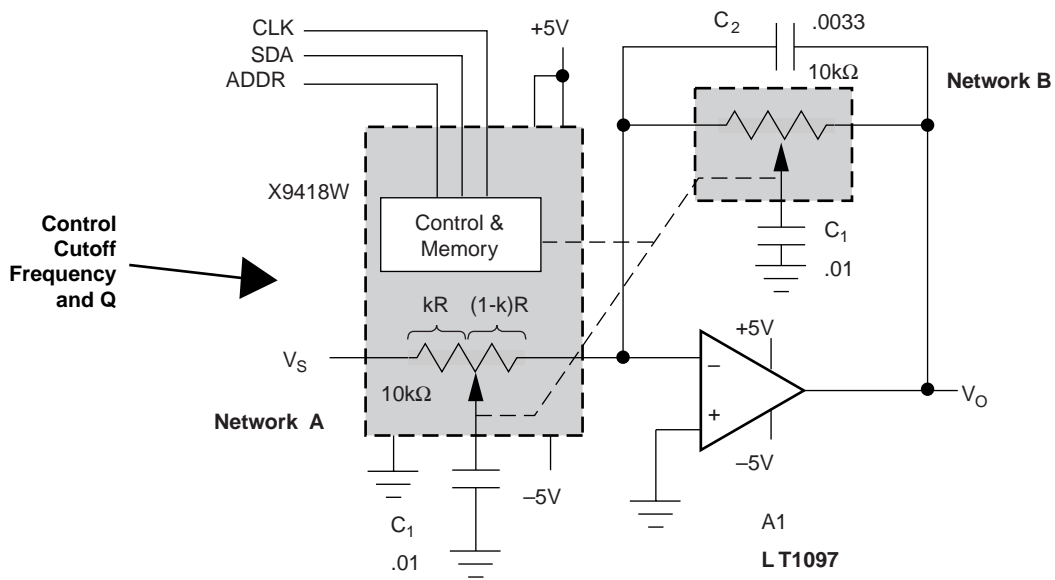

Figure 10. Model of IGSF Filter



$$\frac{V_o}{V_s} = - \frac{Y_{21A}}{Y_{12B}} = \frac{-1/kR(1-k)RC_1C_2}{s^2 + s[1/k(1-k)RC_1] + 1/k(1-k)R^2C_1C_2}$$

$$A_o = -1 \quad \omega_o = \sqrt{\frac{1}{k(1-k)R^2C_1C_2}} \quad Q = \sqrt{\frac{k(1-k)C_1}{C_2}}$$

MFM RESPONSE: $k = 13/63$, $Q = .704$, $f_c = 6.85\text{kHz}$

Figure 11. IGSF Filter with Tee Networks

and

$$Q = \sqrt{\frac{k(1-k)C_1}{C_2}}$$

The movement of the wiper described by $k(1-k)$ in the expressions for ω_0 and Q is parabolic. Depending on the application, the digitally controlled potentiometers can be programmed to optimize the characteristic frequency ω_0 or the quality factor Q . The accuracy of filter parameters is dependent on the component sensitivities and the tolerances of the component values. Precise values of the parameters are difficult to achieve because precise values of capacitance are limited and expensive. This limitation in performance can be overcome using the programmable tee network. The X9418 is dual potentiometer device with a 2-wire (I²C) interface and the ganging of the potentiometer wipers is done through the software.

For the circuit values shown in Figure 11, the filter can be programmed for a theoretical maximally flat magnitude (MFM or Butterworth) response when $k=13/63$. For this value of k , $Q=0.704$ and $f_c = 6.85\text{kHz}$. The measured response for this setting is shown in Figure 12. When the programmable tee network is at its limits ($k=0$ or $k=1$), the circuit reduces to a first order low pass RC filter whose cutoff frequency is determined by the $10\text{k}\Omega$ resistance of the potentiometer and C_2 .

The electronic potentiometer adds variability to the filter circuit and its digital controls, through its computer-controlled serial bus, provides programmability. An automated closed-loop calibration procedure to program or calibrate the filter saves test time and provides enhanced performance and security. *(published in Electronic Design, October 4, 1999)*

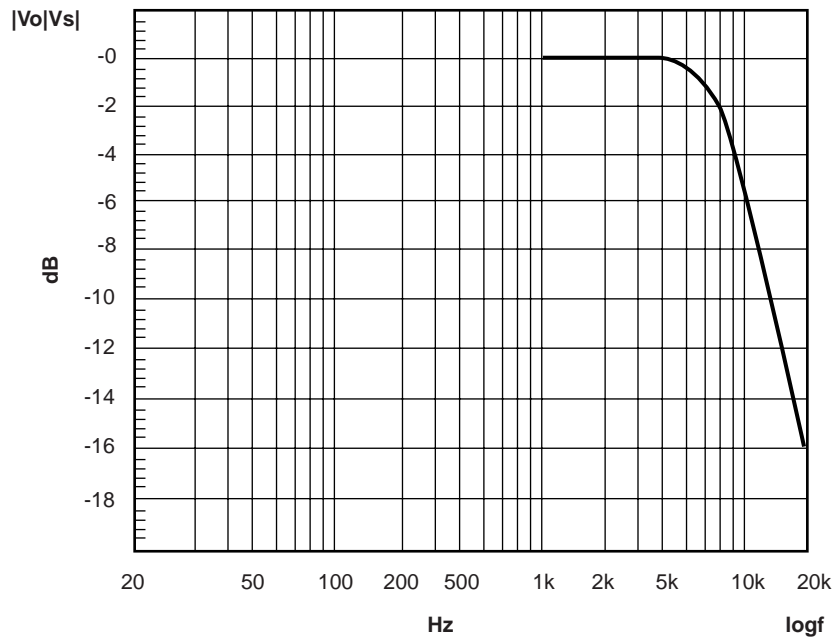

Figure 12. MFM Response of IGSF Filter

I to V Convertor

The circuit in Figure 13 is an input current (I) to output voltage (V) convertor. The feedback portion of the circuit is a tee network of resistive elements consisting of a digitally controlled potentiometer and a fixed resistor R₁(=R). The input-output relationship for the I to V convertor is

$$\frac{V_o}{I_s} = -R \frac{(1+k-k^2)}{k}$$

where k is a number that varies from 0 to 1 and reflects the proportionate position of the wiper from one end (0) of the potentiometer to the other end (1). The programming of the location of the wiper changes the scale factor between the input current and output voltage without changing the values of any of the resistances and avoids the use of high value resistors in measuring low values of current. As k goes from 1 to 0, the scale factor goes from -R (1) to a theoretical -R(∞). The high impedance output of many transducers, like photodiodes and photovoltaic cells, is modeled as a current source.

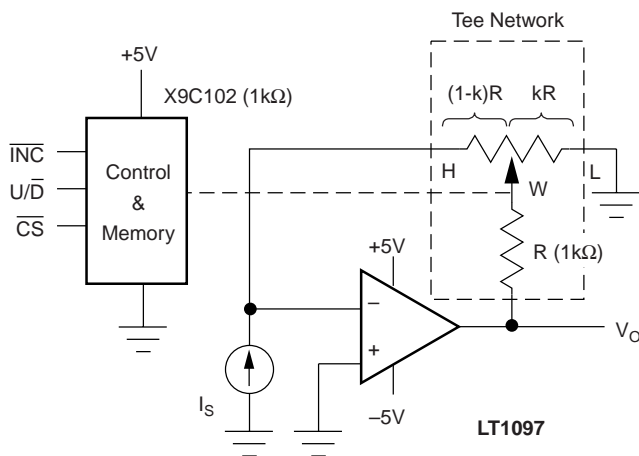

$$\frac{V_o}{I_s} = -R \frac{1+k-k^2}{k}$$

1μA < I_s < 1mA

Figure 13. I to V Convertor

The programming of the 100 tap potentiometer provides for a two-decade change in effective resistance thus allowing the circuit to measure at least three decades of current. For the values shown, the circuit can measure current from 1μA to 1mA.

If we connect the tee network as shown shown in Figure 14, the expression for the scale factor changes to a parabolic-like expression given as -R(1+k-k²). This network can also be used in the traditional inverting amplifier circuit, Figure 15, to provide a variable gain described by

$$\frac{V_o}{V_s} = -\frac{R(1+k-k^2)}{R_1}$$

As k goes from 1 to 0, the magnitude of the gain goes from R/R₁ to 1.25 (R/R₁) to R/R₁ thus providing for a 25% variation in the circuit's voltage gain. Tee-like Network

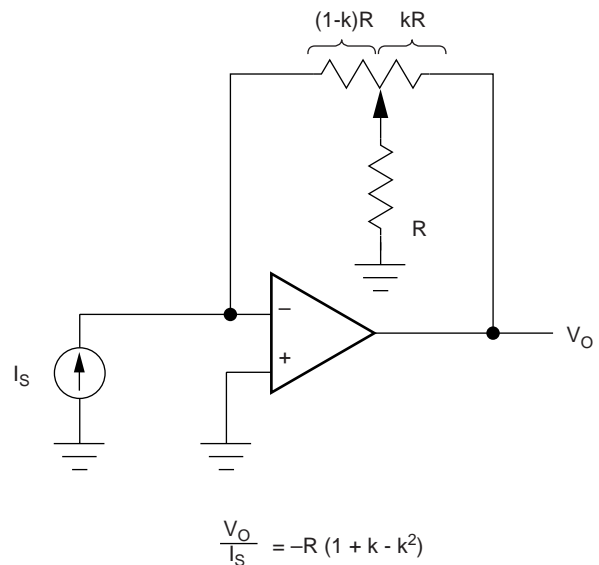

Figure 14. I to V Convertor (version 2)

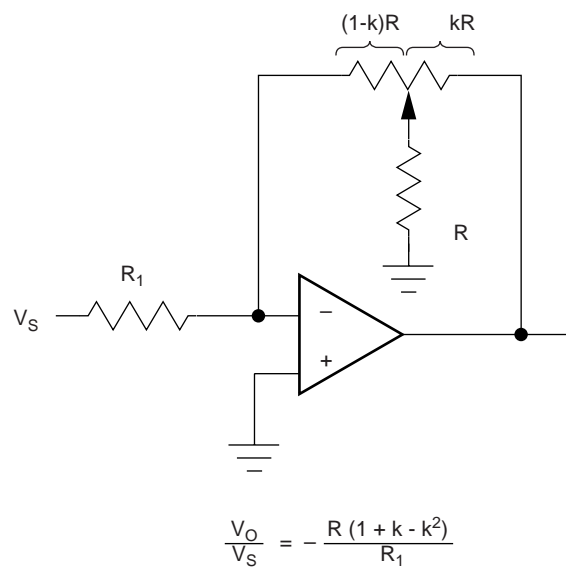

Figure 15. Amplifier with Variable Gain



LittleDiode supplies new, hard to find or obsolete electronic components and semiconductors all over the world.

With over two million different components listed you are sure to find the part you need.

Feel free to visit us today at our online store:

LittleDiode.com

Looking forward to providing you with the best possible service.