



**L6574 & MICROCONTROLLER
IN BALLAST APPLICATIONS**

by Francesca Sandrini and Luca Rodeschini

There is an increasing demand for flexibility in ballast applications. This means a request for having ballast that can be used for different tubes without changing the soldered components. The aim is to save money by using less parts (resistors, capacitors and so on) and less ballast models to be stored and managed.

A way that is going to be investigated is the use of microcontroller which can “supervise” the application in such a way that the key parameters of the application can be modified according to the tube characteristics just by changing the micro-code.

In this application note we will exploit a way to interface a microcontroller with our integrated ballast controller: the L6574.

1.0 INTRODUCTION

Roughly speaking a HF-TL ballast converts the 50-60Hz input to a high frequency output, usually in the range of 25-125KHz.

A rectifier block and a DC to high frequency inverter usually make up a ballast. The half bridge of the inverter can be driven in different ways with different ICs.

We will focus on a specific driver: the L6574. We will see first how the L6574 can drive and control a ballast, then how it can communicate and be supervised by a μ C.

The aim of this paper is to examine if there are advantages in having a μ C work with L6574, the feasibility of this “cooperation”, and a practical example.

2.0 L6574

L6574 is a BCD off line 16 pin IC specifically designed for ballast applications [ref.1](see fig.1). It has both driver functions and controller functions on board.

The most useful characteristics to control the lamp are:

- Preheat and frequency shifting timing
- Cmos shut down input
- Sense op-amp for closed loop control or protection failures

The parameters of the application are set by external components (resistors and capacitors) connected to the IC. L6574 allows the user to set all the parameters according to the lamp characteristics, and the ballast will be a high performance one. There is a specific application note on this IC (ref. [2]): here you find the description of 58W TL ballast with PFC section. Please refer to this application note and to the L6574 datasheet for the IC details. In the following paragraphs we will focus our attention on a way to interface the L6574 with the microcontroller rather than on “L6574 - stand alone” performances. The aim of this “supervision” is to control the three points mentioned above.

Figure 1. L6574 Block Diagram

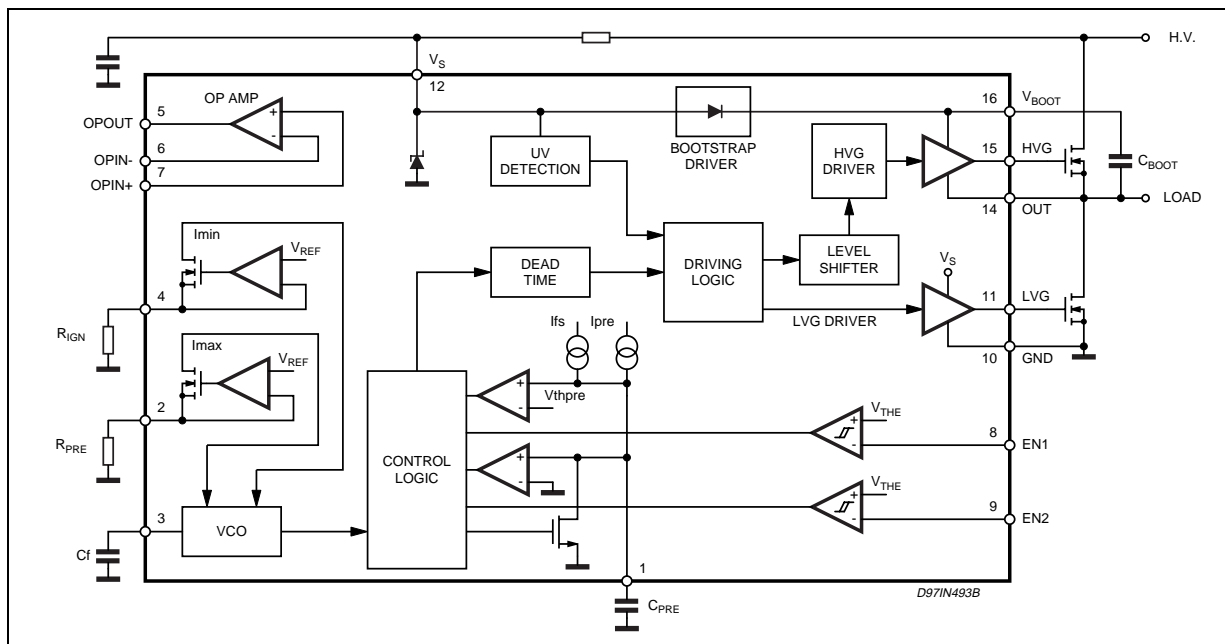

3.0 L6574: HOW TO SET FREQUENCIES, TIMING, FAULT SIGNALS IN AN “ANALOG APPLICATION”

In this paragraph we will have a snap shot of the L6574 working, just as far as the characteristics important for the micro interface are concerned. For further details please refer to [1] and [2].

The L6574 typical behavior is shown in fig. 2: there is a starting frequency (f_{MAX} or f_{PRE}) that is constant for a set preheat time T_{PRE} , than there is a frequency shift towards f_{min} that last 0.1 of T_{PRE} and is called T_{IGN} or T_{SH} .

Figure 2. Frequency shift

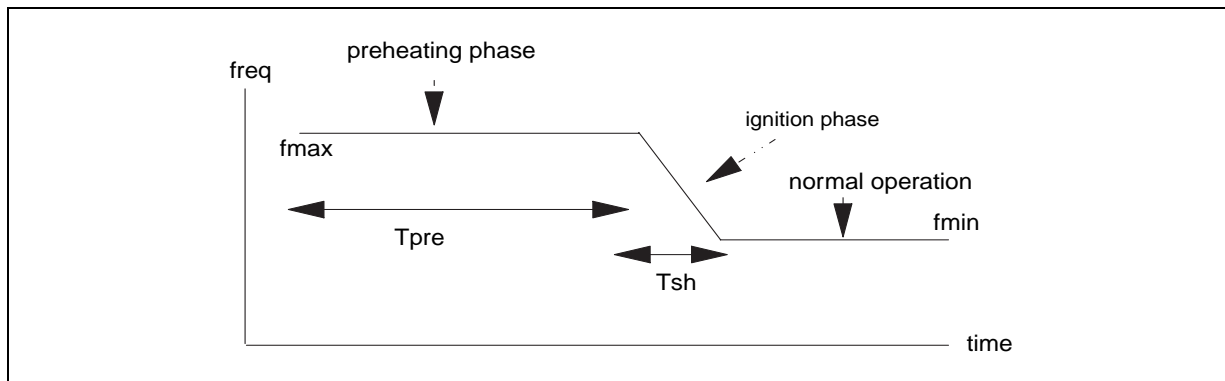

Leads 1, 2, 3, 4 are used to set frequencies and timing.

The capacitor connected to pin 1[CPRE] sets the preheat time:

$$T_{PRE} = K1 \cdot C_{PRE}$$

The ignition time, or better, the time to let frequency shift from preheat value to the min. value is one tenth of T_{PRE} .

The current that charges and discharges the capacitor connected to pin 3 (C_F) sets the half bridge oscillating frequency.

The current that charges C_F is set by the current that flows out from pin 2 and 4 during preheat and from pin 4

AN1320 APPLICATION NOTE

alone during the on phase. As pin 2 and 4 are at 2V, the currents that flow out of them is inversely proportional to the resistance connected between gnd and pin 2 (R_{PRE}) and between gnd and pin 4 (R_{IGN}).

There are some useful formula:

$$f_{\max} = \frac{1.41 \cdot (R_{pre} + R_{ign})}{R_{pre} \cdot R_{ign} \cdot Cf}$$

$$f_{\min} = \frac{1.41}{R_{ign} \cdot Cf}$$

Choosing properly the resistor and the capacitor values the designer can set the desired frequencies and timing. When the designer has to do another application for another lamp type, he has to change the resistors and capacitors in order to have another range of frequencies.

For protection in case of lamp failure two logic input are provided: pin8 [EN1] and pin9 [EN2]. Both are active high, but they have different functions: when EN2 is activated it forces the IC to start again the preheat sequence. When EN1 is activated it shut down the IC until V_{CC} is removed or until EN2 is pulled high.

EN2 is usually used as "ignition fault": if the lamp is not ignited, the preheat sequence starts again.

EN1 can be used to sense lamp removal / replacement or disconnection.

Figure 3. EN1

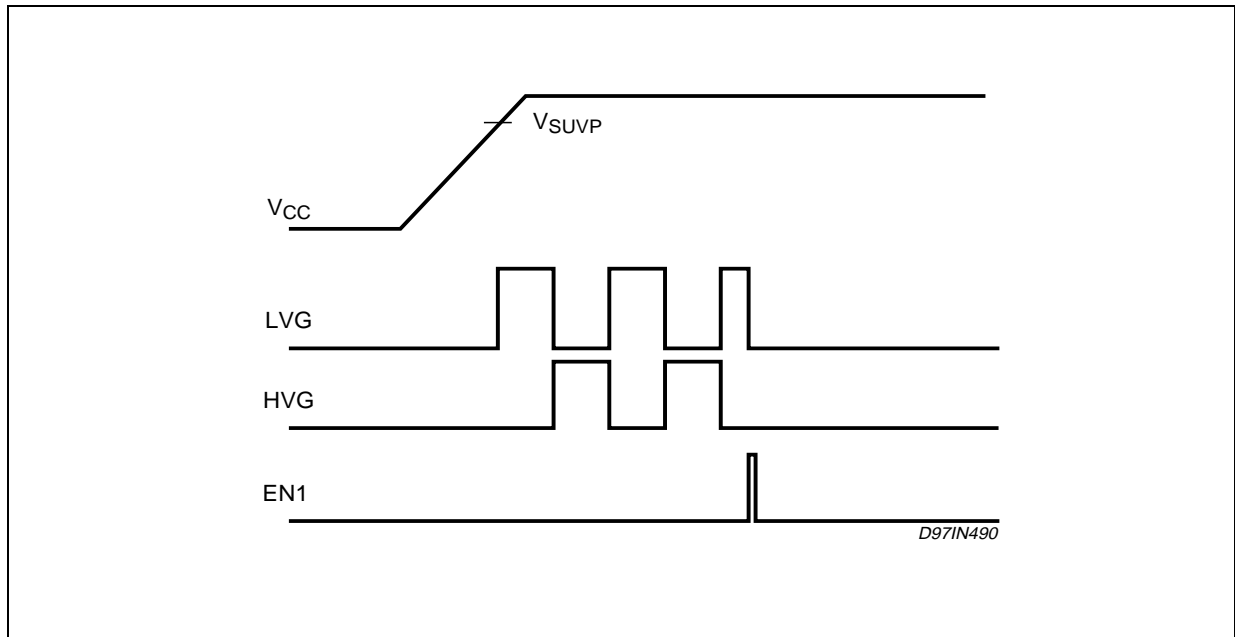
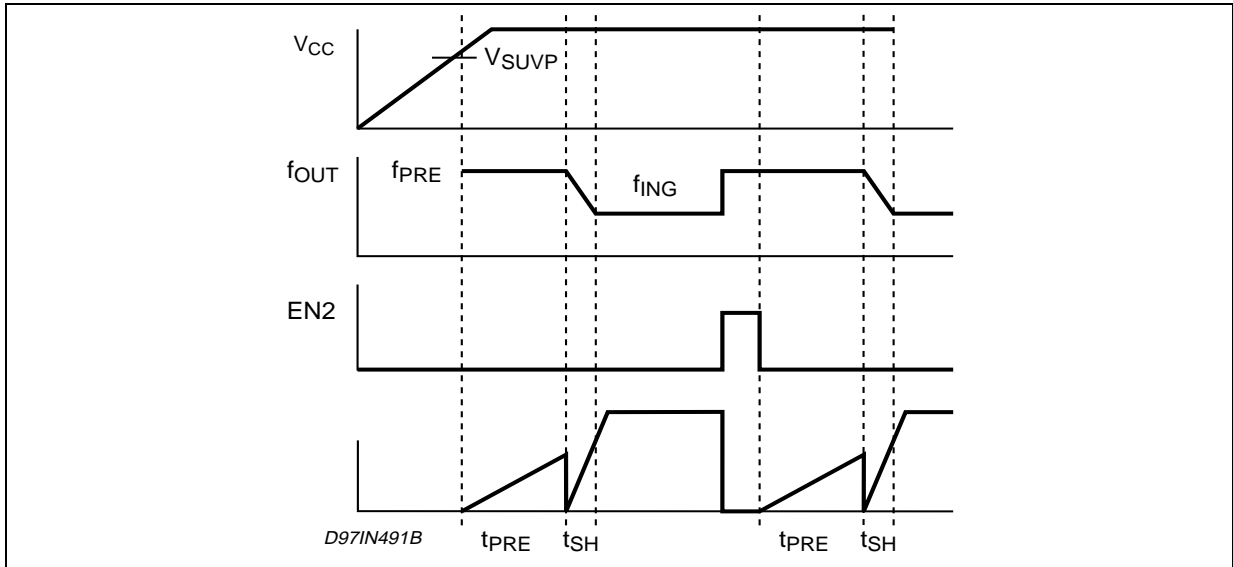

Figure 4. EN2



L6574 has also a sense op-amp that can be used to have a closed loop control of the lamp. We can give a voltage reference to the non-inverting input, a signal proportional to the load current to the inverting input, and we can connect the op amp output pin to pin #4. In this way if the current in the load exceeds the reference the op amp will sink from pin 4 an additional amount of current that has to be added to the current that flows through R_{IGN} . So the current charging C_F will increase, that means a higher half bridge oscillation frequency, that means a lower current in the load. Changing the reference voltage on the non-inverting input of the op amp we change the frequency of the oscillator, that means we change the current in the load, and this allows lamp dimming.

Figure 5. Closed Loop

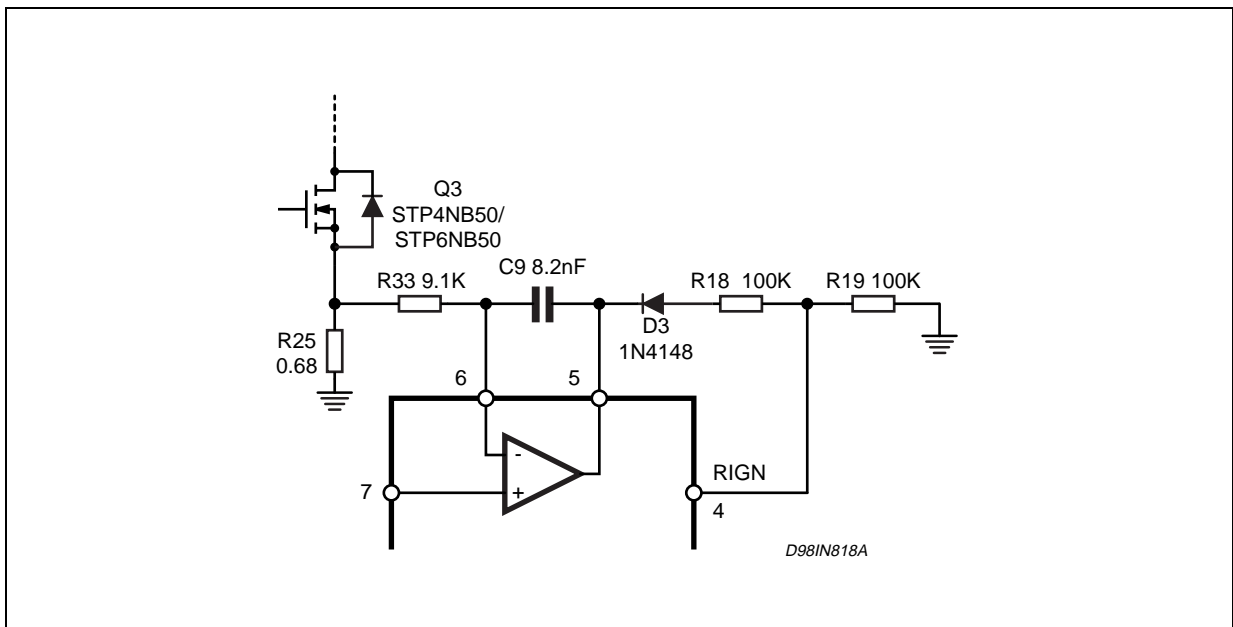
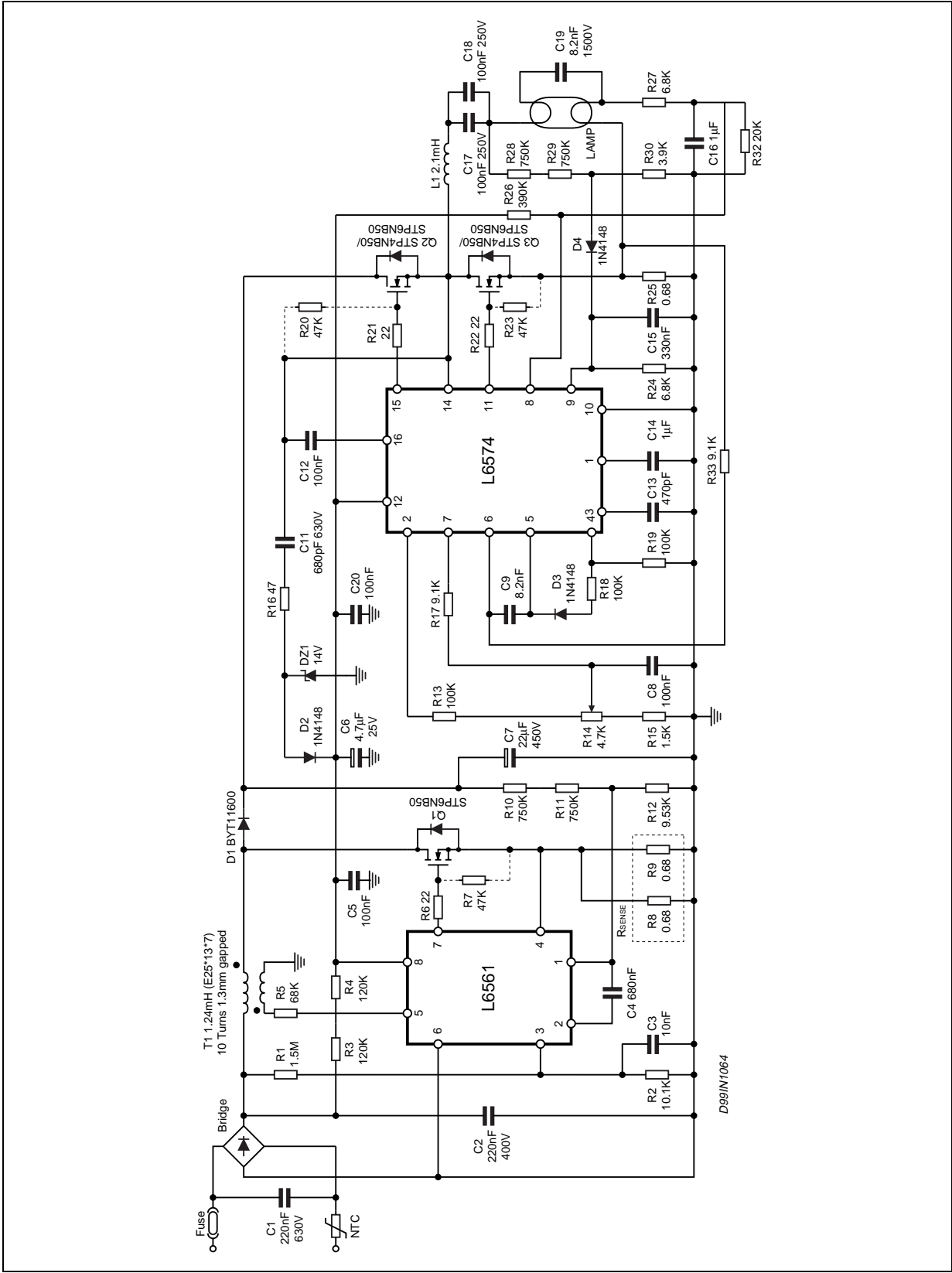

Figure 6. AN993 Demo Application Circuit



4.0 L6574: HOW TO SET FREQUENCIES, TIMING, FAULT SIGNALS IN A “MICROCONTROLLED APPLICATION”

We have seen that the frequencies in L6574 are set by fixing the current that flows out from pin 2 and 4 and fixing the value of the C_F capacitor.

A microcontroller output pin can give us a high logic level (5V) a low logic one (0V) or a PWM output at fixed frequency and variable duty cycle.

We can not use the PWM to act directly on C_F pin, because the rising edge on C_F is the low side mosfet “on time” and the falling edge is the high side mosfet one. The half bridge would oscillate in asymmetrical way at fixed frequency instead of at 50% duty cycle and variable frequency. So we have to interface the μC with the pins that set the current that charges C_F . A push pull output that gives us just 0V or 5V can not be used to interface pin 2 and 4 because they have a maximum voltage level up to 2V. We have to use the integrated value of a PWM signal to set a voltage level between 0V and 2V.

We can use a PWM output also to give the op amp the voltage reference to change the load current (and so the lamp power to perform dimming)

Acting on L6574 pin 4 and (or) on pin 7 (opamp+) we can control the inverter working frequency.

If we want to control the preheat timing and frequency we have to act on pins 2 and 1. First we have to avoid that the L6574 fixes the preheat time by itself. If we connect to pin 1 a very small cap (e.g. 1nF), the L6574 “analog T_{PRE} ” will be so small to be “invisible” to the lamp (i.e. less than 2ms). During these 2 ms, the oscillating frequency has to be high enough to avoid lamp filaments preheat (> 150KHz). The resistor connected to pin 2 has to be sized properly.

After these 2 ms L6574 is in “working mode”: it means that pin 4 is no more involved in fixing the frequency. Only C_F and R_{IGN} (pin 3 and 4) set it.

Now the effective preheat time can be decided by the μC just acting on the PWM that gives the voltage reference to pin 4. For example, it can have a certain duty cycle (appropriate for the preheat freq.) for a fixed time, than it can change the duty cycle (i.e. the voltage reference) to set the ignition profile and the final working frequency.

Now we are able to change all the frequencies and the timing involved in lamp turning on and dimming with two connections between L6574 and the μC .

The fault management can also be done by the μC : all the fault signals will be brought to it, and then it will react according to the code. A connection that can be useful is the one to pin 8 (shut down pin) that can be direct because the ICs levels are compatible. In this way the μC can react to a signal either by stopping the inverter or by changing the frequency (i.e. repeating a preheat sequence if there is the no-ignition alarm, or bringing the frequency to a very high value...).

Just with these 3 connection between the L6574 and the μC we can set nearly all the parameters of the application by software.

The number of μC inputs we need for fault signals depends only on what we want to control.

We need another input pin to give the μC the information about the dimming level: this is the interface between the ballast and the “final user”. We can use either switches or an AD input. The first solution is more expensive in terms of number of pin, the AD input requires some attention for the code part but allows a much larger number of levels.

5.0 HOW TO APPLY THIS INTERFACE TO A BALLAST

We started from AN993 demo board to build a μC application with the same performances and some additional degrees of freedom.

We will now apply all the concepts already discussed and put them into a working board.

The hardware and software development can not be separated: it is a very interactive process. Starting from the basic point there are different way to act on the L6574, depending on what we want to be software dependent and what we want to be hardware dependent in the final application.

We will describe the two sections separately just for ease of understanding.

5.1 HARDWARE CHOICES

First we have to choose the μ C. We have chosen the ST62E62C, a 16 pin μ C belonging to the ST6 family.

This device is able to perform all the functions we need with pins left over.

In this microcontroller we have just an auto reload timer, this means that we have just one PWM available. We can call this PWM the **HARDWARE PWM** in the following pages, just to differentiate it from the second one we need and that is obtained by software from a standard output pin. We will call this second PWM the “**SOFTWARE PWM**”

We have discussed in the previous chapters how to interface the μ C and the L6574; the remaining problem is how to supply the ICs.

We have chosen a cheap way to supply the μ C: we use a L7805, which is a linear regulator (5V output). It has been connected to the L6574 supply. This choice (mainly based on economical reasons) has many consequences:

- As L6574 supply is given by a charge pump connected to the middle point of the half bridge, the L6574 has to work (to oscillate) to give the supply to the micro
- The ICs are not supplied at the same time, but as a sequence: the micro (the supervisor) has to be told when everything is OK to start the preheat sequence
- If the L6574 is disabled (after a fault condition for example) the micro no longer has a voltage supply. When the circuit starts again the micro is reset and the program starts from the very beginning

It can happen that the micro must always be supplied, even when L6574 is off. In this case another solution has to be used, e.g. a regulator connected to the rectified mains.

The board start up sequence management takes into account the above mentioned point 1 and 2. Using the start up resistors we let the L6574 start, so its oscillation allows the charge pump work. Then the L6561 is supplied and the L7805 feeds the μ C. This sequence is an inheritance of L6561+L6574 demo board. The co-ordination between the L6574 and the L6561 is done by choosing the start up resistors and the charge pump components. The co-ordination between the micro and the analog part is a mix of hardware and software. By software we let the micro wait for a “power OK” signal from the L6574, that in the meanwhile keeps on oscillating at a very high frequency, so as to let the filament not to be preheated. The L6574 can provide this “power OK” signal for free. The internal sequence of the L6574 charges the preheat cap connected to pin 1 to 5V after the preheat and the ignition sweep has ended. We can deliver this 5V signal to a μ C input, and hereafter the μ C will start to set all the application parameters: in this way we are sure that everything is correctly supplied. Moreover by choosing properly C_{PRE} value (i.e. very small $\sim 1nF$) this “waiting time” is around 2 ms, so it does not influence the overall timing: it is hundreds of time shorter than a typical preheat time.

To be sure that the third condition does not happen and that there are no out of control situations in which we do not know which part of the code the micro is running we have added additional safety circuitry. After the alarm for open load or disconnection, the micro sets an output pin to the high logic level in order to activate an SCR to disconnect the VCC from all the ICs, PFC included. In this way the μ C can supervise not only the L6574 but also the L6561.

5.2 SOFTWARE CHOICES

We have already done some software choose choosing the microcontroller. When we chose a microcontroller with only one PWM output we have already decided to devote a certain amount of microcontroller resources to build the PWM software (see appendix for software details).

A logic sequence of actions could be:

- 1) to check that everything is ok - i.e. all the ICs are supplied in the right way;
- 2) check the presence of the load
- 3) do the preheat sequence
- 4) check lamp ignition
- 5) set the current in the load according to the user input

This is a basic set of functions typical of nearly any ballast application (see fig. 7)

Figure 7. Flow Chart

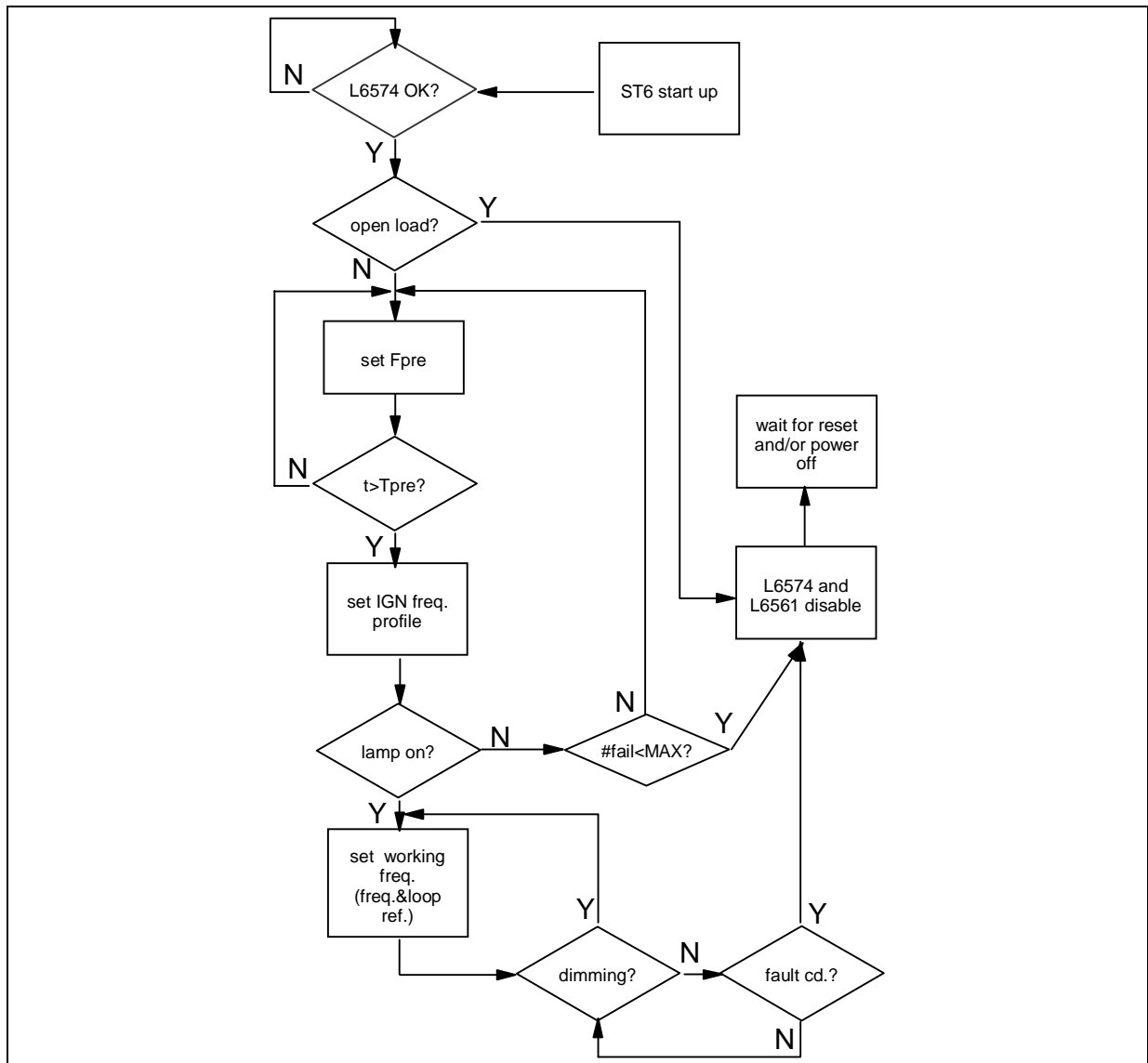

6.0 BOARD

We have implemented the board whose schematic is shown in fig.8.

Figure 8. Schematic

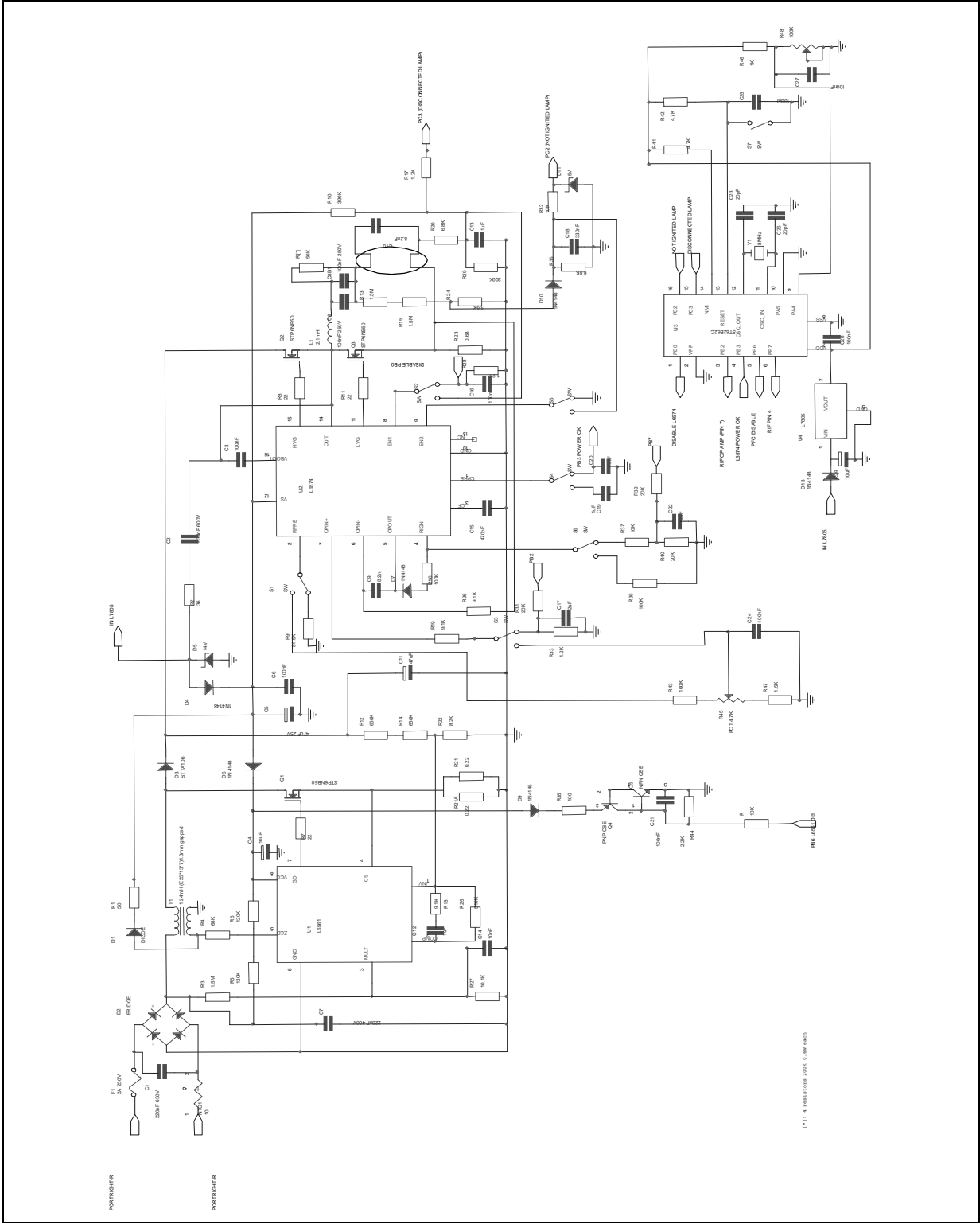

AN1320 APPLICATION NOTE

This is a “double board”: it can be used with the micro or without it according to the position of six switches (S1 to S6) that are on board. The microcontroller, the L7805 and some parts related to the micro (the oscillator, the reset switch and so on) are mounted on a small separated board that can be connected with a 9 pin connector to the main board. As a result the board looks huge, but we have two different application on it. It is a “modular” board: the six switches and the small insertion PCB let the user choose between a “analog ballast” and a “microcontrolled one”.

The larger board includes the “analog ballast controller” (that is the L6561-L6574 demo board) and some additional parts that allows the use of the PCB with the microcontroller and the L7805 regulator. You can choose the control system setting by the proper position of 6 switches:

Analog version			Sw nr.	Function vs. L6574
###	###		SW1	Pin 2 – R _{PRE}
	###	###	SW2	Pin 8 – EN1- shut down
###	###		SW3	Pin 7 – op amp ref. – PWM SW
	###	###	SW4	Pin 1 C _{PRE} – power OK
	###	###	SW5	Pin 9 – EN2
###	###		SW6	Pin 4 – R _{IGN} - PWM HW

Changing all the switch positions the micro can take the control of the board (the control system cannot be changed while the application is running).

The connector that allows the communication between the two boards has 9 signals:

Ref. #	function	Analog ↔ micro
0	Void: there is the hole but it is not connected	
1	GND	↔
2	PB3 (L6574 power OK)	→
3	L7805 input voltage	→
4	PB2 (ref. Op-amp) SW PWM	←
5	PB6 PFC disable	←
6	PB7 ref. Pin 4 = HW PWM	←
7	PC3 disconnected lamp	→
8	PC2 not ignited lamp	→
9	PB0 disable L6574 - EN1	←

The two control system have the same performances, but the microcontrolled application can change its characteristics just changing the code of the micro. If we wish to have a counted number of re-strike of the lamp after ignition failure we can choose any number we want (2, 8 or 23), just changing a parameter of the software. The same can be done if we connect another lamp that needs a different T_{PRE} or a different range of frequencies.

This is an added value of the micro.

An important feature of the overall application is its modularity: we can have a board with the micro and a board without it changing very few parts, we can also put all the parts on the same PCB and then decide which connection to do.

7.0 COMMENTS:

The lamp disconnection fault is managed as an interrupt not only for fast acting, but also for the characteristics of the application we have chosen. The ST62E62C has just a PWM output, while the application needs two PWM. We have solved the problem using the software PWM. This is something very "heavy" for the micro to perform, and it influences all the other choices: e.g. a polling sequence is too expensive as time consuming and it influences the SW PWM duty cycle dynamic. It consumes ~25%-30% of the cycle, and this, added to 20% due to the 4 instructions to do the PWM itself was too large. That is the main reason why the disconnection fault is managed as an interrupt.

Of course there are different solutions. A feasible choice could be to use the hardware PWM to set the reference of the non inverting input and not to use the software PWM. But we should rely on the L6574 preheat and ignition sequence, where T_{PRE} , f_{PRE} and T_{IGN} are set by capacitors and resistors. This means that the μC has to supervise less items.

A third choice might be to choose a μC with two PWM output: in this way the application has the same characteristics and the μC has an easier code to run.

8.0 REFERENCES:

- 1] L6574 datasheet
- 2] AN993: electronic ballast with PFC using L6574 and L6561
- 3] ST62E62C datasheet

9.0 APPENDIX:

- 1) Flow Chart
- 2) Vardef.inc
- 3) Ballast.asm

9.1 APPENDIX 1: Flow Chart

Figure 9. Appendix 1: Flow Chart

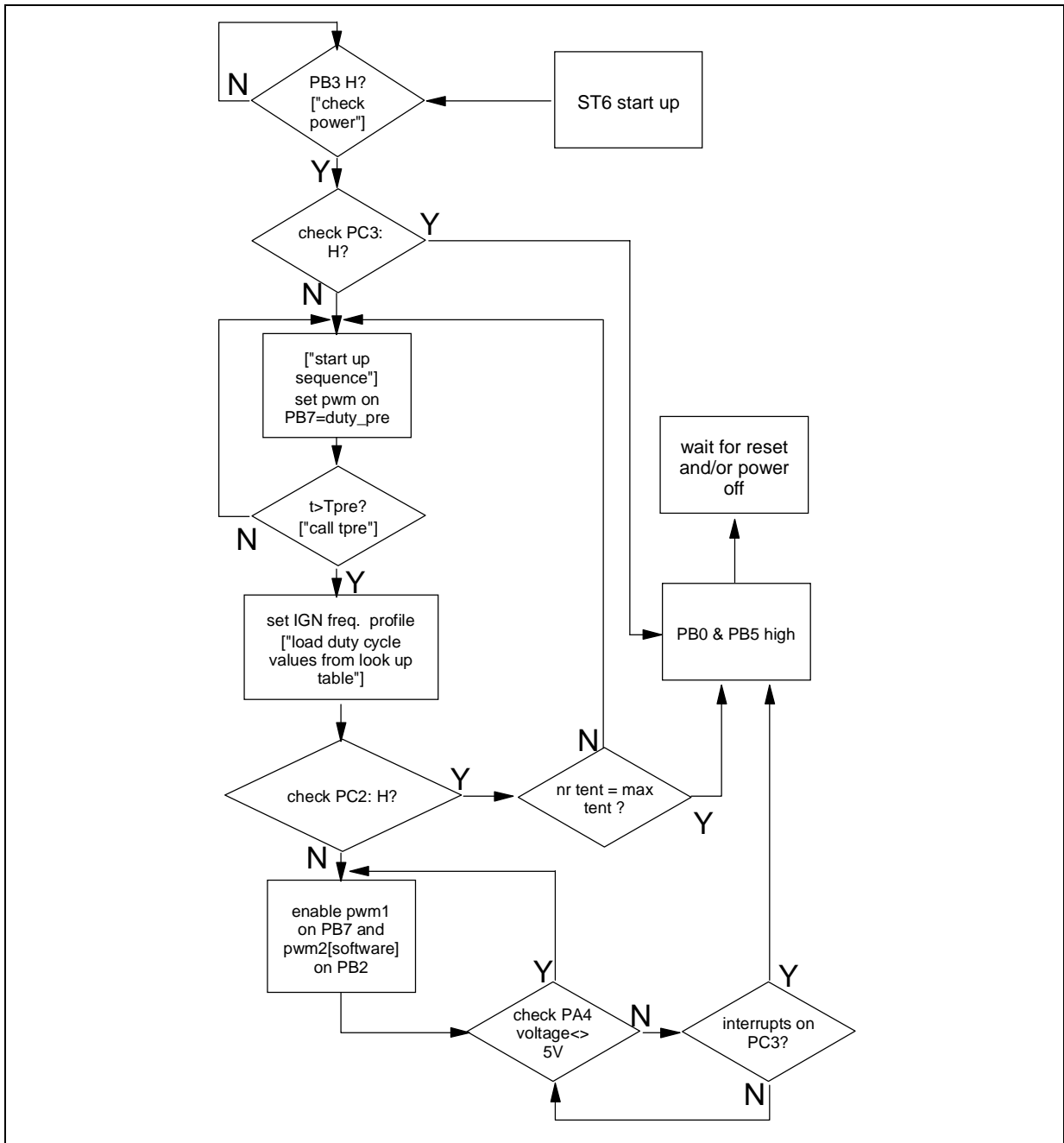

9.2 Appendix 2 - Vardef.inc

```

*****
;
;
;           MODULE Name:  VarDef.Inc
;
;
*****
; *** Default duty cycle value for preheating
DUTY_PRE   .EQU          0BEh
; *** Maximum start-up sequence retrials
MAX_TENT   .EQU          3h

; *** Default Sw PWM Duty Cycle
DEF_SW_DUTY.EQU          0BCh

; *** Gen waiting timer parameters
;           Gen Waiting = 2ms
;           GenTick = 11      -> 11*192us = 2.112 ms
;           GenRep = 1
GenTick     .equ          0Bh
GenRepeat   .equ          01h

; *** Tpre waiting timer parameters
; Tpre [0.5 ./ 2 sec] = 1 sec
;           TpreTick = 256     -> 256*192us = 49.152 ms
;           TpreRep = 21      -> 21*49.152ms = 1.032 s
TpreTick    .equ          0FFh
TpreRepeat  .equ          015h

; *** Tign waiting timer parameters
; Tign [(100 ./ 200)/64 msec] = 150/64 msec = 2.34 ms
;           TignTick = 12      -> 12*192us = 2.3 ms
;           TignRep = 1
TignTick    .equ          0Ch
TignRepeat  .equ          01h

; *** Tad waiting timer parameters
; Tad = c.a 500 ms
;           TadTick = 256     -> 256*192us = 49.152 ms
;           TadRep = 10      -> 10*49.152ms = 491 ms
TadTick     .equ          0FFh
TadRepeat   .equ          0Ah

.ORG        0F00H
; Look-up table for PWM
;           *HW* *SW*
.BYTE       0BCH,0B4H           ; Samp = 0
.BYTE       0C1H,0C8H
.BYTE       0C2H,0CBH
.BYTE       0C4H,0CEH
.BYTE       0C6H,0D2H
.BYTE       0CBH,0DBH
.BYTE       0D0H,0E6H
.BYTE       0D5H,0FEH           ; Samp = 7

```

AN1320 APPLICATION NOTE

9.3 Appendix 3 - ballast.asm

```
*****
;
;
;           MODULE Name:  Ballast.asm
;
;
*****

.romsize 4
.vers "st6262"
.input "ST626x.INI"; ST626x data space & registers declaration
.input "VarDef.inc"

;=====
; Data Variables
;=====

Step      .DEF      084H,0FFH,0FFH,M
Repeat    .DEF      085H,0FFH,0FFH,M
NrTent    .DEF      086H,0FFH,0FFH,M
Media     .DEF      087H,0FFH,0FFH,M
Count     .DEF      088H,0FFH,0FFH,M
Sample    .DEF      089H,0FFH,0FFH,M

;=====
; Ignition Sweep PWM Parameters
;=====

.ORG      0F40H
.BYTE     0BEH,0BEH,0BEH,0BFH,0BFH,0BFH,0C0H,0C0H
.BYTE     0C0H,0C1H,0C1H,0C1H,0C2H,0C2H,0C2H,0C3H
.BYTE     0C3H,0C3H,0C4H,0C4H,0C4H,0C5H,0C5H,0C5H
.BYTE     0C6H,0C6H,0C6H,0C7H,0C7H,0C7H,0C8H,0C8H
.BYTE     0C8H,0C9H,0C9H,0C9H,0CAH,0CAH,0CAH,0CBH
.BYTE     0CBH,0CBH,0CCH,0CCH,0CCH,0CDH,0CDH,0CDH
.BYTE     0CEH,0CEH,0CFH,0CFH,0D0H,0D0H,0D1H,0D1H
.BYTE     0D1H,0D2H,0D2H,0D2H,0D3H,0D3H,0D3H,0D3H

;=====
;           Inizialisation
;=====

.org 880h

Init
    reti
    clr      IOR                ; Disable Interrupts (Confirm Reset Value)

; *** Oscillator and internal Timer
    ldi     OSCR,08h            ; Set Prescaler ratio @ 1
    ldi     TSCR,27h           ; Timer1 no int, presc 128, lock

; *** Port configuration
; Port A: All Input, No Interrupt, Pulled up, except PA4 Analog - PA4 = A/D (in), PA5 = N/C
    ldi     DRA,10h
    clr     DDRA
    ldi     OPRA,10h
; Port B: port 2,6 and 7 output 0, push pull, value 1; port 3 input
;
;           PB0 = 6574 Disable PB2 = SW PWM (out), PB3 = POWER OK (in),
;           PB6 = PFC Disable (out), PB7 = HW PWM - AutoReload Timer (out)
    clr     DRB
    ldi     DDRB,0C5H
    ldi     OPRB,0C5H
```



```

; Port C: All Input, No Interrupt, Pulled up (PC2 = NO IGN(in), PC3 = DISC LAMP (in))
    clr        DRC
    clr        DDRC
    clr        OPRC

; Data Rom Window Configuration
    ldi        DRWR,3DH                ; = (0F40H >> 6)

; Default Duty Cycle value on SwPWM
    ldi        V,DEF_SW_DUTY          ; V = Duty Cycle
    set        2,DRB                  ; SwPWM Port Set

; A/D Converter setup
    ldi        ADCR,10h               ; AD w/out Interrupt, Turned On

; AR-TIMER Configuration (HwPWM)
    ldi        ARMC,20h               ; Autoreload mode, enabled, stopped, no int enabled
    ldi        ARLR,00h               ; LOAD REGISTER
    ldi        ARRC,80h               ; RELOAD REGISTER
    ldi        ARCP,DUTY_PRE          ; COMPARE REGISTER
    set        7,ARMC                 ; Load ARRC and RESET ARSC1
    res        7,ARMC                 ; STOP Load phase
    ldi        ARSC1,60h              ; Fint, prescaler /8 Fpwm =7.8125KHz
    set        6,ARMC                 ; Start Timer

;=====
; Startup Sequences
;=====
CheckPower
; "Power Ok" test twice
    jrr        3,DRB,CheckPower       ; wait for pin = 1
    ldi        a,GenTick               ; Load tick counter
    ld         x,a
    ldi        a,GenRepeat             ; Load repetition time
    ld         y,a
    call       Wait
    jrr        3,DRB,CheckPower       ; test for pin data steady

LampOK
; *** Test if Lamp is connected
    jrr        3,DRC,StartHeat         ; if connected, go ahead
    ldi        a,GenTick               ; Load tick counter
    ld         x,a
    ldi        a,GenRepeat             ; Load repetition time
    ld         y,a
    call       Wait                   ; Wait
    jrr        3,DRC,StartHeat         ; test twice for steady
    jp         Stoplt                 ; unconnected lamp: RIP

StartHeat
    clr        NrTent                 ; Reset Tentative counter

PreHeat
; *** Preheating waiting time
    ldi        A,DUTY_PRE              ; Set preheating Duty-Cycle
    ld         ARCP,A
    ldi        a,TpreTick              ; Load tick counter
    ld         x,a
    ldi        a,TpreRepeat            ; Load repetition time
    ld         y,a
    call       Wait

```

AN1320 APPLICATION NOTE

```

IgnStart
; *** Ignition sequence
clr          Step                ; Reset lookup table index
Ignition
    ldi      A,40H                ; Load Duty-Cycle value from look-up table
    add     A,Step
    ld      X,A
    ld      A,(X)
    ld      ARCP,A                ; on comparator value
    ldi     a,TignTick            ; Load tick counter
    ld      x,a
    ldi     a,TignRepeat          ; Load repetition time
    ld      y,a
    call    Wait
    inc     Step                  ; Update step counter
    ld      A,Step
    cpi     A,40h                 ; if last value in table
    jrz    Ignited                ; exit
    nop
    nop                            ; else next value
    jp     Ignition

Ignited
    inc     NrTent
    ldi     a,GenTick              ; Load tick counter
    ld      x,a
    ldi     a,GenRepeat            ; Load repetition time
    ld      y,a
    call    Wait
    jrr    2,DRC,LampOn           ; if lamp ignited (PC2=0) go ahead
    ld      A,NrTent
    cpi     A,MAX_TENT            ; if trial number overflows, stop
    jrz    GotoStop
    jp     PreHeat                ; else retry

GotoStop
    jp     StopIt

LampOn
; *** System working, set interrupt on PortC, pin 2 and 3
    clr     IOR
    clr     DDRC
    ldi     OPRC,08H              ; PC3 (No Lamp) INT pull-up
    clr     DRC
    ldi     IOR,30h               ; enable global int, rising edge

; *** Internal timer activation for A/D tracking
    res     3,TSCR                ; Stop Timer 1
    set     6,TSCR                ; Enable interrupt
    ldi     a,TadTick              ; Load tick counter
    ld      TCR,a
    ldi     a,TadRepeat            ; Load repetition time
    ld      Repeat,a
    set     3,TSCR                ; Start Timer

; New Data Rom Window Configuration
    ldi     DRWR,3CH              ; = (0F00H >> 6)

```

```

=====
;
;           Main loop
;
=====
Main
    res      0,ARSC0
    nop

    jrr      0,ARSC0,Main
    res      0,ARSC0
    set      2,DRB           ; Set SwPWM output

SwPWMLoop
    ld       A,ARLR
    cp       A,V
    jrc      SwPWMLoop
    res      2,DRB           ; Reset SwPWM output
    jp       Main

=====
;
;           Routines
;
=====
;
;           Stop all operations and disables chips
;
=====
StopIt
    set      0,DRB           ; Disable 6574
    set      6,DRB           ; Disable PFC

RIP
    jp       RIP           ; Do nothing

=====
;
;           Wait: holds for a time:=x*y*192us
;           x = 192us Ticks number to hold
;           y = Repeat Times
;
=====
Wait
    ld       a,y           ; Load repeat time nr.
    ld       Repeat,a

WaitRestart
    ld       a,x           ; Load Counter Value
    ld       TCR,a
    set      3,TSCR        ; Timer start

WaitTimerExp
    jrr      7,TSCR,WaitTimerExp
    res      7,TSCR        ; Timer expired, reset flag
    dec     Repeat
    ld       a,Repeat
    jrnz    WaitTimerExp  ; WaitAgain
    res      3,TSCR        ; Repetition Timer expired, reset
    ret

=====
;
;           Setup A/D Converter
;
=====
SADC
    clr     Media; Reset Media register
    ldi     Count,04h      ; Init counter
    set     5,ADCR         ; start a/d conversion
    nop
    nop
    set     7,ADCR         ; Enable Interrupt
    ret

```

AN1320 APPLICATION NOTE

```

=====
;
;           Interrupt routines
;
=====

; *** Port A   ; Unused
IPA
    reti

; *** Port C   ; Test if some signal went up
IPC
    ld        W,A                ; save accumulator
    jrs      2,DRC,PC2          ; Test port C, pin 2
PC2End
    jrs      3,DRC,PC3          ; Test port C, pin 3
PC3End
    ld        A,W                ; restore accumulator
    reti

PC2
                                ; PC2 issued
    nop
    nop
    jrr      2,DRC,PC2End      ; Confirm steady on pin
    jp       Stopt            ; Stop operations

PC3
                                ; PC3 issued
    nop
    nop
    jrr      3,DRC,PC3End      ; Confirm steady on pin
    jp       Stopt            ; Stop operations

=====
; DispatchIRQ4: test if timer or AD interrupt
;
=====

DispatchIRQ4
    jrs      7,TSCR,ITIM        ; Test for timer interrupt
    jrs      6,ADCR,IADC       ; Test for AD interrupt
    reti

=====

IADC
    res      7,ADCR            ; Disable Interrupt
    ld        a,ADR            ; Load Sample
    ld        Sample,a
    ld        a,Count          ; Test for maximum sample
    jrnz     Conversion        ; maximum reached
    reti

Conversion
    ld        a,Sample          ; a = Sample
    rlc      a                 ; a = a >> 4
    rlc      a
    rlc      a
    rlc      a
    andi     a,07h             ; 8 levels
    add      a,Media
    ld        Media,a
    dec      Count
    ld        a,Count
    jrz      SetSamp
    set      5,ADCR            ; Enable A/D converter
    nop

```

```

nop
set      7,ADCR          ; Enable Interrupt
reti    ; Restart fo new sample

SetSamp  ld      a,Media          ; Media=+last 4 conversion
        andi   a,01Ch
        rlc   a
        rlc   a
        rlc   a
        rlc   a
        rlc   a
        rlc   a
        rlc   a          ; sample=media/4 (media >> 2)
        ld    Sample,a
        rlc   a          ; offset for table look-up (@ 0x40)
        addi  a,040h
        ld    x,a
        ld    a,(x)
        ld    ARCP,a     ; hw pwm
        inc  x
        ld    a,(x)
        ld    v,a       ; sw pwm
        reti

```

```

=====
ITIM
        ldi   a,TadTick      ; Load tick counter
        ld   TCR,a
        res  7,TSCR         ; Reset Tout Flag
        dec  Repeat
        ld  a,Repeat
        jrnz GetOut        ; WaitAgain
        res  3,TSCR         ; Repetition Timer expired, reset
        call SADC
        ldi  a,TadRepeat    ; Load repetition time
        ld  Repeat,a
        set  3,TSCR        ; Start Timer

GetOut  reti

```

```

=====
ARTInt  reti           ; Autoreload Timer interrupt
INMI    RETI          ; not used

```

.org 0FF0H

```

irq4
irq3    jp      DispatchIRQ4
irq2    jp      ARTInt
irq1    jp      IPC
        jp      IPA
        .block 4
nmi
vrst    jp      INMI
        jp      Init

```

.END



Information furnished is believed to be accurate and reliable. However, STMicroelectronics assumes no responsibility for the consequences of use of such information nor for any infringement of patents or other rights of third parties which may result from its use. No license is granted by implication or otherwise under any patent or patent rights of STMicroelectronics. Specifications mentioned in this publication are subject to change without notice. This publication supersedes and replaces all information previously supplied. STMicroelectronics products are not authorized for use as critical components in life support devices or systems without express written approval of STMicroelectronics.

The ST logo is a registered trademark of STMicroelectronics
© 2000 STMicroelectronics - All Rights Reserved

STMicroelectronics GROUP OF COMPANIES
Australia - Brazil - China - Finland - France - Germany - Hong Kong - India - Italy - Japan - Malaysia - Malta - Morocco - Singapore - Spain
- Sweden - Switzerland - United Kingdom - U.S.A.
<http://www.st.com>



LittleDiode supplies new, hard to find or obsolete electronic components and semiconductors all over the world.

With over two million different components listed you are sure to find the part you need.

Feel free to visit us today at our online store:

LittleDiode.com

Looking forward to providing you with the best possible service.