

CURRENT MEASUREMENT AND LIMITATION IN TD340 BASED MOTOR CONTROL SYSTEMS

by J. CAMIOLO and J-F GARNIER

1. INTRODUCTION

In motor control applications, it is very useful to monitor the current through the motor. The current value is an image of the motor torque which is of great interest for motion control. The over current monitoring can be used to detect end of motion conditions and thus avoid the use of a position sensor. It is also useful to provide security functions like motor stall detection and short circuit protection.

Two main configurations can be used:

- sense resistor between the bottom of the H-bridge and the Gnd line (low side sensing).
- or sense resistor connected between the Vbat line and the top of the H-bridge (high side sensing)

Each configuration has its own advantages and disadvantages, and the choice of the right method depends on the application

This application note describes some solutions that can be used with the TD340, a quad MOSFET driver in H-bridge configuration.

The threshold is set by resistors R17 and R18 from the 5V supply. The R15, C3 network acts as a filter to reject short overcurrent conditions, e.g. at motor startup.

Figure 1 : Low Side Sensing

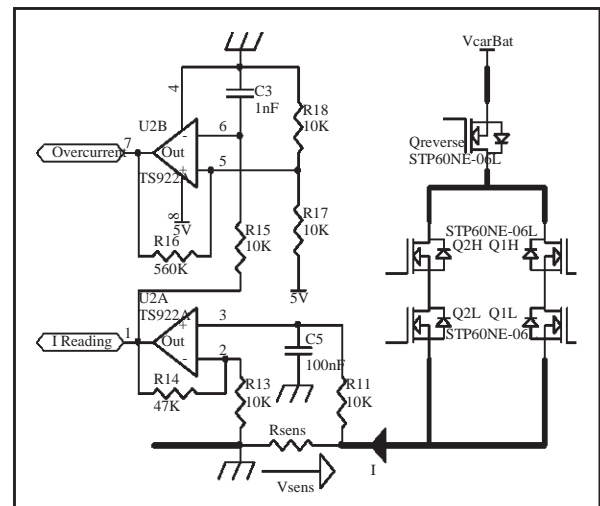

2. SOLUTION WITH THE SENSE RESISTOR CONNECTED IN THE GND WIRE

2.1 Description

Figure 1 shows the operating principle. The dual operational amplifier TS922A (U2A and U2B) is powered by the 5V coming from the TD340. The TS922A is a rail to rail device with a low input offset voltage (0.9mV max.) and is well suited for this application. The voltage across the shunt resistor (V_{sens}) is amplified with the op-amp U2A. The voltage at the op-amp output is:

$$V(I \text{ reading}) = V_{sens} * (R13+R14) / R13$$

The R11, C5 network is used to remove the PWM frequency (25kHz typ.). Cut frequency is about 1kHz, providing a response time of a few milliseconds for the current information.

The second op-amp U2B is used to implement an overcurrent security. U2B is used as a comparator and provides an emergency signal to the μC when an overcurrent occurs.

2.2 Full Schematic

Figure 2 shows the complete application schematic. The current reading signal is connected to a A/D input port of the micro-controller (μC), and the overcurrent signal (active low) is wired to an interrupt input. Furthermore, the overcurrent signal immediately brakes the motor by pulling low the IN1/IN2 lines of the TD340 with diodes D3, D4. This feature provides a fast hardware current limitation. As soon as the current drops below the threshold (including the hysteresis), the IN1/IN2 lines are released and the TD340 is controlled again by the μC .

2.3 Comments

Advantages:

- easiest method,
- precise, low offset, no calibration needed.

Disadvantage:

- unable to detect load shorted to ground.

AN1305 - APPLICATION NOTE

Figure 2 : Low Side Sensing, Full Application Schematic

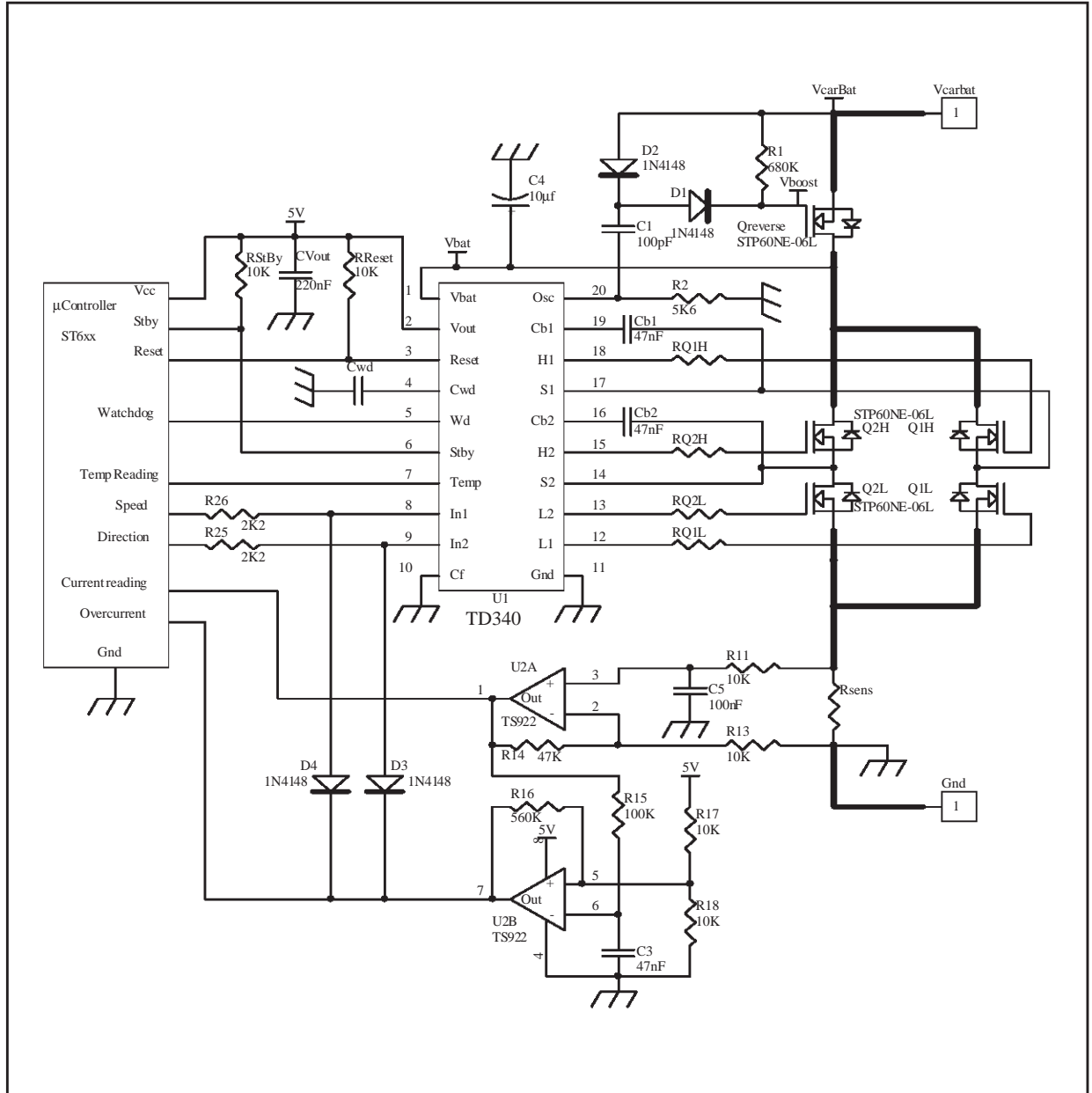

3. SOLUTION WITH THE SENSE RESISTOR CONNECTED IN THE VBATT WIRE

3.1 Description

If a fifth MOSFET is used to protect against battery connection reversal (see the TD340 datasheet), it can be used as a sense resistor. In normal mode the Q transistor is always on and has a very small R_{ds} resistance. An additional advantage from using the MOS resistance is that it provides a lower current limitation at higher temperature as the R_{ds(on)} is increasing. Figure 3 shows the operating principle.

The voltage at the op-amp output is:

$$V(\text{Ireading}) = V_{\text{sens}} * R_{22} / (R_{21} + R_{22}) * R_{14} / (R_{11} + R_{21} // R_{22})$$

R_x//R_y means R_x parallel with R_y. Conditions are: R₁₉=R₂₁, R₂₀=R₂₂, R₁₁=R₁₃ and R₁₂=R₁₄.

Figure 3 : High Side sensing

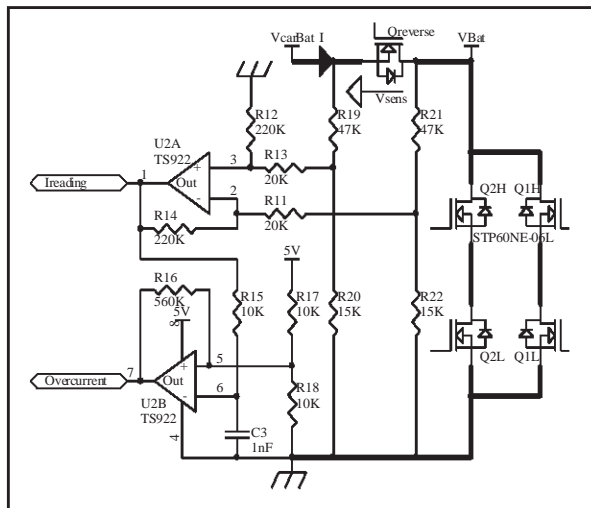

High common mode voltage

The major problem with this configuration is the high common mode voltage at the sense resistor. Moreover, in automotive applications, the V_{batt} voltage can rise to more than 40V during 'load dump' transients. The TD340 can sustain such voltage (up to 60V), but the op-amp has to be protected as well. This can be done with resistor bridges at each side of the sense resistor to lower voltages to acceptable level. Resistor ratio of 1:3 provides a 1/4 attenuation of common voltage that can then rise near to 20V. Greater voltages are not functional but are harmless for the op-amp because the voltages at input pins are clamped by diodes to the 5V supply and the serial resistors limit the current into the input pins to acceptable levels (see figure 4). Of course, differential voltage is reduced as well, a typical 200mV shunt voltage gives only 50mV after the resistor bridge.

Figure 4 : Op-Amp Protection

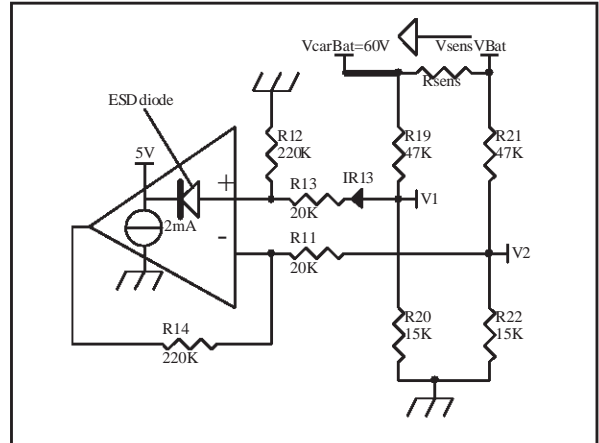

Voltage range

To achieve a good common mode rejection, precision resistors (at least 0.1%) should be used. If the common voltage range is 12V to 16V, the common voltage range after the resistor bridge is 3V to 4V. A 0.1% mismatch between each arm of the resistor bridge produces a change of 1mV differential voltage, i.e. a 2% systematic error (1mV relative to 50mV). Moreover, the 1V common mode voltage change seen by the op-amp also produces an error due to the finite CMRR of the op-amp: 1 mV for a standard 60dB rejection ratio. This shows that this method only works with limited common voltage range.

Offset

The total offset is due to the intrinsic offset of the op-amp, plus the offset due to the various resistor mismatch. As this offset is not negligible, it must be corrected by software. The μC must proceed to an auto zero calibration when the motor is off (at each power-up for example). However, the offset can be positive or negative, so the zero current level at the input of the μC should not be 0V, but a small positive value. This is the purpose of R₂₃ and R₂₄ that provide a shift of about 500mV.

3.2 Full schematic

The full schematic is showed in figure 5 and includes an overcurrent protection built with a second op-amp used as a comparator.

3.3 Comments

- Advantages:
- detection of load shorted to ground,
 - use of the 5th MOSFET as sensing resistor.
- Disadvantages:
- need of high precision resistors,
 - need of a software auto-zero calibration.

4. ALTERNATE SOLUTION WITH THE SENSE RESISTOR CONNECTED IN THE VBATT WIRE

4.1 Description

Using the sense resistor in high side position has a lot of advantage, but is usually difficult to handle. The following schematic (figure 6) shows an alternate solution using a floating op-amp near the Vbatt line.

Figure 6 : High Side Sensing

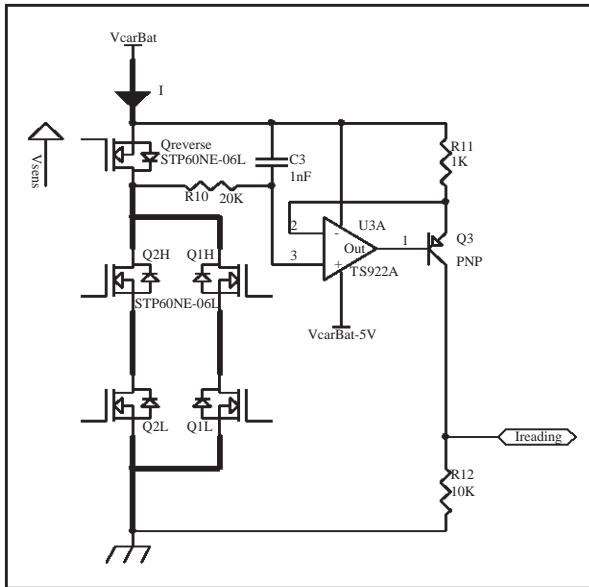

Operation

The principle is to use a op-amp supplied near to Vbatt to measure the differential voltage across the shunt. This op-amp is supplied between Vbatt and an intermediate voltage at about 5V below Vbatt. The op-amp operates close to the upper rail, and converts the shunt voltage into a current by the means of resistor R11 and transistor Q3. Resistor R12 converts back this current into a voltage near the ground level where it can be easily used by the μC or additional circuit.

The I reading voltage is:
 $V(I \text{ reading}) = V_{\text{sens}} * R12 / R11$

4.2 Full schematic

The full schematic (figure 7) includes overcurrent protection build with a independent op-amp used as a comparator. The intermediate voltage for U3 is built with Zener diode Z1 and transistor Q4. If the application have to withstand 'load dump' transients, Q1 and Q4 should be rated at least to 60V.

4.3 Comments

- Advantages:
 -detection of load shorted to ground,
 -precise, low offset, no calibration needed.
 Disadvantages:
 -2 independent op-amps ICs
 -more discrete parts.

5. CONCLUSION

Measuring the current in motor control application is often required. Choosing the right method for current measurement and limitation requires careful reviewing of the advantages and disadvantages of each configuration. For automotive applications, a high side sensing will often be preferred, whereas industrial or cost sensitive applications will use simpler low side sensing.

AN1305 - APPLICATION NOTE

Figure 7 : High Side Sensing with Floating Op-Amp, Full Schematic

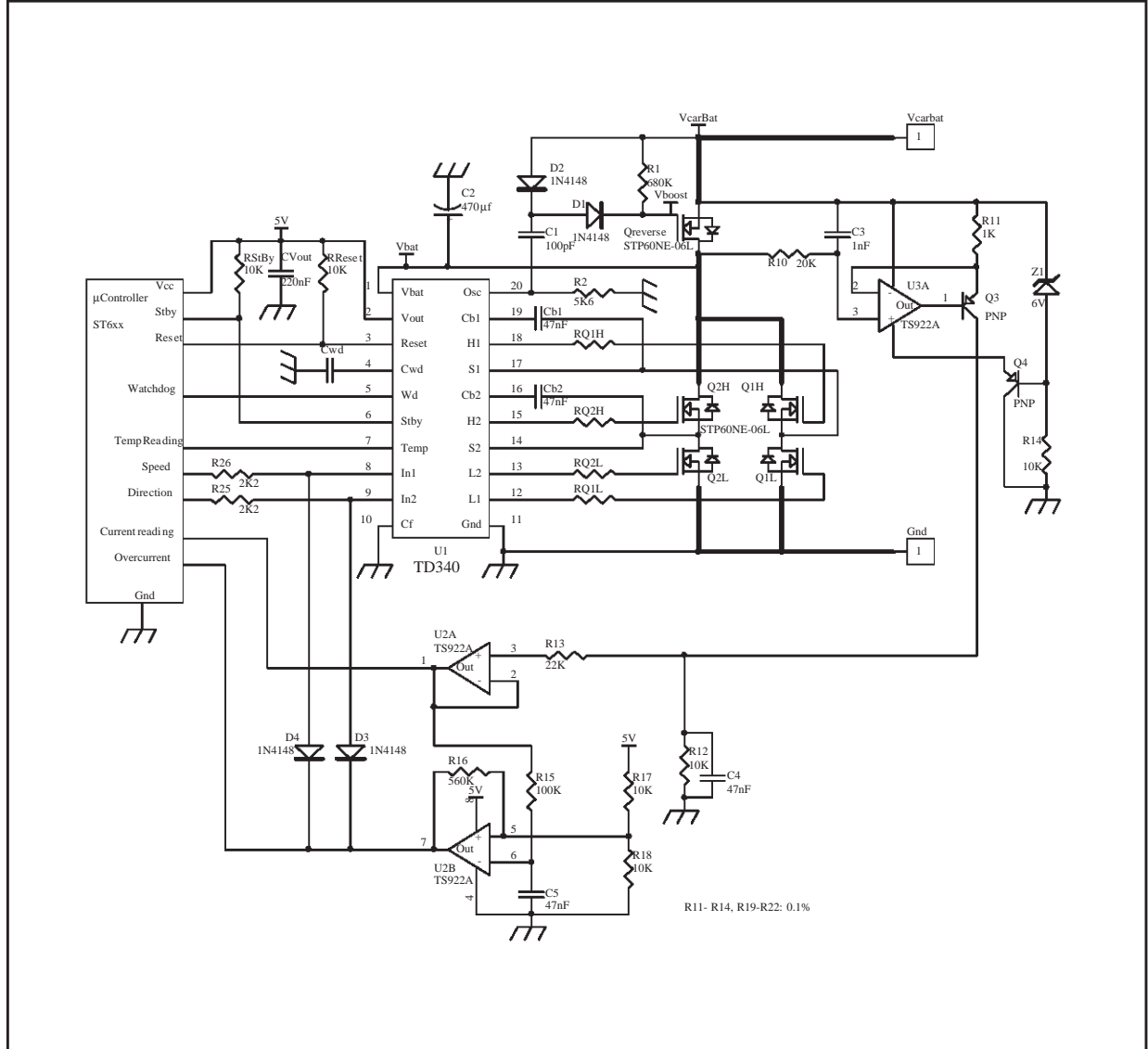

Information furnished is believed to be accurate and reliable. However, STMicroelectronics assumes no responsibility for the consequences of use of such information nor for any infringement of patents or other rights of third parties which may result from its use. No license is granted by implication or otherwise under any patent or patent rights of STMicroelectronics. Specifications mentioned in this publication are subject to change without notice. This publication supersedes and replaces all information previously supplied. STMicroelectronics products are not authorized for use as critical components in life support devices or systems without express written approval of STMicroelectronics.

© The ST logo is a registered trademark of STMicroelectronics

© 2000 STMicroelectronics - Printed in Italy - All Rights Reserved
STMicroelectronics GROUP OF COMPANIES

Australia - Brazil - China - Finland - France - Germany - Hong Kong - India - Italy - Japan - Malaysia - Malta - Morocco
 Singapore - Spain - Sweden - Switzerland - United Kingdom

© <http://www.st.com>





LittleDiode supplies new, hard to find or obsolete electronic components and semiconductors all over the world.

With over two million different components listed you are sure to find the part you need.

Feel free to visit us today at our online store:

LittleDiode.com

Looking forward to providing you with the best possible service.