

RING WAVE TESTS WITH ACS402/ACS108 DRIVING VALVES & PUMPS

L.GONTHIER

1. PURPOSE

In this report, test results performed with ACS402/ACS108 devices are presented in order to analyze their behavior towards standard RING WAVE surges. Note that the behavior of these devices towards 1.2/50 impulse wave is specified on their datasheet.

The test procedure is described in the UL858A standard. The only difference with the tests presented in this paper is that the normalized waveform is directly applied to the semiconductor and the load (refer to Figure 1). As the ACSs are not triggered, they only turn on by overvoltage when the generator voltage exceeds their clamping level. The surge is then applied across the load and the load current flows through the ACS which is in ON state.

No coupling network is used to apply the surges while the system is connected to the mains terminals. This choice was driven by two reasons:

1- in our case, the impedance between the surge generator and the Device Under Test (D.U.T) is only the load one; this enables accurate and repetitive tests.

2- as we demonstrate it in this paper, load insulation layers should flash-over; then, as here the D.U.T is not linked to the mains, the short-circuit will only last a few microseconds instead of a half cycle; this avoids destroying the D.U.T.

As the current conduction during a half mains cycle is not an issue for the D.U.T, and as the only stress for it is the breakover turn-on current, the tests presented here are as stressful as standard ones.

Fig. 1 : Test diagram

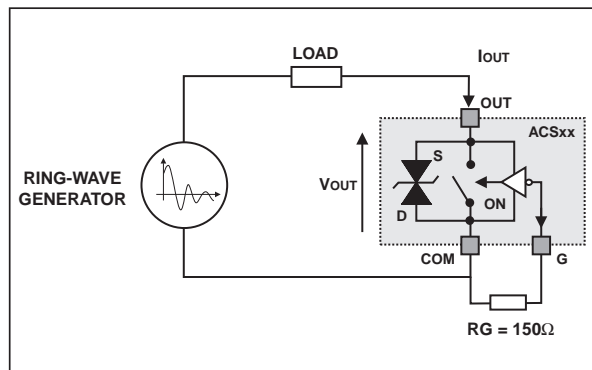

All the following oscillograms have been measured with the equipment listed below:

- Tektronix TDS754A scope;
- Tektronix voltage P6013A probe (1/1000 ratio);
- Eurocraft pulse current transformer (1 V /10 A ratio);
- Tektronix TCP202 current probe.

2. RESULTS

Three kinds of loads have been used during the tests.

2.1 Valve

The valves used are rated 120 V - 50 mA - 60 Hz. Two different behaviours can appear during ring wave test.

- The valve insulation is sufficient: when the ACS turns on the current is limited by the load inductor. Only a capacitive current (approximately 250 mA peak, cf. Figure 2) can be seen during the voltage rise across the switch. Such a turn-on is not stressful to the device.

APPLICATION NOTE

Fig. 2 : 3 kV surge with a well insulated valve.

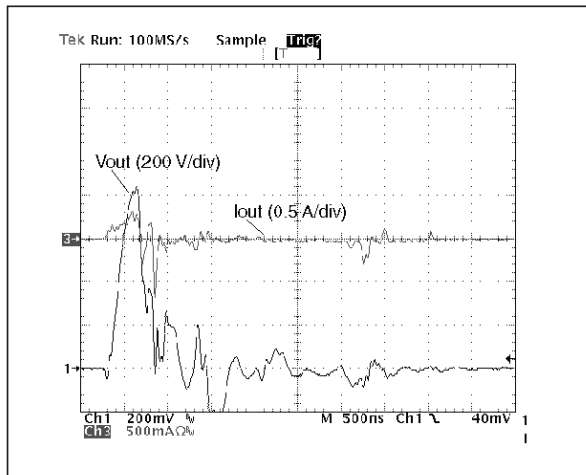

- The valve insulation is not sufficient: in this case, the valve flashes over when the switch turns on, i.e. when the whole surge voltage is applied across the valve. The load behaves like a short-circuit. The ACS current is not limited and can reach up to 120 A (refer to Figure 3). The conduction losses can then be so high that the die silicon can melt or its bonding wires can fuse and cause the destruction of the device package. In practice, as the test is done with the complete system including clamping devices or filters, this behaviour does not occur.

Fig. 3 : 3 kV surge with a bad insulated valve.

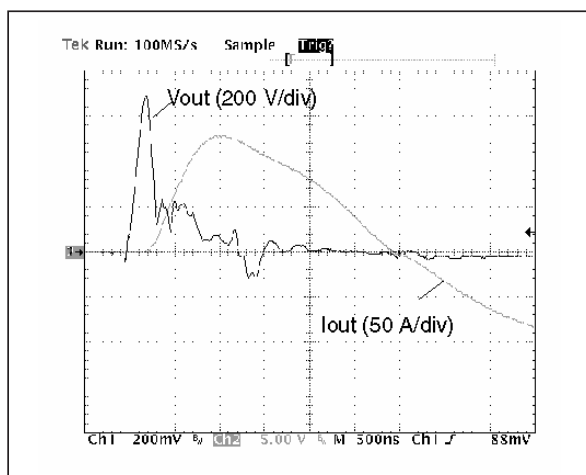

2.2 Pump

The pumps which have been tested are rated 120 V- 700 mA -60 Hz. They withstand the high voltage of the generator up to 6 kV, without flash-over.

Figure 4 shows the behaviour of an ACS with this load. During the breakover of the device, a capacitive current flows through the parasitic capacitor of the load due to the high dV/dt rate applied to it. This current can reach up to 2 A. As the current pulse lasts around 100 ns, there is no thermal issue. ACSs can withstand such a stress without any damage.

Fig. 4 : 6 kV test with the pump.

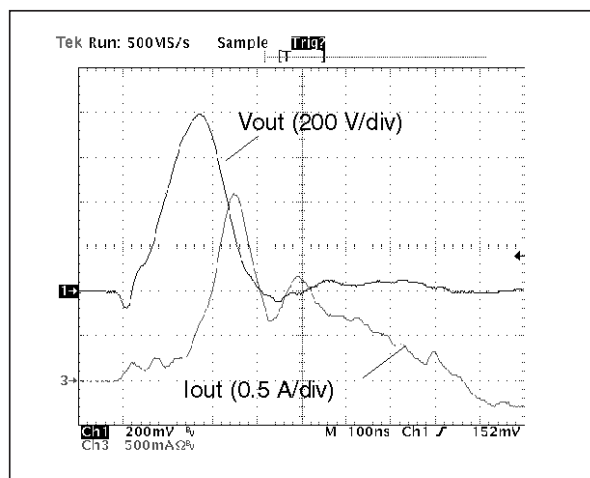

2.3 5W-150 Ohm resistor.

In order to check the good behaviour of ACSs during a ring wave test, whatever the load is, we have performed trials with a 150 Ohm resistor. This value is equivalent to the resistor of a 120 V-10 W light bulb at cold state. The chosen resistors present a serial inductance lower than 3.5 μ H. So, as the device turns on in breakover mode, the current rate of increase is not limited by the load.

This case seems to be the worst one that can appear in practice for ACS402 or ACS108 products (not inductive and low resistive load).

Figure 5 shows a oscillogram for a 6 kV surge. The current reaches up to 57 A, with a 130 A/ μ s rate of increase.

Sixty positive surges and sixty negative surges have been applied, as required in the UL858A standard. Tested devices did not present variation

Fig. 5 : 6 kV ring wave test with a 150 Ohm resistor.

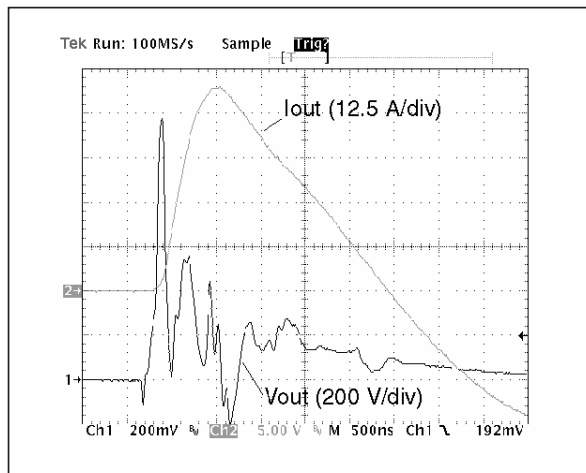

3. CONCLUSION

Ring wave surges, as defined in the UL858A, can be applied on systems including ACSs as long as the used loads are also compatible with the UL858A.

- Valves : 50% of the tested valves sustain the 6 kV surge. In this case, ACSs are compatible with the 100 kHz ringwave defined in the UL858A.
- Pumps : driven by an ACS, it is compatible with the UL858A. These loads can be up to 700 mA. In this case, thermal behaviour has to be monitored to keep the junction below maximum junction temperature.
- For a 150 Ohm resistor, which seems to be the worst case for the power range of the targeted loads, **ACSs are in line with the UL858A standard without any risk of damage.**

To conclude, ACSs comply with the UL858A when the loads are able to withstand the required level of voltage (6kV). If not, a spark gap can be achieved by bringing closer the two non-insulated copper tracks where the mains plug is connected. A 3 mm distance will then reduce the input overvoltages to approximately 3 kV.

Information furnished is believed to be accurate and reliable. However, STMicroelectronics assumes no responsibility for the consequences of use of such information nor for any infringement of patents or other rights of third parties which may result from its use. No license is granted by implication or otherwise under any patent or patent rights of STMicroelectronics. Specifications mentioned in this publication are subject to change without notice. This publication supersedes and replaces all information previously supplied. STMicroelectronics products are not authorized for use as critical components in life support devices or systems without express written approval of STMicroelectronics.

The ST logo is a registered trademark of STMicroelectronics

© 2001 STMicroelectronics - Printed in Italy - All rights reserved.

STMicroelectronics GROUP OF COMPANIES

Australia - Brazil - China - Finland - France - Germany - Hong Kong - India - Italy - Japan - Malaysia
Malta - Morocco - Singapore - Spain - Sweden - Switzerland - United Kingdom - U.S.A.

<http://www.st.com>



LittleDiode supplies new, hard to find or obsolete electronic components and semiconductors all over the world.

With over two million different components listed you are sure to find the part you need.

Feel free to visit us today at our online store:

LittleDiode.com

Looking forward to providing you with the best possible service.