

USING THE VB409 TO SUPPLY A NEGATIVE REGULATED OUTPUT VOLTAGE

G. Nuzzarello - G. Di Stefano

1. ABSTRACT

The purpose of this application note is to present the electrical schematic that allows the use of the VB409 as a -5V output regulator. The VB409 is a fully protected high voltage positive regulator designed in VIPower M1-2 technology. It can be directly connected to the rectified mains supplying a double output: +5V±5% dc and +16V (maximum) non regulated voltage. It has a built-in over current (80mA minimum value) and thermal shut-down (140°C minimum) protection. In the following sections we will explain if and how the VB409 is well suited to be used in application where a -5V is requested.

2. OPERATION DESCRIPTION.

Figure 1: VB409 Block Diagram

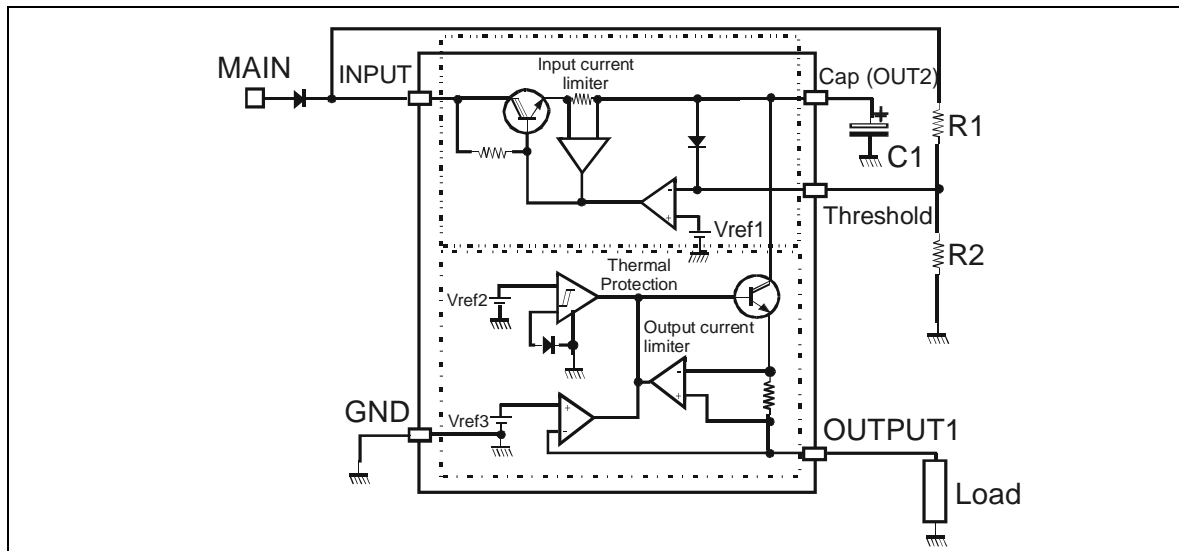

The VB409 block diagram (see figure 1) is divided in two stages: the first stage (on top of the block diagram) is a preregulator which transforms the pulsed voltage, derived from the rectified main on the input (1), to a lower voltage (typically 16V) used to charge an external electrolytic capacitor. The second stage is a standard low voltage regulator able to guarantee ±5% precision on the output regulated voltage (+5V).

The first stage of the VB409 is a trlinton that is driven in such a way to provide current to the connected second stage. The device works by setting the conduction angle (the on time of the trlinton). This means that the current is delivered from the mains only during a “low” voltage portion of each positive half cycle

AN1293 - APPLICATION NOTE

$0-t_1$; $t_2-T/2$ (see the waveform in figure 2b). The result is a drastic reduction of the power dissipated on the device. During the conduction period the current flowing through the trilineon ICL(in) charges the external capacitor and supplies the connected loads. When the voltage on the capacitor reaches a fixed voltage V_{cap} (max), the trilineon is switched off. The load is supplied by the discharge current of the external capacitor C_1 . The proper setting of the conduction angle can be done by dimensioning the R_1 - R_2 divider. To do this two parameters have to be considered:

- 1) the voltage drop between the discharged capacitor and the output1 pin has to be over 2.5V;
- 2) it is necessary not to exceed the SOA limits of the bipolar power stage.

A good compromise will be reached by dimensioning the ratio $R_1/R_2 < 11$. To have more information about the operation of the VB409 you can consult application note AN1219.

Figure 2: VB409 Operation Waveform

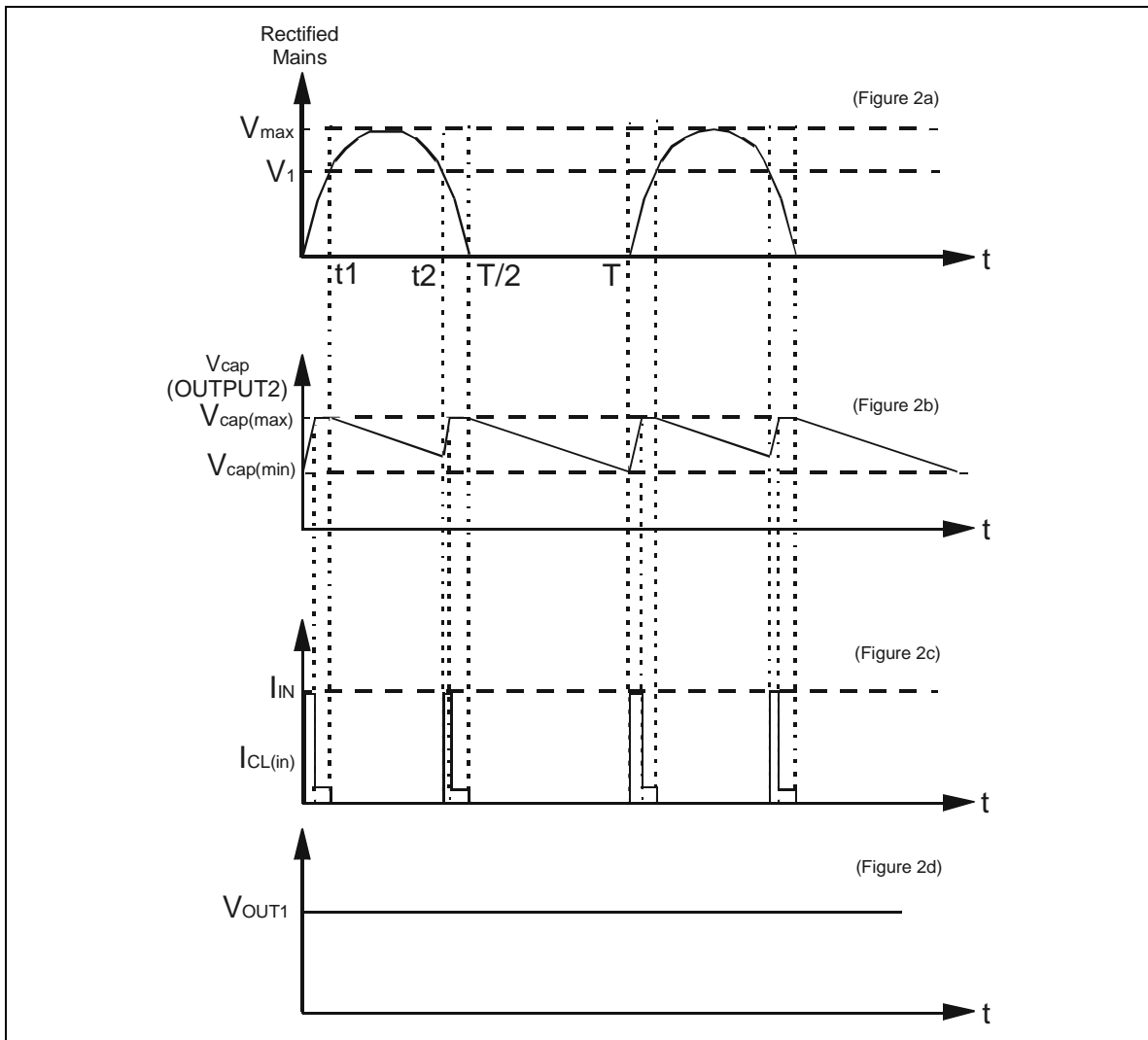

3. ELECTRICAL SCHEMATIC FOR -5V OUTPUT VOLTAGE.

This application note focuses on the way to obtain a negative voltage from the VB409. We are referring to a load made of two resistors, R1 and R2, with the common point connected to the earth (see scheme in figure 3). The electrical scheme is browsed in picture 3: the earth of the supplied load must be connect with the output1 pin.

The output2 (V_{out2}) voltage is referred to the load earth; so the positive voltage on the $R_1=820\text{Ohm}$ resistor is given by the formula:

$$V_{plus} = V_{OUT2} - 5V$$

With the V_{out2} value of 16V (typical value), the equation is $V_{plus}=(16-5)V=11V$. The voltage on the load resistor $R_2=100\text{Ohm}$ is always $-5V\pm 5\%$.

Figure 3: -5V Application Schematic

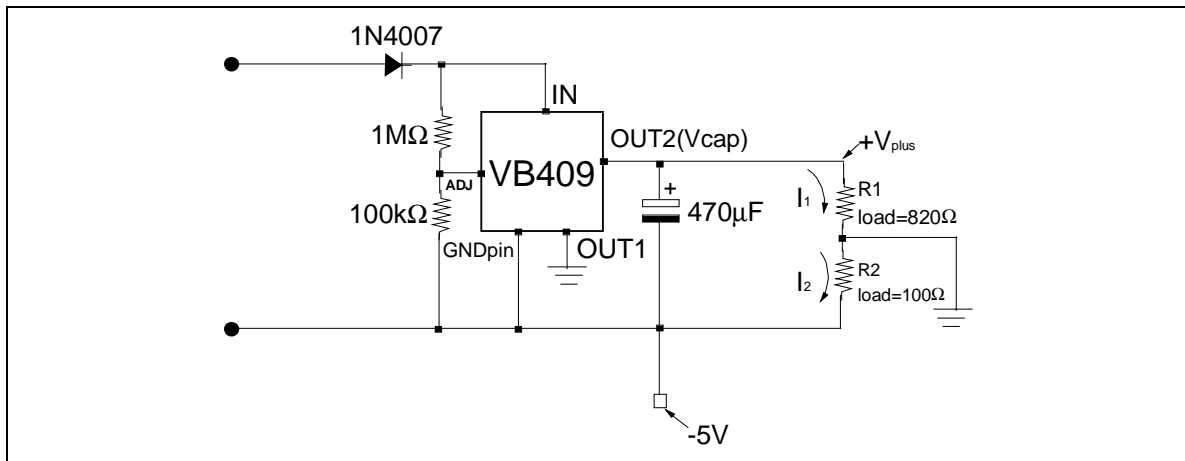

By indicating the currents flowing through R_1 and R_2 with I_1 and I_2 , respectively, the VB409 must provide a total current I_{tot} of I_1+I_2 . The I_{tot} current does not exceed the value of 80mA specified in the datasheet. With the data in figure 3:

$I_1 = V_{plus} / 820\text{Ohm} = 13\text{mA}$	$I_2 = 5V / 100\text{Ohm} = 50\text{mA}$	$I_{tot} = I_1 + I_2 = 63\text{mA}$
--	--	-------------------------------------

As well we can use the VB409 to supply, together with the -5V regulated voltage one +5V (also regulated) from output 2. To do this we propose the electrical scheme in figure 4. In order to have the +5V regulated voltage on R1, the +5V is generated from the +11V of output 2 by using the positive low voltage regulator L7805 or equivalent. By using this configuration the total current in the absolute value will be: $5V/820\text{Ohm}+5V/100\text{Ohm}=(6+50)\text{mA}=56\text{mA}$.

$I_1 = 5V / 820\text{Ohm} = 6\text{mA}$	$I_2 = 5V / 100\text{Ohm} = 50\text{mA}$	$I_{tot} = I_1 + I_2 = 56\text{mA}$
---	--	-------------------------------------

On the output pin of the L7805 it is suggested to connect a capacitor of $0.1\mu\text{F}$, in order to avoid self-oscillation:

Figure 4: $\pm 5V$ Application Schematic

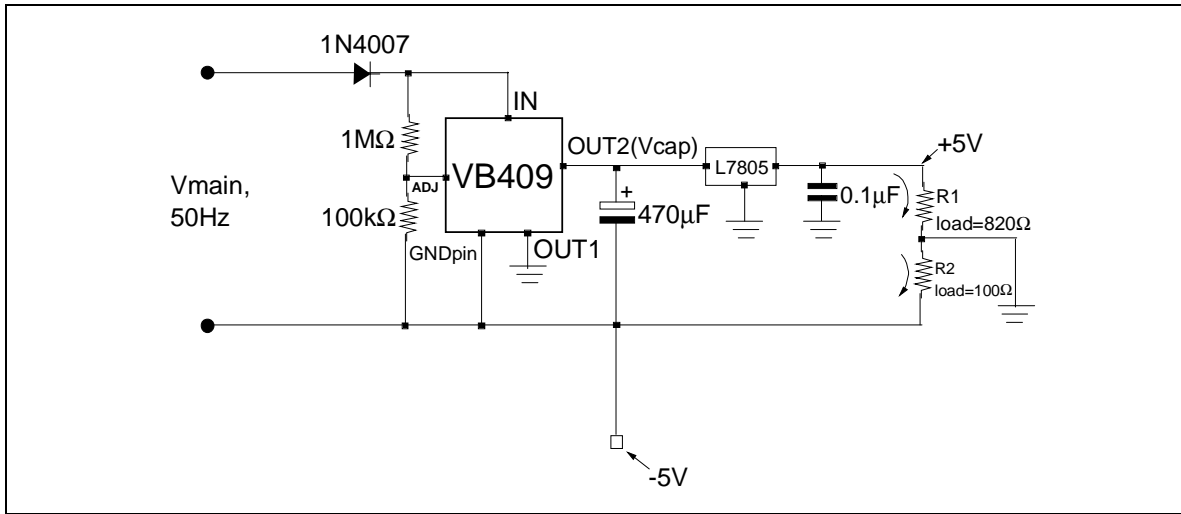

4. ADJUSTABLE NEGATIVE VOLTAGE REGULATOR.

If an adjustable negative output voltage is requested the schematic in figure 5 can be implemented. This schematic uses the negative adjustable voltage regulator LM337. In this way the negative output voltage may be adjusted from -2V to -5V. This device can be connected to the resistive load used in the former case.

Figure 5: Adjustable Negative Voltage Regulator

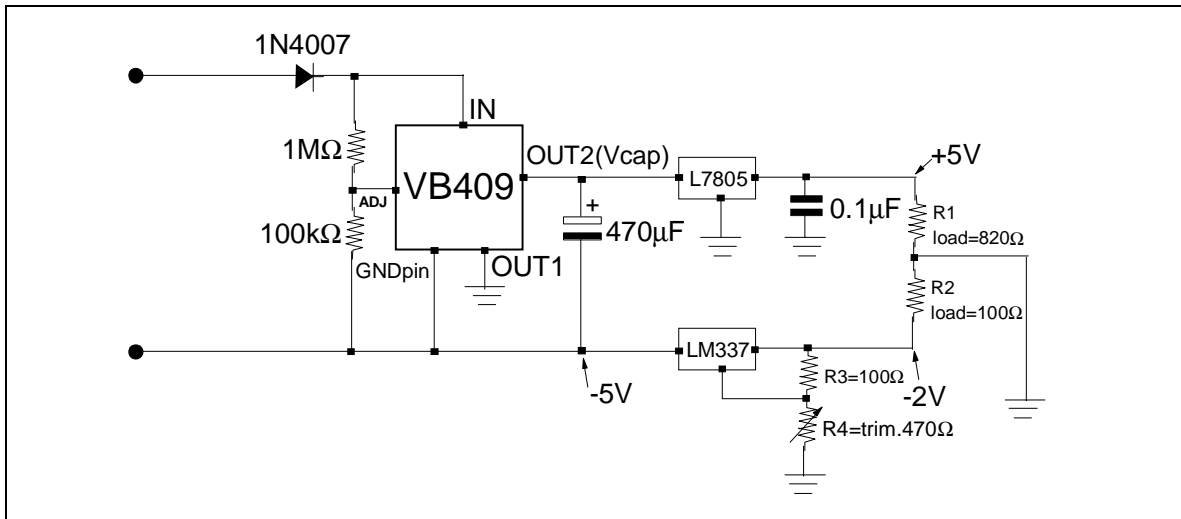

The LM337 is connected in the standard configuration with the resistor divider made of $R_3=100\Omega$ and $R_4=470\Omega$ (trimmer).

We connected three different loads:

- 1) $R_1=820\Omega$; $R_2=100\Omega$ (see the waveform in figure 6);
- 2) $R_1=470\Omega$; $R_2=100\Omega$ (see the waveform in figure 7);
- 3) $R_1=220\Omega$; $R_2=100\Omega$ (see the waveform in figure 8).

The currents (in absolute value) are in the table below:

$I_1 = V_{plus} / 820\Omega = 13\text{mA}$	$I_2 = 2\text{V} / 100\Omega = 20\text{mA}$	$I_{tot} = I_1 + I_2 = 33\text{mA}$
$I_1 = V_{plus} / 470\Omega = 23\text{mA}$	$I_2 = 2\text{V} / 100\Omega = 20\text{mA}$	$I_{tot} = I_1 + I_2 = 43\text{mA}$
$I_1 = V_{plus} / 220\Omega = 50\text{mA}$	$I_2 = 2\text{V} / 100\Omega = 20\text{mA}$	$I_{tot} = I_1 + I_2 = 70\text{mA}$

Figure 6: Output Waveforms with R1=820Ohm and R2=100Ohm (circuit in figure 5)

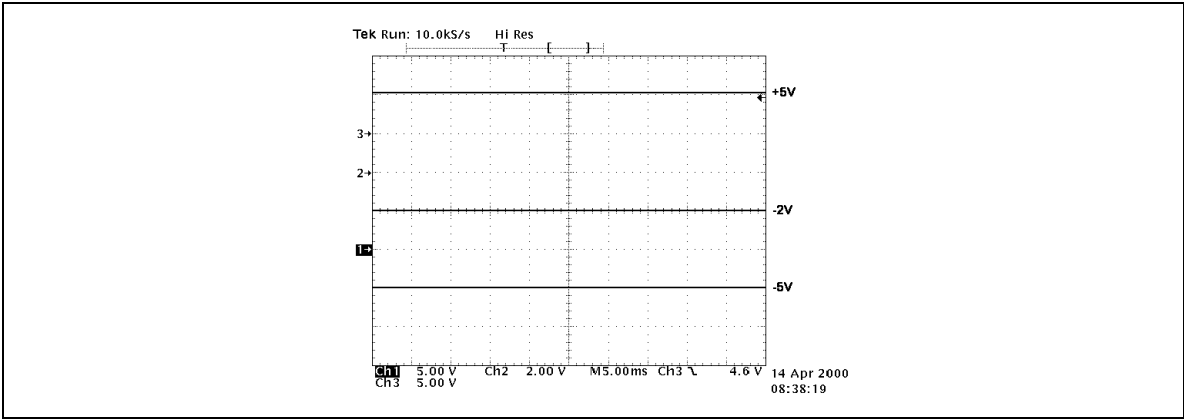

Figure 7: Output Waveforms with R1=470Ohm and R2=100Ohm (circuit in figure 5)

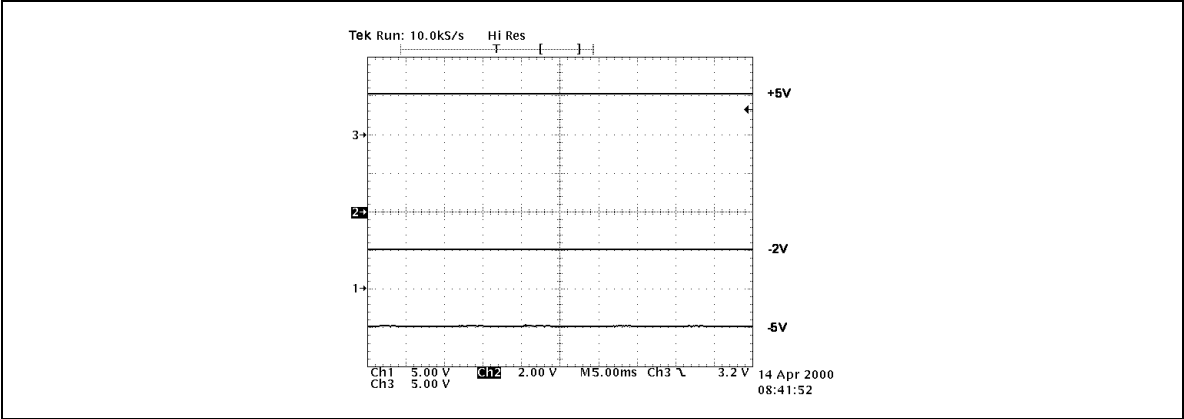
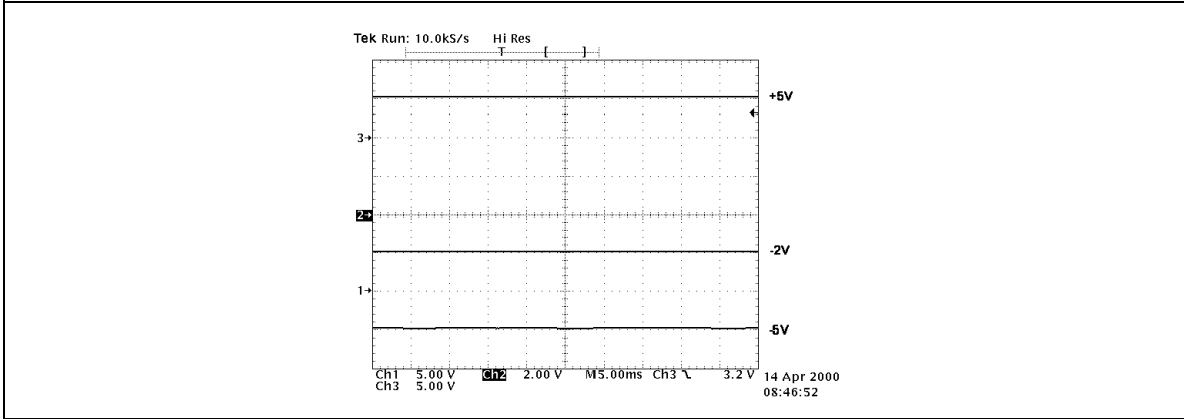

Figure 8: Output Waveforms with R1=220Ohm and R2=100Ohm (circuit in figure 5)



Information furnished is believed to be accurate and reliable. However, STMicroelectronics assumes no responsibility for the consequences of use of such information nor for any infringement of patents or other rights of third parties which may result from its use. No license is granted by implication or otherwise under any patent or patent rights of STMicroelectronics. Specification mentioned in this publication are subject to change without notice. This publication supersedes and replaces all information previously supplied. STMicroelectronics products are not authorized for use as critical components in life support devices or systems without express written approval of STMicroelectronics.

The ST logo is a trademark of STMicroelectronics

© 2000 STMicroelectronics - Printed in Italy - All rights reserved

STMicroelectronics GROUP OF COMPANIES

Australia - Brazil - China - Finland - France - Germany - Hong Kong - India - Italy - Japan - Malaysia - Malta - Morocco - Singapore - Spain - Sweden - Switzerland - United Kingdom - U.S.A.

<http://www.st.com>



LittleDiode supplies new, hard to find or obsolete electronic components and semiconductors all over the world.

With over two million different components listed you are sure to find the part you need.

Feel free to visit us today at our online store:

LittleDiode.com

Looking forward to providing you with the best possible service.