

## DRIVING THE VB409 WHEN A TRANSFORMER IS PRESENT

F. Macina - N. Aiello

### 1. ABSTRACT

The purpose of this application note is to provide some advice on how to handle oscillation and overvoltage conditions that occur when using a VB409 driven by a transformer. The results are also applicable when an inductance, in series with the input device, is present. After a short review of the transformer theory, simple tricks to solve these problems are presented.

### 2. TRANSFORMER THEORY.

A transformer consists of two or more coils magnetically coupled. Figure 1 shows a cross section of a transformer with two coils.

**Figure 1: Cross section of a transformer**

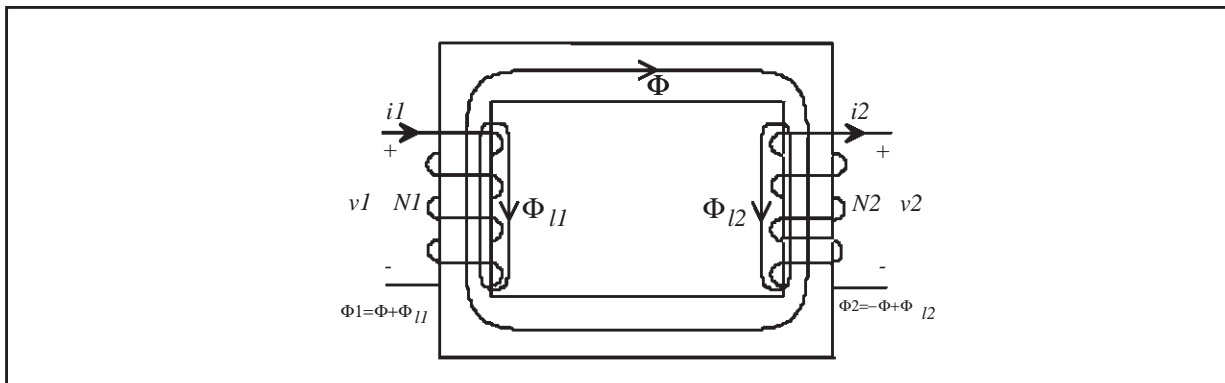

**Figure 2: B-H characteristic of the core**

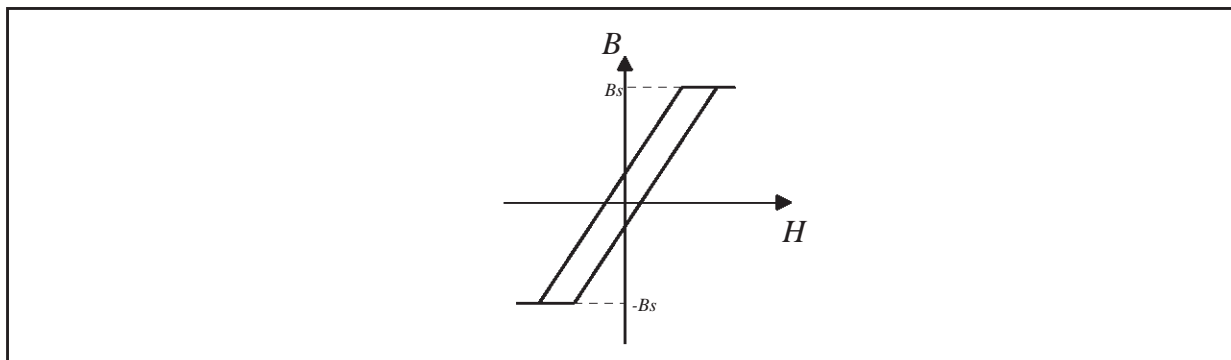

We assume that the transformer core has the B-H characteristic shown in figure 2 and that the  $B(t)$  is always less than  $B_s$ .

The total flux in coil 1 is given by: 
$$\phi_1 = \phi + \phi_{l1} \quad (1)$$

The total flux given in coil 2 is given by: 
$$\phi_2 = -\phi + \phi_{l2} \quad (2)$$

Where  $v_1$  and  $v_2$  are the respective leakage fluxes in coil 1 and 2. The flux  $v$ , linking the two coils, is given by:

$$\phi = \frac{N_1 i_1 - N_2 i_2}{\mathfrak{R}_c} = \frac{N_1 i_m}{\mathfrak{R}_c} \quad (3)$$

The leakage fluxes are given by: 
$$\phi_{l1} = \frac{N_1 i_1}{\mathfrak{R}_{l1}} \quad (4)$$

and 
$$\phi_{l2} = \frac{N_2 i_2}{\mathfrak{R}_{l2}} \quad (5)$$

Where  $\mathfrak{R}_c$  is the reluctance core  $\mathfrak{R}_{l1}$ ,  $\mathfrak{R}_{l2}$  are the reluctances of the leakage-flux path an  $i_m$  is the magnetizing current given by:

$$i_m = i_1 - \frac{N_2 i_2}{N_1} \quad (6)$$

Even in well designed transformers, the leakage fluxes are not negligible parts of the total coil fluxes. This results in leakage reluctances that must be accounted for in any transformer description.

The voltages  $v_1$  and  $v_2$  at the terminals of the transformer are:

$$v_1 = R_1 i_1 + N_1 \frac{d\phi_1}{dt} \quad (7)$$

$$v_2 = -R_2 i_2 - N_2 \frac{d\phi_2}{dt} \quad (8)$$

The resistances  $R_1$  and  $R_2$  represent the ohmic losses in the windings caused by the finite conductivity of the conductors. Using the previous equations we obtain:

$$v_1 = R_1 i_1 + \frac{(N_1)^2}{\mathfrak{R}_{l1}} \frac{di_1}{dt} + \frac{(N_1)^2}{\mathfrak{R}_c} \frac{di_m}{dt} \quad (9)$$

$$v_2 = -R_2 i_2 - \frac{(N_2)^2}{\mathfrak{R}_{l2}} \frac{di_2}{dt} + \frac{(N_2)^2}{\mathfrak{R}_c} \frac{di_m}{dt} \quad (10)$$

Equation 9 can be simplified defining the following quantities:

$$e_1 = \frac{(N_1)^2}{\mathfrak{R}_c} \frac{di_m}{dt} = L_m \frac{di_m}{dt} \quad (11)$$

Induced emf in coil1 magnetizing inductance: 
$$L_m = \frac{(N_1)^2}{\mathfrak{R}_c} \quad (12)$$

Leakage inductance in coil 1: 
$$L_{l1} = \frac{(N_1)^2}{\mathfrak{R}_{l1}} \quad (13)$$

Using these definitions in (9) yields:

$$v_1 = R_1 i_1 + L_{l1} \frac{di_1}{dt} + L_m \frac{di_m}{dt} = R_1 i_1 + L_{l1} \frac{di_1}{dt} + e_1 \quad (14)$$

If the third term on the right hand side of (10) is multiplied by  $N_1 / N_2$  and we define:

$$L_{l2} = \frac{(N_2)^2}{\mathfrak{R}_{l2}} \quad (15)$$

then (10) can be expressed as:

$$v_2 = -R_2 i_2 - L_{l2} \frac{di_2}{dt} + \frac{N_2}{N_1} e_1 = -R_2 i_2 - L_{l2} \frac{di_2}{dt} + e_2 \quad (16)$$

where  $e_2$  is the induced emf in coil 2.

Equations (14) and (16) form the basis of the transformer equivalent circuit shown below.  $\mathfrak{R}_m$  models the core losses.

**Figure 3: Transformer equivalent circuit**

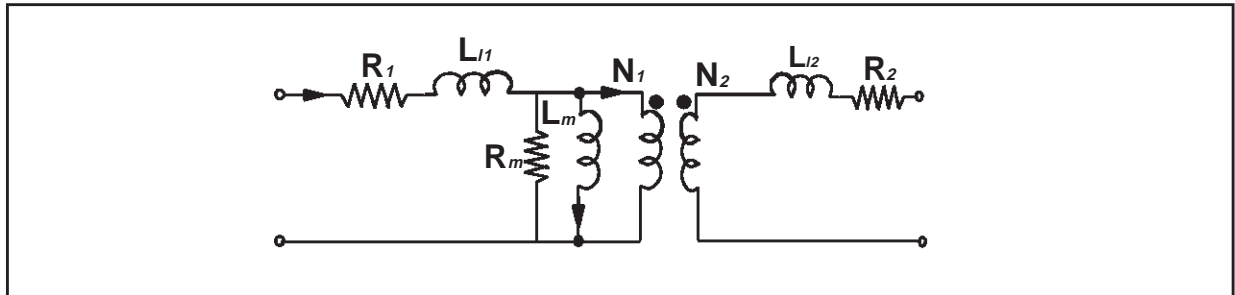

### 3. VB409 DRIVEN WITH A TRANSFORMER.

Even if the VB409 can be plugged directly on the mains, sometimes the application requires the presence of a transformer. In power electronics it must be designed for minimum leakage inductance because such inductance may be detrimental to the proper operation of the circuit. In case of switching devices, the leakage inductance can cause overvoltages at switch turn-off, and the VB409, as we will show later, is sensitive to this.

To better understand this problem, we will first consider the VB409 as an off-line power supply.

Figure 4: VB409 as an off-line power supply

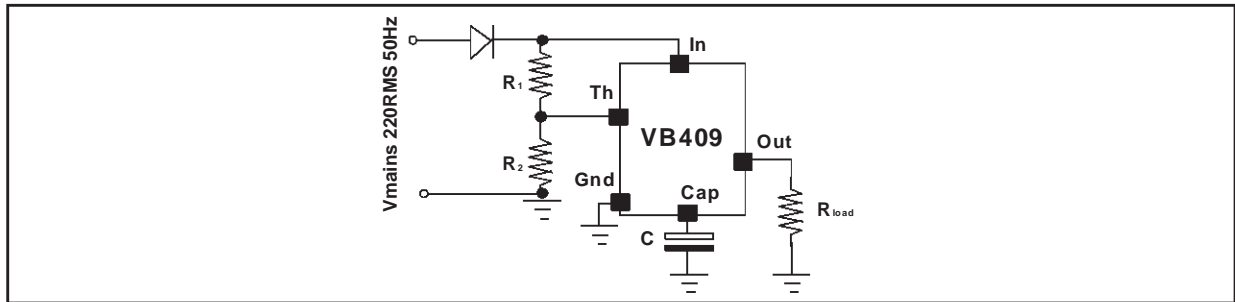

Figure 5: VB409 typical rising edge of the mains waveform in off-line applications

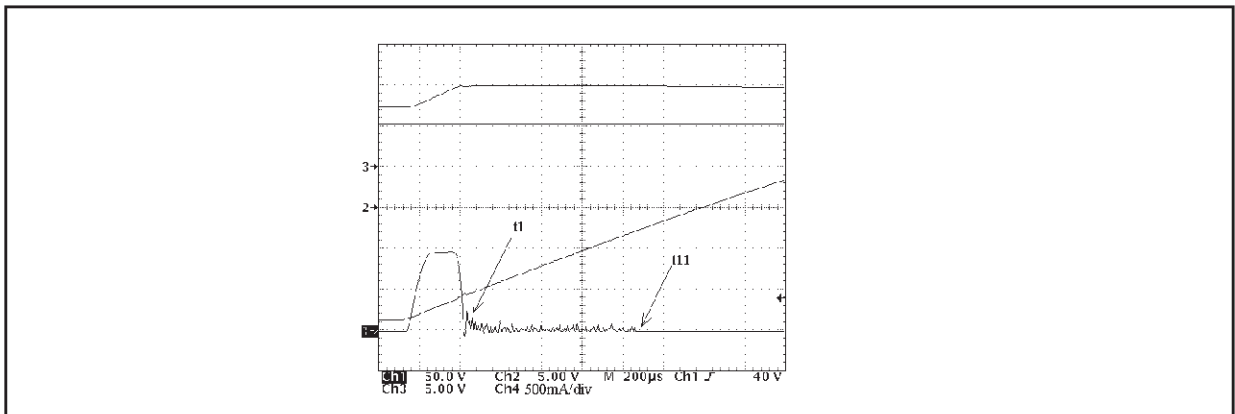
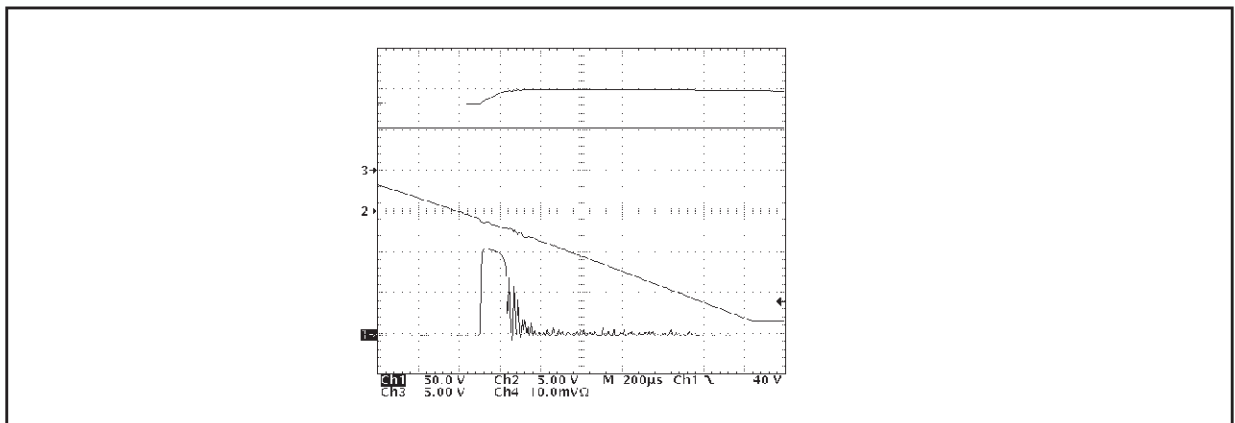
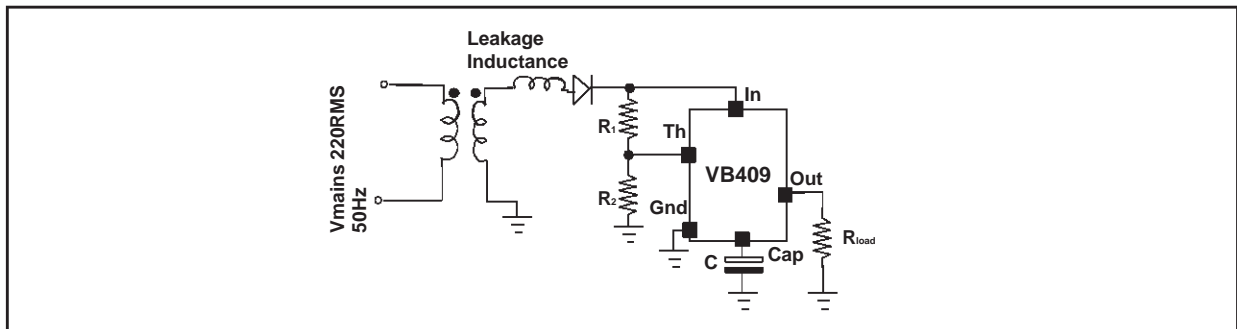

Figure 6: VB409 typical falling edge of the mains waveform in off-line applications



Referring to figure 5, the device input current (CH4), internally limited, charges the external electrolytic capacitor up to a maximum fixed voltage (CH2 is the voltage on the capacitor). As soon as this value has been reached (it happens in  $t_{11}$ ), the device input current oscillates around a value equal to the load current. This occurs until the mains voltage multiplied by the external resistor divider (i.e. the voltage on Th pin) equals an internal voltage reference, then the device is shut-off ( $t_1$ ). The same behavior takes place negative of the mains (in figure 5 the waveforms are reported).

Figure 7: VB409 driven with a transformer



Now we will consider the VB409 driven with a real transformer (figure 7). The other external components remain unchanged.

In this case, as it is possible to see looking at the figures 8 and 9, either when the voltage on the capacitor (CH2) reaches its maximum internal fixed value (it happens in  $t_{11}$ ) or when the input current reaches its internal limitation, the current flowing through the VB409 High Voltage stage (CH4) goes to zero. This is due to the very high gain of the maximum capacitor voltage control loop and on the pole introduced by the leakage inductance. Due to the energy stored in the transformer leakage inductance, the device turn off causes an input overvoltage whose amplitude and duration depends on the network parasitic elements. In figure 8 the first overvoltage has a value of about 550V. Once the energy has been dissipated, the capacitor voltage has decreased its value, therefore a new charging cycle starts and this repeats until the conduction time is exceeded. The same reasoning is valid during the falling edge of the mains (see figure 9).

Figure 8: VB409 typical rising edge of the mains waveform driven with a transformer

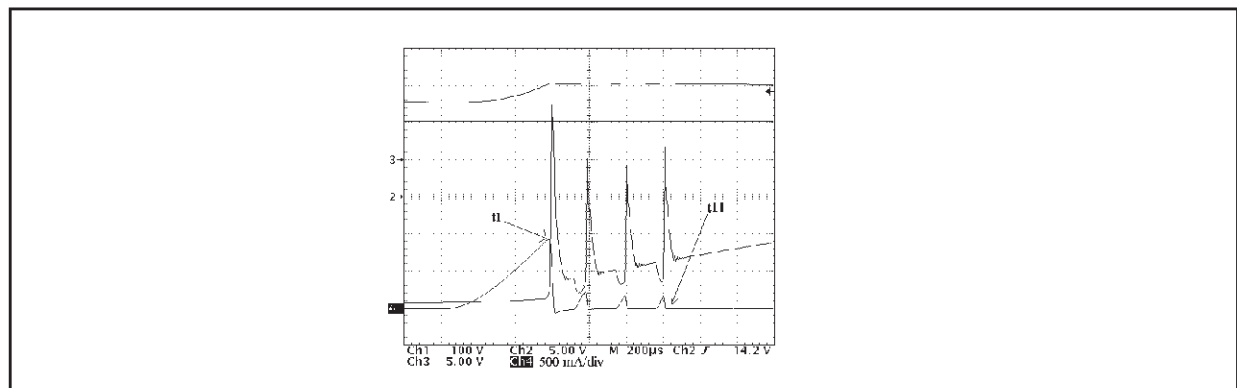
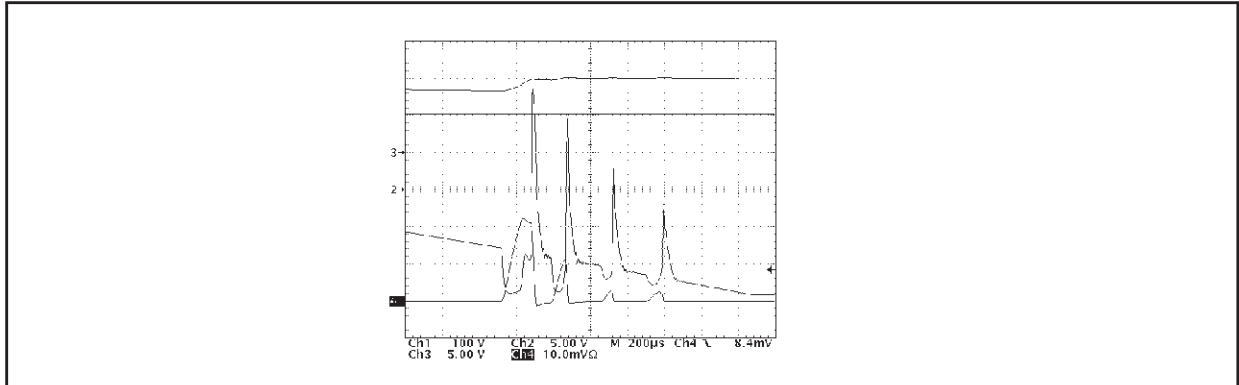

Figure 9: VB409 typical falling edge of the mains waveform driven with a transformer



The oscillation that occurs and the overvoltages are dangerous for the device itself and for the other circuit connected to the secondary of the transformer.

#### 4. SOLUTION PROPOSALS

Two solutions are presented below. Both solutions take advantage of the transformer parasitic inductance presence.

1) Due to the leakage inductance, during the conduction time the high voltage power stage will work in the saturation region (if the leakage inductance does not saturate). For this reason even if the conduction angle is chosen to be very short and the device output current is not low, the high voltage stage will supply current until the capacitor voltage will reach its clamp value. This happens because the device input voltage will always be below the value that causes the threshold to act. Thus the conduction time will be independent on the chosen external divider. In figure 10 and in figure 11 this conduction time modulation phenomena is shown. As it is possible to see, even if the external divider is the same in both situations, the conduction time, and also the output current, in figure 11 is greater than in figure 10.

Figure 10: Zoom-in of the rising edge of the mains with output current at 10mA

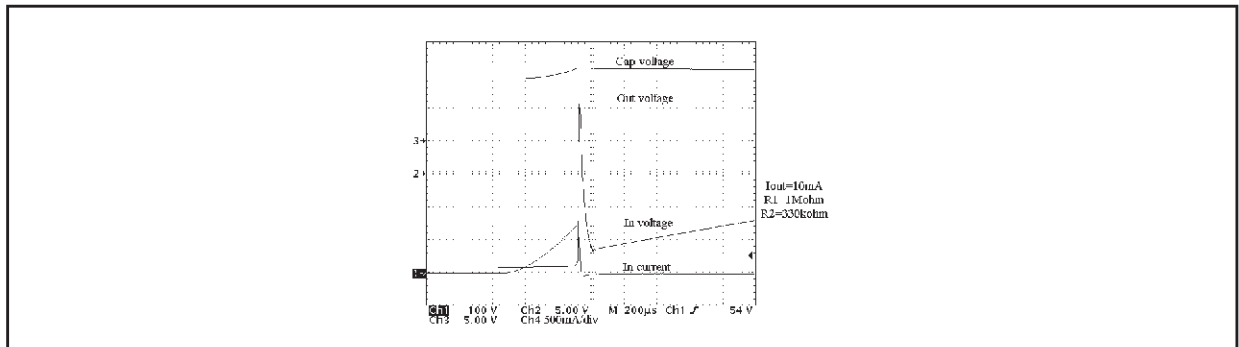
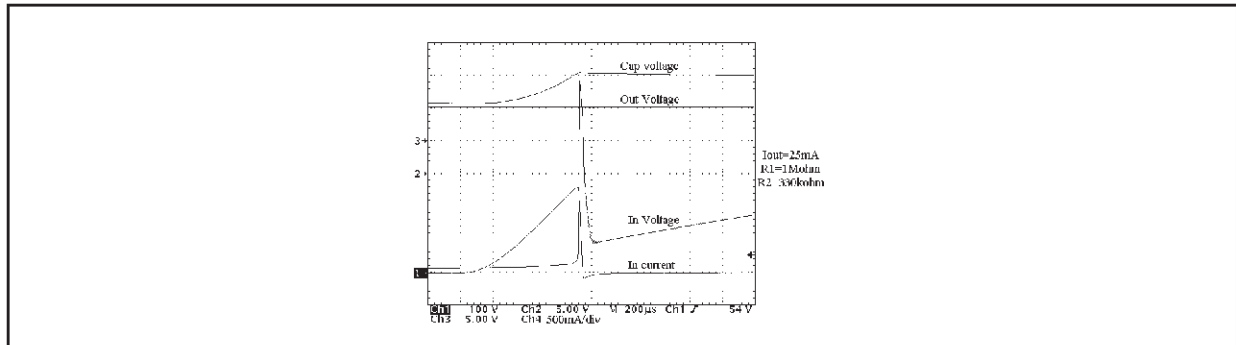

Figure 11: Zoom-in of the rising edge of the mains with output current at 25mA



The device will turn itself off only when the high voltage stage desaturates, that is when the capacitor voltage equals the maximum allowable value or when the input current reaches its limitation value. If the external divider has been chosen in order to have a low turn off voltage, once the VB409 has been shut-off and the energy stored in the inductance has been dissipated, the mains will get over this value confirming the device off state and eliminating any input voltage oscillation.

As a drawback, during the falling edge of the mains, if the conduction time is set too low, with great probability the capacitor will not be charged again to its maximum value (see the encircled cap voltage in figure 12). This could be a problem because during the half period of the non rectified mains, the capacitor must be able to supply the required charge to the load and the voltage on it must not fall below a minimum value that allows the VB409 low voltage stage to work properly. This problem would be overcome by using a Graetz's bridge. Thus in case of half rectification, a trade-off between a short conduction time and the need to recharge the capacitor is required.

Figure 12: The capacitor voltage is not symmetrical

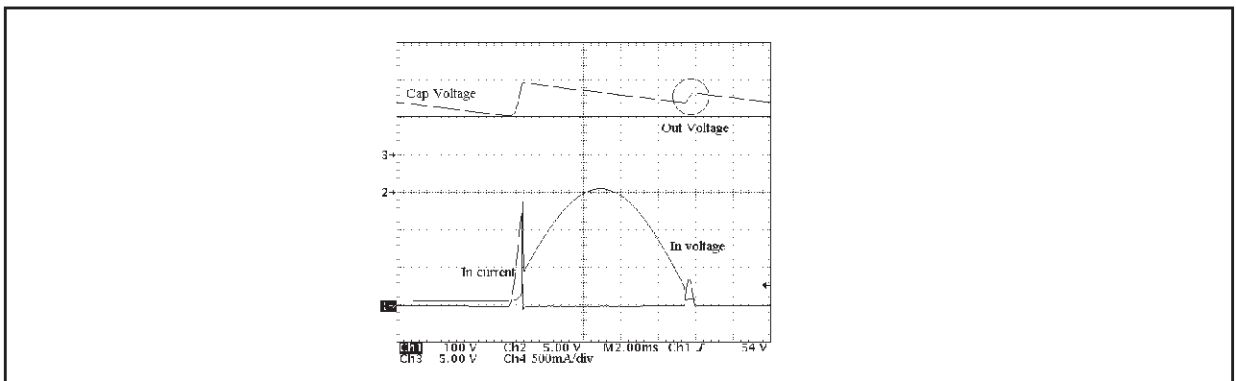

The experimental analysis has shown the external divider value  $R1=1M\Omega$  and  $R2=330k\Omega$  to be a good compromise.

Another drawback of this solution is that there is not a limit on the device input overvoltage at the turn-off. It will depend only on the energy stored in the leakage inductance and on the parasitic elements.

- 2) The previous solution has two problems:
  - a. The turn-off overvoltage is not limited.
  - b. The capacitor voltage could not be symmetrical.

To overcome these problems the solution shown in figure 13 can be used. The  $C_1$  capacitor, thanks to the energy stored in the leakage inductance, is charged after the first device turn off and the value of the input overvoltage can be calculated (thus limited) as follows:

$$\frac{1}{2}L_1(I^2)_{in} = \frac{1}{2}C_1(V^2)_{in} = V_{in} = I_{in}\sqrt{\frac{L_1}{C_1}} \quad (17)$$

where  $L_1$  is the leakage inductance.

Then this capacitor will discharge through the external divider. If it is chosen properly, that is the constant time  $(R_1+R_2)C_1$  is greater than the fixed conduction time but smaller than the time over which the device would turn on again (during the falling edge of the mains), the problem b. is also solved. The conduction time modulation phenomena is also valid with this solution.

**Figure 13: Solution 2 scheme**

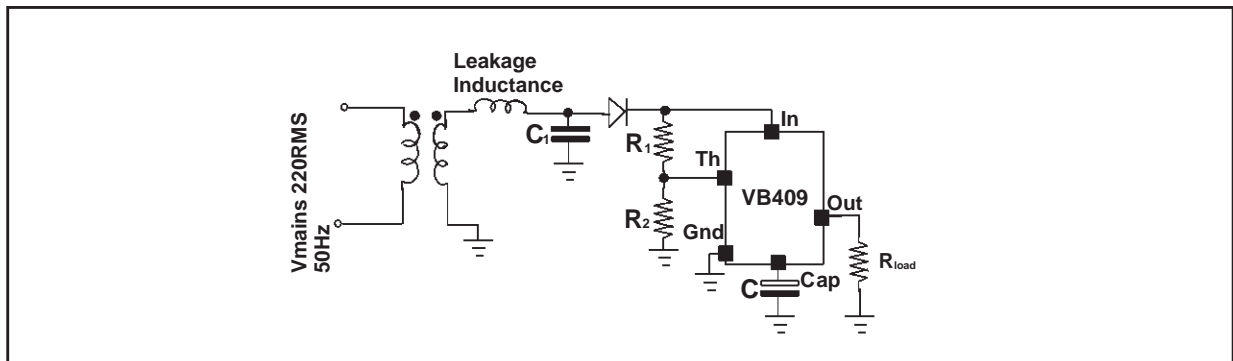

**Figure 14: VB409 typical waveform with the solution 2 proposal**

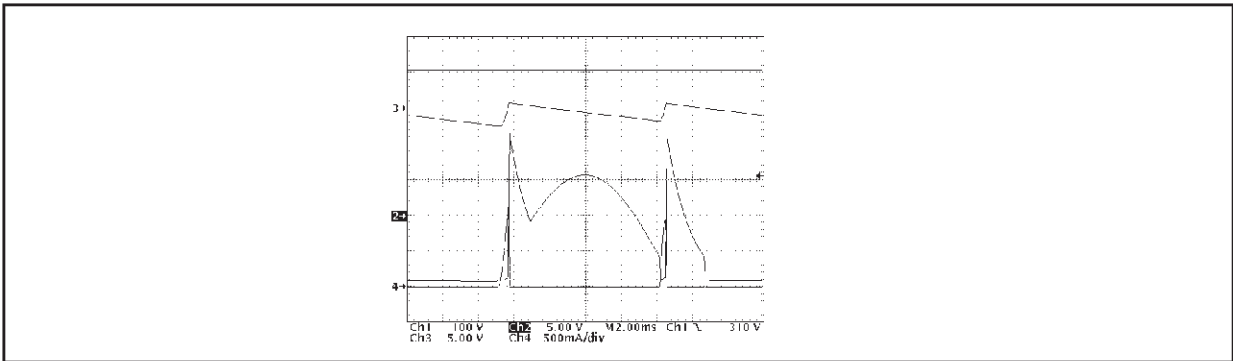

Figure 15: Zoom-in of the raising edge of the mains in figure 14

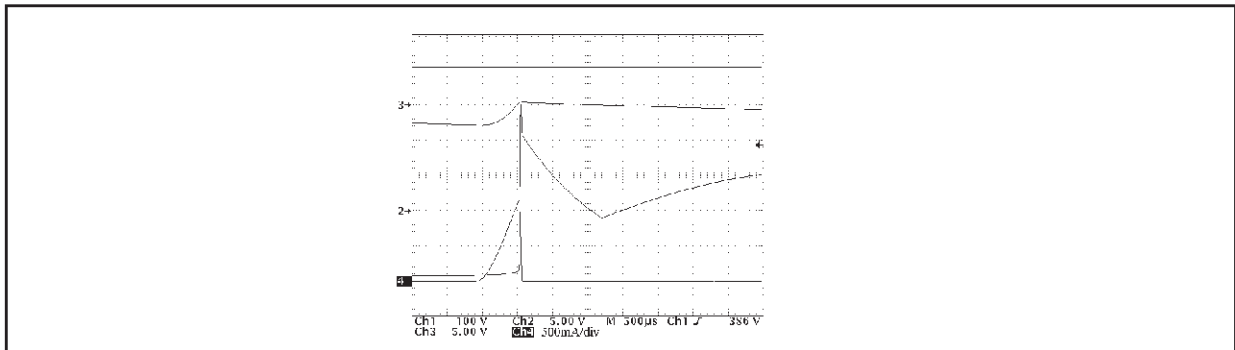
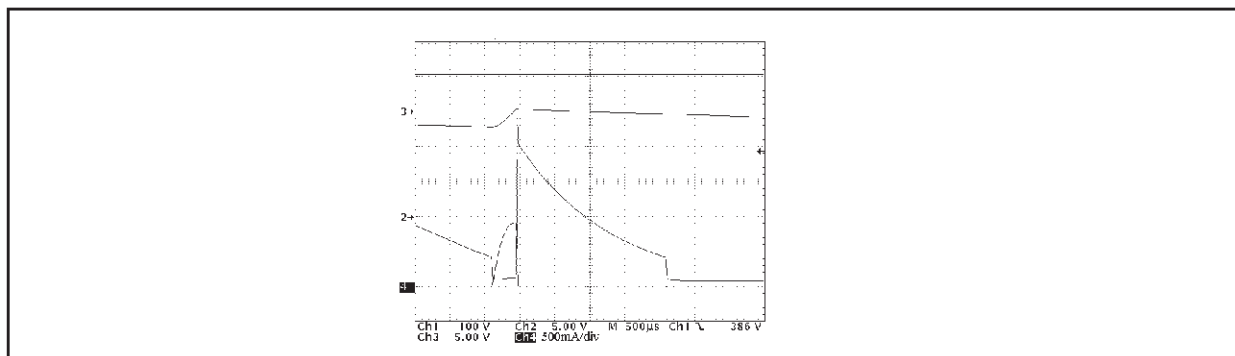

Figure 16: Zoom-in of the falling edge of the mains in figure 14



## 5. CONCLUSION

Two different schemes have been suggested in order to prevent oscillations and limiting the overvoltages that take place when a VB409 is driven with a transformer. The first solution has the advantage of being free of extra expenses, but the overvoltages are not limited and the capacitor could not charge itself enough, due to the short conduction time. The second solution limits the overvoltages and allows a conduction angle choice based on the output current required, but needs a high voltage capacitor.

Information furnished is believed to be accurate and reliable. However, STMicroelectronics assumes no responsibility for the consequences of use of such information nor for any infringement of patents or other rights of third parties which may result from its use. No license is granted by implication or otherwise under any patent or patent rights of STMicroelectronics. Specification mentioned in this publication are subject to change without notice. This publication supersedes and replaces all information previously supplied. STMicroelectronics products are not authorized for use as critical components in life support devices or systems without express written approval of STMicroelectronics.

The ST logo is a trademark of STMicroelectronics

© 2000 STMicroelectronics - Printed in Italy - All rights reserved

STMicroelectronics GROUP OF COMPANIES

Australia - Brazil - China - Finland - France - Germany - Hong Kong - India - Italy - Japan - Malaysia - Malta - Morocco - Singapore - Spain - Sweden - Switzerland - United Kingdom - U.S.A.

<http://www.st.com>



LittleDiode supplies new, hard to find or obsolete electronic components and semiconductors all over the world.

With over two million different components listed you are sure to find the part you need.

Feel free to visit us today at our online store:

[LittleDiode.com](http://LittleDiode.com)

Looking forward to providing you with the best possible service.