



Smart Battery Primer

By Carlos Martinez, Yossi Drori and Joe Ciancio, October 1999

INTRODUCTION

Rapid increases in product performance and features along with demands for longer operating life have driven designers of battery based electronics to consider significant changes in product design. These include using lower voltage components, turning off unused subsystems, managing applications software and developing "smarter" batteries and battery management. Designers of new battery systems need knowledge of many different, diverse and, in many cases, new fields. These fields range from battery chemistry and knowledge of how the battery operates; to system engineering and knowledge of how the various components interact; to product design and knowledge of how the user operates a particular device.

This application note is an introduction and overview of battery operation and terminology, and provides initial discussions of portable system and user design considerations. It is intended to provide some of the building blocks needed to understand the complex issues involved with battery and portable system design.

BATTERY BASICS

A battery is made up of one or more cells. These cells chemically store energy for use by the system. There are two types of cells. In **primary** cells the chemical reaction is not reversible, so they must be discarded (thrown away) when the chemicals are consumed. **Secondary** (or rechargeable) cells provide energy by transforming one chemical compound into another. These cells can be recharged by putting energy into the cell in order to convert the chemicals back to their original state.

Primary cells typically have higher capacity per size and weight and lower self-discharge rates¹ than rechargeable cells. However, using primary cells in systems with high energy demands or constant use is not economically practical. The need to replace these cells often is both inconvenient and expensive. Primary cells are best used

in low power or intermittent use applications, such as flashlights, radios, calculators and some low end PDAs. Primary cells today do not need built in intelligence. Their "throw away" nature means there is no need for fuel gauging, safety monitoring or recharge control circuits. As such, primary cells will not be discussed further in this application note.

Rechargeable cells have been around for a long time and use a variety of chemistries. The different characteristics of each chemistry make one more suited than the others in a particular application. Currently the most common types of rechargeable batteries are Sealed Lead-acid (SLA), Nickel-Cadmium (Ni-Cd,) Nickel Metal Hydride (NiMH) and Lithium Ion (Li+ or Li-Ion). Lead acid batteries are typically used in automotive applications or fixed installations because of their large size and weight. Newer Lithium technologies (such as Lithium Ion Polymer) are emerging, but they are not commercially available in quantity at this time. Lithium Polymer cells are expected to appear starting in the year 2000.

Terminology

Before getting into battery specifics, it is important to understand some of the terms used in defining and characterizing batteries.

• Electrode

Electrodes are the positive (cathode) and negative (anode) terminals of the cell. These are made of different materials, depending on the cell chemistry. The farther apart these materials are on the Standard Potentials Table, the higher the electronic potential of the oxidation or reduction chemical reactions and the higher the voltage produced by the cell.

• Electrolyte

The electrolyte is the chemical that separates the electrodes and provides a medium for conduction of the ions or intermediate compounds between the electrodes. The intermediate compounds or ions, result from chemical

1. See Terminology section.

reactions at the anode and cathode and carry the current through the battery. The electrolyte is usually some type of liquid or paste.

• Voltage

The voltage of a cell is based on the chemical composition of the electrodes and electronic potential that results from the oxidation or reduction potential of the chemical reactions at the electrodes. There are a number of terms used when discussing battery voltage.

- **Open circuit voltage** is the voltage on the cell with no load applied. This is usually a good approximation of the theoretical cell voltage.
- **Nominal voltage** is the typical operating voltage or rated voltage of a cell. For example, the nominal voltage of a NiCd cell is 1.25V.
- **Discharge Cut-off voltage** (or Under Voltage Limit) is specified as the voltage at the end of discharge and is also called the **end voltage**. This term is ambiguous. Sometimes it refers to the minimum operating voltage of the system, so the voltage is dependent on the application. Cut-off voltage can also apply to the voltage at which there is damage to the cell brought on by irreversible processes, so the voltage is determined by the cell. The diagram of Figure 1. uses the term **end voltage** to describe the voltage at which the cell can no longer supply voltage to the system and the term cut-off voltage to describe the voltage where damage to the cell occurs. Ideally the system should be designed with the end voltage as close as possible to the cut-off voltage. This allows maximum usable capacity of the battery.
- **Working voltage** is a term that refers to the operating voltage range of the cell under load. This voltage is between the open circuit voltage and the end voltage.
- **Charge Cut-off voltage** (or Over Voltage Limit) is specified as the voltage at the end of a charge cycle. The charge cut-off voltage is the level where all electrode chemicals have been converted with a minimum of gassing or overcharge reactions. This voltage is typically higher than the open circuit voltage of a fully charged cell.

For Li-Ion battery chemistries, charge and discharge cut-off voltages are very important and have very narrow tolerances between acceptable and unacceptable levels. Violating the charge and discharge cut-off voltage limits can result in cell damage or explosion.

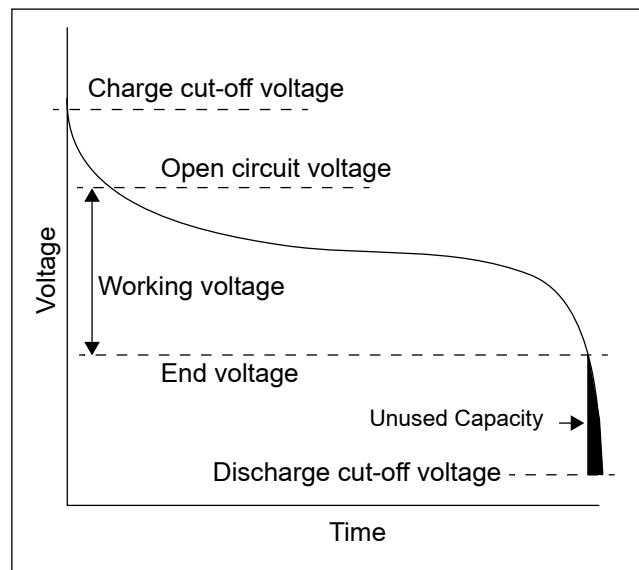

Figure 1. Voltage Definitions

• Internal Resistance

Internal resistance is an internal load within the cell. This load limits the maximum current that can flow through the battery. In an ideal battery, the internal resistance is zero. Internal resistance is made up of many small losses. These are largely related to the restriction in the migration of ions. The electrolyte material, through which the ions travel, and thickness of the electrolyte layer, can restrict ion movement. The choice of electrode materials, and how the battery is assembled, can increase internal resistance. Assembly factors include the method of connecting the electrodes to the battery terminals, the type and thickness of separator² layers, and the use and connection of various passive protection devices are attached to the cell³.

2. A separator is a porous layer that is placed between the electrolyte and the electrodes. In addition to providing separation, the pores of some newer film materials are designed to get smaller at temperatures above 120°C to restrict current flow and increase safety.

Since movement of the ions affects internal resistance, temperature can have an impact. For example, in cold conditions, ions move more slowly, raising the internal resistance. Since higher internal resistance results in lower peak current, some devices that have intermittent high current demands, such as a cell phone, may operate perfectly well at room temperature, but fails when making a call outside on a cold morning.

Internal resistance also increases as the battery is discharged. This explains how a nearly empty battery can operate a radio (with low peak current requirements), but fails when used in a radio controlled toy car (with high peak requirements). Finally, as a battery ages, internal resistance increases, so failures are possible with an old battery, even when fully charged.

- **Current**

Current is produced by electron flow in the electrode materials, ion flow in the electrolyte, and charge/transfer reactions at the interface of the electrode/electrolyte. Current flow is affected by internal resistance, temperature and size of the electrodes in the cell.

- **Current Capability**

Regardless of chemistry, current capability is a function of the surface area of the electrodes. The more surface area, the higher the current that can be obtained. This means that, using the same battery technology, a system needs physically larger batteries for higher current applications.

- **Capacity**

Cell capacity is essentially the amount of energy available to run a specific application until the cell reaches its end (cut-off) voltage. Capacity is usually expressed in milliampere-hours (mAh). A battery with a capacity of 1500mAh (at the one hour rate) can pass an electric current of 1.5A for 1 hour. However, the available capacity of a battery decreases when discharged at a higher current.

3. Protection devices are intended to "open circuit" when the temperature rises above a certain level.

A battery can be compared to a drum of water with a hole at the bottom. The water in the drum is comparable to the capacity and the size of the hole is the equivalent of surface area of the electrodes.

In an application, total cell capacity is not always the same as available cell capacity. If the cell is not fully charged by the system, there is less available capacity, even when total capacity remains the same. As the cell discharges, the system often shuts down prior to the end voltage to insure a "graceful" system power shut down. This also decreases available capacity. Systems that can utilize more of the total cell capacity increase their run time.

- **Run-Time**

This is a function of how long a battery can sustain the current needed for an application before reaching the end or cut-off voltage. Regardless of chemistry, a greater quantity of material in the anode or cathode the longer the battery can sustain the required current. Cells can be designed for longer run time by increasing the thickness of the electrodes, however a cell designed for longer run time will have lower current capability, unless the battery size increases.

- **Energy Density**

Energy density defines the amount of energy available in the battery. The measurement of energy density is based on volume (Watt-Hrs/Liter) or weight (Watt-Hrs/Kilogram). In portable applications, both volume and weight are critical. If two different types of batteries are about the same size and the same energy density, then the one that has less weight generally prevails. This can be seen in the recent migration from NiMH to Lithium in cellphones and PCs. Lithium and NiMH have about the same volumetric energy density, but Lithium has higher gravimetric energy density.

- **Discharge**

This is the conversion of chemical energy in a cell to electrical energy, with the electrical energy being dissipated into the load.

• **Discharge Rate**

The discharge rate is the amount of a current taken from a battery over a period of time. The discharge rate is often defined in terms of the battery’s capacity and is called the “C Rate Specification”.

The following expression is one way to refer to the discharge rate:

$$I = M \times C_n$$

Where I = discharge current,
 C_n = mAh rating of the cell at a specified C-rate (from the manufacturer)
 M = Cell discharge rate in the application. Specified as a multiple or fraction of C.

A battery rated at 5000mAh at the C/5 rate, when discharged at the C/5 rate (M=0.2) will provide 1000mA for 5 hours.

Since capacity changes based on the discharge rate, the battery above, when discharged at a C/10 rate of 500mA,

$$500\text{mA} = 0.1 \times 5000\text{mAh}$$

will run for more than 10 hours and provide more than the rated 5000mAh capacity. When discharged at its C rate of 5000mAh, the battery will run for less than a hour and deliver less than the rated 5000mAh of capacity. See Figure 2.

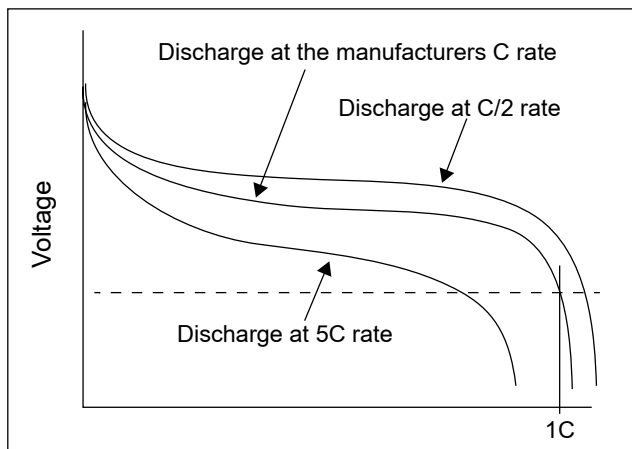

Figure 2. Discharge at different rates

Cells operating at very high discharge rates, such as 10C, may behave very differently from nominally similar cells because of design or construction difference. For example, cells that were designed for long life at low current drain are designed with thick anodes and cathodes, whereas cells intended for bursts of high current are designed to maximize the electrode surface area.

• **Depth of Discharge**

The degree of discharge is expressed as a percentage. When the battery reaches the end voltage condition, the battery has reached 100% depth of discharge. The term “deep discharge” generally refers to withdrawal of at least 80% of the rated capacity of the cell. Increasing the depth of discharge decreases the maximum number of charge/discharge cycles possible from the cell. See Figure 3.

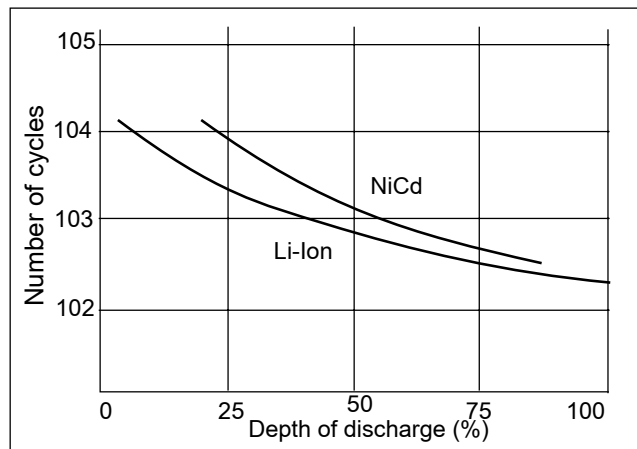

Figure 3. Cycle life vs. depth of discharge

• **Self Discharge**

As a battery sits on the shelf, or is connected to a host device for extended periods without being charged nor discharged, a certain amount of electric energy is lost internally, reducing the capacity of the battery. This loss accelerates with heat. This can be a very important consideration when choosing a battery technology. An alkaline primary cell is good for flashlights, because it has very little self discharge. A NiCd battery, however, is very poor for this application (without constant charging), because it has a self discharge of 15% per month.

• Cycle

A cycle refers to the process of discharging, then charging a cell. There are different measures of a cycle. When the manufacturer rates a cell for cycle life, a cycle refers to fully discharging the cell to the end voltage then fully charging to the charge cut-off voltage. In fuel gauging applications, and during typical usage, however, one cycle can also refer to charging and discharging the battery at levels between fully charged and fully discharged.

Comparing Chemistries

Today's high performance portable products are migrating to Lithium Ion type batteries, because of their characteristics of high capacity per weight and volume. However, to get a perspective on the various battery chemistries, the discussion below highlights some characteristics of the main types of rechargeable batteries.

NICKEL CADMIUM (NICD)

Nickel Cadmium batteries contain a positive electrode made of nickel hydroxide, a negative terminal made with a cadmium compound and an electrolyte of potassium hydroxide. The chemical reaction at the anode of the NiCd battery is:

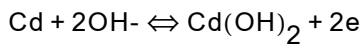

(discharge goes left to right, charge goes right to left)

This reaction has an electric potential of -0.81V. The chemical reaction at the cathode of the NiCd battery is:

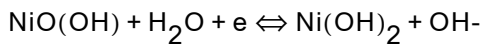

(discharge goes left to right, charge goes right to left)

This reaction has an electric potential of 0.52V. This gives a theoretical voltage for a NiCd cell of:

$$NiCd = Cathode - Anode = (0.52) - (-0.81) = 1.33V$$

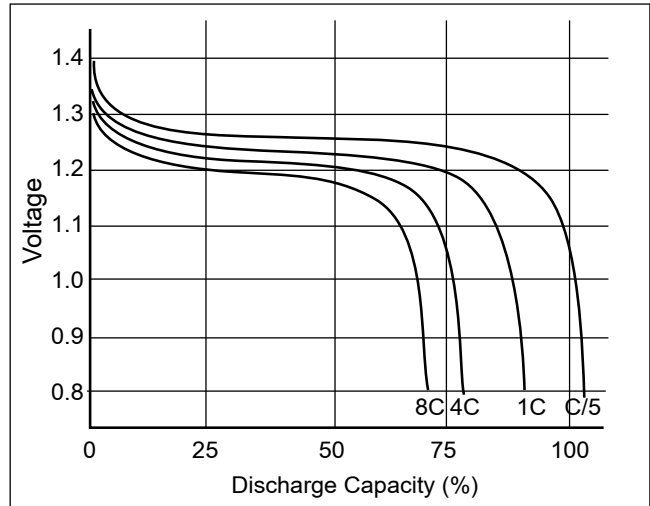

Figure 4. Typical NiCd discharge curves at different rates at 20°C.

NiCd batteries are typically recharged using a constant current. Most NiCd batteries can be safely charged without electronic control at low current rates of C/10 to C/3. Higher rates of charge, required for fast recharge applications, must use electronics to detect when the charge cycle is complete. Some mechanisms used when charging NiCd batteries to detect the end of charge are listed below.

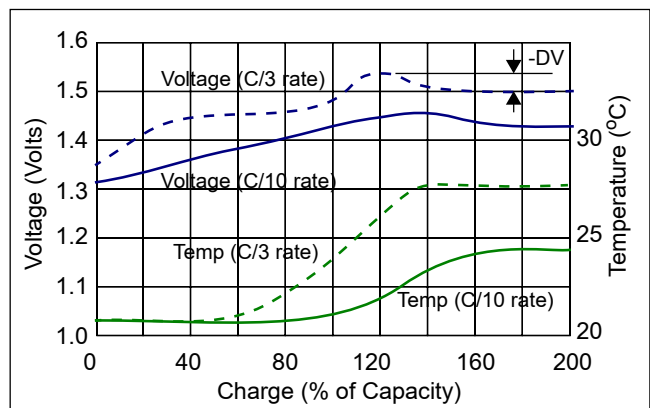

Figure 5. NiCd Charge Profile

- Standard method. This technique uses only a resistor between a DC power supply and the battery. It uses no other electronics. The battery is then charged at a low C/10 rate. This method limits the temperature rise. Circuitry terminates the charge when the battery is charged to 140-150% charge input. The limitation of this method is that it has a very slow recharge time.
- Timer Control. A timer is used to reduce current from a higher rate to a lower “trickle charge” state (see below). This technique is not used where the battery is frequently charged without prior deep discharging since this can result in overcharging the battery. Without periodic deep discharge, the NiCd battery develops a reversible condition, known as “voltage depression” or “memory effect”, where the delivered capacity gradually decreases. Using a timer that is fixed at the recharge time of a new cell can overcharge a cell experiencing a memory effect. As such, the timer technique would normally also include a thermal cut-off control.
- Temperature detection. This circuit uses a sensor to detect the temperature rise of the cell and terminate the charge. This method can be adversely affected by ambient temperature and may result in under charge conditions when charged in high ambient temperature environments or over charge in low ambient temperature environments.
- Negative delta V. This is one of the preferred methods of determining end of charge for NiCd batteries, because it is independent of ambient temperature. As the battery is charged the voltage rises. As the battery passes full charge, however, the voltage starts to decline. This negative change in the battery voltage determines the end of charge. A negative voltage of 10-20mV is typically used for the negative voltage change. Charging rates must be greater than C/2 for this technique to be useful, since the delta V is otherwise too low to detect.
- Trickle or Float charge. Trickle charging refers to a very small amount of current applied to the battery. This technique is used when a battery is continuously

connected to a charger or as a supplementary charge at the end of a fast charge cycle. Trickle charge rates range from 0.02 to 0.05C, depending on the frequency and depth of discharge.

Of the three main rechargeable chemistries for hand-held applications, NiCd is the oldest and has the least capacity per size and weight. To avoid memory conditions, NiCd batteries are often fully discharged prior to charging. These factors make NiCd unattractive for small, high performance light weight portable products. Because of their very low internal resistance, however, they are still the best choice for power tools or other high peak current applications. NiCd batteries do not need a great deal of electronics built-in, though there is increasing use of electronics in NiCd battery packs for better measurements of remaining energy.

NICKEL METAL HYDRIDE (NiMH)

Using a chemistry similar to NiCd, Nickel Metal Hydride uses nickel hydroxide for the positive terminal, but uses a hydrogen absorbing alloy for the negative terminal. Like the NiCd battery, NiMH uses a potassium hydroxide electrolyte. The chemical reaction at the anode of the NiMH battery is:

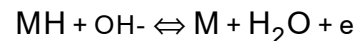

(discharge goes left to right, charge goes right to left)

This reaction has an electric potential of -0.83V. The chemical reaction at the cathode of the NiCd battery is (discharge goes left to right):

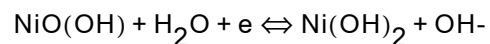

(discharge goes left to right, charge goes right to left)

This reaction has an electric potential of 0.52V.

$$\text{NiMH} = \text{Cathode} - \text{Anode} = (0.52) - (-0.83) = 1.35\text{V}$$

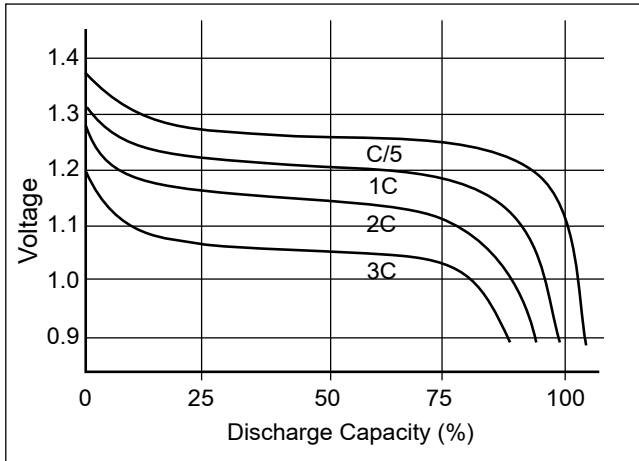

Figure 6. Typical NiMH discharge curves at different rates at 20°C.

NiMH batteries are charged using techniques similar to NiCd batteries. NiMH, however, requires more monitoring due to greater sensitivity to overcharging. A NiMH battery is often charged with a constant current, with the current limited to some low rate to avoid excessive temperature rise. Mechanisms for terminating the charge and techniques to allow faster charging are shown below.

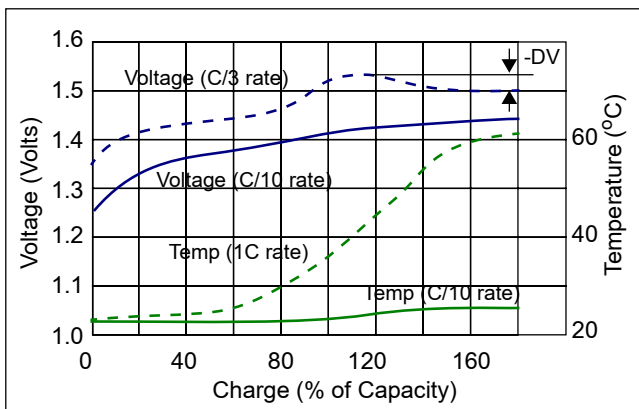

Figure 7. NiMH Charge Profile

- **Timer Control.** This technique is the same as for NiCd type cells and is typically used only at low charge rates, because the charge state of the battery cannot be determined prior to charging. It is most often used only as a way to complete the recharge after using some other charge technique.
- **Negative delta V.** While this is often used for NiCd batteries it may not be effective for NiMH types. With NiMH, the voltage peak is not as prominent and may not exist at less than C/3 charge rates, particularly at higher temperatures. The voltage monitor circuit must detect a 10mV decrease in voltage to determine the end of charge, but it must not be so sensitive that noise or other factors causes a premature end of charge.
- **Voltage Plateau.** This method is similar to negative delta V, but the circuitry looks at when the voltage peaks and the slope of the voltage curve is zero. The risk of overcharge is less than with negative delta V and can use a trickle charge to complete a full charge operation.
- **Temperature detection.** This circuit uses a sensor to detect the temperature rise of the cell and terminate the charge. This method is affected by ambient temperature, so may result in an undercharged battery when charged in a warm environment. This technique is often used with other methods.
- **Delta temperature cut-off.** This method measures the battery rise above the ambient temperature and cuts off when it exceeds a threshold. This threshold level varies when it exceeds a threshold. This threshold level varies based on cell size, number of cells in the pack, and heat capacity of the battery. The cut-off level is determined separately for each battery pack design.
- **Rate of temperature increase.** This technique eliminates the effects of ambient temperature. In this method, the change in temperature over time is monitored and charge is terminated when a particular incremental temperature rise is reached. This is the preferred method of detecting end of charge for NiMH, since it provides a long cycle life for the battery.

Using NiMH cells results in a battery pack with more capacity in a smaller package with less weight than NiCd, making them better suited for portable applications. They are also more environmentally friendly, since they contain no Cadmium. However NiMH batteries do not supply the peak current that NiCd offers, nor do they provide the gravimetric energy density of Lithium Ion batteries. NiMH may displace NiCd because of environmental concerns. This is already happening in Europe. However, NiMH batteries must overcome their peak current limitations or they will not totally displace NiCd for power tools or other high current applications. In many light weight portable applications NiMH is already being replaced by Lithium Ion. So the future of NiMH is not certain. At the present time, NiMH offers a more environmentally friendly battery than NiCd at a lower cost than Lithium Ion. Electronics are being added to NiMH batteries to better monitor the charge state to give the user more information about remaining capacity.

LITHIUM ION

There is a rapid move to Lithium Ion (Li-Ion or Li+) batteries as portable products need increased performance along with smaller size and less weight. Li-ion batteries today provide the highest volumetric and gravimetric capacity of any other production rechargeable battery, though the cost is higher.

Lithium Ion batteries are physically constructed with three main layers. These are the positive electrode plate, the negative electrode plate and a separator. The basic operation of a Lithium-Ion battery consists of the movement of only a Lithium ion from one electrode to the other. The anode contains a compound that receives the ions during discharge and gives up the ions during charge. The cathode operates in reverse, giving up the ions during discharge and receiving them during charge.

Lithium Ion battery chemistries are relatively new and are evolving rapidly. New compounds are being developed to improve the capacity and reduce the size of the cell. To gain market share and improve the performance of their cells over the competition, different manufacturers have developed their own combinations of chemical compounds for the anode and cathode. As more is

learned and as new compounds are developed more changes in Li-Ion chemistries are expected. These changes will also be impacted by required capacity increases and declining costs.

Since each manufacturer strives to develop a better battery they use different combinations of chemicals for the electrodes. The positive electrode uses compounds such as lithium cobalt oxide, lithium nickel oxide or lithium manganese oxide. The negative electrode typically uses graphite or amorphous carbon (coke). However other, more exotic compounds have been proposed. Since each combination of compounds has different electrical potentials, the operating voltages and charge/discharge characteristics can differ from battery to battery. Further unknowns arise with Lithium-Ion Polymer batteries, which substitute a polymer compound for the liquid electrolyte in a normal Li-Ion cell.

The overall chemical reaction of a Li-ion battery is quite complex. Using Lithium Cobalt oxide The overall reaction (including both anode and cathode) is:

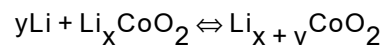

(discharge goes left to right, charge goes right to left)

This reaction has an electric potential of 4.2-4.3V.

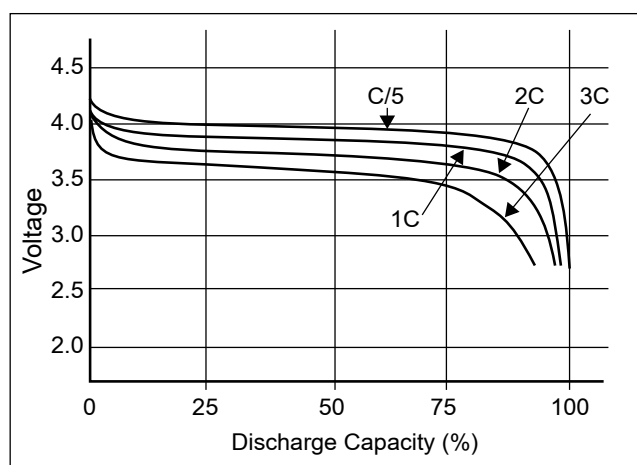

Figure 8. Typical C/LiCoO₂ Li-ion discharge curves at different rates at 20°C.

The mechanisms for charging Li-ion batteries are different than those for charging Nickel based batteries. Li-ion uses a constant current, constant voltage charge mechanism. The charger applies a constant current to the battery until the voltage reaches the desired voltage, then holds the voltage constant as the current declines. See Figure 9. New pulse charge techniques are being explored. These chargers apply pulses of fixed current at a variable rate or duty cycle. When the current is shut off circuits monitor the voltage on the cells in the pack. As the cell voltages get close to the charge cutoff voltage, the pulse rate (or duty cycle) declines, though the charge current remains constant. Pulse charging circuits promise to reduce charge time, increase safety, improve cell balancing techniques and increase the amount of charge on the cells. However, more battery research is required before this charging technique is approved by the battery manufacturers.

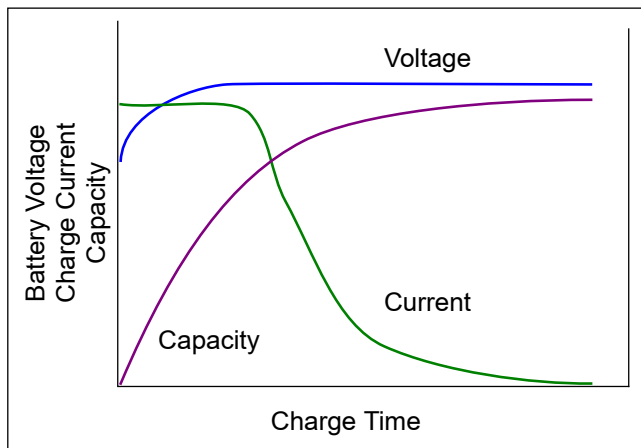

Figure 9. Li-ion charge characteristics

Li-ion batteries require circuitry to carefully monitor over voltage and under voltage conditions, since these can lead to battery failure or capacity reductions. The circuits must also monitor over current or short current conditions since these can lead to temperature increases in the cell that may also result in catastrophic failures. As a backup, most Li-ion battery packs monitor internal temperature and shut the pack down in the event of a significant temperature increase.

The wide range of electrode materials complicates the pack design. Since Lithium Ion batteries are more volatile than either NiCd or NiMH, electronics are required in each pack to insure that the operation does not exceed specified limits. The electronics must be able to handle all varieties of Li-Ion batteries to provide maximum safety, battery cycle life and run time. See Table 9.

Table 1. Battery Chemistry Comparison

Battery Parameter	NiCd	NiMH	Li-Ion
Energy Density (Wh/Kg)	50-85	75-100	110-130
Energy Density (Wh/L)	150-180	220-300	270-320
Operating Voltage	1.2	1.2	3.6
Open Circuit Voltage	1.3	1.3	4.1-4.3
End of Voltage	0.9	0.9	2.0-2.3
Average self discharge (per mo.)	15-20%	20-30%	6-10%
Internal Resistance	3.5-300mW	19-800mW	300-500mW
Fast charge current	>1C	>1C	1C
Charge method	constant current	constant current	constant current/constant voltage
End of charge	Peak Volt Detect (PVD)	PVD or DT/Dt	Minimum Current
Charge/Discharge cycles	1500	500	500
Operating Temp Range	-20oC to 60oC	0oC to 60oC	-20oC to 60oC
Cost	Low	Med	High

Notebook PC Application Example

The portable computer today exemplifies the need for higher capacity batteries and demonstrates the trend of increased intelligence in power management. In 1996, the typical portable computer consumed about 17 watts and generated internal temperatures up to 34oC. Through 1996 and 1997 CPU performance increased, LCD screens became larger, and disk drives packed in more bits. As a result, power consumption and temperature increased. It was obvious in 1997 that batteries would not be capable of providing the necessary power and the system heat generated would result in customer

discomfort or injury. Without system power management, Intel estimated that by 1999 PC power consumption would more than double, to 35W, and generate case temperatures of over 50°C (122°F). As a result, Intel, Microsoft and others created portable power standards, which defined how to design the hardware, the operating system and software applications to better manage the power consumption. Additionally, the goal was to maintain or increase battery life and reduce the physical dimensions of the PC, while keeping the power dissipation below a specified maximum of 25 watts.

There are several ways to address increased system performance in smaller packages with lower operating temperature and longer battery life. Some of these are:

- **Turning off sub-systems that are not being used.**
This takes intelligence in the operating system as well as in the hardware architecture and peripherals.
- **Turning off software that is not needed.**
This takes intelligence in the application software as well as an understanding of user preferences and habits. For example, text editing programs do not need to operate at maximum processor performance unless graphics are added or the document gets larger.
- **Reducing the operating voltage:**
The power used in a system drops as the square of the voltage on system components.
- **Battery Selection and Intelligence:**
Using a small, lightweight battery with more capacity coupled with electronics increases overall energy to the system. The electronics provides more charge to the battery (while maintaining safe conditions) with more accurate voltage and current sensing. The electronics also provide better monitoring of remaining capacity so the system can operate closer to the battery end of charge condition. Many systems today stop operating with 30% or more of the battery capacity remaining, because of uncertainty in the fuel gauge and the desire for a “graceful” system power down. Electronics in the battery pack can also speed the charge cycle by allowing new fast charge techniques while maintaining battery safety. Faster charging means more operating time per day.

Battery Pack Configurations

Battery packs consist of 1 or more cells. Serial connections provide higher voltage, while parallel connections provide higher current capacity⁴. Some packs utilize combinations of serial and parallel cells. Typically there is a trade-off between available space, capacity (run-time) and required voltage.

A battery powered design should actually start with the consideration of battery space, weight and capacity. Knowing this and having a knowledge of the operating voltage of the various system components plus total system power requirements, the designer determines the cell configuration. Depending on the available space and system power consumption, the designer then specifies the level of power management for the system.

A typical notebook PC might use four series combinations of 2 parallel Li-Ion cells. This is termed a 4S-2P pack. If each cell is nominally 3.6V with 1350mAh capacity, then the overall pack provides 2700mAh at 14.4V.

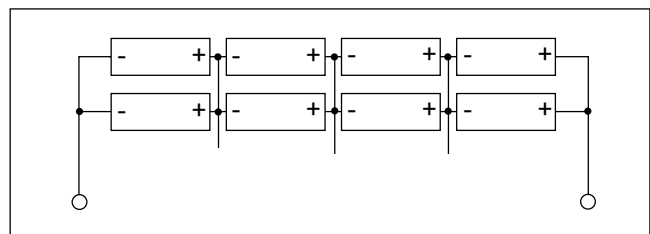

Figure 10. 4S-2P arrangement of cells in a battery

Lithium-Ion Cell Limitations

As discussed earlier, Lithium Ion batteries are key to achieving performance in portable devices in the near future. They have excellent volumetric and gravimetric energy density. However, they also present some serious design and safety issues that must be solved.

Lithium Ion batteries need special safety circuits in every battery pack to monitor over-charge, under-charge and short circuit conditions. If these conditions occur, the

4. Higher capacity might be available in a single cell instead of putting devices in parallel, however the thickness of the cell would increase, resulting in increased height of the pack. In some applications, such as a PC, there are more limitations on pack height than on length and width.

battery pack must be “shut down.” In the worst case, over charging lithium Ion batteries can result in sudden, automatic, and rapid disassembly (explosion). In the best case, overcharging lithium Ion batteries can result in damage to the cells, reducing capacity and cycle life.

The battery pack safety circuit limits the maximum charge voltage to prevent unsafe conditions. However, an over-voltage limit set too low significantly reduces run time as capacity is given up and an over-voltage limit set too high can result in damage to the cells. Similarly, the under voltage limit must be set accurately, since over discharging the Li-Ion battery results in chemical changes that are irreversible, reducing the capacity and cycle life, while stopping discharge too soon leaves usable capacity in the battery. The safety unit must, therefore, have the correct over-voltage and under-voltage limits and these limits must be accurate to a very narrow range. Because of the critical nature of the safety circuits in a battery pack, some systems employ redundant or backup mechanisms for shutting down the battery pack and switching the load off from the cells.

Lithium ion batteries need very precise electronic monitors and safety circuits built into the battery pack, but the pack also needs other electronic content. The pack and system designer must implement cost effective hardware and software to provide the user with the greatest possible run time and the most accurate information possible on the status of battery. To do this requires the ability to monitor the current flowing into and taken out of the battery over a wide dynamic range⁵. The circuit must factor in temperature, battery cycle history, battery chemistry, charge/discharge state, charge and discharge rates, battery age, and perhaps other conditions (such as violations of temperature minimum/maximum, over current conditions or over/under voltage excursions) to achieve the highest accuracy gauge of remaining capacity and battery life.

5. A system in idle state might consume as little as a few milliamps, while pulses of several amps are not uncommon in portable computer graphic subsystems or during spin-up of disk drives.

Finally, battery pack electronics must be very small, to fit within ever smaller battery pack geometries. Space requirements depend on the desired level of pack functionality and the level of electronic integration.

Cell Balancing

State of the art Lithium Ion batteries from mainstream manufacturers have a high standard of quality, with voltages variations of less than 50mV cell to cell. A careful examination of the operation of the protection circuits, however, reveals an obstacle that the pack designer needs to consider. Since, with most protection circuits, the pack stops charging when any ONE of the cells reaches the overvoltage limit, there may be other cells that are below the limit and not fully charged. Additionally, the pack will shut down when ONE of the cells reaches the minimum voltage, even though other cells may not be at the minimum value.

The mismatch of the voltage between cells has two effects. First, it reduces the overall capacity of the pack. All the cells are not fully charged nor discharged, even though the electronics sense that the pack is fully charged or discharged. This leads to reduced run time. Second, having cells charged or discharged to different values leads to increasing pack imbalances and reduced cell life.

Another factor that leads to cell imbalances is temperature. This is especially true in newer portable PCs that have a high performance CPU that generates more heat than surrounding circuits. Placing a battery pack in close proximity of that CPU can result in a temperature gradient across the battery pack of 20°C. This can cause the cells in the pack to charge or discharge at vastly different rates, accentuating cell disparities.

A typical cell balancing circuit provides a mechanism for dealing with these potential or actual cell imbalances. A resistor and FET across each cell (or parallel cell combination) either discharges a specific cell or diverts a charging current from a particular cell. Through software algorithms and/or hardware, a the cell balancing scheme strives to keep the battery cell voltages equal to each other (with a specified tolerance).

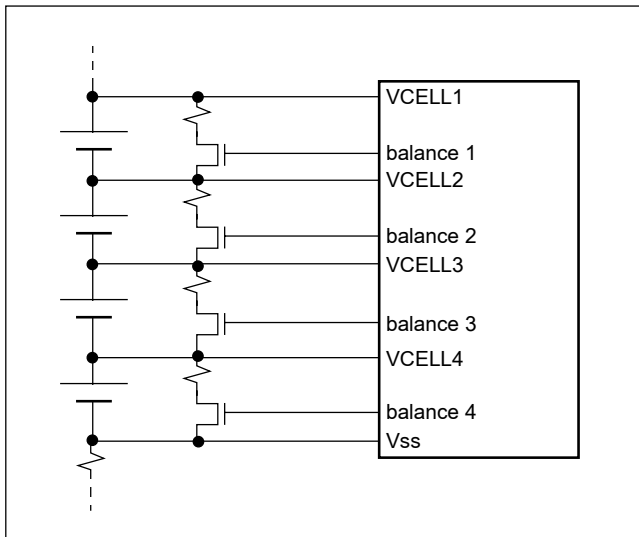

Figure 11. Cell balancing circuits

There are several ways to implement cell balancing and the selection of the resistor and FET depends on the implementation method, end application, and cell chemistry. Some cell balancing options are:

- When any cell reaches an overvoltage condition, charging stops and all over-voltage cells are partially discharged through an FET and resistor during the next discharge cycle.
- When any cell reaches an over-voltage condition, charging stops. Marking the over-voltage cells at this time allows the controller to partially bypass the over-voltage cells while the other cells continue to charge normally.
- When the pack recovers from an under voltage condition, or even during normal operation, voltages between cells can be compared and overvoltage cells partially bypassed as necessary during the charging sequence to equalize the cells.
- Based on history of the pack, some cells might be partially bypassed during charge or discharge based on specific conditions.

Each of these techniques, combinations or variations can improve the capacity and life of the cells in the pack.

When designing cell balancing circuits, it is important to keep in mind that Li-ion batteries have a large capacity (1500 mA/h is typical, with capacities to 2000mAh in the near future), so balancing of the cell voltages either takes a long time (tens to hundreds of seconds) or requires an FET that can handle a great deal of current (amps) to balance within seconds. In either case, the best time to do cell balancing is most appropriately conducted at the end of charge condition, when the voltage is higher and drops faster under a load than it does at the cell working voltage. Note: the voltage also drops quickly at the end of charge condition, but typically this is an unacceptable time to balance the pack by draining extra charge from a cell, since it leads to premature system shut down.

Smart Battery Standards

Adding intelligence to the battery pack is a very recent development. As such, there is a wide disparity of how smart batteries are implemented. Some standards are emerging, however these are currently being driven by the laptop computer manufacturers. In systems with only one cell batteries, such as cellular telephones, cost constraints limit the number of operations possible within the pack, complicating the development of standards.

Communication between the battery pack and the system is an important consideration. This interface should have few signal lines to reduce the number of connections at the pack. Many single cell battery packs, such as those found in cellular telephones, use a one wire interface. In a one wire interface, a one or zero is determined by the duration of a "0" on the line. This type of interface provides an asynchronous link. There are currently three different one wire standards, each slightly different from the others. Due to the intrinsic nature of the operation of the one-wire interface transmission speeds are very low. This speed is acceptable in low cost systems, because there is typically minimal information passed to the host. In battery packs with multiple cells, however, more information is needed by the host, requiring higher interface speeds.

A two-wire communication link provides a synchronous communication between the system host and the battery pack. A typical interface is based on the I2C specification from Philips. In this case, one wire provides the data signal and the other provides a clock signal. Embedded start and stop bits provide command synchronization.

In 1996, Intel (along with a number of other companies) developed a variation of the I2C bus for the PC called the System Management Bus (SMBus). This uses the same two wires as the standard I2C bus, but adds additional low voltage options and restrictions on how long one device can control the bus before releasing it for other devices.

As part of the development of the SMBus, Intel and others created the Smart Battery Standard. This specification adds a protocol on top of the SMBus interface and defines a set of commands for communication between the battery pack, a battery charger, a battery selector circuit, and the host. While not all of the commands and communication protocols are necessary, they provide a common framework from which all PC system designers and battery pack providers can work. Using the SMBus standard in non-PC applications also gives the designer a starting point for developing a communication procedure.

For more information about the Smart Battery System and the SMBus, please look on the world wide web at <http://www.sbs-forum.org>.

SUMMARY

This application note has explored some of the concepts of batteries, how they work and some of the design considerations associated with battery pack development. The idea of smart batteries is an emerging and intriguing area of development. Because of the sudden and rapid changes in this area, however, there are many new concepts and new, but evolving, standards. Battery chemistry, too is improving rapidly. With these improvements come greater capacity and longer system run time, but also greater risks. These new batteries need tight tolerance in the design for safety, programmability of thresholds for flexibility, and new techniques for monitoring current in and out of the pack to achieve maximum available cell capacity and least abuse of the cells.

FOR MORE INFORMATION

This application note was condensed from source material originating from many sources, including those listed below. Additional details on battery chemistry, recent industry trends and smart battery standards are available through these sources.

Huret, Barry, Huret Associates, Inc., Yardley, PA.

Linden, David, "Handbook of Batteries," McGraw-Hill, Inc., 1995.

Panasonic, "Lithium Ion Batteries Technical Handbook", 1998

Vincent, Colin and Scrosati, Bruno, "Modern Batteries, An Introduction to Electrochemical Power Sources," John Wiley & Sons, Inc. 1997.

Intel Corporation, et al., "System Management Bus Specification, Revision 1.1," December 11, 1998. (<http://www.sbs-forum.org>)

Intel Corporation, et al., "Smart Battery Data Specification, Revision 1.1," December 11, 1998. (<http://www.sbs-forum.org>)



LittleDiode supplies new, hard to find or obsolete electronic components and semiconductors all over the world.

With over two million different components listed you are sure to find the part you need.

Feel free to visit us today at our online store:

LittleDiode.com

Looking forward to providing you with the best possible service.