

L6567: DESIGN HINTS

An integrated ballast design has been made with L6567 IC. The chosen topology is an half bridge inverter. L6567 provides all the necessary functions for driving the external power mosfets and for pre-heat, ignition and steady state operations control of the lamp. The minimum part count required makes L6567 optimal for compact fluorescent lamp driving.

The design is intended for 15W CFL (or similar one) and for 220V±20% mains.

Introduction

The circuits to drive CFL have usually the following block diagram:

Figure 1. Block Diagram

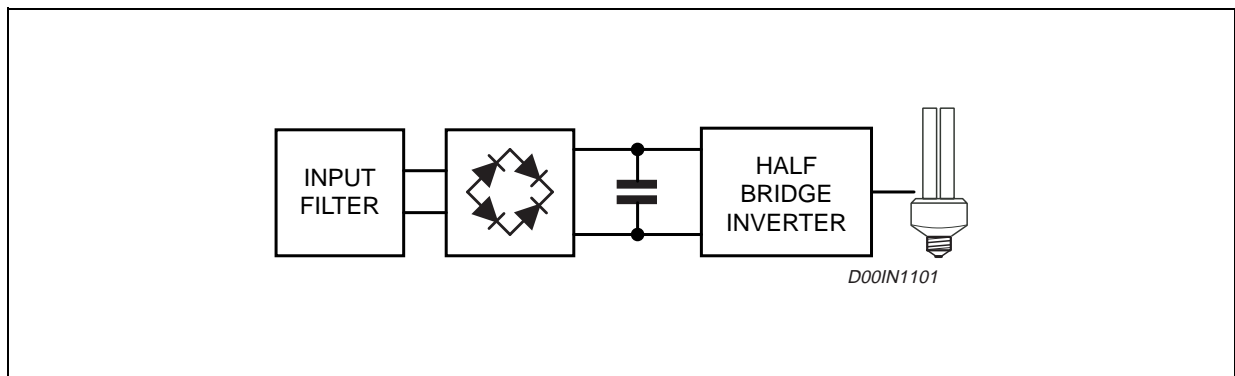

There are three sections: an EMI filter, a diode bridge rectifier that gives the rectified mains, (then smoothed by a filtering capacitor), and a half bridge inverter.

There is usually no voltage pre regulator for the High Voltage Bus (HVB), so the bus voltage will depend on the mains. A key point of L6567 is the load current regulation according to the bus value, that means that the power in the lamp is constant, not depending on mains value.

The high frequency inverter topology is a very efficient one, because of the zero voltage switching principle, that let the mosfet switching losses to be held to the minimum: just the turn on one. The "capacitive mode" protection implemented in L6567 helps preventing mosfet hard switching.

L6567 is able to control a preheat time to make lamp ignition easier and lamp life longer.

The main phases of circuit working are described in the following sections: start up, preheat, ignition and steady state condition. The circuit schematic we will refer to is shown below:

Figure 2. Application Schematic

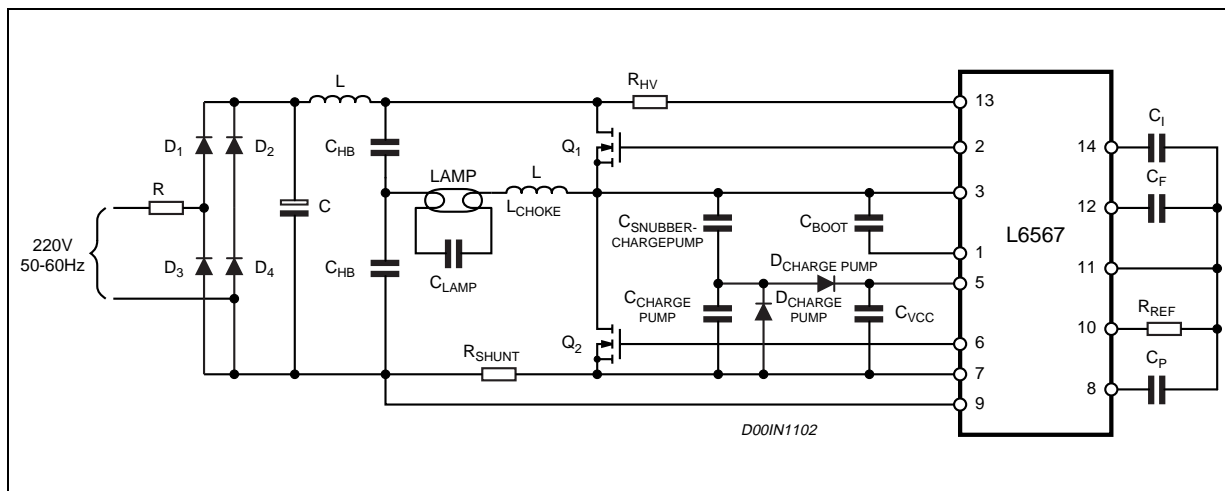

The way to get the right components value will be shown in the last paragraph.

Start up

As soon as the mains is applied a high voltage appears across the filtering capacitor C and the half bridge inverter (Q₁ and Q₂). L6567 is powered through R_{HV}: the current flows from HVB to C_{VCC} through R_{HV} and L6567. When C_{VCC} voltage reaches V_{SLOW1} (max. 6V) the low side mosfet Q₂ is turned on while the high side mosfet Q₁ is turned off, in order to charge the bootstrap capacitor (C_{BOOT}). When C_{VCC} voltage reaches V_{SHIGH1} (typ. 11.7V) the oscillator starts and the R_{HV} pin is no more involved in providing C_{VCC} charge: it is provided by the charge pump connected to the half bridge midpoint (pin 3 OUT). A high voltage capacitor is needed and it is used both for the charge pump and for snubber function.

Preheat phase

A preheat sequence is done to assure a longer lamp life: a small current is delivered to the lamp cathodes to warm them, in order to make ignition easier.

We refer to a very simple lamp model: before ignition no current flows in the lamp, and the only conductive paths are the electrodes, that can be seen as two small resistors (see fig. 3.A). After ignition, current flows between the electrodes, and the lamp can be seen as a resistor connected between them. The value of this resistance can be evaluated as the ratio between the nominal lamp power and the nominal voltage (squared) across the lamp. The equivalent load connected to the midpoint of the half bridge is shown in fig. 3.B (the filaments resistances have been disregarded).

Figure 3. Lamp equivalent load

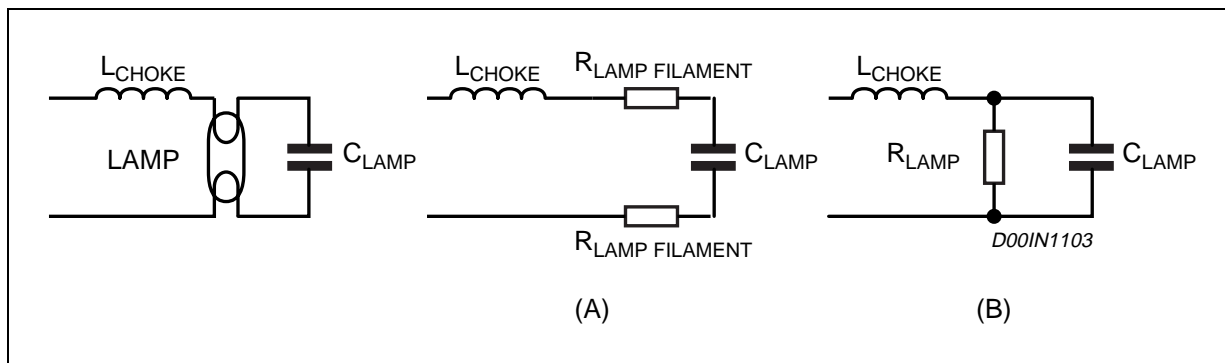

We will have two different transfer functions ($= V_{LAMP}/V_{HALF_BATTERY}$) :

Figure 4. Transfer functions

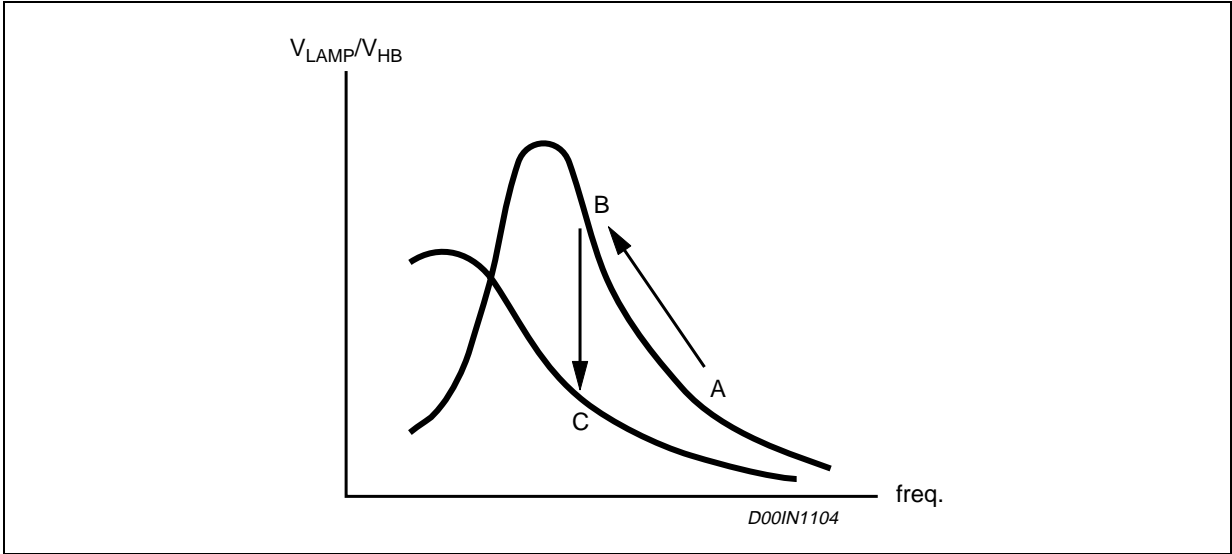

The preheat phase is typically in the “A” part of the upper characteristic: here we have a few KHz resonant frequency (See fig 3.A), small gain, so the voltage across the lamp is much smaller than the ignition one. The frequency of the oscillator is decided according to the current we want to flow in the lamp cathode.

There is a pretty simple way to determine the needed preheat current when it is not specified by lamp characterization: if R_0 is the filament resistance at room temperature, we have to warm the filament so that after preheat time $R(T_{PRE}) \sim 3R_0$ (as a rule of thumb). Moreover we have to do it with a current that allow us to use reasonable preheat time: the end customer will not wait for a long time before the lamp being on, but T_{PRE} has not to be so short to be out of control.

We can force a fixed DC current in the filament and we can measure the voltage across it: when it is three times the initial one, we have reached the needed preheat time.

A simple set up is shown in fig. 5.

Figure 5. Preheat Time and Current Measurements set up

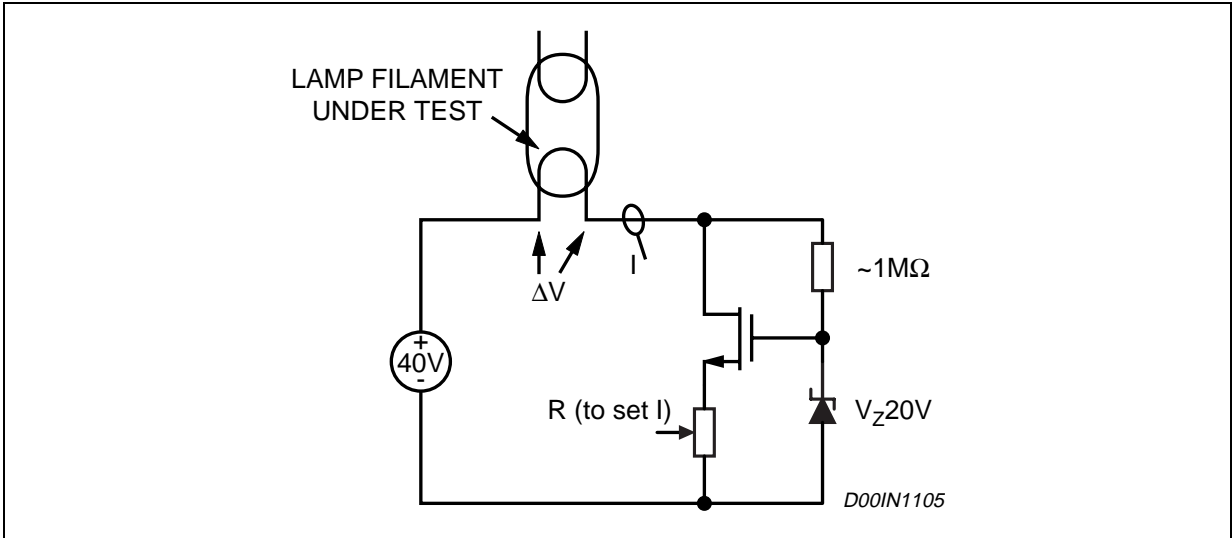

AN1234 APPLICATION NOTE

We have measured different lamp types with the following results:

Thin cathode lamps	Thick cathode lamps	R_0 [ohm]	Current mA	$3R_0$ time [s]
Philips 11W		15	200	1.4
			230	1
Sylvania 15W		12	250	0.7
			300	0.3
	Light of America 27W	1.7	525	3.5
			775	1.2
	Light of America 42W	3	300	2.5
			390	1.5
			510	0.42

Typical preheat times are nearly 1s (0.5-1.5s).

When we have set the right I_{PRE} - T_{PRE} values, we have to use them taking into account the model of fig.4. Here we have a resonant circuit, and in "A" zone we are far from the resonant frequency: the current wave form is not sinusoidal, but is nearly triangular. Using the rms. current value times R_{SHUNT} you have the voltage that is compared to pin 9 internal threshold. Setting R_{SHUNT} we set the preheat current and, as a consequence, the preheat frequency. The preheat time is set by C_P capacitor, connected to pin 8.

Ignition phase

After preheat time has elapsed L6567 oscillator sweeps down toward lower frequency, using the "B" part of fig. 4 characteristic. In this way the gain increases, and the voltage across the lamp and across C_{LAMP} capacitor increases too. When the frequency approaches the resonant frequency the voltage gain is very high, and the voltage across the lamp will reach the ignition one: the lamp strikes on and the load will look like model B in fig.3: that means we are now in "C" part of fig. 4 lower characteristic, with a lower gain and not so near to the new resonant frequency.

If the lamp doesn't ignite the oscillation frequency could cross the resonant frequency and go to the left side of the upper characteristic. The frequency range lower than the resonant frequency is dangerous for mosfet switching: they switch in capacitive mode, that means there is no more zero voltage switching, and the mosfet switch with the full HVB across source and drain. We don't have this problem with L6567: the IC provides a capacitive mode protection, sensing R_{SHUNT} voltage, and forcing the frequency towards higher values until we are at frequency higher than the resonant one. The ignition frequency sweep lasts the time needed to reach the set working frequency or, maximum, $15/16T_{PRE}$. The sweep rate is set by C_I capacitor (pin 14).

Burn phase

When the lamp is properly ignited we are in the burn phase. The minimum oscillator frequency (F_{MIN}) is set by R_{REF} and C_F (pin 10 and 12). There are two main control functions performed by L6567: there is the capacitive mode protection that has already been enabled in the ignition phase, and there is the feed forward control. This second function mainly sets the working frequency in the burn phase. L6567 checks the rectified mains value (sensing R_{HV} current) and changes the working frequency to maintain constant lamp power. There is also the filtering action of C_P to avoid the 100Hz mains ripple. Without feed forward frequency sweep the high voltage bus voltage variations would be applied to the half bridge inverter, and as a consequence to the lamp: sudden

increase and decrease of lamp power could cause a shortening of lamp life. With feed forward control the lamp works at nearly the same power level regardless the mains variation. Another feature of L6567 is the chance to set the dead time value with the resistor R_{REF} at pin 10.

Setting components

In this application there are components typical of nearly every ballast application, to which general rules apply:

Mosfets have to be chosen taking care of the High Voltage Bus value as far as V_{DSMAX} is concerned, and using the lower R_{DS(on)} for thermal consideration. With 220V mains 500V mosfet class is ok, and R_{DS(on)} times max. current has to be a withstandable dissipated power. Considering the high dV/dt due to the switching, NB mos are safer than NA type.

After choosing the lamp, P_{LAMP} and V_{LAMP} set a constrain to L_{CHOKE} value: L has to be the main components as far as I_{LAMP} setting:

$$I_{LAMP} = \frac{P_{LAMP}}{V_{LAMP}} = I_L = \frac{V_L}{X_L(f=f_{WORKING})} = \frac{V_{HB} - V_{LAMP}}{X_L(f=f_{WORKING})}$$

That means:

$$L = \frac{(V_{HB} - V_{LAMP}) \cdot V_{LAMP}}{2 \cdot \pi \cdot f_{WORKING} \cdot P_{LAMP}}$$

C_{LAMP} has the aim to prevent V_{IGNITION} across the lamp to be reached during preheat, so:

$$V_{CLAMP} = I_{PRE} \cdot X_{CLAMP}(f = f_{PRE}) \ll V_{IGNITION}$$

C_{HB} capacitors are the half battery capacitors, the bigger they are the smaller the ripple of the voltage across the resonant load, 100nF is the commonest value.

C_{BOOT} capacitor has to be chosen according to the mos type: as a rule of thumb you can use:

$$C_{BOOT} \gg C_{MOS_equ.} \sim \frac{Q_{tot_gate}}{V_{GATE}} \quad (\text{see AN994 for further details})$$

Mosfet have no big equivalent capacitors in this kind of application, and a 100nF capacitor is often used.

The charge pump components have no special requirements, except the capacitor connected to the OUT node that has to withstand a voltage swing equal to the High Voltage Bus value, and so it has to be properly rated (i.e. 500V).

The remaining six parts: R_{SHUNT}, R_{HV}, R_F, C_I, C_P, C_F are strictly related to the IC working. L6567 is able to set really a big deal of application parameters with a very few number of external components, namely the six key components listed below. As a logical consequence, the same component is not related to a single application characteristic, but to two or more.

AN1234 APPLICATION NOTE

The table below summarize these relationships (see L6567 datasheet for further details):

characteristic		components
burn phase minimum freq.	F_{MIN}	R_{REF} & C_F
feed forward freq.	F_{FF}	C_F & R_{HV}
preheat and ignition time	T_{PRE} & T_{IGN}	C_P & R_{REF}
preheat freq.	F_{PRE}	R_{SHUNT} & load
dead time	T_{DT}	R_{REF}
freq. sweep rate	dF/dT	C_I
start up current		R_{HV}

There are key part (i.e. R_{REF}) that are related even to three parameters (i.e. F_{MIN} , T_{PRE} , T_{DT}).

The suggested order to set parameters is the following:

- Set R_{HV} considering start up current and dissipation problem;
- Set C_F to have the feed forward frequency range: $F_{FF} = I_{RHV} / (k_1 \cdot C_F)$;
- Set R_{REF} to fix the minimum working frequency: $F_{MIN} = k_2 \cdot R_{REF} \cdot C_F$;
- Set C_P to fix the preheat time: $T_{PRE} = k_3 \cdot C_P \cdot R_{REF}$;
- Now we have two parameters that are related just to a parameter: R_{SHUNT} to the preheat current (and frequency) and C_I that is related to the frequency sweep rate.
- At the end we have two parameters that are related to parts already chosen:
 $T_{DT} = k_4 \cdot R_{REF}$ and $T_{IGN} = k_5 \cdot T_{PRE}$.

We can see a numerical example.

R_{HV} choice

We begin from the start up current required to charge C_{VCC} : it has to be greater than the IC consumption before start up ($I_q = 250\mu A$), and the greater it is the shorter the start up time is. The problem is the dissipation: the greater the current, the greater the dissipation on R_{HV} . We have to make a compromise between these two settlements, starting from reasonable current value. We can start from: $I_{START_UP} = 700\mu A$ and $C_{VCC} = 100nF$. We get:

$$T_{START_UP} = \frac{Q}{I_{START_UP}} = \frac{V \cdot C_{VCC}}{I_{START_UP}}$$

If we consider V_{LOW1} and V_{HIGH1} (max. 6V and 12.7V) we have $T_1 \sim 0.9\mu s$ and $T_2 \sim 1.8\mu s$, that are reasonable time for this kind of application. It means that the IC starts working after $\sim 2\mu s$.

We can use the max. rms. mains value to calculate the Rc- value. If the mains is $220V \pm 20\%$ we have:

$$R_{HV} = \frac{310V}{0.7A} \sim 443k\Omega$$

We have to check if this value gives dissipation problems: it is safer to use the peak mains voltage, so:

$$P_{DISS} = \frac{V_{MAX}^2}{R_{HV}} \sim \frac{370V^2}{440k\Omega} \sim 0.3W$$

It is cheaper to use 1/4watt resistors, so we can choose two 220Kohm resistors.

C_F choice

We can choose C_F in order to set the feed forward frequency range. A useful formula that fits pretty well the L6567 behavior is:

$$F_{FF} = \frac{I_{RHV}}{k_1 \cdot C_F}$$

Where k₁~121 (see in L6567 datasheet the fitting between calculations and measurements). It is useful to use the datasheet characterization to select the proper frequency range. An example is the graph in fig. 6.

Figure 6. Freq. vs. I_{RHV} @ different C_F

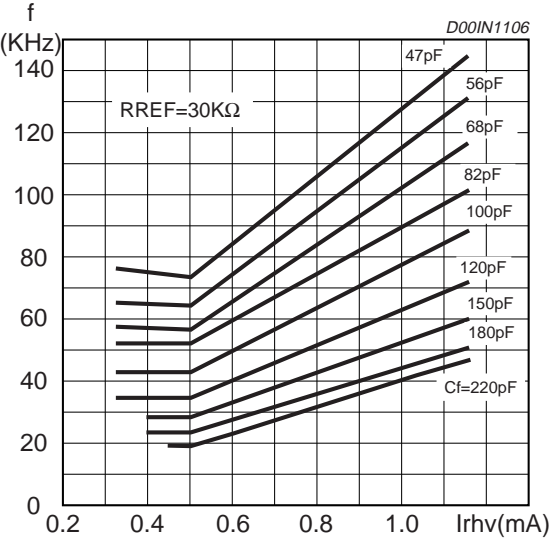

We have to choose the desired frequency range vs. the I_{RHV} range, as done in fig.6, and we have the C_F characteristics. If the frequency ranges from 40 to 60 kHz a good capacitor value is 100pF.

When we measure the frequency on the board we have to measure the mosfets gate on-off frequency (i.e. pin 6). We don't have to put the probe on C_F. On C_F we will see a triangular waveform (see L6567 datasheet characterisation) but with a wrong frequency: the probe capacitor is some pF (i.e. 8pF), that is not negligible compared to a 100pF capacitor.

R_{REF} choice

After choosing C_F value we can set the F_{MIN} value with the formula:

$$F_{MIN} = (8 \cdot R_{REF} \cdot C_F)^{-1}$$

If F_{MIN} is 40 kHz, we get R_{REF}=31250ohm, that may mean a R_{REF} commercial value of 30Kohm.

C_P choice

We fix C_P value setting the preheat time:

$$T_{PRE} = 224 \cdot C_P \cdot R_{REF}$$

We look in the preheat current-time table shown before a good setting for a 15W lamp. We choose the following preheat condition: I_{PRE}~250mA and T_{PRE}~0.6-0.7ms. We get C_P~100nF.

R_{SHUNT} choice

R_{SHUNT} sets the preheat current and (as a consequence) the preheat frequency.

We have already chosen I_{PRE} (~250mA) from the lamp filament characterization table. This value is a DC one, so it is also the rms. one. During preheat we work in a strongly inductive mode (see fig. 4, range A), so the current is nearly triangular shaped. With this approximation we are allowed to use the following formula:

$$I_{RMS} = \frac{I_{PP}}{\sqrt{12}}$$

L6567 compares the peak current times R_{SHUNT} with an internal threshold (~600mV typ.):

$$V_{R_{SHUNT}} = \frac{I_{PP}}{2} \cdot R_{SHUNT}$$



AN1234 APPLICATION NOTE

At the end we get:

$$R_{SHUNT} \sim V_{R_{SHUNT}} \cdot \frac{0.577}{I_{PRE_RMS}}$$

And we have a 1.3-1.4 ohm shunt resistor.

C_I choice

C_I value is the main factor that sets the frequency sweep rates during preheat, ignition and feed forward phase. The suggested value is 100nF (see datasheet characterization).

Dead time and ignition time

There are formulas that relate T_{DT} and T_{IGN} to external parts:

$$T_{DT} = 46.75 \cdot 10^{-12} \cdot R_{REF}$$

$$T_{IGN} = \frac{15}{16} \cdot T_{PRE} = \frac{15}{16} \cdot 224 \cdot C_P \cdot R_{REF}$$

All these parts have already been set, as a consequence we have T_{DT}~1.4μs and T_{IGN}~0.6s.

Usually these are not key parameters, and these values are reasonable. If this is not the case we have to iterate the process, changing the order in which we set the external parts (starting from the most critical ones).

With the above calculations we get the following part list:

Filtering parts	R	47 Ω
	C	3.3μF 400V
	L	820μH 140mA
Rectifier bridge		DF06N
Ballast parts	C _{HALF_BATTERY} (2)	100nF 250V
	L	3.1mH
	C _{LAMP}	3.9nF 400V
	Mosfets (2)	STP2NB50
	R _{SHUNT}	1.3 Ω
	C _{SNUBBER-CHARGE_PUMP}	470pF 500V
	C _{CHARGE_PUMP}	680pF 50V
	Charge pump diodes (2)	BAS16,1N4148
	C _{VCC}	100nF 50V
	R _{HV1} R _{HV2}	220KΩ
	C _P , C _I	100nF 50V
	R _{REF}	30KΩ
	C _F	100pF
	IC	L6567

Information furnished is believed to be accurate and reliable. However, STMicroelectronics assumes no responsibility for the consequences of use of such information nor for any infringement of patents or other rights of third parties which may result from its use. No license is granted by implication or otherwise under any patent or patent rights of STMicroelectronics. Specifications mentioned in this publication are subject to change without notice. This publication supersedes and replaces all information previously supplied. STMicroelectronics products are not authorized for use as critical components in life support devices or systems without express written approval of STMicroelectronics.

The ST logo is a registered trademark of STMicroelectronics
© 2001 STMicroelectronics - All Rights Reserved

STMicroelectronics GROUP OF COMPANIES
Australia - Brazil - China - Finland - France - Germany - Hong Kong - India - Italy - Japan - Malaysia - Malta - Morocco - Singapore - Spain
- Sweden - Switzerland - United Kingdom - U.S.A.
<http://www.st.com>



LittleDiode supplies new, hard to find or obsolete electronic components and semiconductors all over the world.

With over two million different components listed you are sure to find the part you need.

Feel free to visit us today at our online store:

LittleDiode.com

Looking forward to providing you with the best possible service.