

VIpower VB409: AN OFF-LINE AC/DC CONVERTER

N. Aiello - F. Macina

INTRODUCTION

The VB409 is an off-line AC-DC Converter. It supplies a 5V DC output with a current internally limited to 70mA. The device is made using the Vertical Intelligent Power (VIpower) M1-HV technology.

The first part of this paper covers the performance of the VB409. The second part describes a way to increase its efficiency.

In order to reduce the power dissipation a phase control method is used. The device is made up of two stages: a high voltage pre-regulator and a low voltage linear regulator.

The first stage provides a charging current to an external low voltage capacitor during a time period determined by an external divider which sets the conduction angle. This charge is used to feed the low voltage linear regulator stage.

Fig.1: VB409 Application Scheme

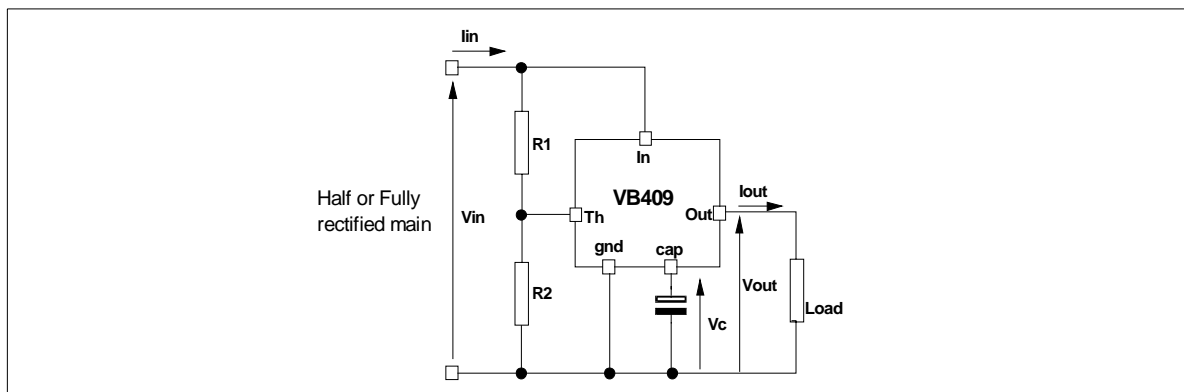
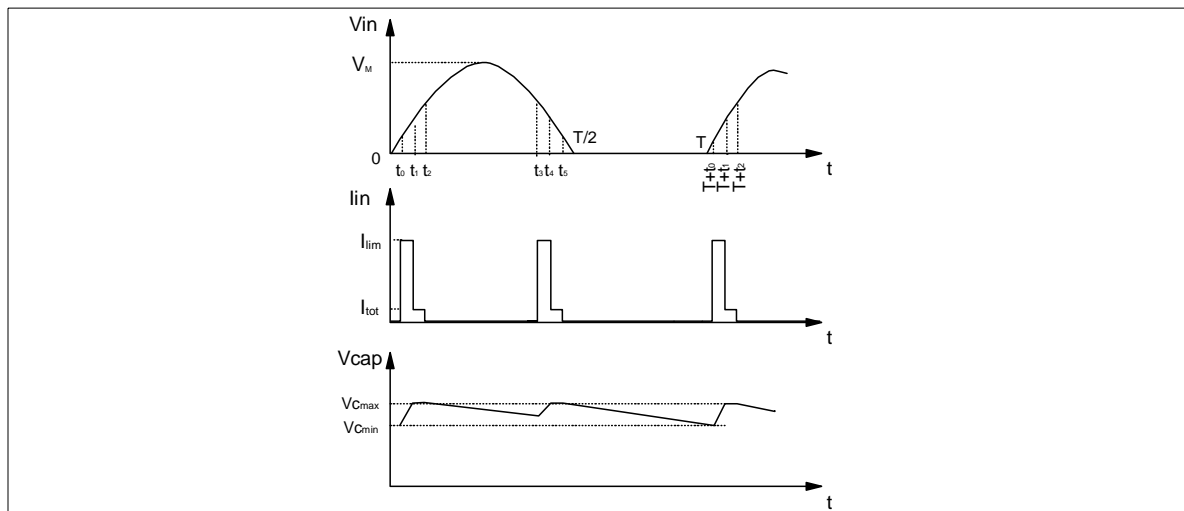

Fig. 2: Main Waveforms



AN1219 APPLICATION NOTE

DESIGN CONSIDERATIONS

Figure 1 shows the general schematic. Figure 2 shows the main waveforms for half wave rectification. Some general considerations about the board design and the device power dissipation can be made.

For an output current I_{out} and an internal quiescent current I_q it is possible to write:

$$Q_t = (I_{out} + I_q)T = I_{tot}T$$

Where Q_t is the continuous charge consumption of the low voltage regulator stage. This is also the charge which needs to be given to the capacitor during the conduction time of the high voltage switch.

Referring to Fig.2 it can be seen that the conduction time $t_5 \rightarrow (T + t_0)$ is greater than $t_2 \rightarrow t_3$

The capacitor value has to be chosen to guarantee the supply to the low voltage stage during this longer time interval. The best condition is to have the capacitor charged to the maximum voltage at t_5 time.

With this hypothesis it is possible to calculate t_5 :

$$v_{in}(t) = V_M \sin(\omega t)$$

If Δ is the drop on the trilinear power stage, the device is turned off when:

$$V_M \sin(\omega t_5) = V_{CM} + \Delta \quad \text{with } V_{CM} \text{ maximum capacitor voltage}$$

$$t_5 = \frac{1}{2\pi f} \arcsin\left(\frac{V_{CM} + \Delta}{V_M}\right)$$

The charge lost during interval $t_5 \rightarrow (T + t_0)$ is:

$$Q_1 = I_{tot}(T + t_0 - t_5)$$

With the hypothesis that all this lost charge is to be recovered during the first conduction period $t_0 \rightarrow t_2$ and the power stage immediately delivers the maximum current I_{lim} , the time t_1 needed is:

$$t_1 = \frac{Q_1 + I_{lim}t_0}{I_{lim}} = t_0 + \frac{Q_1}{I_{lim}}$$

This can be an operative condition, so that the external divider can be set to turn off the high voltage switch at t_1 . In the case of a conduction angle greater than the interval $t_0 \rightarrow t_1$ the high voltage stage power will work in regulation mode, that is, it will supply only the current I_{tot} . Assuming the real turn-off time to be t_2 , the high voltage stage will be switched on again at

$$t_3 = \frac{T}{2} - t_2$$

During the interval $t_2 \rightarrow t_3$ the charge Q_2 supplied by the capacitor is:

$$Q_2 = I_{tot}(t_3 - t_2)$$

This charge will be recovered at

$$t_4 = t_3 + \frac{Q_2}{I_{lim}}$$

If $t_4 < t_5$, once again the H.V. Stage will work in regulation mode.

In terms of power dissipation the following expression can be written:

$$P = \frac{1}{T} \int (V_{in}(t) i_{in}(t)) dt$$

The optimum value of t_2 is found by minimizing this function for t_2 .

Fig. 3: VB409 Application Scheme with Input Filter

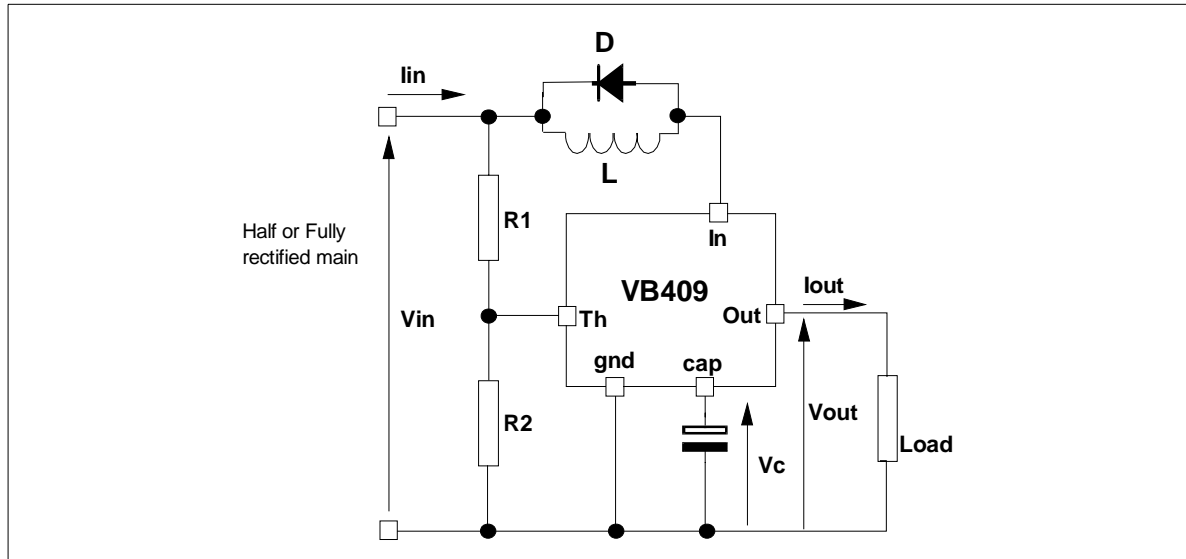

APPLICATION CIRCUIT TO IMPROVE EFFICIENCY

The circuit of figure 3 can be used to further decrease the power dissipation, and a comparison can be made with the standard circuit of (Fig.1).

The series inductance L, decouples the power switch from the mains, allowing it to work in the saturation region when it is on. The voltage divider must be connected before the inductance, in order to sense the mains and not the distorted voltage waveform after L.

The purpose of the diode D is twofold:

- 1) It limits the overvoltage across the VB409, due to the presence of inductance L, when the power switch is turned-off;
- 2) It is a discharge path for the energy stored in the inductance during the device conduction.

In the following waveforms the behavior of the VB409 is compared, using both the standard circuit and the modified one.

All the measurements have been done considering the same output current I_{out} (-24mA).

AN1219 APPLICATION NOTE

Fig. 4: Input Current and Voltage in Standard Configuration

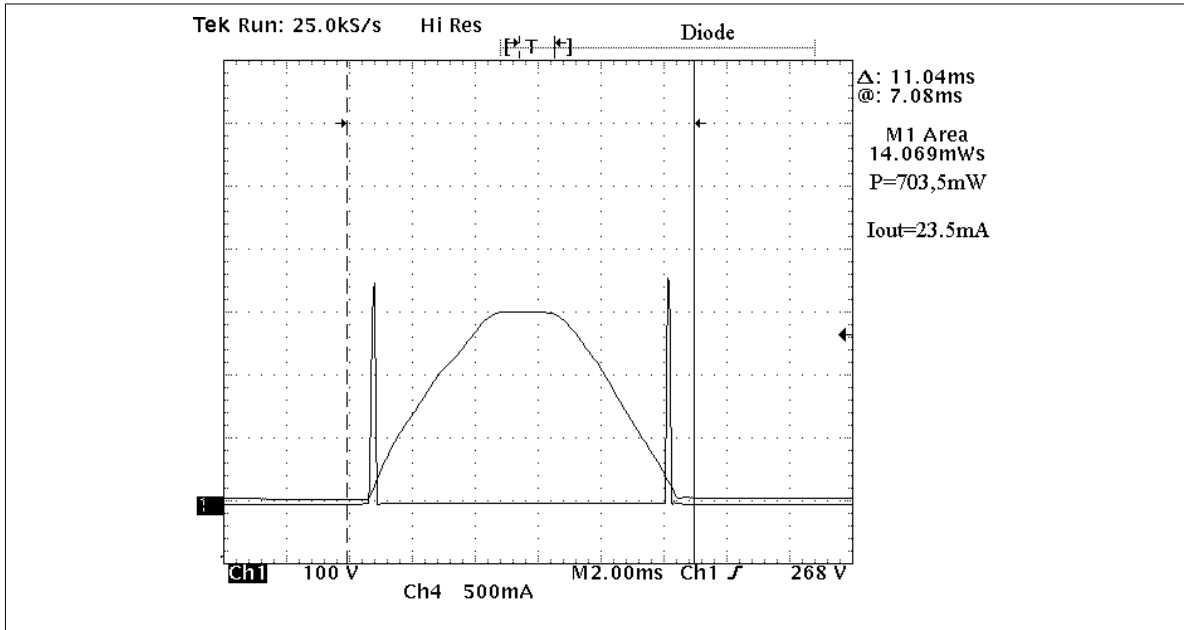

Fig. 5: Input Current and Voltage with Series Inductance

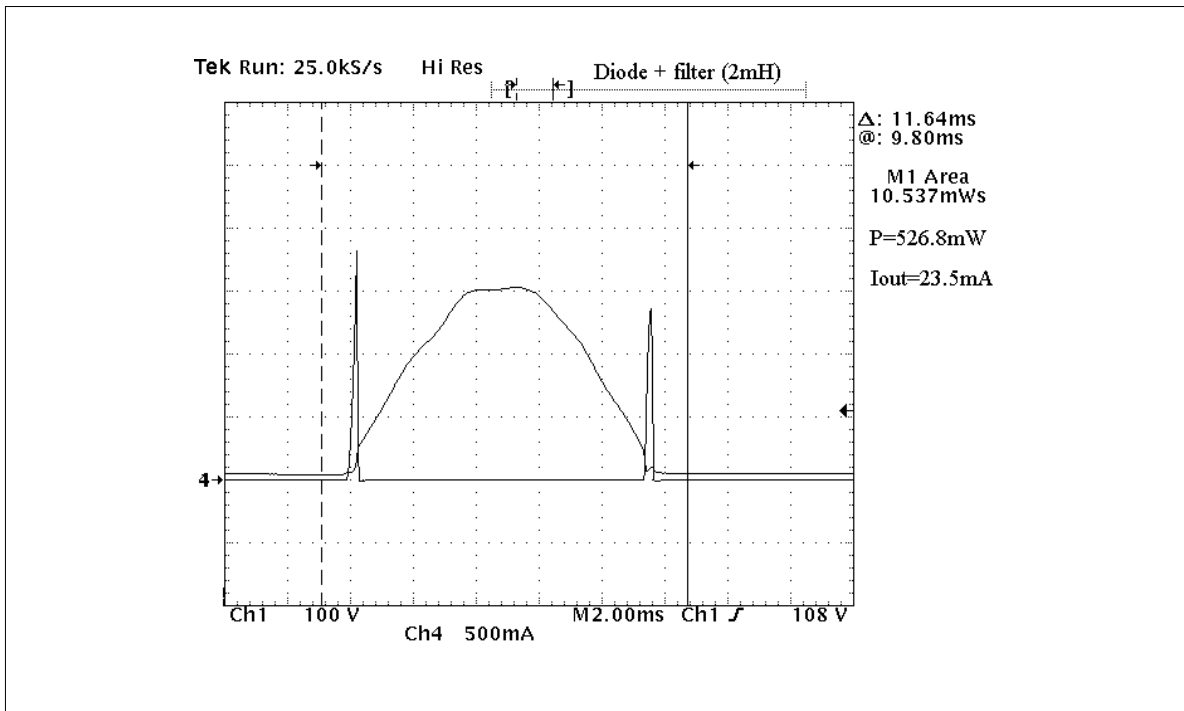

Fig. 4 shows the current and voltage input using the standard configuration. Fig. 5 shows the same waveforms using the topology of Fig. 3. with the series inductance. It can be seen that the power consumption is reduced by about 25%.

Fig. 6: First Pulse of Standard Configuration Zoom In

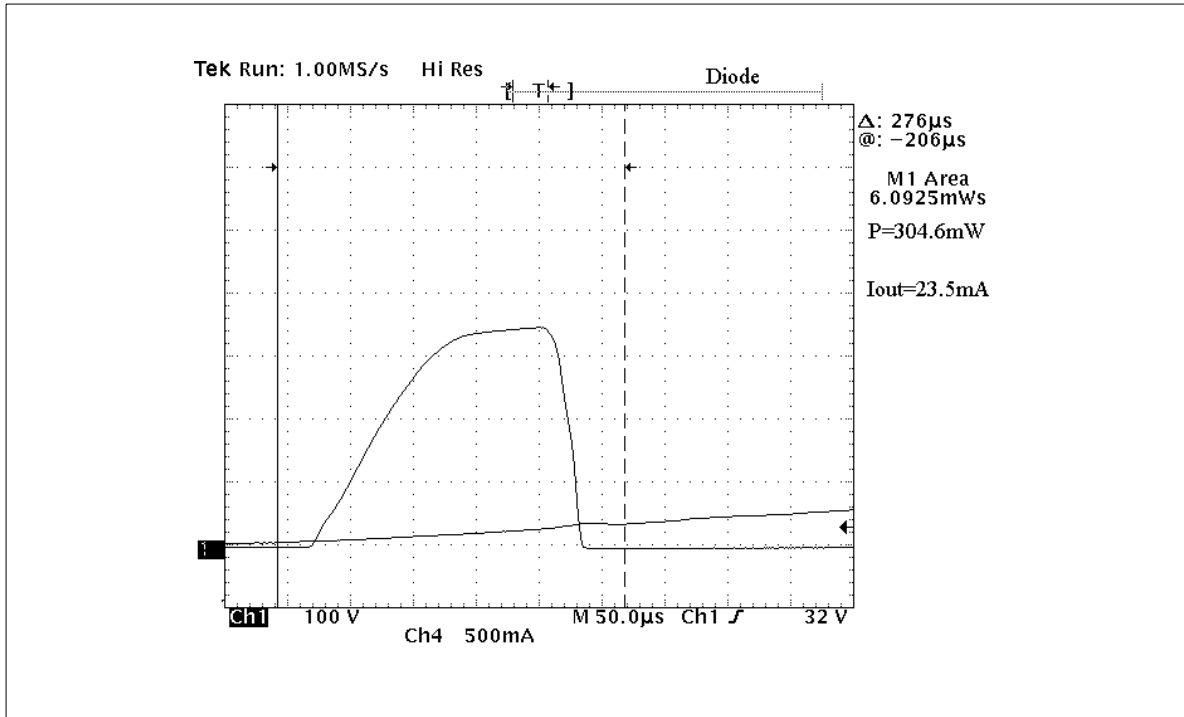
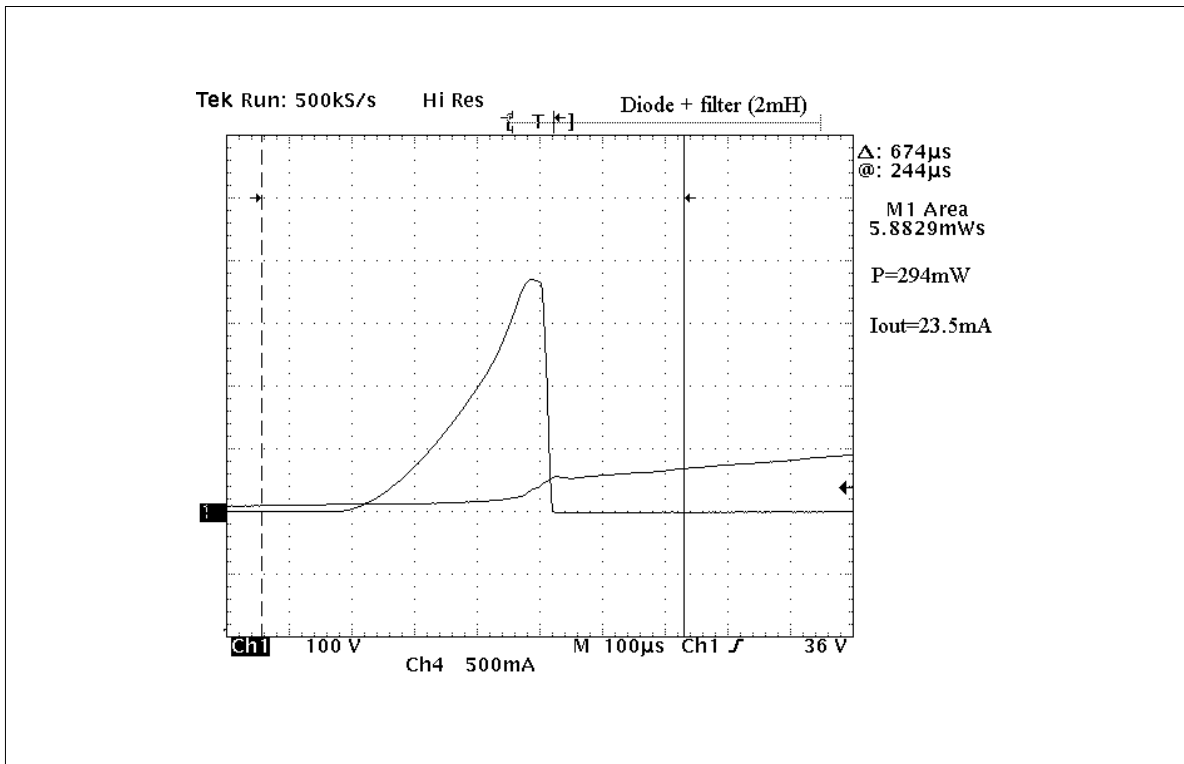

Fig. 7: First Pulse with Series Inductance Zoom In



AN1219 APPLICATION NOTE

Fig. 8: Second Pulse of Standard Configuration Zoom In

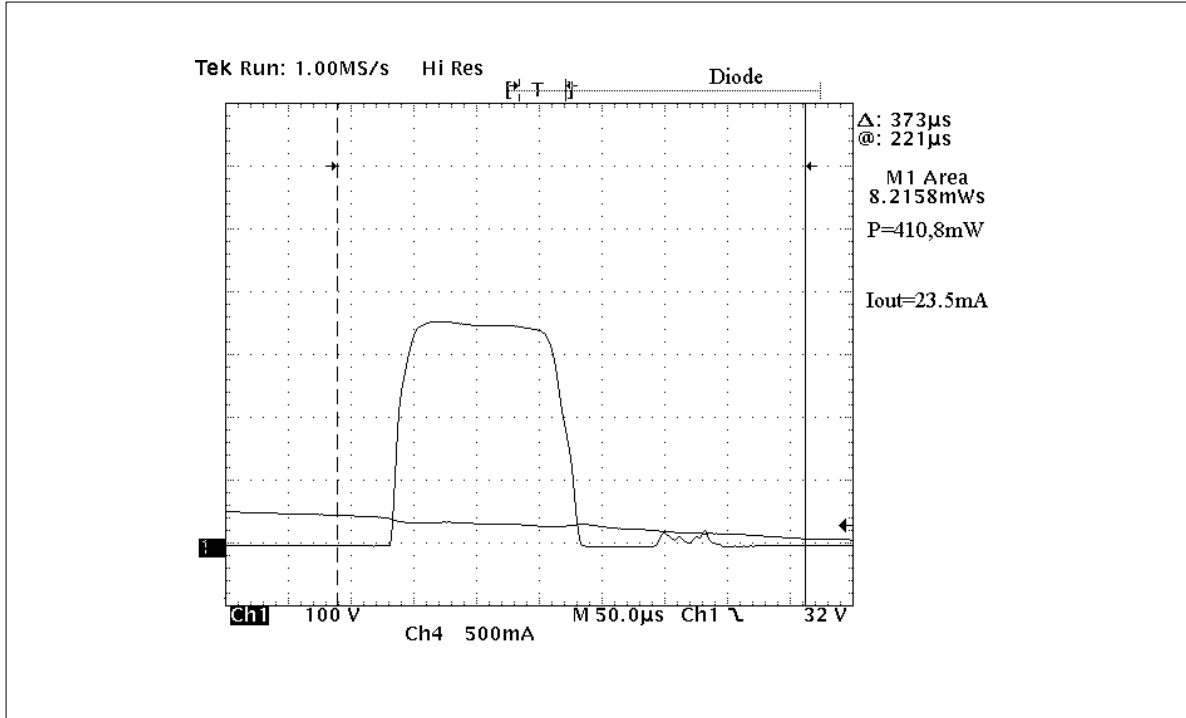

Fig. 9: Second Pulse with Series Inductance Zoom In

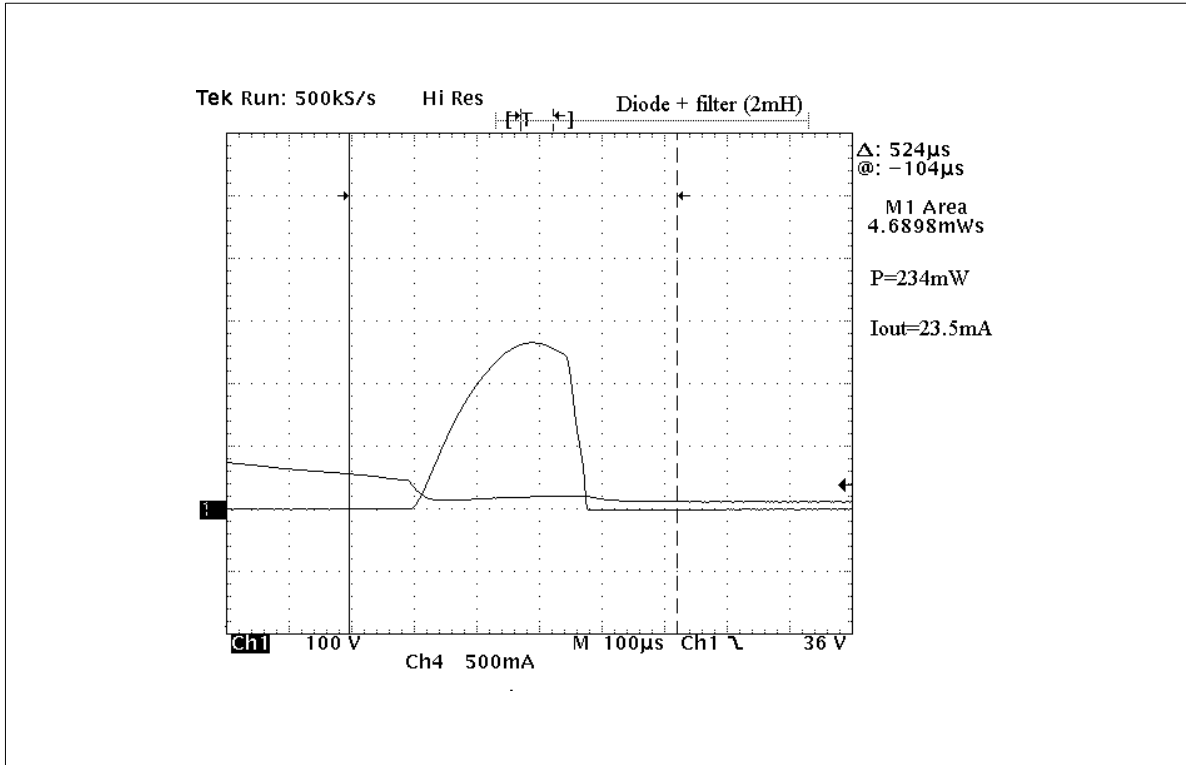

Fig. 6 and Fig. 7 respectively show the zoom of Fig. 4 and Fig. 5 during the rising edge of the input voltage, while Fig. 8 and Fig. 9 show the zoom of Fig. 4 and Fig. 5 during the falling edge.

The same measurements were repeated using a full wave rectified mains using a Graetz bridge; in this configuration the conduction occurs four times per period (T).

Figs.10-11 show the conduction current respectively with and without the series inductor, as well as the power dissipation in both configurations.

Fig. 10: Input Current and Voltage in Standard Configuration with Full Rectified Main

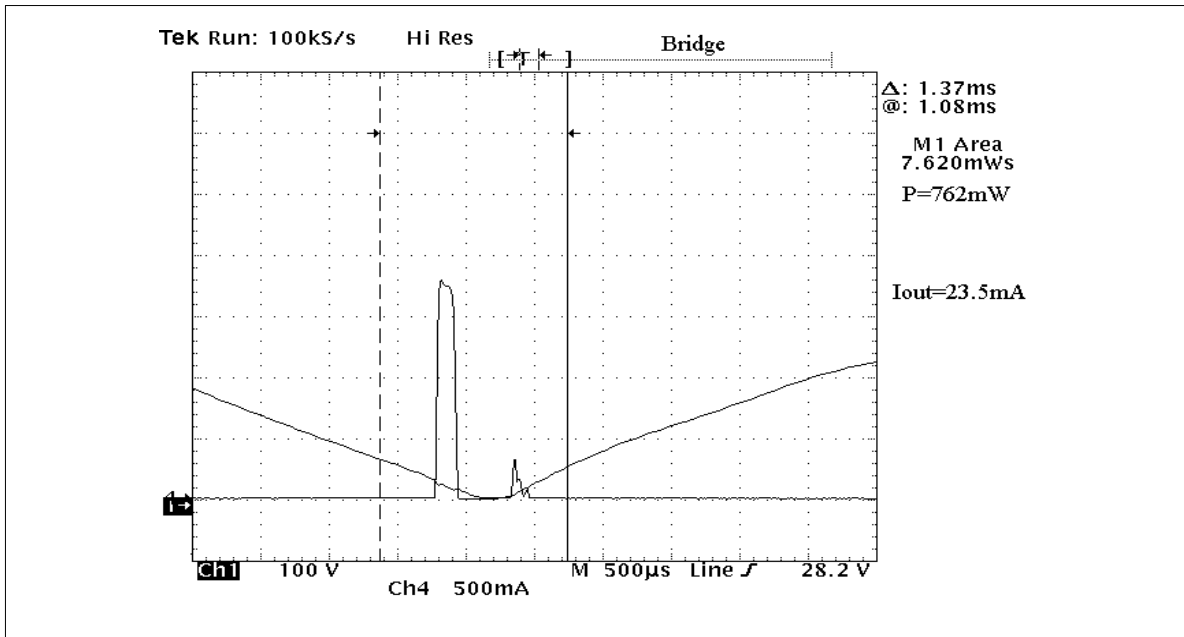
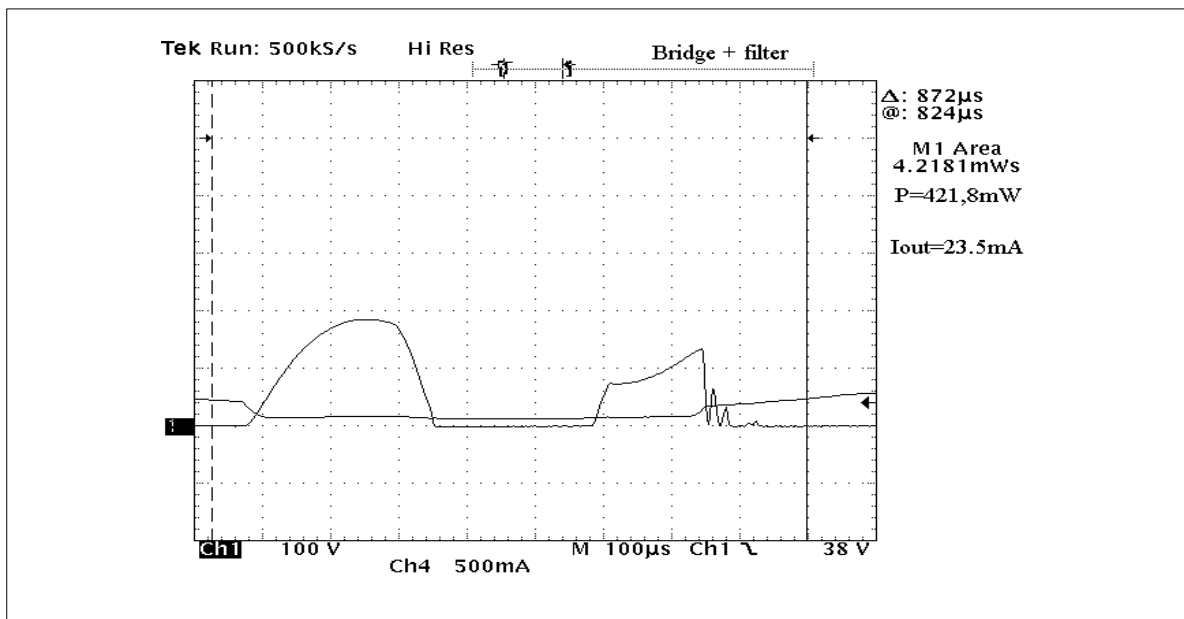

Fig. 11: Input Current and Voltage with Series Inductance and Full Rectified Main



AN1219 APPLICATION NOTE

Looking at the power dissipation it can be seen that there are no advantages in using the bridge without the series inductance L , in fact there is an increase in the power dissipation (762mW instead of 703.5mW).

However, it is possible to obtain an appreciable reduction of the power dissipation by employing the series filter. In this case (Fig.11) the power is reduced to 421.8mW representing a gain of 100mW compared to the half wave rectified configuration with series inductance (Diode + filter => $P=526.8\text{mW}$).

Information furnished is believed to be accurate and reliable. However, STMicroelectronics assumes no responsibility for the consequences of use of such information nor for any infringement of patents or other rights of third parties which may result from its use. No license is granted by implication or otherwise under any patent or patent rights of STMicroelectronics. Specifications mentioned in this publication are subject to change without notice. This publication supersedes and replaces all information previously supplied. STMicroelectronics products are not authorized for use as critical components in life support devices or systems without express written approval of STMicroelectronics.

The ST logo is a registered trademark of STMicroelectronics

© 2000 STMicroelectronics - Printed in ITALY- All Rights Reserved.

STMicroelectronics GROUP OF COMPANIES

Australia - Brazil - China - Finland - France - Germany - Hong Kong - India - Italy - Japan - Malaysia - Malta - Morocco -
Singapore - Spain - Sweden - Switzerland - United Kingdom - U.S.A.

<http://www.st.com>



LittleDiode supplies new, hard to find or obsolete electronic components and semiconductors all over the world.

With over two million different components listed you are sure to find the part you need.

Feel free to visit us today at our online store:

LittleDiode.com

Looking forward to providing you with the best possible service.