



ST7 pCAN PERIPHERAL DRIVER

by Central European MCU Support

INTRODUCTION

The Controller Area Network (CAN) norm defines a fast and robust serial bus protocol, suited for local networking of intelligent devices such as microcontrollers, sensors and actuators. It is now widely used, mostly in the automotive domain, but also for home automation and industrial equipment control.

Several members of the ST7 MCU family have a built-in CAN peripheral named pCAN, which allows them to be used as nodes in a CAN network. A software driver provided is by ST to help you start designing and writing applications using the ST7 pCAN cell.

The purpose of the following application note is to explain to you how to use the driver, and how it works. Thus, you can either build your software from the provided files, or modify them to meet specific needs.

You will find in this application note:

- a brief description of the CAN protocol
- an overview of the pCAN peripheral
- the complete description of the user interface
- the step-by-step development of an example application using the driver features
- a technical report including a description of algorithms and internal data types

Table of Contents

INTRODUCTION	1
1 CAN COMMUNICATION PROTOCOL	4
1.1 GENERAL CHARACTERISTICS	4
1.1.1 Protocol properties	4
1.1.2 CAN in the OSI reference model	5
1.2 CAN FRAME	6
1.2.1 CAN Data Frame	6
1.2.2 CAN Remote Frame	7
1.2.3 CAN Error Frame	8
1.2.4 CAN Overload Frame	8
1.3 PHYSICAL REPRESENTATION OF DATA	8
1.3.1 Bit Stuffing	9
1.3.2 Bit timing	9
1.4 ARBITRATION PHASE	10
1.4.1 Arbitration Phase	10
1.4.2 Message Acknowledgement	11
1.5 ERROR MANAGEMENT	11
1.6 ST7 PCAN PERIPHERAL	12
1.6.1 Main Features	12
1.6.2 Cell Behaviour	13
2 CAN DRIVER	15
2.1 USER INTERFACE	15
2.1.1 Files Furnished	15
2.1.2 Architecture	15
2.1.3 Principle of Use	16
2.1.4 Interrupts (ITs)	17
2.1.5 User Interface Description	19
2.2 HOW TO USE THE CAN DRIVER: A DEMO APPLICATION	27
2.2.1 Application	27
2.2.2 Cell Configuration	28
2.2.3 Implementing the Notification Functions	30
2.2.4 Transmissions outside the CAN Interrupt Function	33
2.2.5 IMPORTANT: Reentrant Functions	36
3 DETAILED DESCRIPTION	38
3.1 USER INTERFACE FUNCTIONS	38
3.2 INTERNAL FUNCTIONS AND DATA TYPES	41
3.2.1 Internal Data Types and Variables	41
3.2.2 Internal Routines	44
3.3 A FEW WORDS ABOUT DRIVER PERFORMANCE	55
3.3.1 CPU Load	55
3.3.2 Code Size	56

Table of Contents

4 DRIVER CODE	57
4.1 CAN.C	57
4.2 CAN.H	86
4.3 CAN_CUSTOM.C	90
4.4 CAN_CUSTOM.H	93
4.5 CAN_HR.H	96

1 CAN COMMUNICATION PROTOCOL

In the early 80s, electronic applications appeared in the automotive world. The need gradually arose to establish real-time communications between various types of on-board equipment.

In 1986, the CAN bus protocol, designed by Robert Bosch GmbH, was presented to the public for the first time. In 1989, the first silicon implementing the protocol was issued and in 1991, the first car equipped with a CAN network was produced.

Today, the protocol is an international norm (ISO 11898). Its relative simplicity, the wide availability of products and services in terms of chips, software libraries, starter kits, courses and training makes the development of applications relatively fast and cheap.

The CAN protocol provides the user with very reliable communication, with a powerful error detection/confinement mechanism. It allows baud rates up to 1Mbaud (for networks of up to 40m) which makes it able to support real time applications. The bus can of course be configured with lower speeds for larger networks (50kbaud for networks up to 1km long for example).

There were more than 150 million CAN nodes installed at the beginning of 1999.

1.1 GENERAL CHARACTERISTICS

1.1.1 Protocol properties

- Asynchronous serial bus (See “Bit timing” on page 9)
 - No clock signal is transmitted, allowing a two-wires (high speed CAN see ISO 11898) or even one-wire communication (low speed CAN, see ISO 11519)
 - Each node resynchronizes itself on every falling edge occurring on the bus.
- CSMA/CA (Carrier Sense Multiple Access/Collision Avoidance)
 - Several nodes can request the bus simultaneously (CSMA).
 - When such a situation occurs, there is no loss of data and the message with the highest priority is immediately sent (CA).
- Multimaster capability (See “Arbitration Phase” on page 10)
 - Every CAN node in the network is able to transmit data.
 - The arbitration mechanism is decentralized.
- Object oriented communication
 - Each message on the bus carries its own identifier which is an 11-bit (or 29-bit) number. This field describes the content of the message. It is not an address.
 - Consequently, a transmitter doesn’t address data to a peer but simply broadcasts its data. Each node in the network picks off data from the bus when it recognizes an identifier that concerns it.

- Message prioritization
 - The identifier of a message also indicates the priority of its carrier. During the arbitration phase, a bitwise comparison of the different identifiers is performed. The message with the higher identifier being the more urgent, it wins the arbitration and is immediately transmitted.
- Error management system (See “Error Management” on page 11)
 - Detection: every node continuously monitors the bus, even if it is not concerned by the current transmission, to detect potential violations of the protocol.
 - Signalization: any node detecting an error, signals it to its peers and aborts the current transmission meanwhile. The sender automatically retries transmission within a certain amount of time. Thus, the consistency of data throughout the network is preserved.
 - Confinement: each node implements counters which are incremented (or decremented) after each detection of an error (or successful operation). A defective station can then switch itself off when its counters reach a certain value, and thus stop disturbing the bus operations.

1.1.2 CAN in the OSI reference model

The protocol occupies parts of the two lowest levels (the **physical** and **data link** layers) of the 7-level ISO/OSI (Open System Interconnection) telecommunications reference model.

Table 1. ISO/OSI Standard Telecommunication Layers

OSI Layer	OSI Model	CAN Protocol
7	Application	No (User defined)
6	Presentation	No (User defined)
5	Session	No (User defined)
4	Transport	No (User defined)
3	Network	No (User defined)
2	Data Link	Yes
1	Physical	Partly

In this reference model, the data link layer deals with physically passing data from one node to another. It defines arbitration, message framing, error management and transmission timing for example.

The physical layer deals with putting data on the physical network, and with taking it off. Consequently, it defines signal levels and timings, as well as the transmission support (wire types, connectors, etc.).

The CAN protocol splits the Data Link layer into **Object** and **Transfer** sublayers, corresponding to the ISO/OSI **Logical Link Control** and **Medium Access Control** sublayers. The Transfer layer is the interface between the user application and the CAN. The Object layer

manages frame shaping and acknowledgment mechanisms, bus arbitration and checks the formal correctness of the data transmitted and received.

The physical layer is only partly defined, and the user is free to choose the transmission medium for example.

Figure 1. Layered architecture of CAN (ISO 11898 definition)

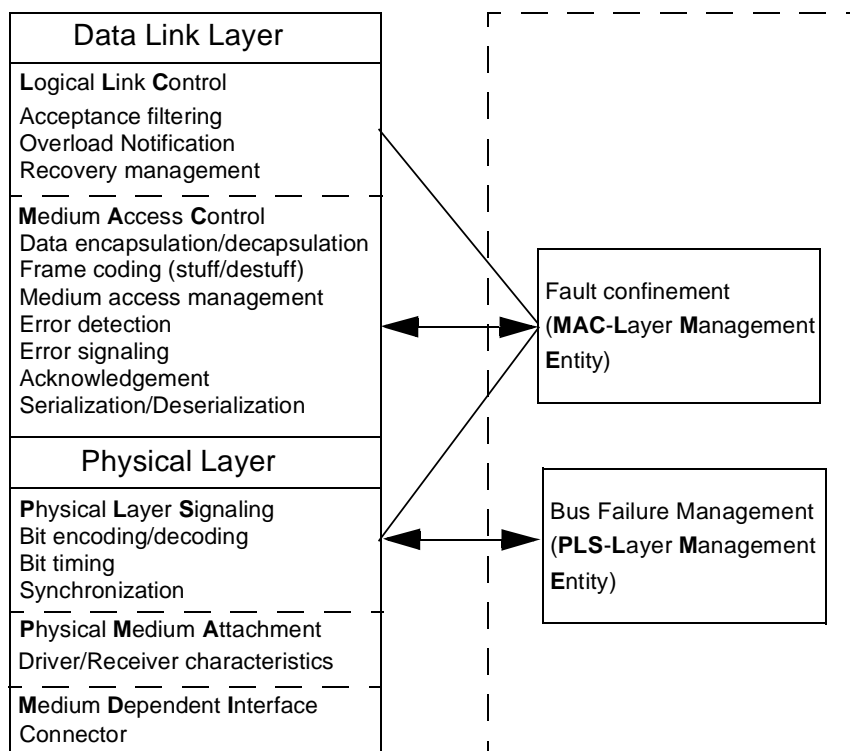

1.2 CAN FRAME

There are four different CAN frame types: **Data frame**, **Error frame**, **Remote frame** and **Overload frame**

There are also two versions of the CAN protocol: **2.0A** (or base format) and **2.0B** (or extended format). The 2.0B standard introduces an extended data frame with a longer identifier. Both frame types coexist on a CAN 2.0B bus, and its nodes must be at least able to recognize and acknowledge both.

We will only describe here the 2.0A format, or base format.

1.2.1 CAN Data Frame

The CAN Data frame is used for data transmission and contains the following fields:

- A start of frame field, consisting of one bit.
- A 12-bit **arbitration field**, including:
 - An 11-bit **identifier**

- A **RTR** bit used to differentiate data and remote frames. It is dominant in a data frame.
- A 6-bit **control field**, including:
 - A 4-bit **data length code** bits giving the size (in bytes) of the data field
 - 1 **IDentifier Extension (IDE)** bit (dominant for CAN 2.0A frame) and 1 bit reserved for further development.
- A **data field** of up to 8 bytes.
- A 16-bit long **CRC field**. The Cyclic Redundancy Check (CRC) is based on a BCH encoding.
- A 2-bit **acknowledgment** field. The transmitters sends it as all recessive. (See “Message Acknowledgement” on page 11)
- A 7-bit **end-of-frame** field.

The interframe space (or Intermission) is the minimum amount of time between two consecutive transmissions.

Figure 2. CAN Data Frame

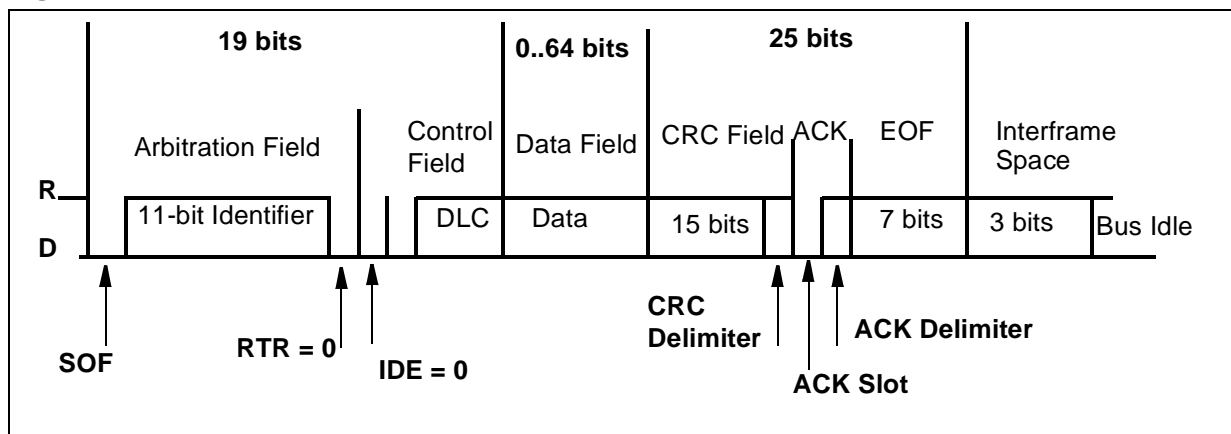

1.2.2 CAN Remote Frame

The CAN Remote frame is used to request data. This frame has the same overall constitution as the data frame. However, in this case, the Remote bit (RTR) is **recessive** and there is **no data field**.

Figure 3. CAN Remote Frame

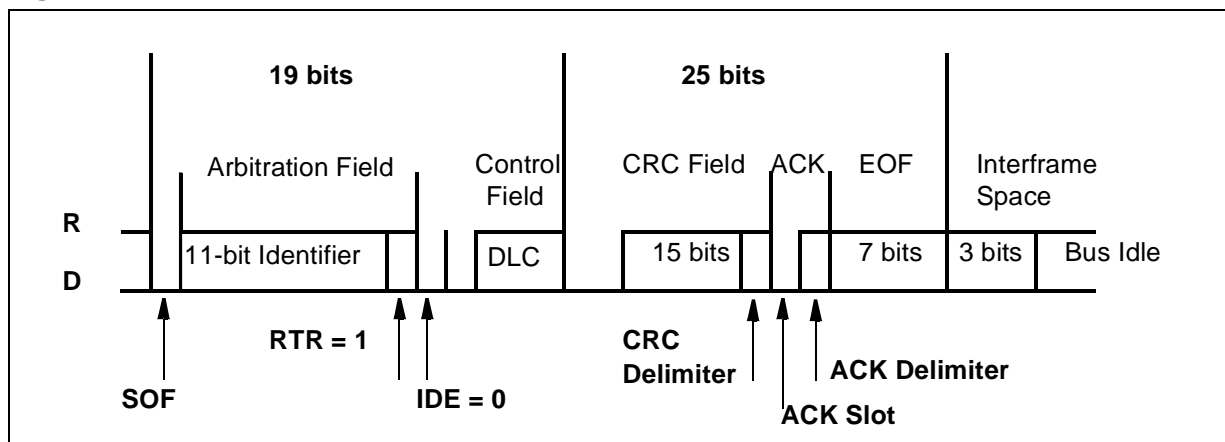

1.2.3 CAN Error Frame

The CAN Error frame is sent by a node as soon as it detects a protocol violation in the current operations on the bus. This frame is composed of 6 successive dominant bits (active error flag) or recessive (passive error flag), followed by 8 recessive **Frame Delimiter** bits. The current error state of the node sending the error frame (See Section 1.5 "Error Management") will determine whether it is an active frame (node in error active state) or a passive frame (node in error passive state).

1.2.4 CAN Overload Frame

The CAN Overload Frame can be sent during the interframe space to delay the next transmission on the bus. This frame has the same constitution as the active Error frame.

Figure 4. CAN Error/Overload Frame

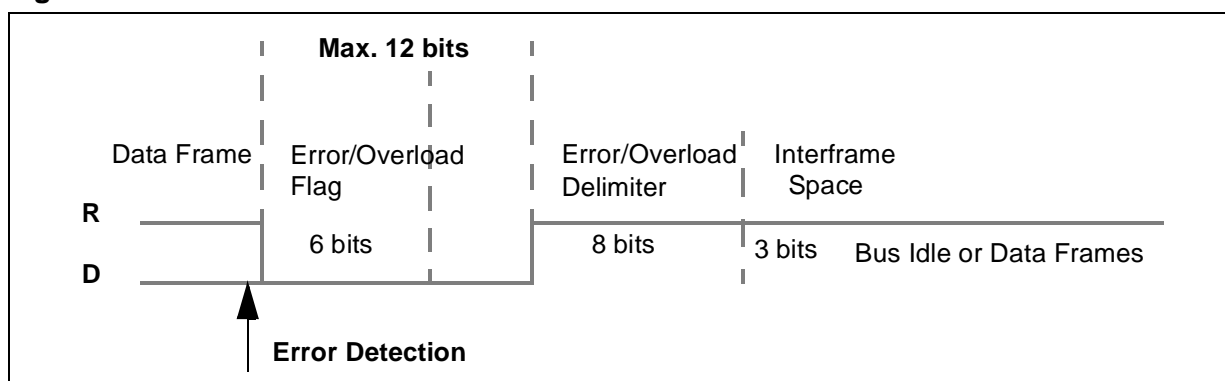

1.3 PHYSICAL REPRESENTATION OF DATA

The CAN data is encoded with **NRZ** (Non Return to Zero) code. The two logical levels used are named **dominant (0)** and **recessive (1)**. Because the CAN cells are connected on the bus according to the wired-AND principle, it follows that the default bus state is recessive, and that

transmission of a dominant bit forces this state to dominant, no matter how many other nodes are transmitting recessive bits.

1.3.1 Bit Stuffing

Once built, a frame is passed to the Transfer sub-layer, where the CRC is calculated. Then, **Stuffing Bits** are inserted in the frame. Each time five consecutive bits of the same logical level are detected, a bit of the opposite value is inserted. This is used to generate a minimum edge rate on the bus for resynchronisation purpose (See “Bit timing” on page 9).

Figure 5. Bit-stream NRZ Code & Bit Stuffing

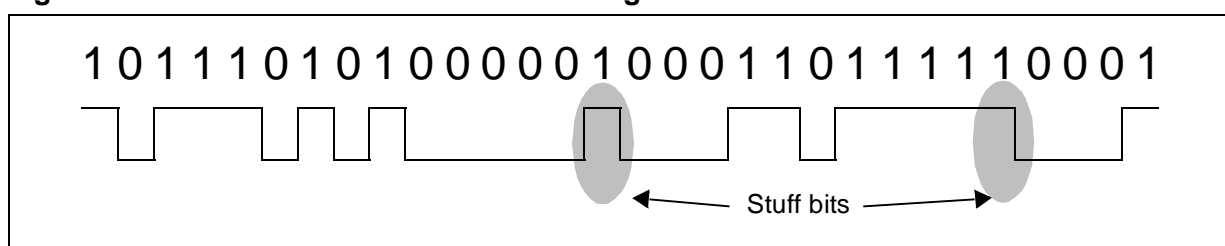

1.3.2 Bit timing

The CAN standard divides the bit time into four segments:

- A synchronisation segment (SYNC),
- A propagation segment (PROP),
- A phase buffer 1 segment (TSEG1),
- A phase buffer 2 segment (TSEG2),
- Each segment is divided into time quanta. The synchronisation segment lasts, by definition, 1 time quantum.

Figure 6. CAN Bit Segments

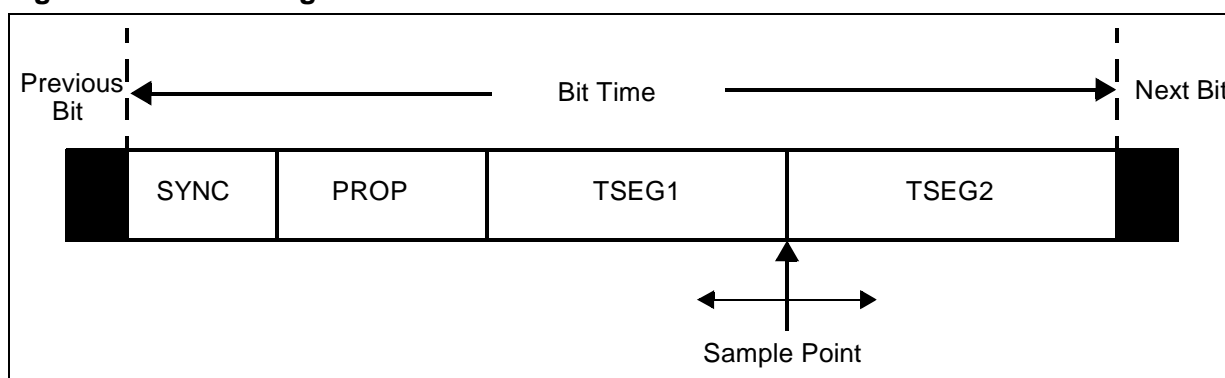

The CAN communication is asynchronous, i.e. no clock signal is sent together with data. Each node in the network maintains its own bit timing calculated from the internal clock of the device.

To deal with signal phase variations on the transmission line due mostly to desynchronization between clocks of bus participants, TSEG1 and TSEG2 are of variable length. A resynchronization of the local clock occurs on every recessive-to-dominant state change. If such a change arises before (or after) the SYNC segment expected by the cell, TSEG1 (or TSEG2) is lengthened (or shortened) to correct the detected variation. If the edges occur during the SYNC segment, the node assumes that it is synchronized.

The PROP segment takes into account the maximum propagation time of the signal on the network, ensuring that all the nodes sample the same bit at the same time.

The sampling point of the bit takes place between TSEG1 and TSEG2.

1.4 ARBITRATION PHASE

1.4.1 Arbitration Phase

All the cells connected on the CAN network are likely to transmit a message at any time. A cell can initiate a transmission only when the bus is idle. On transmission of a message, a cell simultaneously monitors the state of the bus to detect potential problems.

If the bus is idle, any cell that is ready for transmission begins to send its data. The other nodes listen.

If the bus is already in use when a cell requests it, the cell waits until the end of the current transmission. Then, all the nodes that are ready to transmit begin their transmission. If a dominant and a recessive bit are sent in the meantime, the first one erases the second. This causes the cell that is sending the recessive bit to lose the arbitration and switch to Reception mode. This way, messages with the highest identifiers are sent before the others. This mechanism also prevents collisions occurring on the bus, which saves bandwidth. This is referred to as non-destructive bitwise arbitration.

Figure 7. Arbitration example: node 1 wins

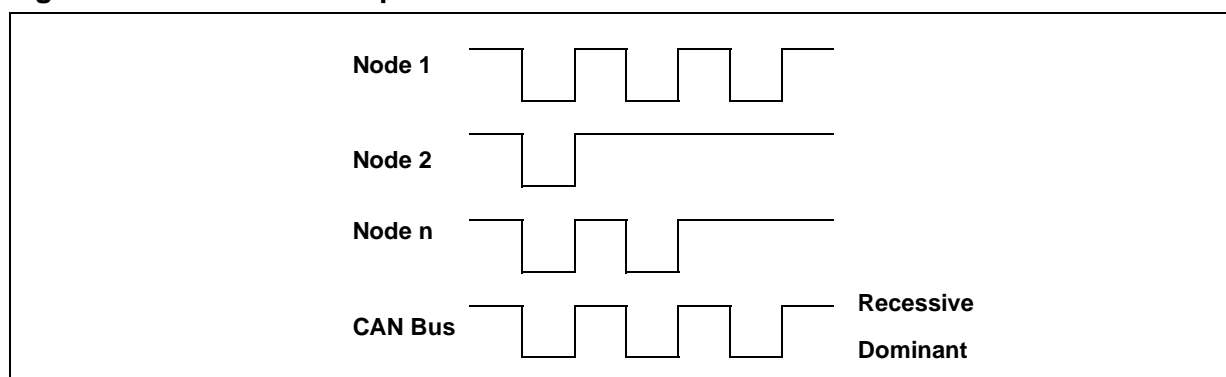

1.4.2 Message Acknowledgement

Any cell having received a message correctly, regardless of the result of the acceptance test, must acknowledge it by sending a dominant bit during the ACK slot of the current frame, thus overwriting the recessive bit sent by the current transmitter.

1.5 ERROR MANAGEMENT

The Error Management System of the CAN protocol is proof of the protocol's robustness. This system provides a way to automatically distinguish permanent failures from sporadic errors. It can lead to self-disconnection of a failing node from the bus. This feature is named **Error Confinement**. An error is defined as a violation of one of the protocol's rules. It can happen after one of following events:

- **Bit error:** A transmitter detects a difference between the actual bus state and what it sends.
- **Acknowledgement error:** A frame is not acknowledged (ACK slot recessive).
- **Stuffing error:** More than five identical bits were received consecutively.
- **CRC error:** The CRC received does not match the calculated CRC.
- **Format error:** One of the fixed-format fields (CRC delimiter, ACK delimiter, End Of Frame) does not have the expected format.

An Error frame is immediately sent by all the cells that have detected an error on the bus. Note that the Error frame does not yield to the Stuffing rule. Upon reception of this frame, all cells in the network detect a Stuffing error and react by sending an Error frame. The dominant state of the bus caused by the occurrence of an error can last at most 12 bits (case when a node detects the error only at the end of the error flag).

The Error Confinement system is based on two counters:

- A TransmissionError counter (TEC)
- A ReceptionError Counter (REC)

The rules handling the counters are basically the following:

- When an emitting node detects an error, it increments its TEC and sends an error frame.
- When a receiving node detects an error it increments its REC and sends an error frame.
- When a transmission is successful, the TEC counter is decremented.
- When a reception is successful, the REC counter is decremented.

Note: The complete set of rules is quite complicated taking into account the possibility of receiving overload frames, etc. Consequently, it's beyond the scope of this document. This document describes the basic reactions of the cell. For more information, refer to the original Robert Bosch GmbH document or to the ISO 11898 norm.

The behaviour of the cell concerning the state of the counters is shown in the following diagram.

Figure 8. CAN Error States

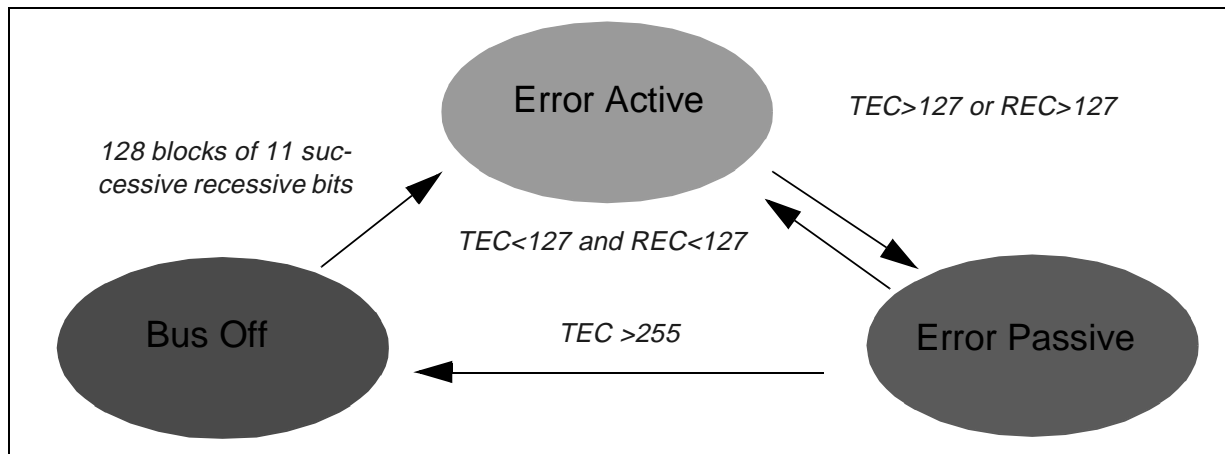

When both counters contain values between 0 and 127, the CAN node is in **Error Active state**, which means that it can send and receive normally. If it detects an error, it will send Active Error flags.

When one of the two counters reaches a value between 128 and 255, the node is in **Error Passive state**. It will go on receiving and sending normally but will only be authorized to send Passive Error flags. Therefore, if this node causes trouble by sending unjustified Error frames, it will not disturb the network for too long.

When one of the counters reaches a value over 255 (i.e. it overflows), the CAN node enters **Bus Off state**. It is then physically disconnected from the bus. It can go back to Active mode if it successfully detects 128x11 consecutive recessive bits on the bus.

1.6 ST7 PCAN PERIPHERAL

1.6.1 Main Features

The ST7 pCAN peripheral implements a CAN 2.0B passive protocol. This means that extended frames are recognized and acknowledged, but cannot be saved nor processed by the microcontroller.

- The pCAN peripheral is based on **three 10-byte hardware buffers** that can be used either for transmission or reception. They are prioritized in the increasing priority order 1 to 3 for transmission and 3 to 1 for reception. Each buffer has a control register indicating if a job is pending, if new data has been received or if the buffer is currently being written/read. A bit in this register is used to lock the buffer for transmission (See ST72511 datasheet p.116).
- The baud rate is programmable **up to 1 Mbps**. The length of the bit synchronisation fields is also programmable. The baud rate is configured by setting three values: the size of time quanta (in clock ticks) and the length of the two synchronization segments (in time quanta). See ST72511 datasheet p.114, **Baud Rate Prescaler Register** and **Bit Timing Register**.

- Two **11-bit filters** and two **11-bit masks** are used for hardware filtering with identifier/identifier-range definition. The masks define which bits of the filters are to be ignored and which are to be tested. Any message whose identifier does not match will not be saved in the buffers.
- The cell automatically enters Low Power mode after the reception of 20 recessive bits, or Standby state on command.
- The pCAN peripheral can **wake-up** the ST7 microcontroller **from HALT mode**. See Section 2.1.3.2 "Waking-up from HALT Mode" to learn how.
- The **CAN Error Confinement** feature, as defined by the CAN protocol, is **fully implemented**, with read-only access to the counters and maskable interrupts on state changes. Once in Bus Off state, the cell automatically returns to Bus Active state if it has detected 128x11 recessive bits on the bus (see Section 2.1.3.1 "Controlling Status Changes"). See note on Section 2.1.3.2 "Waking-up from HALT Mode" to see how the driver can provide you with full control over the bus-off to bus-active transition.
- The three Send/Receive buffers, filters, masks and counters are **mapped at a unique address space**, allowing efficient software access.

1.6.2 Cell Behaviour

In Standby state, the node monitors the bus in order to detect a dominant pulse that could generate an interrupt (See ST72511 datasheet p.112, Interrupt Control Register, SCIE bit).

When the RUN bit of the Control Status Register is set (See ST72511 datasheet p.113), the cell leaves *standby* mode. It then enters *resynchronization* mode before it really starts running. If the WKPS bit of the Control/Status Register is set, then the cell will send a dominant pulse when it wakes up. You can choose between two resynchronization durations: 11 recessive bits if the FSYN bit of the CSR is set or 128*11 recessive bits if not (See ST72511 datasheet p.113).

If the cell resynchronizes after leaving bus-off state, it will wait 128*11 recessive bits, whatever the value of FSYN may be.

To send data, a buffer has to be selected first by writing to the Page Selection Register (See datasheet p. 114). Then it has to be locked for transmission by setting the LOCK bit in the Buffer Control/Status Register (See datasheet p.116: LOCK bit and RDY bit). Then data can be written in the buffer registers: identifier, data length code, data bytes. Writing in the seventh data register starts transmission.

Received data is automatically stored in one of the buffers configured for reception (LOCK bit reset) each time a message identifier matches the hardware filters of the pCAN cell, and provided that this buffer is marked as free (RDY bit reset. See datasheet p.116: LOCK bit and RDY bit). The masks/filters can be configured through the Filter/Mask High/Low Registers (See datasheet p.117).

ST7 pCAN PERIPHERAL DRIVER

Any event (successful transmission, data reception, error, state change, overrun) can generate a maskable interrupt. The Interrupt Control Register (see datasheet p.112) allows you to set/reset these masks. Note that each buffer has its own reception interrupt, allowing the data to be saved rapidly.

Note: For further, more detailed explanations, please read the ST72511R/ST72512R/ST72532R Datasheet, downloadable from the ST web site, <http://mcu.st.com>.

Figure 9. ST7 pCAN State Diagram

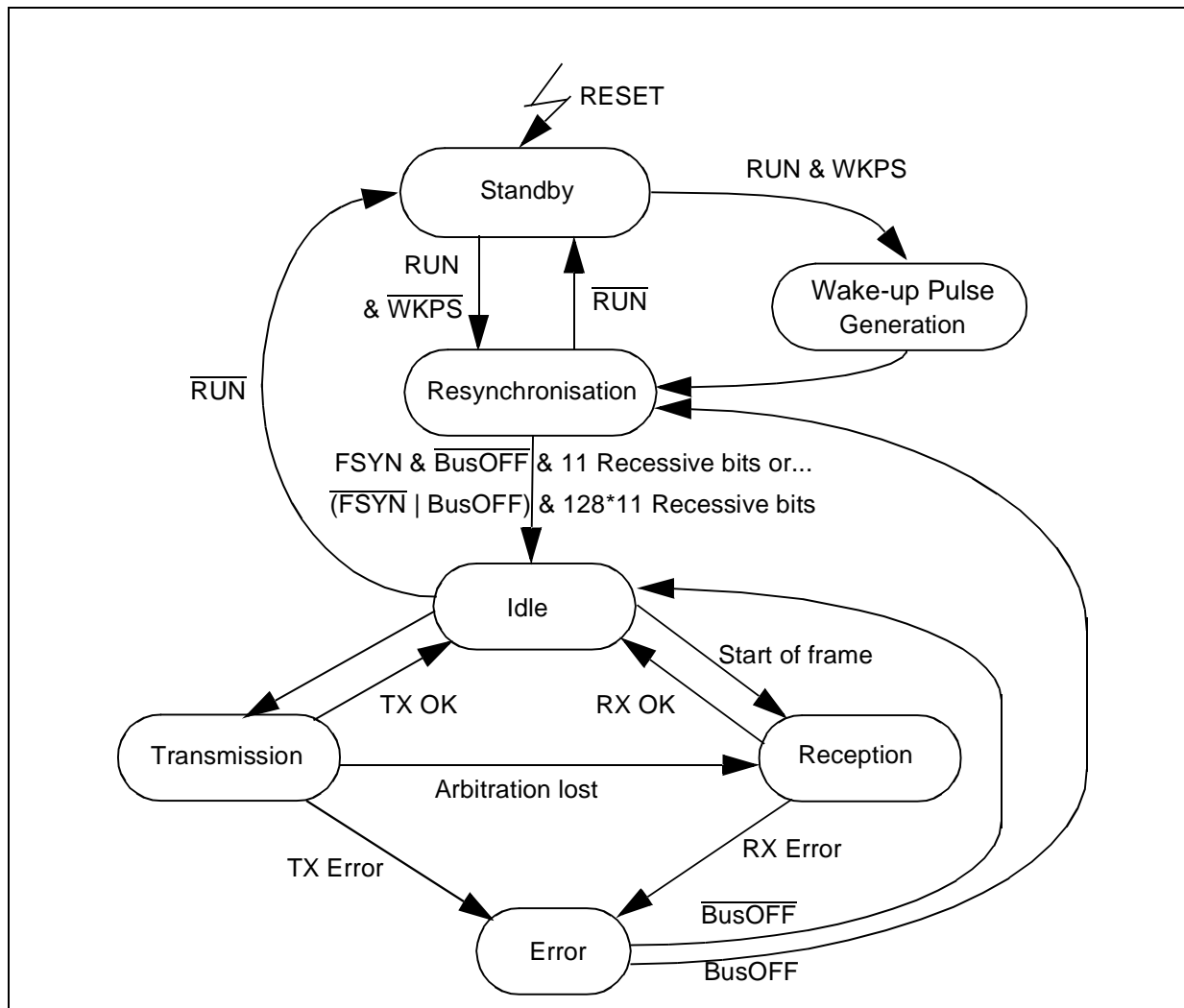

2 CAN DRIVER

To quickly start developing your own CAN applications using the ST7 pCAN peripheral, STMicroelectronics provides you with a driver. The source code (`can.h` and `can.c`) is given as an example, and can therefore be used as provided or be modified to fit specific needs.

There are two customization files which make the driver's functionality flexible and able to meet a wide range of needs.

The entire processing is interrupt driven, so no polling is required. The application is notified of CAN events through function calls from the interrupt routine.

To immediately use the driver, without modifying its structure, see Section 2.2 "How to Use the CAN Driver: A Demo Application".

The following sections will explain the details of the driver architecture and describe all the functions and data types implemented in the software.

2.1 USER INTERFACE

2.1.1 Files Furnished

The driver consists of five files:

- **can.c**. Driver function definitions and internal data types. This file may not be modified.
- **can.h**. Header file of `can.c`. This file may not be modified.
- **can_hr.h**. Hardware description (register mapping of the ST7 MCU memory space). This file is hardware dependent and must not be modified.
- **can_custom.c**. Frames of customization functions. They are called (some optionally) by the driver to notify the application of events when some user-specific processing is required (for example on reception of data). This file has to be completed by the user.
- **can_custom.h**. Contains a pre-processor directive list (*#define* types) which allows user customizations to be taken into account at compilation time. This file has to be modified by the user.

2.1.2 Architecture

The cell is statically configured with one transmission buffer and two reception buffers, which reduces the need for processor responsiveness in reception.

For the same purpose, a 3-message deep transmission FIFO is implemented. It is not accessible by the user, and is automatically managed by the software.

The entire processing is interrupt driven. The user can choose which interrupts are to be taken into account and which are not, due to the compilation options in `can_custom.h`. Some interrupts request an immediate answer from the application, e.g. a reception event. To avoid having the user modify the interrupt routine (in `can.c`), the routine calls one of the notification

functions defined in `can_custom.c` on certain events. The user only has to enter these functions according to his needs before compiling the software.

2.1.3 Principle of Use

During compilation, the values of the hardware control registers are calculated by the preprocessor according to the compilation options selected in `can_custom.h`.

If the software filtering feature is enabled, the values of accepted identifiers have to be entered by the user as a list in `can_custom.h` (See “Filtering” on page 29)

The functions in `can.c` are compiled or not, according to the selected `#define` directives. (The unwanted ones are simply left as comments).

Figure 10. Driver Customization System

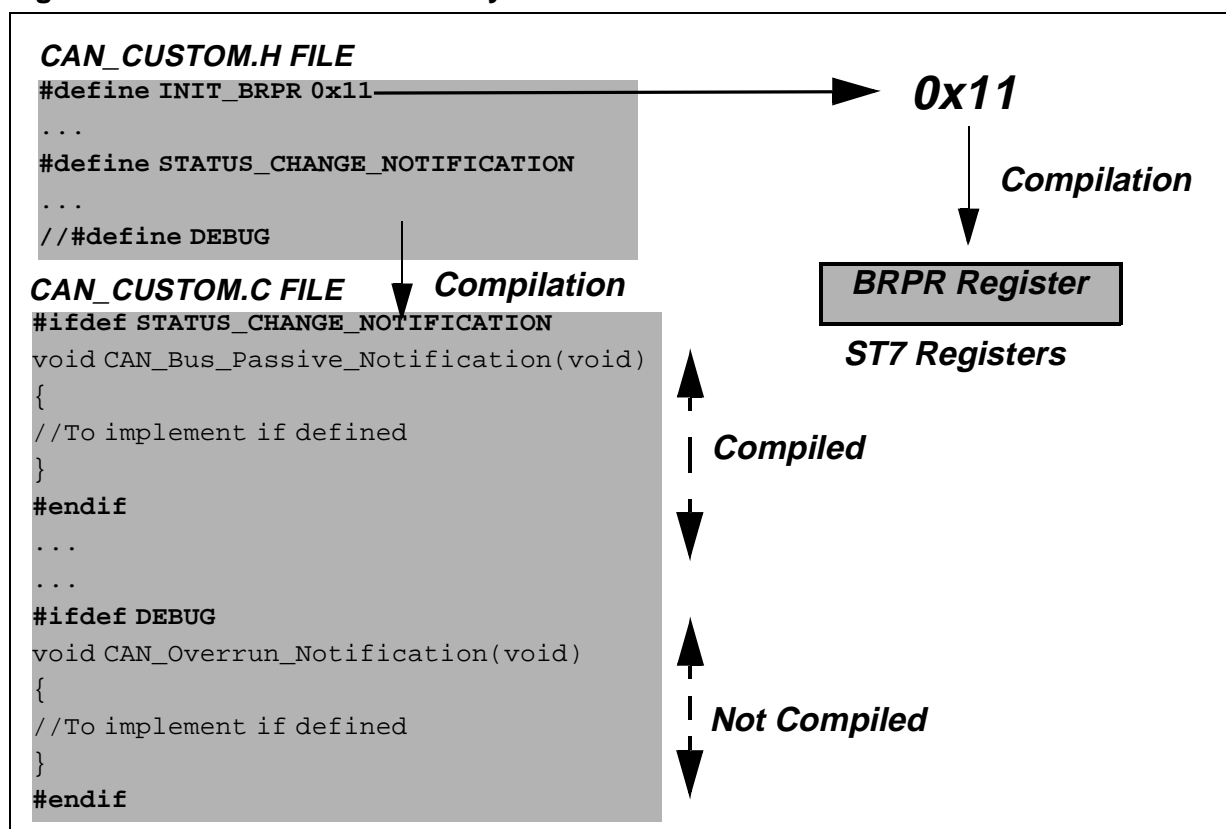

During the first initialization (performed using the `CAN_First_Init` function), the peripheral's registers are written with the values defined at compilation time, the transmission FIFO is initialized and the cell starts (a wake up by bus can be chosen).

Then:

- The `CAN_Transmit_Request` function initiates a transmission which begins with an in-queuing of the message to be sent. Then, hardware buffer no.1 (the static transmission buffer) is filled according to hardware requirements. (See Section 1.6.2 "Cell Behaviour").

- The *CAN_Switch_Off* and *CAN_Sleep* functions are used to switch the cell to Standby mode. The first function kills any pending jobs and erases all data in the reception buffers, even if the data is unread. The second function is executed the same way as long as no work is in progress, the transmission FIFO is empty and all reception buffers have already been read. These two functions also define the way the cell will be woken-up: either by bus or by software (by enabling or disabling the corresponding interrupt). They can help you to manage status changes by controlling the transition between Bus Off and Bus Active states (See Section 2.1.3.1 "Controlling Status Changes").
- *CAN_Switch_On* resets the cell and returns to RUN mode. It can also place the cell in a state waiting for a dominant pulse to be woken-up.
- *CAN_Get_Status* returns the current status of the peripheral (run, standby, error passive...)
- *CAN_Get_TEC* returns the current content of the transmission error counter.
- *CAN_Get_REC* returns the current content of the reception error counter.

2.1.3.1 Controlling Status Changes

Your application can be notified by the driver when the error state of the cell changes. (See "Compilation Options" on page 25). If you don't want the microcontroller to directly resynchronize after leaving bus-off state for example, you can call the *CAN_Switch_Off* function from inside of the *CAN_Bus_Off_Notification* function (See "Can_custom.c File" on page 26), then perform any operations you want before calling the *CAN_Switch_On* function to restart the peripheral.

2.1.3.2 Waking-up from HALT Mode

If you want to switch the ST7 to HALT mode and have it woken-up by the CAN, the correct interrupt routine must be enabled. Before switching to HALT mode, call the *CAN_Sleep* or *CAN_Switch_Off* function with the *BUS_WAKEUP* parameter that is used to enable the CAN interrupt on the bus dominant state while in Standby state.

Then, enter the *CAN_Dominant_Bit_Reception_Notification* function to customize the waking up of the microcontroller.

Note: See ST72511 datasheet p.37 for more information about HALT mode.

2.1.4 Interrupts (ITs)

Once the interrupt routine is entered, the first thing you want to know is "What triggered the event?" Priority is then given to reception if more than one IT has occurred simultaneously, unless the *DEBUG* compilation option was set. In this case, the Error ITs are processed first.

- In the event of a Transmission IT, the driver tries to send the following message in the queue, if it's not empty. The driver then notifies the application of the event before leaving the routine.

Figure 11. Transmission IT Procedure

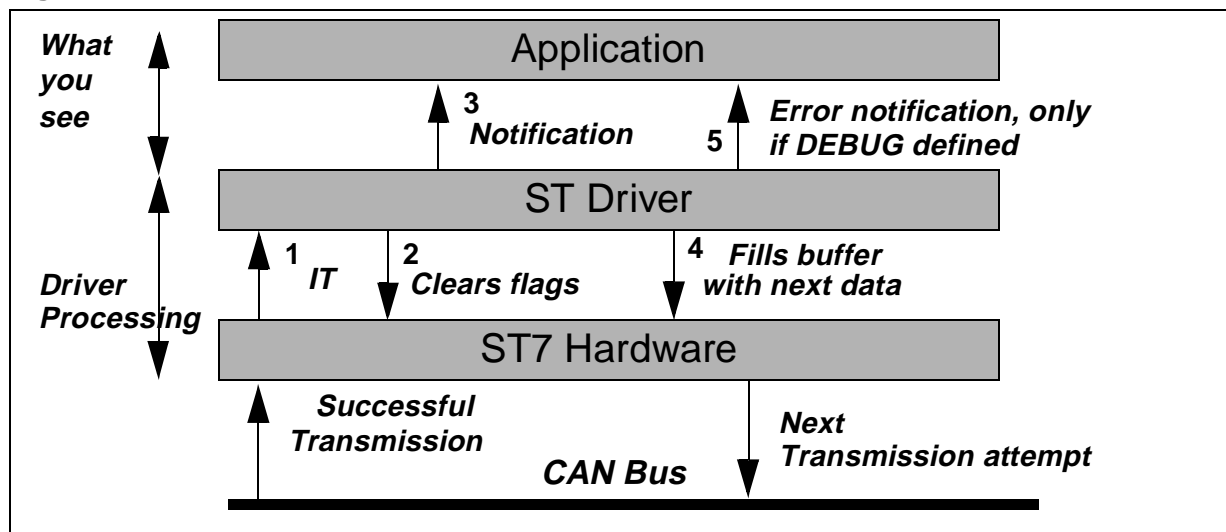

– In the event of a reception IT, after having found which buffer is involved, the driver performs an optional software filtering, then notifies the application. If the cell received a remote frame, the CAN_Remote_Reception_Notification function is called. Otherwise, if the cell received data, the CAN_Request_Buffer function is called to request a buffer from your application. After the buffer is filled, the driver calls the CAN_Data_Reception_Notification function to notify you that the data is ready. If the DEBUG option is set, the CAN_Reception_Status function is called just before leaving the IT routine, which passes the status of the reception processing procedure (Error, Success...) as a parameter. This is used to detect the causes of any problems. See “Can_custom.h File” on page 24 for more information about notification routines.

Figure 12. Reception IT Procedure

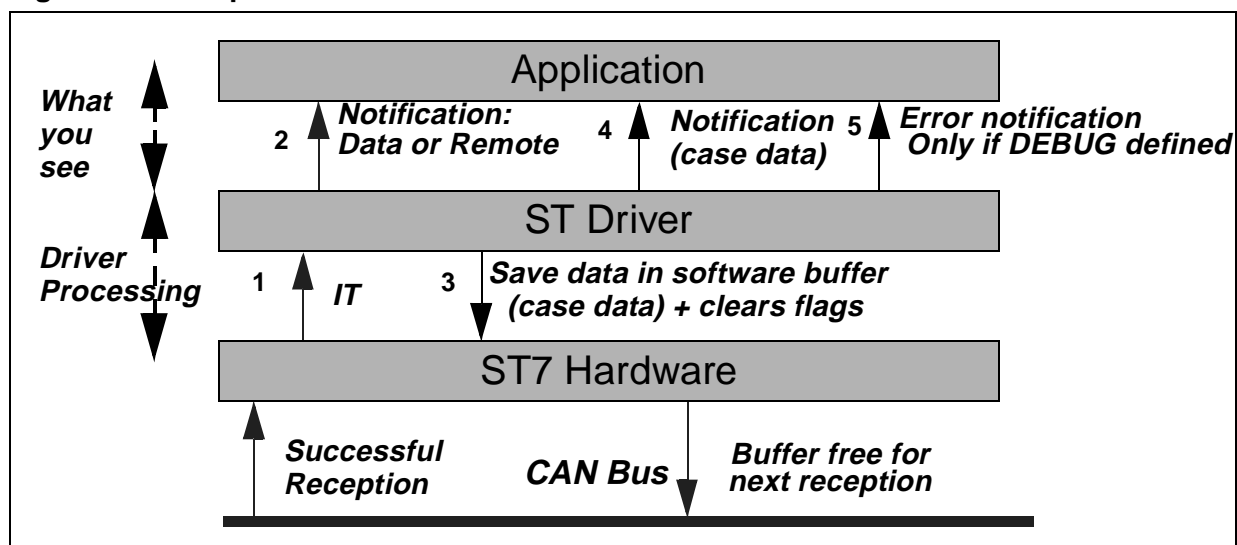

- Error ITs are only processed if the DEBUG option was chosen in `can_custom.h`. Then, the application is notified of any other events through function calls. (Functions entered in `can_custom.c`).

2.1.5 User Interface Description

This section describes the user interface in a “black-box” way. The parameters and the return values of the function declared in `can.h` and `can_custom.h` are described in this section. For a complete description of the algorithms and internal data type variables, please see Section 3 “Detailed Description”.

2.1.5.1 Data-type Variables

CAN_Buffer -type variables

```
typedef struct CAN_Buffer{
    u16msg_identifier;
    CAN_Data_Size data_size;
    u8 CAN_msg_data[CAN_MAX_DATA_SIZE];
    CAN_Bool buffer_rw;
    CAN_Bool buffer_free;
}CAN_Buffer;
```

Software representation of CAN data. The translation into hardware buffers is performed by the driver.

A variable of this data-type must be passed to the driver each time it is requested by the `CAN_Request_Buffer` notification function (See “Functions called unconditionally” on page 26). Otherwise, data in the hardware buffer will be lost.

A pointer to this structure is also used as parameter of the `CAN_Transmit_Request` function (See “Functions” on page 21).

- *msg_identifier*: 2 bytes field containing the identifier of the CAN message. The identifier is stored in the 12 most significant bits. The 4 least significant bits MUST be zero. The u16 type means 2 bytes unsigned variable and is defined in `lib.h`.
- *data_size*: 1 byte field containing the length of the data in the message (in bytes). The `CAN_Data_Size` type is an enum type (See below for its description).
- *CAN_msg_data*: array of 8 bytes containing the data to be sent. The u8u16 type means 1 byte unsigned variable and is defined in `lib.h`.
- *buffer_rw*: this boolean variable is to be used as a flag to prevent simultaneous writing/reading on the structure. It is checked and modified by the driver each time an operation is being performed on the buffer. If CTRUE, the structure will not be read or written. If CFALSE, it can be used. Always check/modify this variable in your application for this purpose.
- *buffer_free*: boolean variable used to mark if the data in the buffer can be overwritten or not. It has to be used as the security by the user’s application. If CFALSE, the driver will refuse to perform any write operation on the data in the structure and return an error code.

If CTRUE, the data can be modified. Take care to check and/or initialize it before passing a buffer to the driver.

Init_Data -type variables

```
typedef struct {  
    u8 brpr_init;  
    u8 btr_init;  
    u8 fhr1_init;  
    u8 flr1_init;  
    u8 mhr1_init;  
    u8 mlr1_init;  
    u8 fhr0_init;  
    u8 flr0_init;  
    u8 mhr0_init;  
    u8 mlr0_init;  
    u8 }Init_Data;
```

This structure contains the value of registers that can be reinitialized when switching on the cell after a passage in Standby state (see Section 2.1.5.2 "Functions", CAN_Switch_On).

It is used for hardware initialization.

- *brpr_init*: value of the CANBRPR register (set length of a CAN time quantum in number of CPU clock ticks). See “Bit timing” on page 9.
- *btr_init*: value of the CANBTR register (length of both time segments 1 and 2 in number of time quanta). See “Bit timing” on page 9.
- *fhr1_init*: value of Filter 1 High Register.
- *flr1_init*: value of the Filter1 Low Register.
- *mhr1_init*: value of the Mask 1 High Register.
- *mlr1_init*: value of the Mask 1 Low Register.
- *fhr0_init*: value of Filter 0High Register.
- *flr0_init*: value of the Filter 0 Low Register.
- *mhr0_init*: value of the Mask 0High Register.
- *mlr0_init*: value of the Mask 0Low Register.

Enum -type variables

The names of the variables are in principle self-explanatory.

```
typedef enum  
{DLC0, DLC1, DLC2, DLC3, DLC4, DLC5, DLC6, DLC7, DLC8, REMOTE_FRAME}CAN_Data_Size;
```

Possible values of the CAN_Message data_size field (See “CAN_Buffer -type variables” on page 19)

```
typedef enum
```

```
{CAN_RUN, CAN_STANDBY, CAN_BUS_ACTIVE, CAN_BUS_PASSIVE, CAN_BUS_OFF}CAN_Status;
```

Describes the different states of the cell.

```
typedef enum {CFALSE=0, CTRUE=1}CAN_Bool;
```

Custom Boolean type variable.

```
typedef enum {BUS_WAKEUP, SOFT_WAKEUP}WakeUp_Cause;
```

Possible parameters of the CAN_Sleep and CAN_Switch_Off functions. (See Section 2.1.5.2 "Functions".)

```
typedef
enum{CAN_SLEEP_ERROR, CAN_SLEEP_SUCCESS, CAN_SWITCH_ON_SUCCES, CAN_SWITCH_ON_FA
ILURE}CAN_Switch_Error;
```

Possible values returned by CAN_Sleep, CAN_Switch_Off and CAN_Switch_On functions (See Section 2.1.5.2 "Functions")

```
typedef enum {CAN_INIT_SUCCESS, CAN_INIT_FAILURE}CAN_Init_Error;
```

Possible values returned by CAN_First_Init function (See Section 2.1.5.2 "Functions")

```
typedef enum
{CAN_TRANSMIT_SUCCESS, CAN_TRANSMIT_FAILURE, CAN_TRANSMIT_NO_MSG, CAN_FIFO_FULL
, CAN_TRANSMIT_BUFFER_FULL, CAN_TRANSMISSION_ERROR_IT}CAN_Transmit_Error;
```

Error codes used in Transmission functions.(See Section 2.1.5.2 "Functions")

```
typedef enum
{CAN_RECEIVE_SUCCESS, CAN_RECEIVE_REMOTE, CAN_ILLEGAL_IDENTIFIER, CAN_FILTERING
_FAILURE, CAN_RECEIVE_FAILURE, CAN_BUFFER_IN_USE, CAN_NO_BUFFER, CAN_RCV_BUFFER_
NOT_READY}CAN_Receive_Error;
```

Error codes used in Reception functions. (See Section 3.2.2 "Internal Routines").

Note: With some compilers, an option is used to define the size, in bytes, of enum-type variables. We recommend selecting 1 byte, if possible, to save memory space.

You can see in which case the different error codes are returned by the functions by studying the flow charts in Section 3.2.2 "Internal Routines" for internal functions and Section 3.1 "User interface functions" for user interface functions.

You also find this information in the arrays of Section 2.1.5.2 "Functions" for user-interface routines and Section 3.2.2 "Internal Routines" for internal routines.

2.1.5.2 Functions

CAN_Init_Error CAN_First_Init(void):

Input	--
Output	Error status

ST7 pCAN PERIPHERAL DRIVER

Description	CAN Cell Power-on initialization routine. During its execution, all registers are initialized with values entered in can_custom.h or calculated from the compilation options chosen It initializes the transmission queue. This function must be called in the main routine prior to any use of the CAN cell. Possible return values: CAN_INIT_FAILURE and CAN_INIT_SUCCESS.
Comments	Calls CAN_Init() (See Section 3.2.2 "Internal Routines")

void CAN_It_Dis(void):

Input	--
Output	--
Description	Disables all CAN interrupts.
Comments	--

CAN_Status CAN_Get_Status (void):

Input	--
Output	Current status of the cell
Description	Retrieves the current status of the CAN cell. Possible return values: CAN_STANDBY, CAN_BUS_PASSIVE, CAN_BUS_OFF and CAN_BUS_ACTIVE following the current state of the cell.
Comments	Useful if the STATUS_CHANGE_NOTIFICATION option is enabled in can_custom.h

u8 CAN_Get_TEC(void):

Input	--
Output	Value of the TECR register (Transmission Error Counter)
Description	Returns the value of the TECR
Comments	--

u8 CAN_Get_REC(void):

Input	--
Output	Value of the RECR register (Reception Error Counter)
Description	Returns the value of the RECR
Comments	--

CAN_Switch_Error CAN_Switch_Off(WakeUp_Cause):

Input	Chip Wake-up function: BUS_WAKEUP or SOFT_WAKEUP
Output	Error status

Description	<p>Puts the CAN node into Standby state.</p> <p>This function aborts any pending transmissions and does not wait for the reception buffers to be read. Then, it resets the driver in the same state as after power-on initialization.</p> <p>If BUS_WAKEUP is selected, the next dominant bit detected on the bus will restart the cell. If SOFT_WAKEUP is selected, the cell will not take the bus state into account. It can only be woken up by the CAN_Switch_On function.</p> <p>Possible return value: CAN_SLEEP_SUCCESS or CAN_FATAL_ERROR (if the RUN bit fails to reset after a time out or if the CAN_Clean function fails).</p> <p>There is a time out mechanism implemented in this function (about 30ms), waiting for the RUN bit to be actually reset. So if your application uses the watchdog REFRESH IT BEFORE calling the function</p>
Comments	Calls CAN_Clean (See Section 3.2.2 "Internal Routines".)

CAN_Switch_Error CAN_Sleep (WakeUp_Cause):

Input	Chip Wake-up function: BUS_WAKEUP or SOFT_WAKEUP
Output	Error status
Description	<p>Puts the CAN node into Standby state.</p> <p>Returns CAN_SLEEP_ERROR if a transmission request is pending, or if a hardware reception buffer is still unsaved.</p> <p>Possible return values: CAN_SLEEP_ERROR if there are jobs pending in the hardware registers, CAN_FATAL_ERROR if the RUN bit fails to reset after a time out, or CAN_SLEEP_SUCCESS</p>
Comments	This function will not reset the CAN node.

CAN_Switch_Error CAN_Switch_On(Init_Data_Ptr,CAN_Bool):

Input	Pointer on an Init_Data structure (See Section 2.1.5.1 "Data-type Variables"), Boolean (CTRUE, CFALSE)
Output	Error status
Description	<p>Puts the CAN node into Active state</p> <p>The Boolean is used to transmit a dominant pulse (CTRUE) or not (CFALSE) upon wake-up.</p> <p>The bit timing and the mask/filter parameters can be reinitialized in this function. In most cases, the cell will be initialized the same way as in the Power-on sequence. So, you can re-use the first_init_data structure is declared in can.h.</p> <p>Possible return values: SWITCH_ON_SUCCES and SWITCH_ON_FAILURE.</p>
Comments	Calls CAN_Init (See Section 3.2.2 "Internal Routines").

CAN_Transmit_Error CAN_Transmit_Request(CAN_Buffer*):

Input	Pointer to the CAN message to be sent
Output	Error status

Description	<p>Puts a buffer into the transmission queue, and may request an immediate transmission if the queue is empty.</p> <p>The <code>buffer_rw</code> field has to be <code>CFALSE</code> before passing it to the function. It is immediately marked as <code>CTRUE</code> after entering the routine. In case of an error, during the execution, this parameter is reset to <code>CFALSE</code> before exiting. Else it is only reset by <code>CAN_Fill_Transmission_Buffer</code> (See Section 3.2.2 "Internal Routines").</p> <p>Possible return values:</p> <p><code>CAN_TRANSMIT_FAILURE</code> if the cell is in stand-by, <code>CAN_FIFO_FULL</code> if the 3 messages deep FIFO is full, <code>CAN_TRANSMIT_FATAL</code> if <code>CAN_Fill_Transmission_Buffer</code> fails, or <code>CAN_TRANSMIT_SUCCESS</code> otherwise.</p>
Comments	<p>This function MUST NOT be interrupted, so protect it with <code>SIM</code> and <code>RIM</code> statements when used OUTSIDE the notification functions of <code>CAN_custom.c!</code></p> <p>Calls <code>CAN_Init_Queue</code> and <code>CAN_Fill_Transmission_Buffer</code> (See Section 3.2.2 "Internal Routines")</p>

2.1.5.3 Constants

Those constants are defined internally, but are made visible to the user because they may be useful.

```
extern const Init_Data first_init_data
```

This is the initialization data structure that is used on power-on. It is made visible to allow you to pass it to the `CAN_Switch_On` function when you do not want to modify the parameters it contains. (See Section 2.1.5.1 "Data-type Variables")

```
extern const ul6 i_filters[];
```

This is the array of filters used to perform software filtering on incoming messages. The maximum number of identifiers stored is 127 (See "Filtering" on page 29). It is made visible in case you would like to link the behaviour of your application upon reception of a message with the offset of the identifier in the array (managing an array of pointers to functions for example). One can of course imagine other applications.

2.1.5.4 Can_custom.h File

The preprocessor directives used to configure the hardware and to customize the driver are located in this file.

Cell Configuration Values

```
#define INIT_BRPR 0x00
#define INIT_BTR 0x00
```

These values are used to initialize bit timing registers. (See Section 2.2.2.1 "Bit Timing").

```
/*Masks & filters*/
#define INIT_FHR0 0x00
```

```
#define INIT_FLR0 0x00
#define INIT_MHR0 0x00
#define INIT_MLR0 0x00
#define INIT_FHR1 0x00
#define INIT_FLR1 0x00
#define INIT_MHR1 0x00
#define INIT_MLR1 0x00
```

These values are used to initialize hardware filters and masks. (See “Filtering” on page 29).

Compilation Options

```
//Start options
//#define WAKE_UP_PULSE
#define RUN_ON_START_UP
```

You may decide whether or not to include these options in the code.

If enabled:

- WAKE_UP_PULSE enables the cell to send a dominant bit when leaving Standby mode.
- RUN_ON_START_UP starts the cell in the Initialization function `CAN_First_Init`. If not enabled, make sure that a dominant bit detected on the bus can make the cell start. To do this, complete the `CAN_Dominant_Bit_Reception_Notification()` function in `can_custom.c` in calling `CAN_Switch_On`.

```
//#define FILTERS_ENABLED
//#define INIT_FILTERS { }
```

These options are used for software filtering.

Select both of them if you want to use the feature.

If selected, enter the list of identifiers to be accepted between the curly braces as shown in “Software Filter Configuration” on page 30.

Enabling one of the following options implies modifying the corresponding function in the `can_custom.c` file:

```
//#define STATUS_CHANGE_NOTIFICATION
```

This option is used to monitor status changes (active/passive/bus-off). Setting this option will change the priority order in which the interrupts are taken into account. The interrupts concerning status change will be checked first, before considering reception and transmission interrupts. It will also allow compilation of the corresponding notification functions (`CAN_Bus_Passive_Notification`, `CAN_Bus_Active_Notification`, `CAN_Bus_Off_Notification`).

To use the Error Notification functions (called when an Error IT is received), enable:

```
//#define DEBUG
```

If DEBUG is defined, you can then chose to add the following options:

```
//#define GENERAL_RECEPTION_ERROR
```

All reception errors trigger an interrupt. You CANNOT use this option and the *Status Change Notification* function together because both use the same IT flag. This option does not exclude the bus Wake-Up feature.

```
//#define SIMULTANEOUS_EMISSION_RECEPTION
```

Only if Debug is also defined.

This function is used for forcing the cell to simultaneously send and receive any message it is ordered to transmit to check the hardware integrity of the CAN transceiver and controller.

2.1.5.5 Can_custom.c File

This is a source file you have to complete, to allow your application to react on hardware events as they happen. An example of implementation is given in Section 2.2.3 "Implementing the Notification Functions".

Functions called unconditionally

```
CAN_Buffer* CAN_Request_Buffer(u16 ident_of_message)
```

This function is called unconditionally when a new data message is available in the hardware buffer of the cell. This function has to be completed to return a pointer on a buffer structure. To ignore it, return NULL. To help you to manage your reception buffer(s), the ID of the message is passed as a parameter.

```
void CAN_Remote_Reception_Notification(u16 ident_of_remote)
```

This function is called unconditionally when a remote message has been saved in a hardware buffer. Its ID is passed as a parameter for a quick answer.

```
void CAN_Data_Reception_Notification(u16 message_ident)
```

This function is called unconditionally when a data message has been successfully saved in a software buffer supplied by the application. Its ID is passed as a parameter.

```
void CAN_Transmission_Notification(void)
```

This function is called unconditionally upon the successful transmission of a message.

Functions called conditionally

The following functions are called only if the corresponding option is set in can_custom.h.

```
void CAN_Dominant_Bit_Reception_Notification(void)
```

This function is called upon reception of a dominant bit while in Standby mode, if the RUN_ON_STARTUP option was not defined in can_custom.h. The corresponding interrupt will be accepted only once. Then its acceptance flag will be cleared.

```
void CAN_Bus_Passive_Notification(void)
```

```
void CAN_Bus_Active_Notification(void)
```

```
void CAN_Bus_Off_Notification(void)
```

These functions are called after a status change.

Option: #define STATUS_CHANGE_NOTIFICATION

```
void CAN_General_Reception_Error_Notification(void)
```

This function notifies the application of any hardware reception errors.

Option: #define DEBUG and #define GENERAL_RECEPTION_ERROR

```
void CAN_Reception_Status(CAN_Receive_Error status)
```

This function is called after a reception attempt and returns the status of the software processing (See “Enum -type variables” on page 20).

Option: #define DEBUG

```
void CAN_Overrun_Notification(void)
```

This function notifies the application of any overruns.

Option: #define DEBUG

```
void CAN_Transmission_Error_Notification(CAN_Transmit_Error status)
```

This function notifies the application of any hardware transmission errors.

Option: #define DEBUG

2.2 HOW TO USE THE CAN DRIVER: A DEMO APPLICATION

In this section, we will describe step-by-step the configuration and programming of a simple test application using the ST7 CAN driver.

2.2.1 Application

First of all, we must define how the application will look, i.e. which messages our cell will be able to send, which ones it will accept to receive, and how it will behave when specific messages are received.

Let's imagine the following:

- The cell has to run immediately after power-on, and does not have to send a dominant pulse.
- Every 15 ms the cell must send the contents of the ST7 A/D Converter data register. The identifier (ID) of this message could be, for example, 0x402.
- Upon reception of a remote frame (see Section 1.2 "CAN Frame") it must reply with the transmission of a given message. The ID of the remote frame could be, for example, 0x500 (consequently, the ID of the answer will also be 0x500).
- Upon reception of a given data item, the CAN cell must shut down. This ID of the message could be 0x600, and the data item 0xFF, in its first data byte.
- The cell is supposed to receive 3 other data messages coming from other nodes. Let's imagine they are identified by 0x127, 0x311, 0x3A5.

– Identifiers may exist on the bus that do not concern our cell.

2.2.2 Cell Configuration

Open then the can_custom.h file. You can see the two first lines of code:

```
//#define WAKE_UP_PULSE  
//#define RUN_ON_STARTUP
```

According to our requirements (See Section 2.2.1 "Application"), we only want to define the RUN_ON_STARTUP option.

So modify the code the following way:

```
//#define WAKE_UP_PULSE  
#define RUN_ON_STARTUP
```

2.2.2.1 Bit Timing

First of all, we have to decide the speed of our network. Let's say, for example, 250 kilobaud.

Look in your can_custom.h file. You see the following code:

```
#define INIT_BRPR 0x00  
#define INIT_BTR 0x00
```

The following two registers define the bit timing in the cell.

The BRPR register contains the size of time quantum, in number of clock ticks, in a bit field named BRP (See Section 1.3.2 "Bit timing"). This field ranges from 0 to 63. The true value for a time quanta is then BRPR+1.

The BTR register contains the size of the two synchronization segments in time quanta, in two different bit fields: BS1 and BS2("). BS1 ranges from 0 to 7 and BS2 from 0 to 3. The actual length of bit segments in time quanta is then BS1+1 and BS2+1.

You must always chose BS1>BS2, so that the sampling point takes place in the second half of the bit.

Use the following formula:

$$f_{bus}(Bauds) = \frac{f_{cpu}(Hz)}{(1 + BRP) \times (3 + BS1 + BS2)}$$

For example, in our case, fcpu = 8 MHz.

So, fbus = fcpu/32.

We have then the following possibilities:

BTR+1	BS1+BS2+3
2	16

BTR+1	BS1+BS2+3
4	8
8	4

Let's choose, for example, BTR = 3, BS1 = 3, BS2 = 2 (second row).

We have to complete the code:

```
#define INIT_BRPR 0x03
#define INIT_BTR 0x23
```

2.2.2.2 Filtering

The driver is able to filter out all messages not needed by the application. First by using hardware filters, and second by using software filters.

Use the hardware filters to eliminate as many identifiers as possible and to avoid further processing. Use the software filters to eliminate IDs that are unwanted, but that can not be stopped by the hardware.

Hardware Filter Configuration

Let's define the values of hardware masks and filters. To do this, we must split the IDs into two groups:

- 0x127, 0x311 and 0x3A5, on one hand; and,
- 0x500 and 0x600 on the other.

Note: When grouping the IDs, try to maximize the number of identical bits inside the same group, thus minimizing the width of the ID ranges accepted by the cell.

Then let's find the first filter/mask pair (12 bits to be determined):

- 0x500 is written in binary: 101 0000 0000
- 0x600 is written in binary: 110 0000 0000

In the first three bits, only the most significant bit (MSB) of both identifiers is the same, the following two being different. So, the three MSBs of the mask will be 1 0 0 (match, don't care, don't care) and the three MSBs of the filter will be 1 and then either 1 or 0.

The following eight bits are identically null. So the last eight bits of the filter will be 0, and the last eight bits of the mask will be 1 (match required).

The least significant bit (LSB) of the filter/mask is used to separate remote frames and data frames. Here we have a data frame and a remote frame, so it does not have to be checked (1 or 0 into the filter, 0 into the mask).

So we have:

- Filter 1000 0000 0000
- Mask 1001 1111 1110

Now look at the `can_custom.h` file:

There are several `#define` statements, including:

```
#define INIT_FHRi 0x00
#define INIT_FLRi 0x00
```

where `i` is either 0 or 1.

These are the two registers containing hardware filters. In the `FHRi` register, the 8 MSBs for the filters are given, and in the second register the 4 LSBs are given followed by 4 zeros.

We have to do the same thing for the mask. First, let's write 0 for the filter.

Finally we have:

```
#define INIT_FHR0 0x80
#define INIT_FLR0 0x00
#define INIT_MHR0 0x9F
#define INIT_MLR0 0xE0
```

Doing the same thing with the other group of identifiers leads to:

```
#define INIT_FHR1 0x20
#define INIT_FLR1 0x20
#define INIT_MHR1 0xA9
#define INIT_MLR1 0x30
```

Software Filter Configuration

You need to use software filtering feature if the hardware cannot stop all the undesired identifiers. Look at the following code in `can_custom.h`:

```
//SOFTWARE ACCEPTANCE MASKS
//#define FILTERS_ENABLED
//#define INIT_FILTERS { }
```

To allow software filtering, remove the `“//”` comment signs, and enter the identifiers between the parentheses. Please note that the filters must be given in **hexadecimal format** with **four digits**, always **terminated by zero**, and in **increasing order**.

That is to say in our case:

```
SOFTWARE ACCEPTANCE MASKS: optional choice
#define FILTERS_ENABLED
#define INIT_FILTERS {0x1270,0x3110,0x3a50,0x5000,0x6000}
```

Note: There can not be more than 127 identifiers in the array.

2.2.3 Implementing the Notification Functions

The cell is now configured, we no longer need to worry about hardware.

We have then to write our code. Look at the last lines of can_custom.h. There is a set of **#define** options. As we want to be notified neither of status changes, nor of errors, we will leave them as comments. Please see Section 2.1.5.5 "Can_custom.c File" for more details about notification functions.

We must then open can_custom.c, and learn how to use the notification functions that are always compiled.

If your application uses the watchdog timer, you have to write on top of the file:

```
#include "wdg.h"
```

to be able to use the refresh function in this module.

The CAN_Request_Buffer function

To retrieve data stored in the ST7 buffers after reception, the application must pass a software buffer when requested. The following prototype is given in the code:

```
CAN_Buffer* CAN_Request_Buffer(u16 ident_of_message)
{
//The application must here return a pointer to a physical structure CAN_Buffer
}
```

This routine is called each time a message has been successfully filtered and is ready to be used. The parameter passed (i.e. the ID of the recovered message) may help you manage your buffer(s) more easily.

You then have to create a buffer that will be used to save all data messages.

At the top of the file, add:

```
////////////////////////////////////
//VARIABLES////////////////////////////////////
////////////////////////////////////
CAN_Buffer reception_buffer;
```

And then in the function body:

```
CAN_Buffer* CAN_Request_Buffer(u16 ident_of_message)
{
reception_buffer.buffer_rw=CTRUE;
return &reception_buffer;
}
```

The two first lines are used as a safety device: the driver will then be sure that the buffer is not currently in use and the data in that buffer can be overwritten. In your programs, use these fields as keys to know whether the data in a buffer can be accessed and whether it has already been processed.

Note 1: There is only ONE buffer here that will be used to save all the receive messages. This is only an

example! You can implement a buffer for each message type, a FIFO of standardized buffers etc.

Note 2: For safe programming, you should systematically verify whether the buffer is not currently being read/written, **and** whether the buffer is really free before further processing.

(For specific information concerning the buffer data type, see Section 2.1.5.1 "Data-type Variables").

Remember that one of the received messages may switch off the cell. Once a message is received, we have to check to see if it is this one. This is done using the `CAN_Data_Reception_Notification` function.

CAN_Data_Reception_Notification Function

The `CAN_Data_Reception_Notification` function is the following prototype in `can_custom.c`. The routine is called once the data in a data frame has been saved in the buffer passed in the `CAN_Request_Buffer` function. Before calling the `CAN_Switch_on` function, refresh the watchdog (See "Functions" on page 21, `CAN_Switch_Off` for further explanation). Let's add the following code:

```
void CAN_Data_Reception_Notification(u16 message_ident)
{
    if (message_ident==0x6000)//checks the id of message
    {
        if (reception_buffer.CAN_msg_data[0]==0xFF)//Checks the content of data
        {
            CAN_Switch_Off(BUS_WAKEUP);
        }
    }
}
```

So, if the first data byte of the message whose identifier is 0x600 contains 0xFF, the cell will switch off and wait for a bus Wake-Up command (a dominant bit).

CAN_Remote_Reception_Notification Function

When a remote frame is received, we must send a message with a 0x500 ID. Let's do it inside this routine which is called each time a remote frame is received.

The message does not exist yet. As for the buffer, we have to create a variable *message*, by adding the following code in the file:

```
////////////////////////////////////
//VARIABLES////////////////////////////////////
////////////////////////////////////

CAN_Buffer message_to_send_on_request= /
{0x5000,DLC5,{0x00,0x01,0x02,0x03,0x04},CFALSE,CFALSE};
```

The structure is initialized here with 0x500 ID, which has a length of five and five data items.

Note: In a real network, the message would not be statically initialized, but would be filled with the content of one or several variables. The aim here is only to show the way the function can be used.

Then we fill the function with a transmission request:

```
void CAN_Remote_Reception_Notification(u16 ident_of_remote)
{
    if (ident_of_remote==0x5000)
    {
        CAN_Transmit_Request(&message_to_send_on_request);
    }
}
```

CAN_Transmission_Notification Function

This function is called after each successful transmission. It is not required for our application, so let's leave it blank.

CAN_Dominant_Bit_Reception_Notification Function

This function is called each time a dominant bit is received while in Standby mode. Here, we want to be able to wake up the cell when this happens. So we add the following code:

```
void CAN_Dominant_Bit_Reception_Notification(void)
{
    CAN_Switch_On(&first_init_data,CFALSE);
}
```

The cell will be woken-up with the same configuration as when first initialized and a dominant pulse will not be sent at wake-up.

Note: For the exact meaning of the data parameters, see Section 2.1.5.2 "Functions"

All other notification functions can be used in the same way. They are compiled only if the corresponding options are chosen in `can_custom.h`.

2.2.4 Transmissions outside the CAN Interrupt Function

As part of the user interface, the `CAN_Transmit_Request` routine can be used outside the interrupt function of the CAN driver. Below is an example of a message transmission on a timer event. The content of the A/D converter of the ST7 microcontroller will be sent every 15 ms.

First of all, we must configure the timer by modifying the existing code.

At the top of the `tima.c` file, add:

```
#include "can.h"
#include "lib.h"
#include "adc.h"
```

Then declare a `CAN_Message` -type variable:

ST7 pCAN PERIPHERAL DRIVER

CAN_Buffer periodic_transmission;

In the TIMA_Init() function, make sure the following lines are included:

```
TACR1=0x40
```

```
TACR2=0x08
```

```
TAOC1HR=0x3A
```

```
TAOC1LR=0x98
```

and finally,

```
#asm
```

```
LD _TAOC2HR,A; /* Write the Output Compare 2 high register to disable the OC2 */
```

```
LD A,_TASR /* Clear the flags in case it is already set. To Clear */
```

```
LD A,_TAOC1LR /* OC1F flag: Read Status Register and Access OC1R low byte, clearing OC1F flag */
```

```
LD A,_TAOC2LR /* OC2F flag: Read Status Register and Access OC2R low byte, clearing OC2F flag*/
```

```
LD _TAOC2HR,A//No access to low byte: OutputCompare 2 ITs disabled
```

```
#endasm
```

Note: The explanation of the code written here concerns timer programming and is beyond the scope of this document. Its purpose is to configure timer A to trigger a timer interrupt every 15 ms. Further explanations of timer functions can be found in the microcontroller datasheet.

Then we have to fill in the IT function of the timer:

```
void TIMA_Interrupt(void)
```

```
{
```

```
  u16 output_value;
```

```
  if (ValBit(TASR,OCF1))
```

```
    {
```

```
      TASR;
```

```
      output_value = ((unsigned int)TAOC1HR << 8) | TAOC1LR;
```

```
    }
```

```
  output_value += 0x3A98;
```

```
  TAOC1HR = output_value >>8;
```

```
  TAOC1LR = (unsigned char) output_value;
```

```
//Note: The code above is only meant to update the value for the next IT
```

```
//Now comes the code that interests us
```

```
if (!periodic_transmission.message_in_queue) //Checks if the message is already  
//in the transmission queue
```

```
{
```

```
  periodic_transmission.msg_identifier=0x4020;
```

```
  periodic_transmission.data_size=DLC1;
```

```
  periodic_transmission.CAN_Msg_data[0]=ADC_Get(0x00);
```

```

        CAN_Transmit_Request(&periodic_transmission);
    }
//We have given a transmission order here, that will be called on every
//timer IT if the message is not already in the transmission queue.
//The data is filled each time with the value of the A/D converter data
//register. For info. about the ADC, please see the datasheet.
}

```

IMPORTANT: Please note that WHEN USED OUTSIDE AN INTERRUPT ROUTINE, AND ONLY THEN, the transmission request MUST NOT BE INTERRUPTED. So, disable all ITs before a function call (SIM) and re-enable them afterwards (RIM) in the last step of the main.c file.

In the adc.c file, enter also the following code:

In the ADC_Init routine:

```
ADCCSR=0x20; //Starts the ADC peripheral
```

and write a function:

```

u8 ADC_Get(u8 channel)
{
ADCCSR |= channel;
return ADCDR;
}

```

Our application is almost entirely written now. Our last step is to fill the main.c file, to allow the entire program to run.

At the beginning of the file add:

```

#include "lib.h"
#include "adc.h"
#include "tima.h"
#include "can.h"
#include "can_custom.h"

```

Then complete the main function as follows:

```

void main(void)
{
    _asm("SIM"); //Disable interrupts

    /*          ----- */
    /*----- I N I T I A L I S A T I O N -----*/
    /*          ----- */

```

ST7 pCAN PERIPHERAL DRIVER

```
ADC_Init(); //Initializes the ADC
if ((CAN_First_Init())==CAN_INIT_FAILURE) //Initializes the CAN peripheral
{
    return;
}

TIMA_Init();//Initializes the timer

_asm("RIM");// EnableInterrupts;

/* ----- */
/*----- LOOP -----*/
while (1) /* ----- */
{

}

}
```

Finished! Now compile the entire code and run the software. Once the *while {1}* loop is entered, the microcontroller will run non-stop until it is shut down, reacting to every event, saving data in our buffer, sending data periodically and answering remote requests.

If you own a CAN bus simulation tool, you can monitor messages being received and sent by the ST7.

The next section of this application note will explain in detail the driver architecture and all software functions (including internal functions).

2.2.5 IMPORTANT: Reentrant Functions

If the memory model you chose for compiling your application does not use the physical stack but simulates it in RAM, you CANNOT allow functions to be reentrant.

The COSMIC compiler will generate an error if it finds some code that could be reentrant. For example, this may occur if you use a subroutine inside both an initialization function and an interrupt routine.

This is, of course, not a real error, but the compiler does not know this and prevents you from going further.

To fix this problem with the COSMIC compiler, use the following trick:

- Change the name of the function in your code, in the call that makes the error appear.

- For example, rename `function` to `function_init_call`.
- In the link file (extension `.lcf`), define an alias the following way:

```
+def _function=_function_init_call //!!
```

Note the underscore as first character.
- If the function takes parameters, add also:

```
+def _function$L=_function_init_call$L//!!
```

This is the way the parameters names are generated by the compiler
- Save the file and compile.

IN ANY CASE, ALWAYS MAKE SURE THAT YOUR CODE IS NOT ACTUALLY REEN-
TRANT, IF IT IS, IT WON'T RUN THE WAY YOU EXPECT, EVEN IF YOU HAVE COMPILED
IT SUCESSFULLY!

3 DETAILED DESCRIPTION

In the following section we will give a detailed description of function algorithms. We will also look at the internal aspects of the driver.

3.1 USER INTERFACE FUNCTIONS

As described above in the routine parameters and return values, the algorithm will only be shown on flowcharts. For more information, refer to Section 2.1.5.2 "Functions".

void CAN_It_Dis(void):

Simply clears the CAN Interrupt control register.

u8 CAN_Get_TEC(void):

Simply returns the value of TEC.

u8 CAN_Get_REC(void):

Simply returns the value of REC.

CAN_Init_Error CAN_First_Init(void)

Figure 13. CAN_First_Init Flowchart

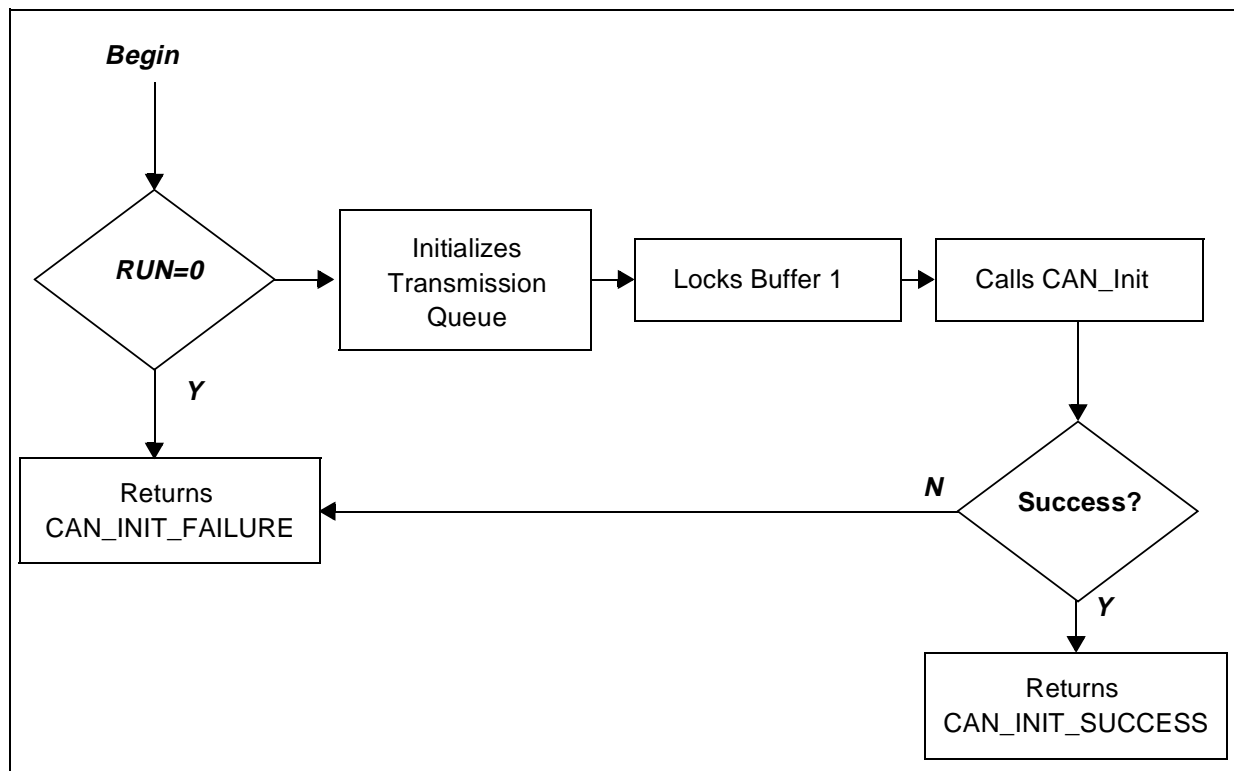

CAN_Status CAN_Get_Status (void)

Figure 14. CAN_Get_Status Flowchart

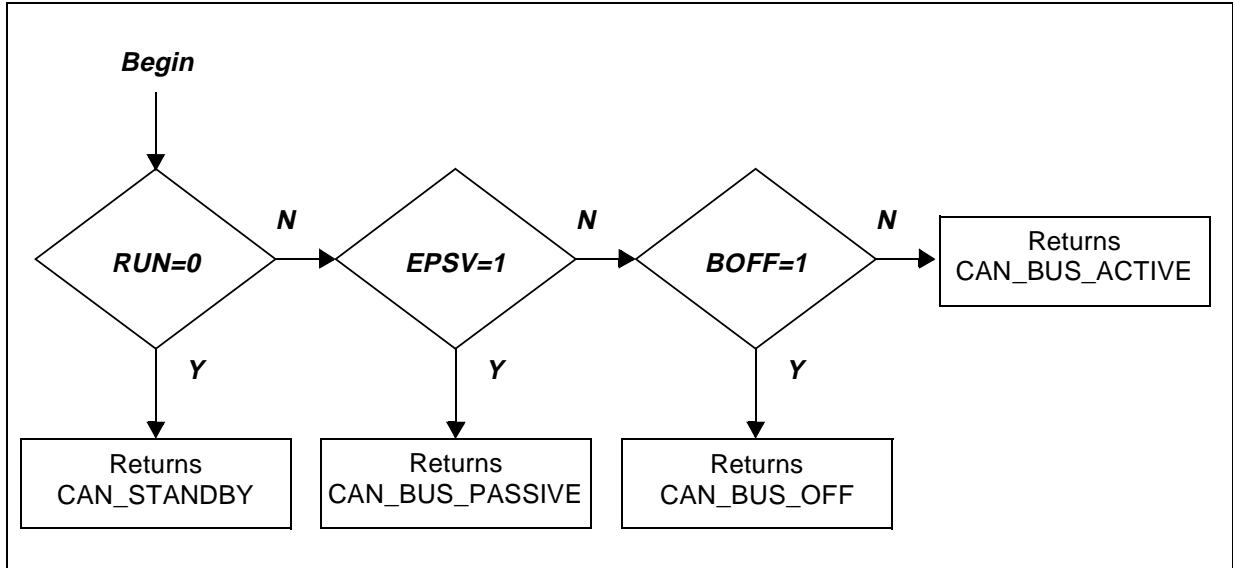

CAN_Switch_Error CAN_Switch_Off(WakeUp_Cause)

Figure 15. CAN_Switch_Off Flowchart

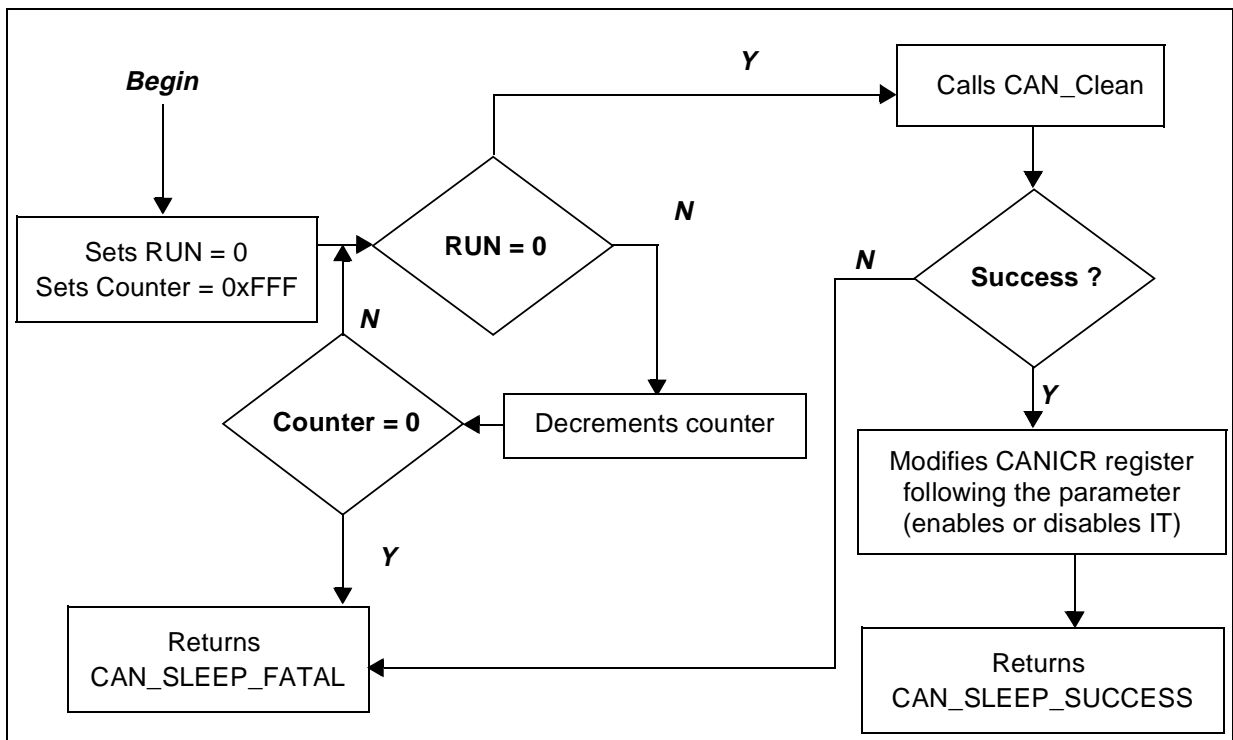

CAN_Switch_Error CAN_Sleep (WakeUp_Cause)

Figure 16. CAN_Sleep Flowchart

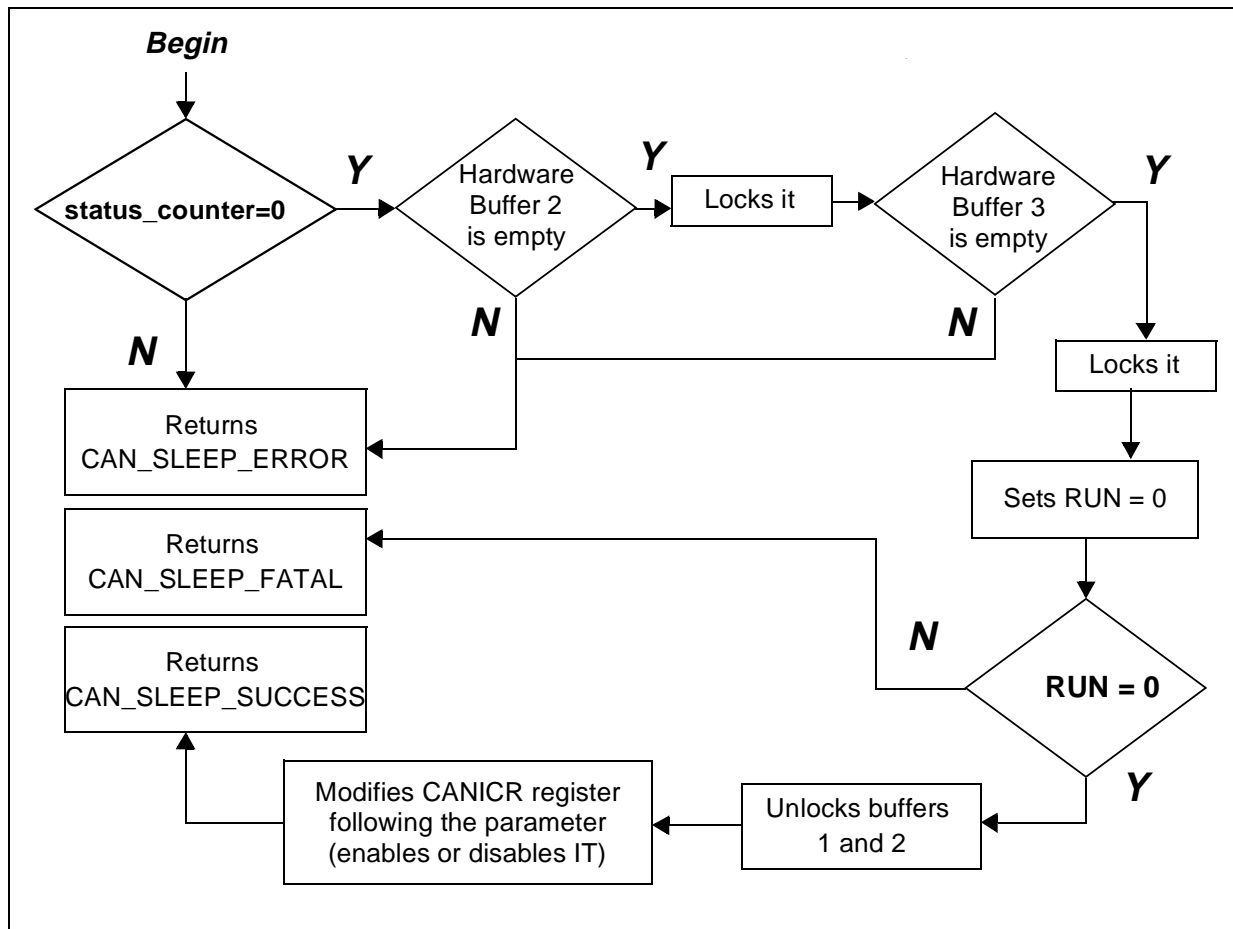

CAN_Switch_Error CAN_Switch_On(Init_Data_Ptr,CAN_Bool)

Figure 17. CAN_Switch_On Flowchart

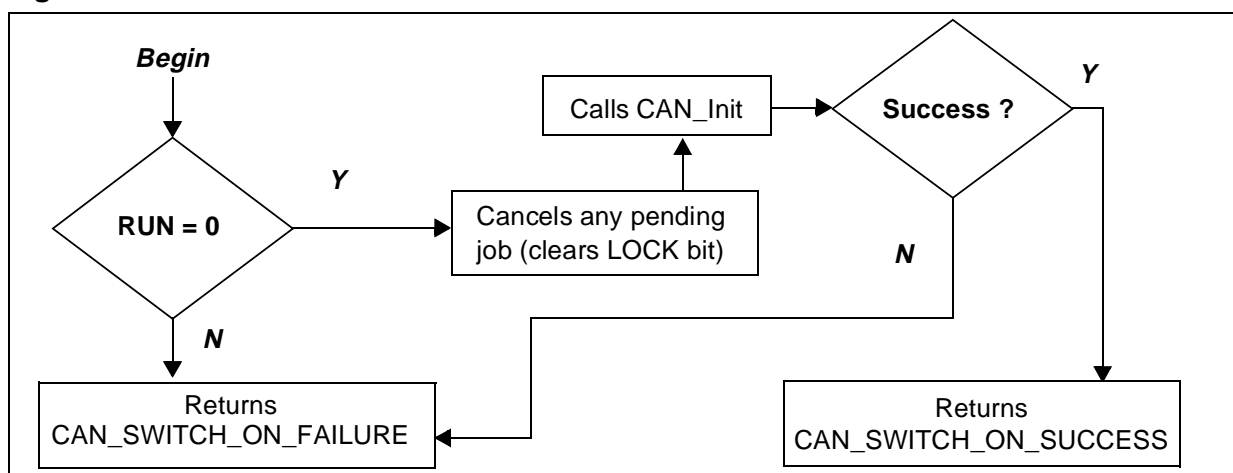

CAN_Transmit_Error CAN_Transmit_Request(CAN_Message*)

Figure 18. CAN_Transmit_Request Flowchart

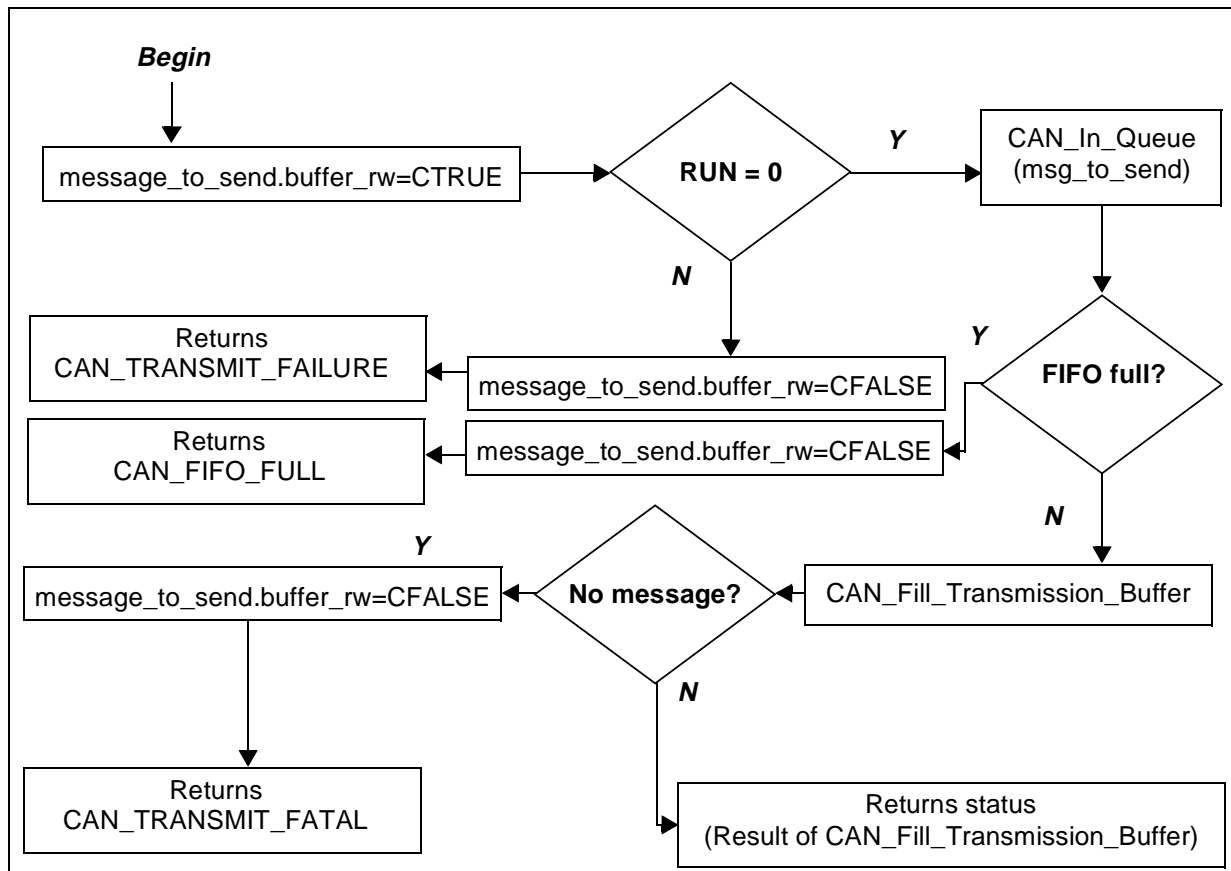

3.2 INTERNAL FUNCTIONS AND DATA TYPES

3.2.1 Internal Data Types and Variables

3.2.1.1 Transmission FIFO

To avoid losing data, messages to be sent are queued in a 3-message length FIFO prior to transmission.

Queue Unit

In fact, no physical CAN_Message structure is put into the queue. The objects handled are described below:

```

typedef struct FIFO_Object
{
  CAN_Message* message;
  struct FIFO_Object* next_object;
  struct FIFO_Object* preceding_object;
}FIFO_Object;
  
```

Only a pointer to the message appears in the structure, to avoid complex data manipulations. The two following fields are pointers to other FIFO_Object structures.

FIFO Management Structure

In the main structure, we find:

```
typedef struct {
u8 fifo_size;
FIFO_Object* first_object;
FIFO_Object* last_object;
CAN_Bool isinuse;
} FIFO;
```

The structures shown here look more like parts of a chained-list. Indeed, the data-type implemented is not pure FIFO, but simulates the behaviour of a real queue.

Three *FIFO_Objects* are statically defined and linked together in a circular way (in the *CAN_First_Init* routine). One FIFO variable is also defined and initialized in the meantime (cf. in *can.c*):

```
//Transmission queue
static FIFO CAN_transmit_queue;
static FIFO_Object CAN_queue_object_1;
static FIFO_Object CAN_queue_object_2;
static FIFO_Object CAN_queue_object_3;
```

The maximum size of the queue is therefore 3.

To simulate in-queuing/out-queuing, you only have to verify that the size limit will not be overridden, and update the fields in the FIFO structure.

The “isinuse” Boolean is checked each time the variable is accessed to prevent read/write conflicts.

Figure 19. FIFO Transmission System

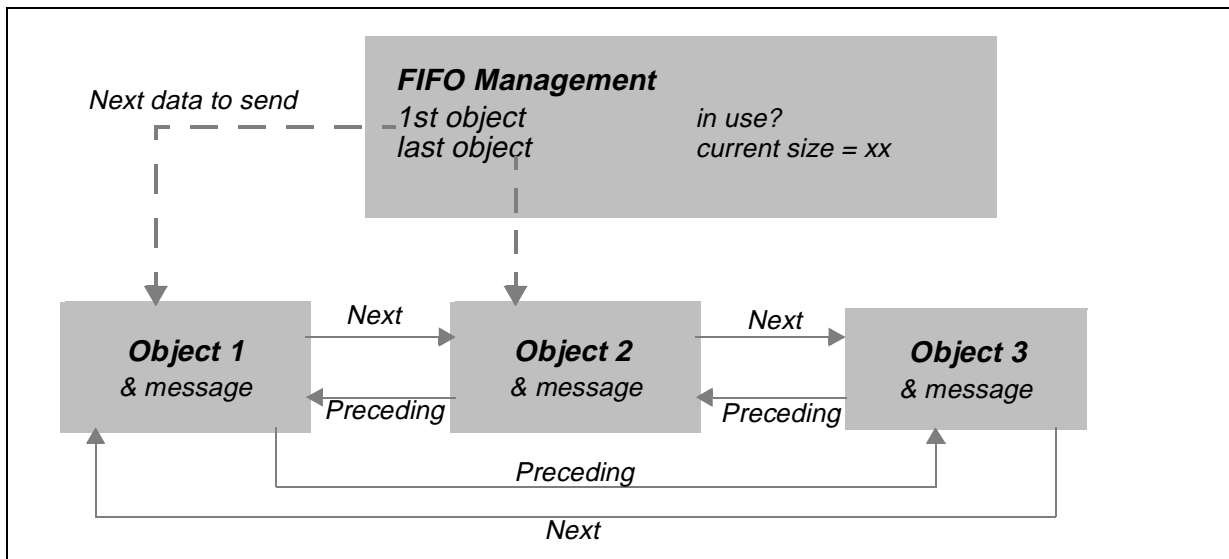

For more information, refer to Section 3.2.2 "Internal Routines", (CAN_In_Queue and CAN_Out_Queue).

3.2.1.2 Software Filters

Once the *SOFTWARE_FILTERS* option is defined in *can_custom.h* and the list of filters is completed, the compiler will define and initialize a structure containing the data.

```
typedef struct{
u8 array_size;
u16* filters_array;
}CAN_Filters_Array;
```

This structure is composed of the size of the array, automatically calculated at compilation, and of an array of 2-byte long numbers.

Consequently, the following constants are defined in the *can.c* file:

```
const u16 i_filters[]=INIT_FILTERS;
const CAN_Filters_Array CAN_filters={
    Size_Of_Words_Array(i_filters),
    i_filters
};
```

As we can see, they are immediately initialized. *Size_Of_Words_Array* is a macro and *i_filters* is the array filled with your data.

You can access the *i_filters* array, declared as *extern const* in *can.h*.

3.2.1.3 Enum Types

They are used as return values for some internal routines.

ST7 pCAN PERIPHERAL DRIVER

```
typedef enum {CAN_FILTER_MATCH, CAN_FILTER_NO_MATCH} CAN_Filter_Status;
```

Return values of the software filtering routine.

```
typedef enum {ITERR, ITRECEPT, ITTRANSMIT, ITSCIF} IT_Type;
```

Return values of the routine that determines which IT has to be processed first.

```
typedef enum  
{CAN_CLEAN_FATAL, CAN_CLEAN_SUCCESS, CAN_CLEAN_FAILURE} CAN_Clean_Error;
```

Return values of the Cleaning function.

3.2.1.4 Status Counter

```
static u8 status_counter=0;
```

This is a variable used by the Sleep function to determine the state of the reception and transmission registers. It is updated the following way:

- +1, when a reception IT is taken into account
- -1, when a reception buffer is released
- +1, when a message is put into the transmission queue
- -1, when a message is sent (in the IT function)

When the CAN_Sleep function is called, a simple test of this variable lets the driver know if there are still pending jobs and if the Sleep operation must be cancelled.

3.2.2 Internal Routines

3.2.2.1 Static CAN_Filter_Status CAN_Filter(u16 ident_code)

INPUT	CAN message identifier
OUTPUT	Error status
DESCRIPTION	Tests matching of IDs of received messages and software filters. Possible returned status: CAN_FILTER_MATCH and CAN_FILTER_NO_MATCH
COMMENTS	Called by CAN_Receive Compiled only if FILTERS_ENABLED is set. Priority is given here to SPEED, that's why the code may look strange.

Performs a classical dichotomy algorithm and compares the value given as parameter with the contents of the i_filters array.

3.2.2.2 static IT_Type CAN_Get_IT_Type(void)

INPUT	--
OUTPUT	Generic type of the event that caused the IT
DESCRIPTION	Tests matching of IDs of received messages and software filters. If the DEBUG option is defined, checks the IT Error flags first. Otherwise checks the Reception ITs first. Possible status returned: ITRECEPT for reception IT, ITTRANSMIT for transmission IT and ITERR for error IT.
COMMENTS	Called by CAN_Interrupt.

Figure 20. CAN_Get_IT_Type Flowchart

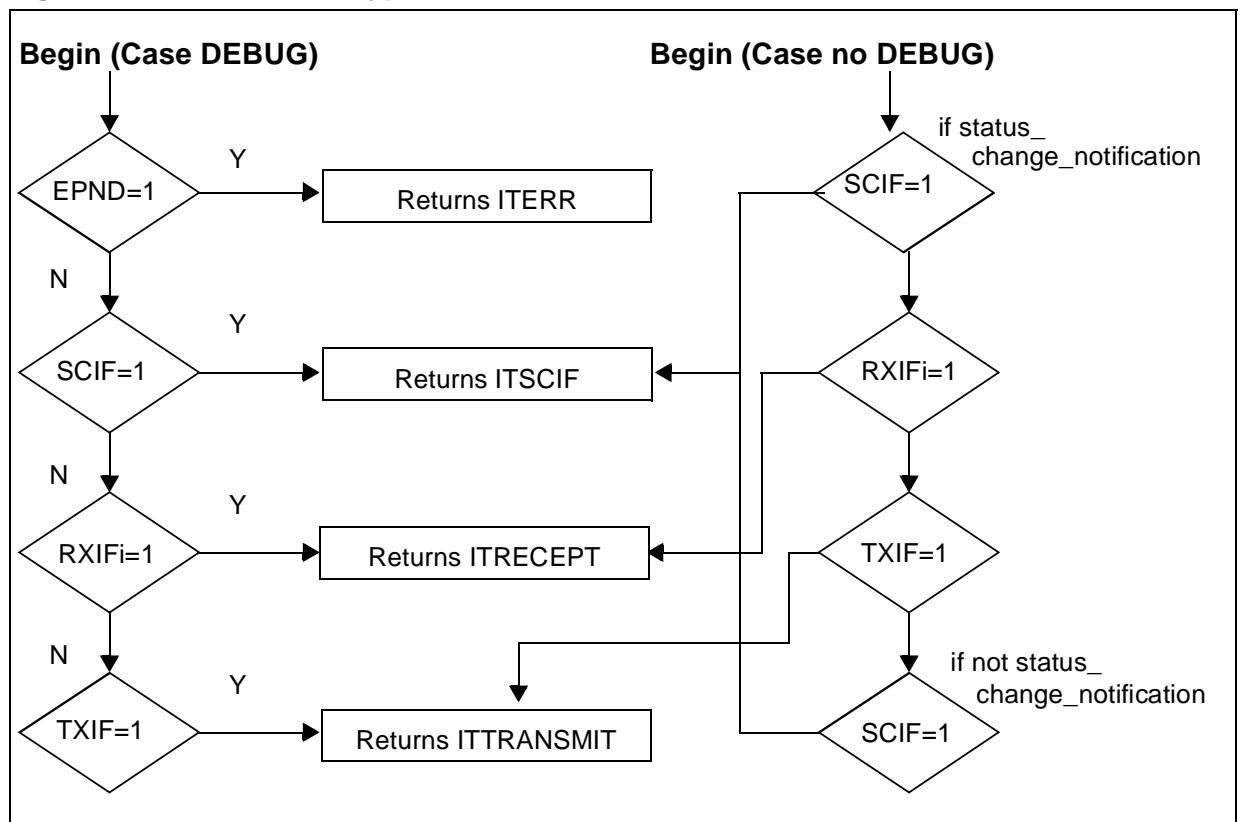

3.2.2.3 static CAN_Init_Error CAN_Init(Init_Data_Ptr data_ptr, CAN_Bool run_set, CAN_Bool wkup_set)

INPUT	Pointer to an Init_Data structure, Boolean, Boolean
OUTPUT	Error status
DESCRIPTION	CAN cell internal registers initialization. Not executed if RUN bit set. The first Boolean determines if the RUN bit has to be set or not. The second Boolean determines if the cell has to send a wake-up dominant bit. Possible status returned: CAN_INIT_FAILURE and CAN_INIT_SUCCESS
COMMENTS	Called by CAN_Switch_On, CAN_First_Init

Figure 21. CAN_Init Flowchart

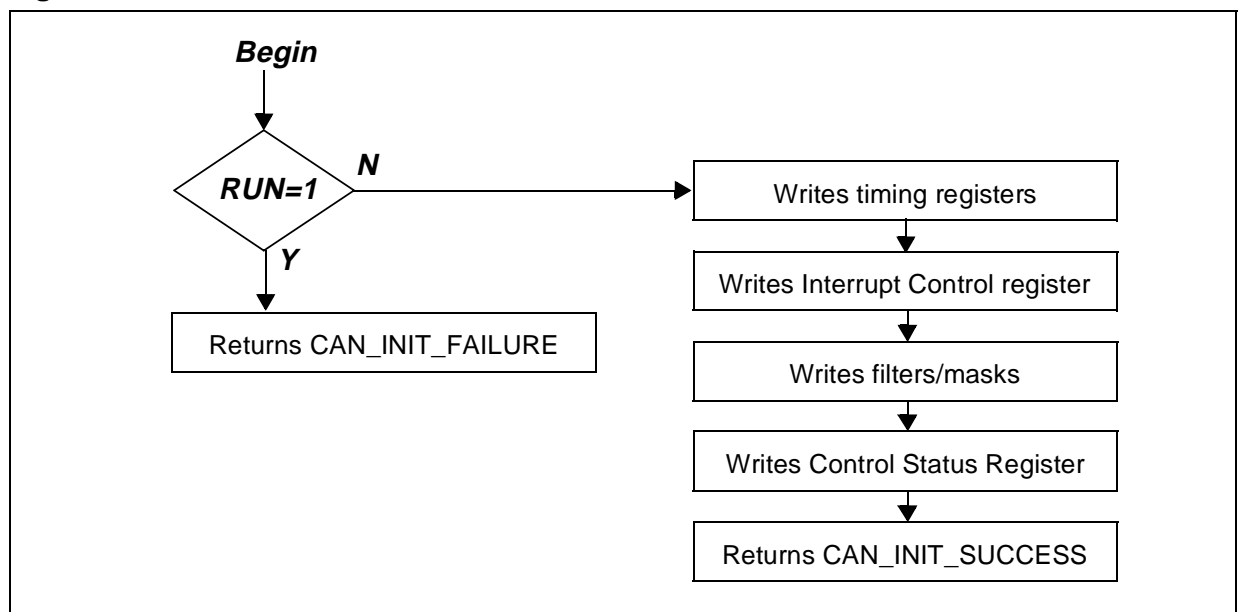

3.2.2.4 static CAN_Transmit_Error CAN_In_Queue (CAN_Message* msg_to_queue)

INPUT	Pointer on a CAN message
OUTPUT	Error code
DESCRIPTION	Tests matching of IDs of received messages and software filters. Possible return values: CAN_FIFO_FULL, CAN_TRANSMIT_SUCCESS and CAN_TRANSMIT_FATAL.
COMMENTS	Must not be interrupted Called by CAN_Transmit_Request

Figure 22. CAN_In_Queue Flowchart

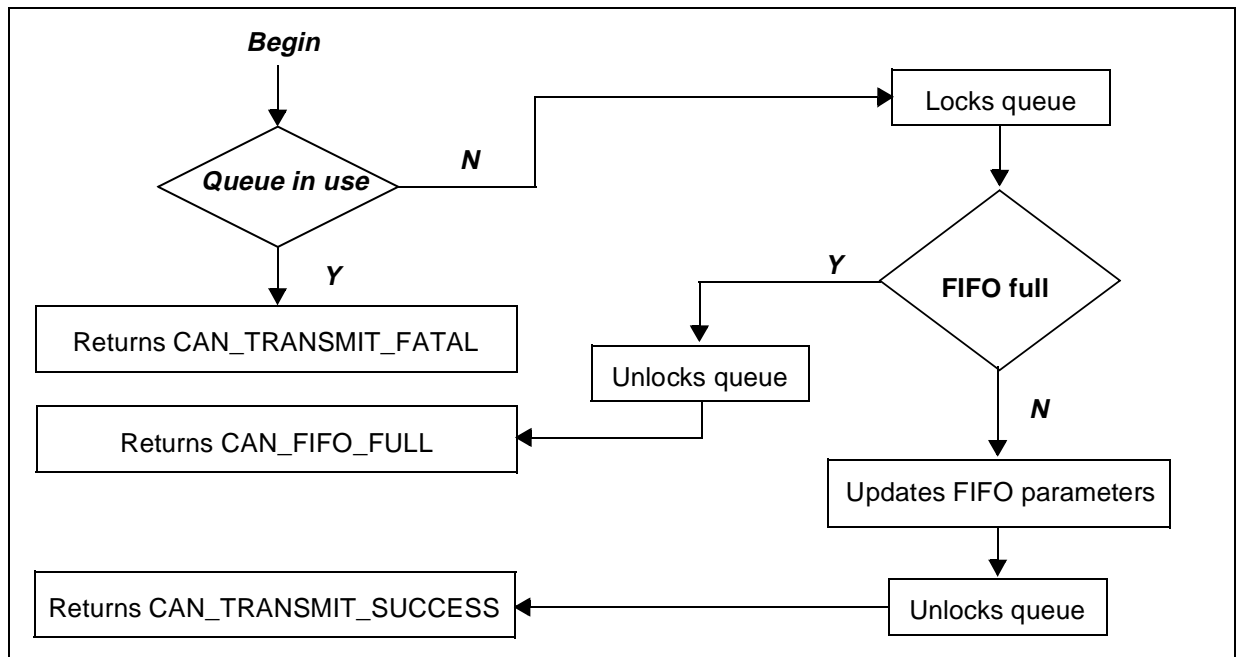

3.2.2.5 static CAN_Message* CAN_Out_Queue (void)

INPUT	--
OUTPUT	Pointer to a CAN message
DESCRIPTION	Returns a pointer to the first message in the transmission queue and updates the queue parameters
COMMENTS	Must not be interrupted Called by CAN_Fill_Transmission_Buffer

The algorithm is exactly the same as for CAN_In_Queue().

3.2.2.6 static CAN_Clean_Error CAN_Clean (void)

INPUT	--
OUTPUT	Error status
DESCRIPTION	Cleans the reception and transmission buffers, and resets the transmission queue in the first initialization state. Only affects pointers Possible return values: CAN_CLEAN_FAILURE, CAN_CLEAN_SUCCESS and CAN_CLEAN_FATAL
COMMENTS	Must be called only in Sleep mode (run bit reset) Must not be interrupted Called by CAN_Sleep and CAN_Switch_Off

Figure 23. CAN_Clean Flowchart

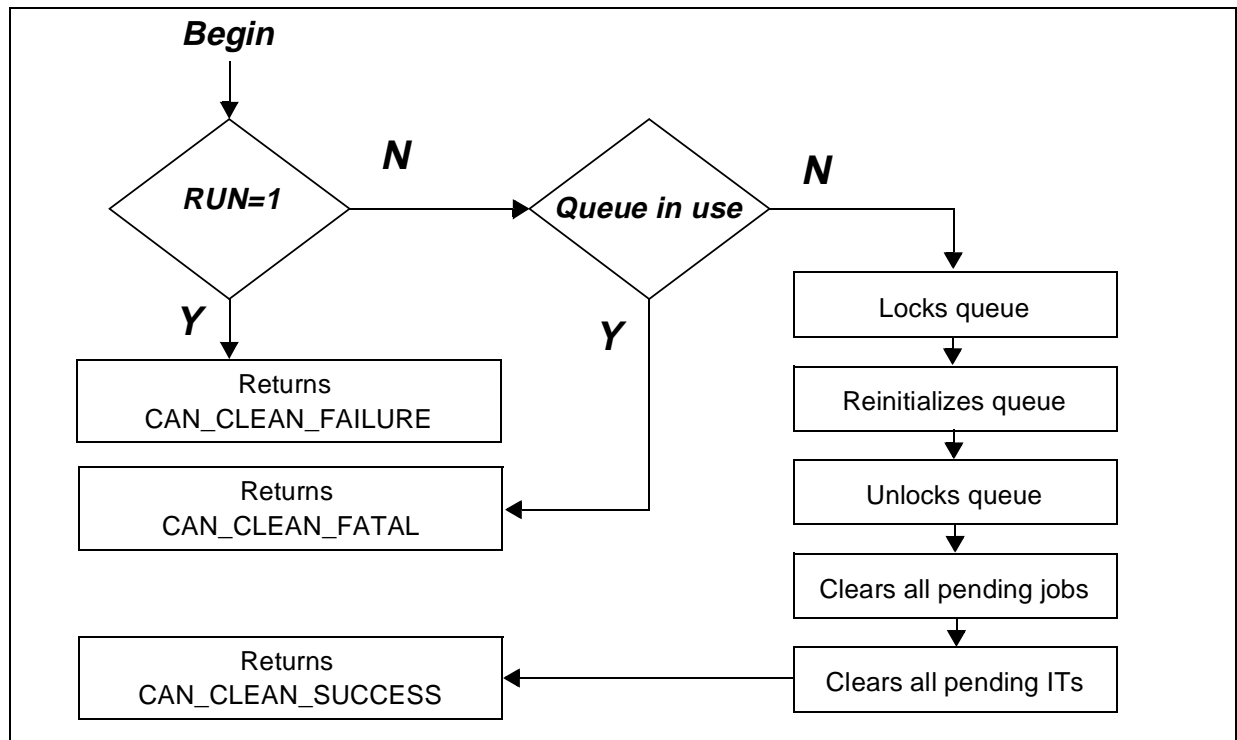

3.2.2.7 static CAN_Transmit_Error CAN_Fill_Transmission_Buffer()

INPUT	--
OUTPUT	Error status
DESCRIPTION	Fills the hardware buffer for transmission. Possible return values: CAN_TRANSMIT_BUFFER_FULL, CAN_TRANSMIT_NO_MSG and CAN_TRANSMIT_SUCCESS
COMMENTS	ITs have to be disabled Called by CAN_Transmit_Request Calls CAN_Out_Queue

Figure 24. CAN_Fill_Transmission_Buffer Flowchart

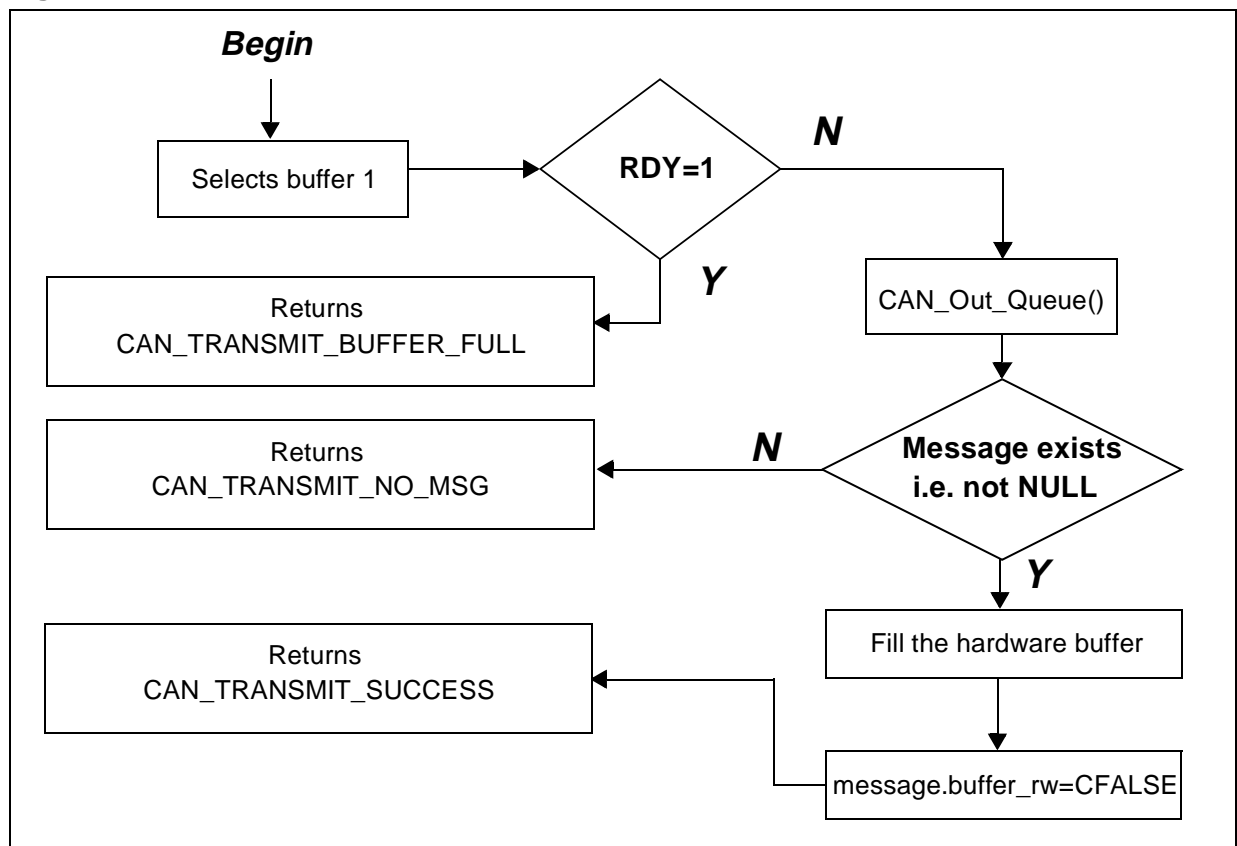

3.2.2.8 static CAN_Receive_Error CAN_Store_Rcvd_Msg(u8 num_buff_hard, CAN_Recept_Buffer* dest_ptr)

INPUT	Number of the hardware buffer to release, pointer to the buffer where the data must be saved
OUTPUT	Error status
DESCRIPTION	Fetches data received in a hardware buffer. Possible return values: CAN_ILLEGAL_IDENTIFIER and CAN_RECEIVE_SUCCESS
COMMENTS	ITs have to be disabled. This function is called by CAN_Reception, only in case of reception of data. The priority was given to SPEED here, that's why the code may look strange.

Figure 25. CAN_Store_Rcvd_Msg Flowchart

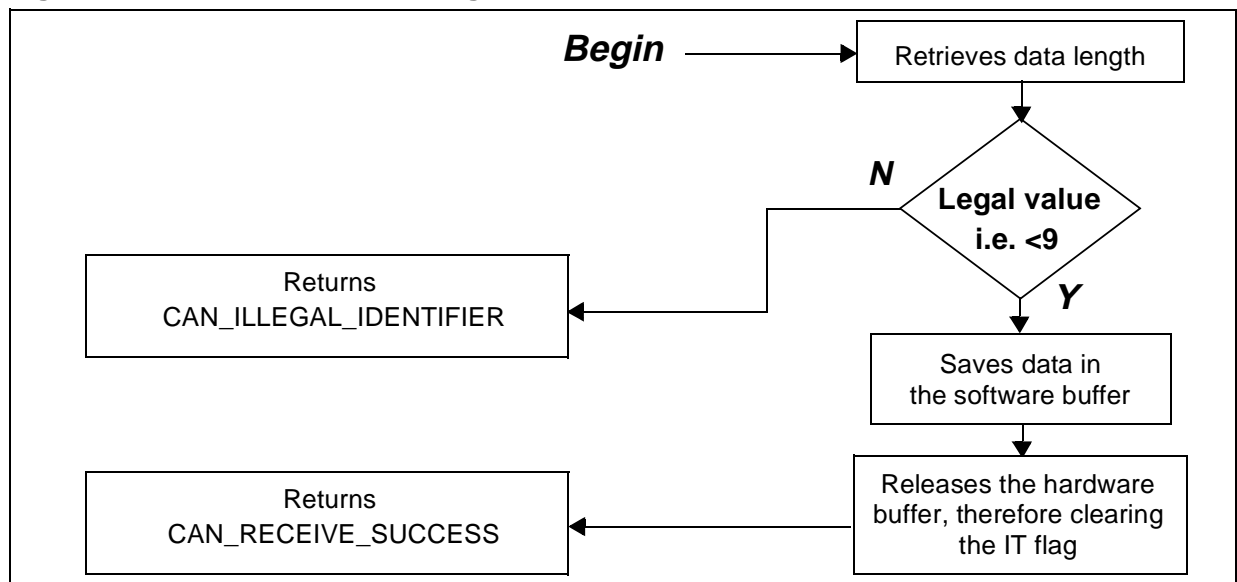

3.2.2.9 static CAN_Receive_Error CAN_Receive(u8 num_buff_hard)

INPUT	ID of the buffer to void, pointer on the software buffer to fill.
OUTPUT	Error status
DESCRIPTION	Fetches data received in a hardware buffer and saves them in a software buffer supplied by the application.
COMMENTS	ITs have to be disabled Calls CAN_Filter (if SOFTWARE_FILTER option is enabled) Calls CAN_Request_Buffer Possible return values: CAN_FILTERING_FAILURE, CAN_RECEIVE_REMOTE, CAN_NO_BUFFER, CAN_RECEIVE_FATAL and CAN_RECEIVE_SUCCESS

Figure 26. CAN Receive Flowchart

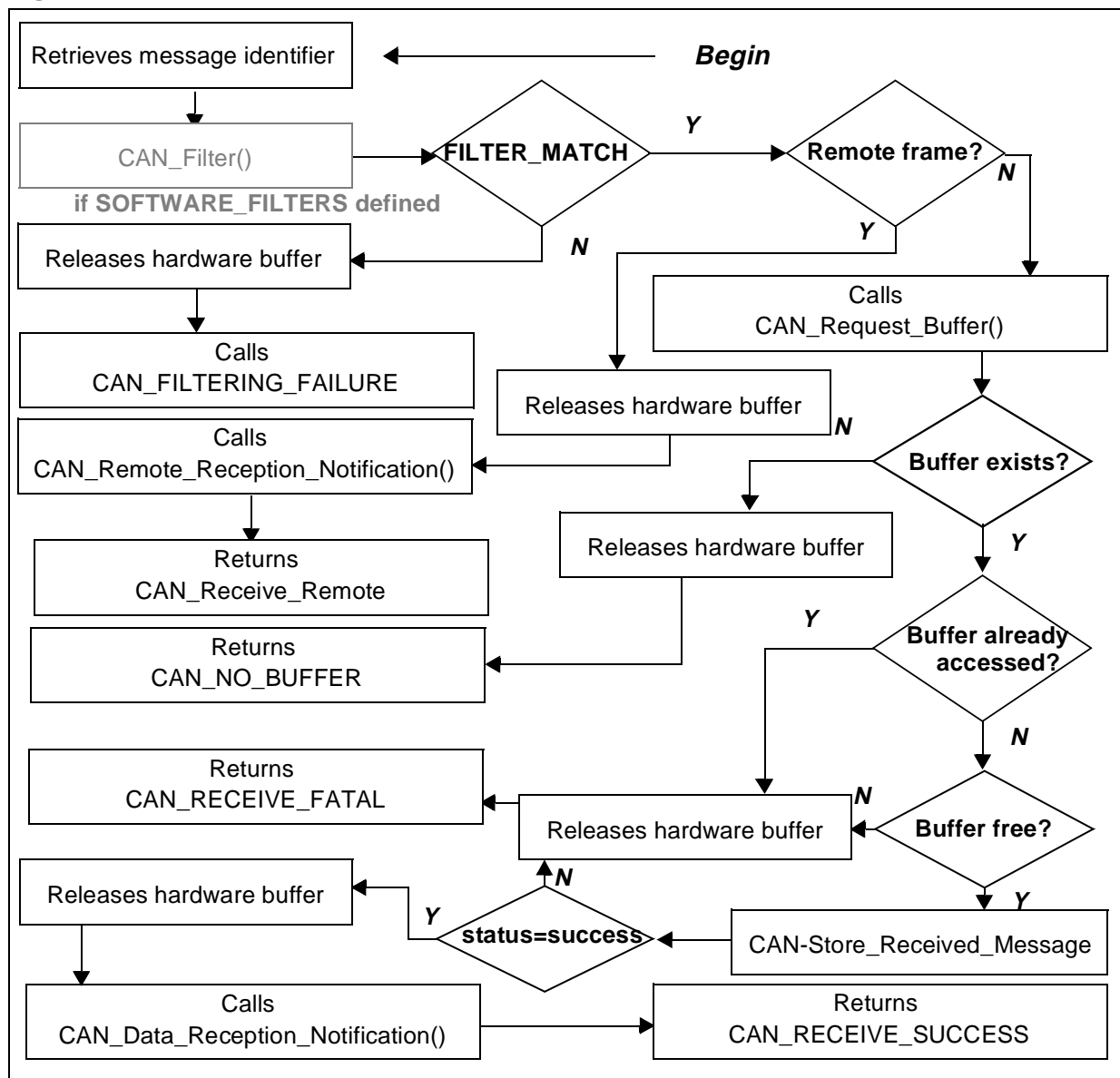

3.2.2.10 Interrupt Routine

INPUT	--
OUTPUT	--
DESCRIPTION	Interrupt processing function.
COMMENTS	Calls CAN_Get_IT_Type CAN_Reception_Notification CAN_Transmission_Notification CAN_Fill_Transmission_Buffer CAN_Dominant_Bit_Reception_Notification May call (optional, see Section 2.1.5.4 "Can_custom.h File"): CAN_Transmission_Error_Notification CAN_Bus_Passive_Notification CAN_Bus_Active_Notification CAN_Bus_Off_Notification CAN_Overrun_Notification CAN_General_Reception_Error_Notification

Figure 27. Interrupt Routine Flowchart

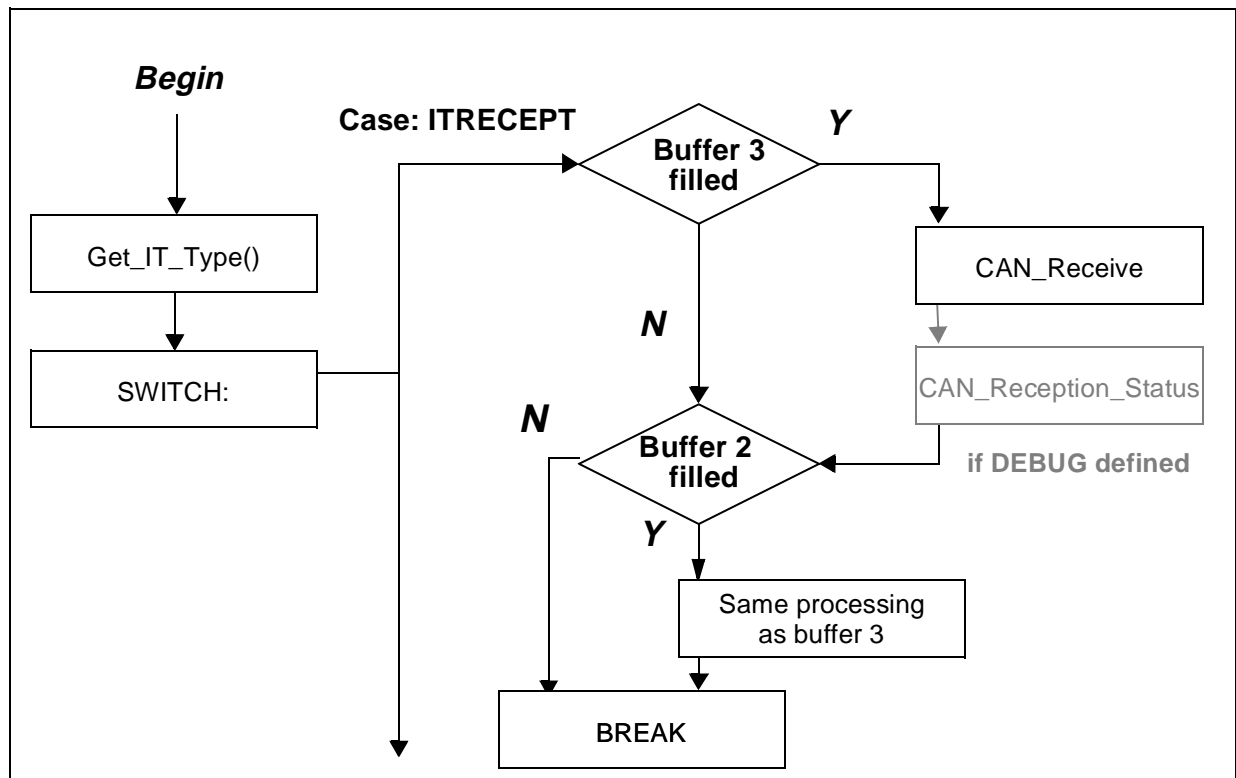

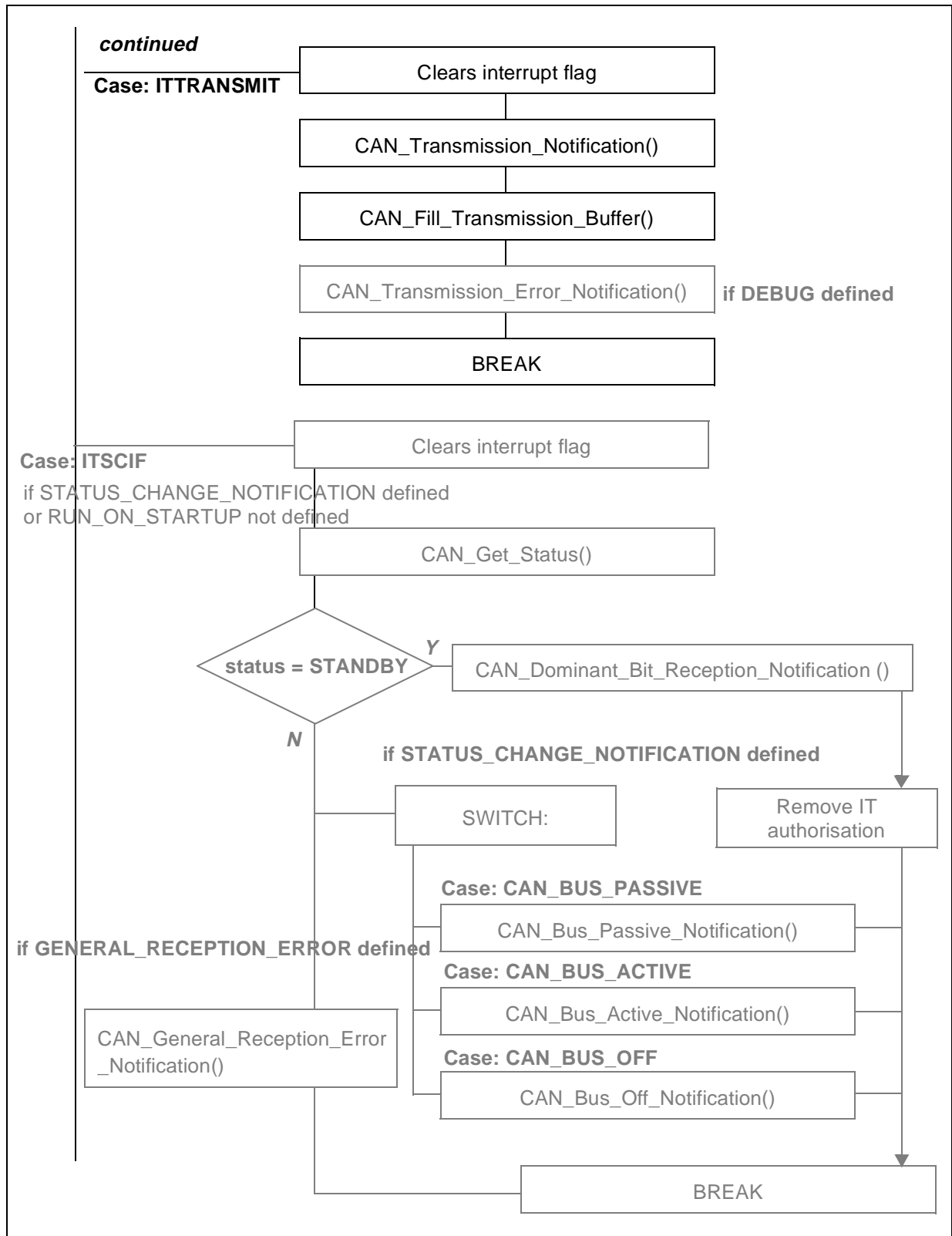

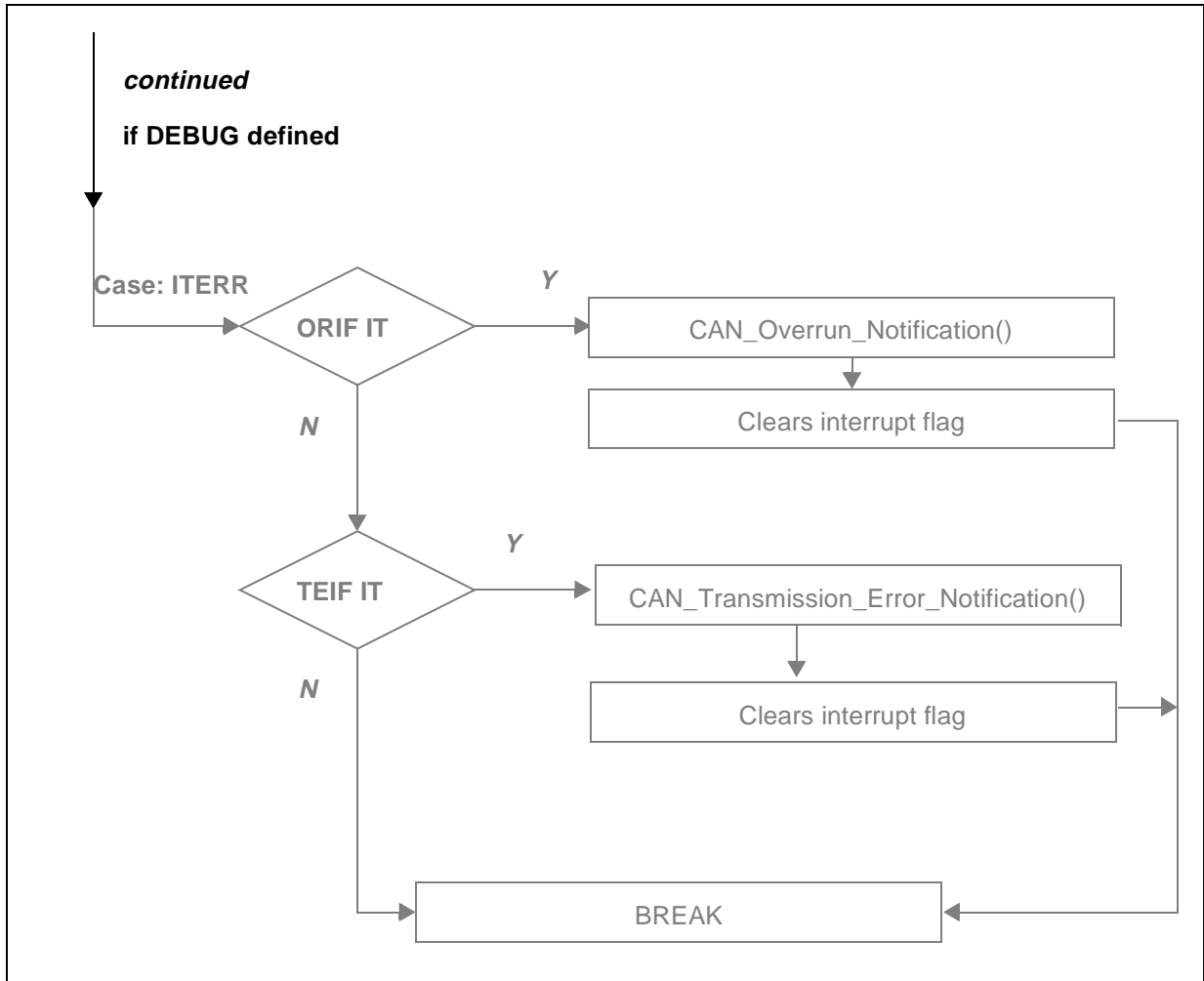

3.3 A FEW WORDS ABOUT DRIVER PERFORMANCE

3.3.1 CPU Load

Let's imagine the following situation:

- Bus rate: 100 kilobauds
- Bus load: 80%
- F_{CPU} : 8 MHz
- 14 identifiers (typical value) have to be received.

Let's measure the time spent inside the interrupt function when a message is received. The application processing inside the notification functions must be minimal: they only return a buffer to be filled.

We retrieve the following results:

- 8 bytes data message, filter match: 105 μ s
- 0 bytes data message, filter match: 90 μ s
- Any message, filter no match: 50 μ s

Note: Any message, if only the eight most significant bits match, takes 100 μ s. That is to say almost as much time as with matching identifier. So it is better to choose the identifiers wisely, in order to prevent this from occurring as much as possible.

The longest possible message (2.0A standard) is 130 bits long (including stuffing bits). Imagine that all messages on the bus are that long. Consequently, there will be 615 messages per second on the bus, that's to say one message every 1.625 μ s. The saving of data lasts 105 μ s, so the CPU load is in this case 6.5%.

The same calculation for 0-byte messages (shortest possible) leads us to 15.3% CPU load.

Note that these are worst case scenarios! Not all the messages on the bus have to be saved. And the bus load chosen here is pretty heavy (typical values are rather around 40%).

Do not forget to multiply or divide these values if you want an estimation of CPU load under other bus speed/bus loading conditions and other F_{CPU} speeds.

3.3.2 Code Size

The numbers given here correspond to the size of the driver code WITHOUT any addition of application specific code.

3.3.2.1 Can.o Module

Table 2. Can.o Code Size

	ROM	RAM (page 0)	RAM (Default)
Functions	1326 bytes	--	--
Variables & Constants	10 bytes	19 bytes (shared segment)	28 bytes

3.3.2.2 Can_custom.o Module

Table 3. Can_custom.o Code Size

	ROM	RAM (page 0)	RAM (Default)
Functions	5 bytes	--	--
Variables & Constants	--	--	--

ST7 pCAN PERIPHERAL DRIVER

```
//Compilation options coherence check

#ifndef DEBUG
    #ifdef GENERAL_RECEPTION_ERROR
        #error "Debug not defined in CAN_custom.h"
    #endif
    #ifdef SIMULTANEOUS_EMISSION_RECEPTION
        #error "Debug not defined in CAN_custom.h"
    #endif
#endif

#ifdef GENERAL_RECEPTION_ERROR
    #ifdef STATUS_CHANGE_NOTIFICATION
        #error "GENERAL_RECEPTION_ERROR and
STATUS_CHANGE_NOTIFICATION incompatibles in CAN_custom.h"
    #endif
#endif

/
*#####*/
/*          CONSTANTS ALIAS          */
/
*#####*/

#define PAGE_1 1      /* */
#define PAGE_2 2      /* CAN */
#define PAGE_3 3      /* pages */
#define PAGE_FILTERS 4 /* */

#define RECEPTION_2 2 /*Receptions buffers*/
#define RECEPTION_3 3

#define MAX_FIFO_SIZE 3 /*Size of the emission FIFO*/

#define RECEPT_MASK 0xC0 /*Masks */
#define TRANSMIT_MASK 0x10 /*to retrieve specific*/
#define SCIF_MASK 0x08 /*IT flags */
#define ERROR_MASK 0x01

#define FILTER_SHIFT 1 /*Shift applied to the identifiers managed by software
```

```
*/
// to give them the correct hardware format
#define REMOTE_BIT 5 /*Place of the remote bit in the ID field*/

#define REGISTER_SIZE 8 /*Size of a register*/

/
*#####*/
/* STRUCTURES TYPEDEF */
/
*#####*/

//Transmission queue element
typedef struct FIFO_Object{ // Definition of the reception FIFO unit
    CAN_Buffer* message; // Pointer to a CAN message structure
    struct FIFO_Object* next_object; // Pointer to the following object
in the queue
    struct FIFO_Object* preceding_object; // Pointer on the
preceding object in the queue
}FIFO_Object; //

//Transmission queue
typedef struct { // Definition of the reception FIFO type
    u8 fifo_size; // Size of the FIFO
    FIFO_Object* first_object; // Next object to be outqueued
    FIFO_Object* last_object; // Next place to fill
    CAN_Bool isinuse; // Data sharing control
} FIFO;

#ifdef FILTERS_ENABLED
//Filtering results
typedef enum {CAN_FILTER_MATCH,CAN_FILTER_NO_MATCH}CAN_Filter_Status;
#endif
//IT types
typedef enum {ITERR,ITRECEPT,ITTRANSMIT,ITSCIF}IT_Type;
//Clean error codes
typedef enum
{CAN_CLEAN_FATAL,CAN_CLEAN_SUCCESS,CAN_CLEAN_FAILURE}CAN_Clean_Error;

/
*#####*/
/* VARIABLES */
*/
```

ST7 pCAN PERIPHERAL DRIVER

```
/
*#####*/

//Static variables

//Transmission queue
static FIFO CAN_transmit_queue;
static FIFO_Object CAN_queue_object_1;
static FIFO_Object CAN_queue_object_2;
static FIFO_Object CAN_queue_object_3;

volatile static u8 status_counter=0; //this counter is used by the sleep func-
tion to determine the state

//of the reception and emission reg-
isters

//It is used the following way :
//+1 when a reception IT is taken into account
//-1 when a received buffer is released
//+1 when a message is put into emission queue
//-1 when a message is sent (in the IT function)
//This is not a shared data, so no particular protection

/
*#####*/
/*          CONSTANTES          */
/
*#####*/

#ifdef FILTERS_ENABLED

const u16 i_filters[]=INIT_FILTERS; // Initialization of the filters

const u8 CAN_Filters_Array_Size=Size_Of_Words_Array(i_filters); // is defined
in can_hr.h

// Conditionnal compi-
lation : only if FILTERS_ENABLED

// the datas are then stored
into ROM

#endif

const Init_Data first_init_data={INIT_BRPR, //That structure is written by the
preprocessor
```

```

INIT_BTR, //and stored into ROM. It can't be
modified then.

INIT_FHR0, //But can be accessed (defined as ex-
ternal in can.h)

INIT_FLR0,
INIT_MHR0,
INIT_MLR0,
INIT_FHR1,
INIT_FLR1,
INIT_MHR1,
INIT_MLR1,
};

/
*#####*/
/*          FUNCTIONS          */
/
*#####*/

////////////////////////////////////
//Notification functions////////////////////////////////////
////////////////////////////////////

CAN_Buffer* CAN_Request_Buffer(u16);

void CAN_Data_Reception_Notification(u16);
void CAN_Remote_Reception_Notification(u16);
void CAN_Transmission_Notification(void);
void CAN_Dominant_Bit_Reception_Notification(void);

#ifdef DEBUG
void CAN_Overrun_Notification(void);
void CAN_Transmission_Error_Notification(CAN_Transmit_Error);
void CAN_Reception_Status(CAN_Receive_Error);
#endif
#ifdef GENERAL_RECEPTION_ERROR
void CAN_General_Reception_Error_Notification(void);
#endif

#ifdef STATUS_CHANGE_NOTIFICATION
void CAN_Bus_Passive_Notification(void);
void CAN_Bus_Active_Notification(void);

```

ST7 pCAN PERIPHERAL DRIVER

```
void CAN_Bus_Off_Notification(void);
#endif
```

```
//////////
//can.c static functions//
//////////
#ifdef FILTERS_ENABLED
/*-----
ROUTINE NAME : CAN_Filter
INPUT/OUTPUT : identifier code/error status

DESCRIPTION : Tests matching of IDs of received messages and software filters.

COMMENTS   : Called by CAN_Recept
              Compiled only if FILTERS_ENABLED is set.
              Possible returned status : CAN_FILTER_MATCH
                                      CAN_FILTER_NO_MATCH
-----*/
static CAN_Filter_Status CAN_Filter(u16 ident_code)
{
    u8 current_first;
    u8 current_last;
    u8 current_checked;
    int current_content;

    current_first = 0;
    current_last = CAN_Filters_Array_Size - 1;

    for (;;)
    {
        current_checked = (u8)(current_first + current_last) >> 1;
        current_content = i_filters[current_checked] - ident_code;

        if (current_content < 0)
        {
            current_first = current_checked + 1;
            if (current_first > current_last)
                break;
        }
    }
}
```

```

        }
    else if (current_content == 0)
    return (CAN_FILTER_MATCH);
    else
        {
            current_last = current_checked - 1;
            if (current_last < current_first)
                break;
        }
    }
return (CAN_FILTER_NO_MATCH);
}

#endif /*ifdef FILTERS_ENABLED*/

/*-----
ROUTINE NAME : CAN_Get_IT_Type
INPUT/OUTPUT : -- / generic type of the event that caused the IT

DESCRIPTION : IT type fetching routine

COMMENTS : Called by CAN_Interrupt
           Possible status returned : ITRECEPT for reception IT
                                   ITTRANSMIT for transmission IT
                                   ITERR for error IT
-----*/

static IT_Type CAN_Get_IT_Type(void)
{
#ifdef DEBUG /*In this case, priority is given to error detection*/
if ((ERROR_MASK & CANISR) != 0)
    {
        return ITERR;
    }
else if ((SCIF_MASK & CANISR) != 0)
    {
        return ITSCIF;
    }
#endif

#endif

#ifdef STATUS_CHANGE_NOTIFICATION /*In this case, prioity given to status change,
eg. to early detect bus-off state*/
#ifdef DEBUG /*If debug is defined, this IT has already been
taken into account*/

```

ST7 pCAN PERIPHERAL DRIVER

```
if ((SCIF_MASK & CANISR)!=0)
    {
        return ITSCIF;
    }
#endif
#endif

if ((RECEPT_MASK & CANISR)!=0) //If not debug, priority is given to recept.,
then emission, then Status-Change/Wake-up condition//
    {
        return ITRECEPT;
    }
else if ((TRANSMIT_MASK & CANISR)!=0) //If not, tests a transmit. IT
    {
        return ITTRANSMIT;
    }

#ifndef DEBUG //In this case, this IT hasn't been tested yet*/
#ifndef STATUS_CHANGE_NOTIFICATION
else if ((SCIF_MASK & CANISR)!=0)
    {
        return ITSCIF;
    }
#endif
#endif
}

/*-----*/
```

ROUTINE NAME : CAN_Init

INPUT/OUTPUT : Pointer on an init structure/Error status

DESCRIPTION : CAN cell internal registers initialization

COMMENTS : Called by CAN_Switch_On,CAN_First_Init

Not executed if RUN bit reset

Possible status returned : CAN_INIT_FAILURE

CAN_INIT_SUCCESS

```
-----*/
CAN_Init_Error CAN_Init(Init_Data_Ptr data_ptr,CAN_Bool run_set,CAN_Bool
wkup_set)
{
    if (!ValBit(CANCSR,RUN))
```

```
{
  /*Registers init*/
  CANBRPR=data_ptr->brpr_init;//Init of timing variables
  CANBTR=data_ptr->btr_init;

  //Reset CANISR register
  CANISR = 0x00;

  //Calculation of the CANICR value
  CANICR=0x30;          //Default value : recept., transmit.
#ifdef STATUS_CHANGE_NOTIFICATION
  CANICR=CANICR|0x08; //A bus wake up may not be wished, but a status change
monitoring is wanted
#endif
#ifdef DEBUG
  CANICR=CANICR|0x06;
#endif
#ifdef GENERAL_RECEPTION_ERROR
  CANICR=CANICR|0x40; //Sets the ESCI bit & the SCIF bit
#endif /*GENERAL_RECEPTION_ERROR*/

  //Select filters/masks page
  CANPSR=PAGE_FILTERS;

  CANMLR0=data_ptr->mlr0_init;
  CANMHR0=data_ptr->mhr0_init;
  CANFLR0=data_ptr->flr0_init;
  CANFHR0=data_ptr->fhr0_init;

  CANMLR1=data_ptr->mlr1_init;
  CANMHR1=data_ptr->mhr1_init;
  CANFLR1=data_ptr->flr1_init;
  CANFHR1=data_ptr->fhr1_init;

  /*Calculation of the CANCSR register value*/
  CANCSR=0x00;

  if (wkup_set)
  {
    SetBit(CANCSR,WKPS);
  }
#ifdef SIMULTANEOUS_EMISSION_RECEPTION
```

ST7 pCAN PERIPHERAL DRIVER

```
SetBit(CANCSR,SRTE);
#endif /*SIMULTANEOUS_EMISSION_RECEPTION*/
if (run_set)
{
CAN_RUN_Cell();
}
return CAN_INIT_SUCCESS;
}

else {
return CAN_INIT_FAILURE;
}

}

/*-----
ROUTINE NAME : CAN_In_Queue
INPUT/OUTPUT : pointer on a CAN buffer
output error code

DESCRIPTION : Put a message given by the application into the transmission queue
Updates the queue parameters

COMMENTS : Called by CAN_Transmit_Request
Must not be interrupted
Possible return values : CAN_FIFO_FULL
CAN_TRANSMIT_SUCCESS
CAN_TRANSMIT_FATAL
-----*/
static CAN_Transmit_Error CAN_In_Queue (CAN_Buffer* msg_to_queue)
{

if (CAN_transmit_queue.isinuse) //Necessary to avoid multiple simultaneous
access
{
return CAN_TRANSMIT_FATAL; //Time out ?
} //to the datas

CAN_transmit_queue.isinuse=CTRUE; //Locks the queue

if ((CAN_transmit_queue.fifo_size)>=MAX_FIFO_SIZE) //Tests if the FIFO is
already full
{
CAN_transmit_queue.isinuse=CFALSE; //If yes, releases the queue
return CAN_FIFO_FULL; //...and aborts process
}
```

```

    }
else
    {
        //If not, goes on processing

        CAN_transmit_queue.last_object=(CAN_transmit_queue.last_object-
>next_object);
        CAN_transmit_queue.last_object->message=msg_to_queue;
        CAN_transmit_queue.fifo_size=(CAN_transmit_queue.fifo_size)+1;

        CAN_transmit_queue.isinuse=CFALSE;
        return CAN_TRANSMIT_SUCCESS;           //Releases the queue
    }
}

/*-----
ROUTINE NAME : CAN_Out_Queue
INPUT/OUTPUT : -- /pointer on a CAN buffer

DESCRIPTION : Returns a pointer on the first message in the transmission queue.
              Update the queue parameters

COMMENTS    : Called by CAN_TransmitRequest
              Must not be interrupted

-----*/
static CAN_Buffer* CAN_Out_Queue (void)
{
    CAN_Buffer* result;

    if (CAN_transmit_queue.isinuse) //Necessary to avoid multiple simultaneous
access
    {
        //to the datas
        return CAN_TRANSMIT_FATAL; //CAN_TRANSMIT_FATAL=0, that's why the compiler
authorises such a return value (<=>NULL)
    }

    CAN_transmit_queue.isinuse=CTRUE; //Locks the queue
    if ((CAN_transmit_queue.fifo_size)==0) //If the queue is empty
    {
        CAN_transmit_queue.isinuse=CFALSE; //Releases it
        return NULL;
    }
else
    {
        //Else goes on processing

```

ST7 pCAN PERIPHERAL DRIVER

```
    result=CAN_transmit_queue.first_object->message;

    CAN_transmit_queue.first_object->message=NULL;    //Updates queue
parameters
    CAN_transmit_queue.first_object=CAN_transmit_queue.first_object-
>next_object;
    CAN_transmit_queue.fifo_size=(CAN_transmit_queue.fifo_size)-1;

    CAN_transmit_queue.isinuse=CFALSE;    //Releases the queue
    return result;
}
}

/*-----
ROUTINE NAME : CAN_Clean
INPUT/OUTPUT : -- /error status

DESCRIPTION : Cleans the receipt. and emission buffers, and resets the transmis-
sion queue.

COMMENTS : Must be called only in sleep mode (run bit reset)
          Must not be interrupted
          Only affects pointers
          Called by CAN_Sleep and CAN_Kill
          Possible return values : CAN_CLEAN_FAILURE
                                CAN_CLEAN_SUCCESS
                                CAN_CLEAN_FATAL
-----*/
static CAN_Clean_Error CAN_Clean (void)
{

if (!ValBit(CANCSR,RUN))    //No cleaning while the CAN node is running
{
    //Cleaning transmission queue
    if (CAN_transmit_queue.isinuse)
    {
        return CAN_CLEAN_FATAL;
    }
    CAN_transmit_queue.isinuse=CTRUE;    //Locks the queue
    CAN_transmit_queue.first_object=&CAN_queue_object_1; //Reinit. the
queue
    CAN_transmit_queue.last_object=&CAN_queue_object_3; //(In the same
```

```

state than after 1st. init
    CAN_transmit_queue.fifo_size=0;

    CAN_queue_object_1.message=NULL;
    CAN_queue_object_2.message=NULL;
    CAN_queue_object_3.message=NULL;

    CAN_transmit_queue.isinuse=CFALSE;//Releases the queue
    //Hardware cleaning (releases the hardware buffers)
    CANPSR=PAGE_3;
    while (CANPSR>0)
    {
        Clr_RDY_Bit();
        CANPSR--;
    }

    //IT cleaning : clears any pending IT flag
    CANISR=CANISR&0;
    return CAN_CLEAN_SUCCESS;

}

else
{
    return CAN_CLEAN_FAILURE;
}
}

/*-----
ROUTINE NAME : CAN_Fill_Transmission_Buffer
INPUT/OUTPUT : -- / error status

DESCRIPTION : Fills the hardware buffer for transmission.

COMMENTS : ITs have to be disabled
           Called by CAN_Transmit_Request
           Calls CAN_Out_Queue
           Possible return values : CAN_TRANSMIT_BUFFER_FULL
                                   CAN_TRANSMIT_NO_MSG
                                   CAN_TRANSMIT_SUCCESS
-----*/
CAN_Transmit_Error CAN_Fill_Transmission_Buffer(void)
{
    CANPSR=PAGE_1;

```

ST7 pCAN PERIPHERAL DRIVER

```
if (ValBit(CANBCSR, RDY)) //Check if the register is already in use
{
    return CAN_TRANSMIT_BUFFER_FULL; //Exit if yes
}
else
{
    CAN_Buffer* msg_to_send_ptr;
    u8* data_ptr;
    CAN_Data_Size data_length;

    msg_to_send_ptr=CAN_Out_Queue(); //If no, get the first message
in the queue
    if (msg_to_send_ptr==NULL)
    {
        return CAN_TRANSMIT_NO_MSG; //Aborts process if queue
empty
    }

    CANIDLR=0x00;
    CANIDHR=0x00;

    data_length=msg_to_send_ptr->data_size;
    data_ptr=msg_to_send_ptr->CAN_msg_data;

    //!!!Code is here dependant of the order of the fields in the data structure
    //Writing both CANIDHR and CANIDLR

    CANIDLR = (((unsigned char*)msg_to_send_ptr)+1);
    CANIDHR = ((unsigned char*)msg_to_send_ptr);
    _asm("SLL _CANIDLR \n RLC _CANIDHR");

    {
        register u8 counter;

        if (data_length==REMOTE_FRAME) /*If remote frame, send immediately*/

        {
            SetBit(CANIDLR, RTR);
        }
        else
        {

            CANIDLR |= data_length;
            for (counter=0; counter<data_length; counter++)
            {
```

```

        CANDR[counter]=data_ptr[counter];
    }
}
counter=7;
CANDR[7]=data_ptr[counter];
}
msg_to_send_ptr->buffer_free=CTRUE;
msg_to_send_ptr->buffer_rw=CFALSE;
}
return CAN_TRANSMIT_SUCCESS;
}

/*-----
ROUTINE NAME : CAN_Store_Rcvd_Msg
INPUT/OUTPUT : ID of the buffer to void/Status message

DESCRIPTION : Fetches the datas received in a hardware buffer.

COMMENTS : ITs have to be disabled
           This fuction is called by CAN_Recept, only in case of reception of datas
           Priority given to SPEED here, that's why the code may look strange
           Possible return values : CAN_ILLEGAL_IDENTIFIER
                                   CAN_RECEIVE_SUCCESS
-----*/

static CAN_Receive_Error CAN_Store_Rcvd_Msg(CAN_Buffer* dest_ptr)
{
u8* data_ptr;
u8 data_size;

//CANPSR=num_buff_hard;
data_ptr=(dest_ptr->CAN_msg_data);

data_size=(CANIDLR&0x0F);
if(data_size>8)
{
Clr_RDY_Bit();
return CAN_ILLEGAL_IDENTIFIER;
}

dest_ptr->data_size=data_size;//Saving data size

{
register u8 counter;

```

ST7 pCAN PERIPHERAL DRIVER

```
for (counter=0;counter<data_size;counter++)
    {
        data_ptr[counter]=CANDR[counter];
    }
}

Clr_RDY_Bit();    //Releases the buffer and clears the IT flag

return CAN_RECEIVE_SUCCESS;
}

/*-----
ROUTINE NAME : CAN_Receive

INPUT/OUTPUT : ID of the buffer to void/Status message

DESCRIPTION : Fetches the datas received in a hardware buffer and saves them in a
soft buffer
                furnished by the application.

COMMENTS    : ITs have to be disabled
                Calls CAN_Filter (optionnal)
                CAN_Request_Buffer
                CAN_Store_Rcvd_Msg
                Possible return values : CAN_FILTERING_FAILURE
                                        CAN_NO_BUFFER
                                        CAN__RECEIVE_FATAL
                                        CAN_RECEIVE_SUCCESS
-----*/

static CAN_Receive_Error CAN_Receive(u8 num_buff_hard)
{
    CAN_Buffer* soft_buffer_ptr;
    CAN_Receive_Error receive_status;
    u16 message_ident;

#ifdef FILTERS_ENABLED    /*Conditional compilation*/
    CAN_Filter_Status filtering_status;
#endif

    //Retrieving the ID of the message
    CANPSR=num_buff_hard;
```

```
message_ident = (((unsigned int)CANIDHR)<<8)|CANIDLR;

message_ident >= FILTER_SHIFT; //Appropriate righth shift
message_ident &= 0xFFF0;

//Filtering function
#ifdef FILTERS_ENABLED /*Conditionnal compilation*/
filtering_status=CAN_Filter(message_ident); //Filtering fonction call
if (filtering_status==CAN_FILTER_NO_MATCH)
{
    Clr_RDY_Bit(); //Frees the hardware buffer for a
new reception
    return CAN_FILTERING_FAILURE;
}
#endif

//Tests if remote frame
if(ValBit(CANIDLR,4))
{
    Clr_RDY_Bit();
    CAN_Remote_Reception_Notification(message_ident);
    return CAN_RECEIVE_REMOTE;
}
//Else, saves the datas in a buffer passed by the application

soft_buffer_ptr=CAN_Request_Buffer(message_ident); //Requests a buffer for
the message that successfully passed the filters
if (soft_buffer_ptr==NULL) //The buffer must exist prior to beeing filled
!!!
{
    Clr_RDY_Bit();
    return CAN_NO_BUFFER; //Kind of "software overrun"
}

if (soft_buffer_ptr->buffer_rw)
{
    Clr_RDY_Bit();
    return CAN_RECEIVE_FATAL;
}

soft_buffer_ptr->buffer_rw=CTRUE; //Locks the buffer

if (!(soft_buffer_ptr->buffer_free))
{
```

ST7 pCAN PERIPHERAL DRIVER

```
    Clr_RDY_Bit();
    soft_buffer_ptr->buffer_rw=CFALSE;//If the buffer is full, releases it
    return CAN_RECEIVE_FATAL;        //and exit
}

receive_status=CAN_Store_Rcvd_Msg(soft_buffer_ptr); //Saves message and re-
leases the hardware buffer
//Writing identifier :
*(int*)soft_buffer_ptr = message_ident;

//End of routine :
if (receive_status!=CAN_RECEIVE_SUCCESS)
{
    Clr_RDY_Bit();
    soft_buffer_ptr->buffer_rw=CFALSE;//In case of failure, releases the
buffer and exits
    return CAN_RECEIVE_FATAL;
}

soft_buffer_ptr->buffer_free=CFALSE; //In case of success, marks the buffer
as in use
soft_buffer_ptr->buffer_rw=CFALSE; //Unlock it
CAN_Data_Reception_Notification(message_ident);

return CAN_RECEIVE_SUCCESS;
}

/*-----
ROUTINE NAME : CAN_Interrupt
INPUT/OUTPUT : -- /--

DESCRIPTION : interrupt processing function

COMMENTS : Each case must be taken into account.
Calls     CAN_Get_IT_Type
          CAN_Reception_Notification
          CAN_Transmission_Notification
          CAN_Fill_Transmission_Buffer
          CAN_Dominant_Bit_Reception_Notification
May call (optionnal) :
          CAN_Transmission_Error_Notification
          CAN_Bus_Passive_Notification
          CAN_Bus_Active_Notification
          CAN_Bus_Off_Notification
```

```

        CAN_Overrun_Notification
        CAN_General_Reception_Error_Notification
-----*/
@interrupt @nostack void CAN_Interrupt(void)
{
    IT_Type it_type;

    it_type=CAN_Get_IT_Type();

switch(it_type)
    {
        case ITRECEPT :
            {
                CAN_Receive_Error error_status;

                if (ValBit(CANISR,RXIF3)) //Check the lower priority buffer
first
                    {
                        status_counter=status_counter+1;
                        error_status=CAN_Receive(RECEPTION_3);
                        #ifdef DEBUG
                        CAN_Reception_Status(error_status);
                        #endif
                        status_counter=status_counter-1;
                    }
                if(ValBit(CANISR,RXIF2)) //Then checks the other
                    {
                        status_counter=status_counter+1;
                        error_status=CAN_Receive(RECEPTION_2);
                        #ifdef DEBUG
                        CAN_Reception_Status(error_status);
                        #endif
                        status_counter=status_counter-1;
                    }
                break;
            }
        case ITTRANSMIT :    //Transmission IT
            {
                CAN_Transmit_Error status;

                Clr_TXIF_Bit();//Clearing the flag

                status_counter=status_counter-1;    //Decrementing the
status counter
            }
    }
}

```

ST7 pCAN PERIPHERAL DRIVER

```
CAN_Transmission_Notification();
    status=CAN_IT_Fill_Transmission_Buffer();
#ifdef DEBUG
    if (status!=CAN_TRANSMIT_SUCCESS)
        {
            CAN_Transmission_Error_Notification(status); //
When an unsuccessfull transmission occurred (argument : error status?)
        }
#endif
break;
}
case ITSCIF :
{
    CAN_Status status;

    Clr_SCIF_Bit();
    status=CAN_Get_Status();
    if (status==CAN_STANDBY)
        {
            CAN_Dominant_Bit_Reception_Notification(); //Re-
reception of a dominant bit while in stanby mode
#ifdef STATUS_CHANGE_NOTIFICATION
            ClrBit(CANICR,SCIE); //After first init, this IT is
no more needed if
#endif
/*STATUS_CHANGE_NOTIFICATION is not requested*/
        }
#ifdef STATUS_CHANGE_NOTIFICATION
    switch (status)
        {
            case CAN_BUS_PASSIVE :
                CAN_Bus_Passive_Notification(); //Status change to
bus passive
                break;
            case CAN_BUS_ACTIVE :
                CAN_Bus_Active_Notification(); //Status change to
bus active
                break;
            case CAN_BUS_OFF :
                CAN_Bus_Off_Notification(); //Response to a status
change to bus-off
                break;
            default :
                ///////////////////////////////////
```

```

        //Default case//////////
        //Should never happen////
        //Write debug code here//
        ////////////
        break;
    }
#endif
#ifdef GENERAL_RECEPTION_ERROR
{
    CAN_General_Reception_Error_Notification();
    Clr_SCIF_Bit();
}
#endif
    break;
}

#ifdef DEBUG
case ITERR :
{
    if (ValBit(CANISR,ORIF))
    {
        CAN_Overrun_Notification();
        Clr_ORIF_Bit();
    }
    else if (ValBit(CANISR,TEIF))
    {

CAN_Transmission_Error_Notification(CAN_TRANSMISSION_ERROR_IT);
        Clr_TEIF_Bit();
    }

    break;
}
#endif
default :
    ////////////
    //Default case (should never be reached)//
    //Debug code////////////////////////////////////
    ////////////
    break;
}
}

```

/* PUBLIC FUNCTIONS

ST7 pCAN PERIPHERAL DRIVER

```
*****/
/* List of all functions defined in this module and used in other modules */

/*-----
ROUTINE NAME : CAN_Get_TEC()
INPUT/OUTPUT : -/Value of the TECR register (transmission error counter)

DESCRIPTION : Returns the value of the TECR register

COMMENTS   :

-----*/

u8 CAN_Get_TEC(void)
{
    return CANTECR;
}

/*-----
ROUTINE NAME : CAN_Get_REC()
INPUT/OUTPUT : -/Value of the RECR register (reception error counter)

DESCRIPTION : Returns the value of the TECR register

COMMENTS   :

-----*/

u8 CAN_Get_REC(void)
{
    return CANRECR;
}

/*-----
ROUTINE NAME : CAN_Get_Status
INPUT/OUTPUT : -- / current status of the cell

DESCRIPTION : Retrieves the current status of the CAN cell.

COMMENTS   : Possible return values : CAN_STANDBY
                                         CAN_BUS_PASSIVE
                                         CAN_BUS_OFF
                                         CAN_BUS_ACTIVE
-----*/
CAN_Status CAN_Get_Status (void)
```

```

{
    if (!ValBit(CANCSR,RUN))
    {
        return CAN_STANDBY;
    }
    else
    {
        if (ValBit(CANCSR,EPV))
        {
            return CAN_BUS_PASSIVE;
        }
        else
        {
            if (ValBit(CANCSR,BOFF))
            {
                return CAN_BUS_OFF;
            }
            else return CAN_BUS_ACTIVE;
        }
    }
}

```

```

/*-----
ROUTINE NAME : CAN_First_Init
INPUT/OUTPUT : --/ error status

DESCRIPTION : Can Cell power on initialisation Routine.

COMMENTS    : Calls CAN_Init
              Possible return value : CAN_INIT_FAILURE
              CAN_INIT_SUCCESS
-----*/

```

```

CAN_Init_Error CAN_First_Init(void)
{
    if (!ValBit(CANCSR,RUN))    //The CAN node is not running and there is an init
structure
    {
        CAN_Bool run_set,wkps_set;

        /*Transmiton queue init*/

```

ST7 pCAN PERIPHERAL DRIVER

```
        CAN_queue_object_1.next_object=&CAN_queue_object_2;           //The
transmission objects are being linked
        CAN_queue_object_1.preceding_object=&CAN_queue_object_3;
        CAN_queue_object_1.message=NULL;

        CAN_queue_object_2.next_object=&CAN_queue_object_3;
        CAN_queue_object_2.preceding_object=&CAN_queue_object_1;
        CAN_queue_object_2.message=NULL;

        CAN_queue_object_3.next_object=&CAN_queue_object_1;
        CAN_queue_object_3.preceding_object=&CAN_queue_object_2;
        CAN_queue_object_3.message=NULL;

        CAN_transmit_queue.fifo_size=0;
        CAN_transmit_queue.first_object=&CAN_queue_object_1;
        CAN_transmit_queue.last_object=&CAN_queue_object_3; //Has to be initial-
ized that way, or the first input will fail

        CAN_transmit_queue.isinuse=CFALSE;                           //Releases queue

CANPSR=PAGE_1;
Clr_LOCK_Bit(); //Cancels any pending transmission
        SetBit(CANBCSR,LOCK); //Thus the buffer 2 cannot be used for
reception

        //Init of the hardware buffers
run_set=CFALSE;
#ifdef RUN_ON_START_UP
run_set=CTRUE;
#endif
wkps_set=CFALSE;
#ifdef WAKE_UP_PULSE
wkps_set=CTRUE;
#endif
status_counter=0;

#ifdef RUN_ON_START_UP
CANICR=CANICR|0x08; //ie. a bus wake-up is wished
#endif

        if(CAN_1_Init(&first_init_data,run_set,wkps_set)==CAN_INIT_FAILURE)
```

```

        {
            return CAN_INIT_FAILURE;
        }
    return CAN_INIT_SUCCESS;

}
else return CAN_INIT_FAILURE;
}

/*-----
ROUTINE NAME : CAN_It_Dis
INPUT/OUTPUT : --/--

DESCRIPTION : Reset of the CANICR register.

COMMENTS   :

-----*/

void CAN_It_Dis (void)
{
    CANICR=0x00;
}

/*-----
ROUTINE NAME : CAN_Switch_Off
INPUT/OUTPUT : way the chip can be waken up : BUS_WAKEUP or SOFT_WAKEUP/error
status

DESCRIPTION : Puts the CAN node into standby state. Aborts any pending transmis-
sion
                and doesn't wait for the reception buffer to having been read.
                A time out mechanism is implemented here (about 30ms). So if
you use the
                watchdog in your application, REFRESH IT BEFORE CALLING THE
FUCNTION !

COMMENTS   : Calls CAN_Clean
                Possible return value : CAN_SLEEP_SUCCESS
                CAN_SLEEP_FATAL
-----*/

CAN_Switch_Error CAN_Switch_Off (WakeUp_Cause wucause)

```

ST7 pCAN PERIPHERAL DRIVER

```
{
CAN_Clean_Error clean_status;

CAN_It_Dis();           //Resets the CANICR register

ClrBit(CANCSR,RUN);

while (ValBit(CANCSR,RUN))
{
static ul6 counter=0xFFFF; //Implement here a time out (171990 CPU cycles,
~21,4ms with 8MHz fcpu)

counter=counter-1;
if (counter==0)
{
return CAN_SLEEP_FATAL;
}

}
clean_status=CAN_Clean();
if (clean_status==CAN_CLEAN_FAILURE)
{
return CAN_SLEEP_FATAL;
}
if (wucause==BUS_WAKEUP) //We are then in the case when the uC has to be
waken up by the bus
{
Clr_SCIF_Bit(); //clears the CANISR TXIF flag, before reenabling ITs
SetBit(CANICR,SCIE); //sets the CANICR TXIE flag, before reenabling ITs
}
else if(wucause==SOFT_WAKEUP)
{
Clr_SCIF_Bit(); //clears the CANISR TXIF flag, before reenabling ITs
}

status_counter=0;
return CAN_SLEEP_SUCCESS;
}

/*-----
ROUTINE NAME : CAN_Sleep
INPUT/OUTPUT : way the chip can be waken up : BUS_WAKEUP or SOFT_WAKEUP/Error
status
```

DESCRIPTION : Puts the CAN node into passive state. Returns an error if any transmission request is pending or if a hardware reception buffer is still unsaved. Dedicated to bus wake-up (for power save).

COMMENTS : Doesn't call CAN_Clean.
Possible return values : CAN_SLEEP_ERROR
CAN_SLEEP_FATAL
CAN_SLEEP_SUCCESS

-----*/

```

CAN_Switch_Error CAN_Sleep (WakeUp_Cause wucause)
{
    if (status_counter==0)
    {
        CANPSR=PAGE_2;
        SetBit(CANBCSR,LOCK);
        if (!ValBit(CANBCSR,LOCK))
        {
            return CAN_SLEEP_ERROR;
        }
        CANPSR=PAGE_3;
        SetBit(CANBCSR,LOCK);
        if (!ValBit(CANBCSR,LOCK))
        {
            CANPSR=PAGE_2;
            Clr_LOCK_Bit();
            return CAN_SLEEP_ERROR;
        }

        //Then the CAN cell can be shut down
        ClrBit(CANCSR,RUN);
        if (ValBit(CANCSR,RUN)) //Be careful there !!!!!
        {
            return CAN_SLEEP_FATAL;
        }
        CANPSR=PAGE_2;
        Clr_LOCK_Bit();
        CANPSR=PAGE_3;
        Clr_LOCK_Bit();
        if (wucause==BUS_WAKEUP) //We are then in the case when the uC has to
        be waken up by the bus
    }
}

```

ST7 pCAN PERIPHERAL DRIVER

```
        {
        Clr_SCIF_Bit();    //clears the CANISR TXIF flag, before
reenabling ITs
        SetBit(CANICR,SCIE);    /*sets the CANICR TXIE flag, before
reenabling ITs*/
        }
    else if(wucause==SOFT_WAKEUP)
    {
    Clr_SCIF_Bit();    //clears the CANISR TXIF flag, before
reenabling ITs
    }
}
```

```
    return CAN_SLEEP_SUCCESS;
}
```

```
return CAN_SLEEP_ERROR;    //default exit
}
```

```
/*-----
ROUTINE NAME : CAN_Switch_on
INPUT/OUTPUT : pointer on an init data, order : emission of a dominant pulse by
wake up or not/error status

DESCRIPTION : Puts the CAN node into active state

COMMENTS : Calls CAN_Init
           Possible return value : SWITCH_ON_SUCCES
                                   SWITCH_ON_FAILURE
-----*/
```

```
CAN_Switch_Error CAN_Switch_On (Init_Data_Ptr idptr, CAN_Bool wupulse_allowed)
{
```

```
    if (!ValBit(CANCSR,RUN)) //The can must not be running
    {
        CAN_Switch_Error error_status;

        status_counter=0;

        CANPSR=PAGE_1;
        Clr_LOCK_Bit();    //Cancels any pending transmission
        SetBit(CANBCSR,LOCK);    //Thus the buffer 1 cannot be used for reception
```

```

        if (idptr!=NULL)          //If NULL, nothing will be reinitialized
        {
            error_status=CAN_Init(idptr,CTRUE,wupulse_allowed); //RUN set automat-
ically
            if (error_status==CAN_INIT_FAILURE)
                {
                    return CAN_SWITCH_ON_FAILURE;
                }
        }

        return CAN_SWITCH_ON_SUCCES;
    }

```

```

else return CAN_SWITCH_ON_FAILURE;
}

```

```

/*-----
ROUTINE NAME : CAN_Transmit_request

```

INPUT/OUTPUT : pointer on the CAN buffer to send/error status

DESCRIPTION : Puts a message into the queue, and may request an immediate transmission if it's void

COMMENTS : Calls CAN_Init_Queue and CAN_Fill_Transmission_Buffer

!!!This function MUST NOT be interrupted, so protect it with SIM and RIM statements when used OUTSIDE the notification fuctions of CAN_custom.c!!!

```

-----*/

```

```

CAN_Transmit_Error CAN_Transmit_Request(CAN_Buffer* msg_to_send_ptr)
{
    CAN_Transmit_Error status;

```

```

    if (msg_to_send_ptr->buffer_rw==CTRUE)
        {
            return CAN_TRANSMIT_FAILURE;
        }
    msg_to_send_ptr->buffer_rw=CTRUE;

```

```

    if (!ValBit(CANCSR,RUN))          //No transmission autorized when the CAN cell is
not running
    {

```

ST7 pCAN PERIPHERAL DRIVER

```
    msg_to_send_ptr->buffer_rw=CFALSE;
    return CAN_TRANSMIT_FAILURE;
}

status=CAN_In_Queue(msg_to_send_ptr); //Puts the message in the queue
if (status==CAN_FIFO_FULL)
{
    msg_to_send_ptr->buffer_rw=CFALSE;
    return status;
}

status_counter=status_counter+1;

status=CAN_Fill_Transmission_Buffer(); //Tries to fill the buffer 2
if (status==CAN_TRANSMIT_NO_MSG) //This should never happen
{
    status_counter=status_counter-1;
    msg_to_send_ptr->buffer_rw=CFALSE;
    return CAN_TRANSMIT_FATAL;
}
else
{
    return status; //Can be success or buffer in use (ie. a request
is already pending)
} //The modif of buffer_rw will be
executed by CAN_Store_Received_Message
}

/***** (c) 2000 STMicroelectronics *****/
```

4.2 CAN.H

```
/***** (c) 2000 STMicroelectronics *****/
PROJECT :
COMPILER : ST7 COSMIC C v4.2e

MODULE : can.h
VERSION : V 1.1.6 build 80
CREATION DATE : 04/00
```

AUTHOR : Central Europe 8bit Micro Application Group

DESCRIPTION : CAN routines

MODIFICATIONS : none

THE SOFTWARE INCLUDED IN THIS FILE IS FOR GUIDANCE ONLY. ST MICROELECTRONICS
SHALL NOT BE HELD LIABLE FOR ANY DIRECT, INDIRECT OR CONSEQUENTIAL DAMAGES
WITH RESPECT TO ANY CLAIMS ARISING FROM USE OF THIS SOFTWARE.
***** /

```
#ifndef CAN_H
#define CAN_H
```

```
#define CAN_MAX_DATA_SIZE 8
```

```
#ifndef _H_STDDEF_
#define NULL (void*) 0 /*Not already defined if stddef.h not included*/
#endif
#define NULL_DEFINED
```

```
 /
 *#####
 */
 /*          TYPEDEF          */
 /
 *#####
 */
```

```
//////////
//Simple data types//
//////////
```

```
typedef enum {BUS_WAKEUP, SOFT_WAKEUP} WakeUp_Cause;
typedef enum
{DLC0, DLC1, DLC2, DLC3, DLC4, DLC5, DLC6, DLC7, DLC8, REMOTE_FRAME} CAN_Data_Size;
```

ST7 pCAN PERIPHERAL DRIVER

```
//Error status messages
//Initialisation
typedef enum {CAN_INIT_SUCCESS,CAN_INIT_FAILURE}CAN_Init_Error;
//Sleep
typedef enum
{CAN_SLEEP_FATAL,CAN_SLEEP_ERROR,CAN_SLEEP_SUCCESS,CAN_SWITCH_ON_SUCCES,CAN_
SWITCH_ON_FAILURE}CAN_Switch_Error;
//Status
typedef enum
{CAN_RUN,CAN_STANDBY,CAN_BUS_ACTIVE,CAN_BUS_PASSIVE,CAN_BUS_OFF}CAN_Status;
//Misc.
typedef enum {CFALSE=0,CTRUE=1}CAN_Bool;

//Transmission-Reception
typedef enum
{CAN_TRANSMIT_FATAL,CAN_TRANSMIT_SUCCESS,CAN_TRANSMIT_FAILURE,CAN_TRANSMIT_N
O_MSG,CAN_FIFO_FULL,CAN_TRANSMIT_BUFFER_FULL,CAN_TRANSMISSION_ERROR_IT}CAN_T
ransmit_Error;
typedef enum
{CAN_RECEIVE_FATAL,CAN_RECEIVE_SUCCESS,CAN_RECEIVE_REMOTE,CAN_ILLEGAL_IDENTI
FIER,CAN_FILTERING_FAILURE,CAN_BUFFER_IN_USE,CAN_NO_BUFFER,CAN_RCV_BUFFER_NO
T_READY}CAN_Receive_Error;

////////////////////////////////////
//Transmission/Reception structures //
////////////////////////////////////

//Input/output structure
typedef struct CAN_Buffer{
    u16 msg_identifrier;
    CAN_Data_Size data_size;
    u8 CAN_msg_data[CAN_MAX_DATA_SIZE];
    CAN_Bool buffer_rw;
    CAN_Bool buffer_free; //shared variable
}CAN_Buffer;

////////////////////////////////////
//Initialization parameters//
////////////////////////////////////
//Initialisation data structure
typedef struct {
    u8 brpr_init;
    u8 btr_init;
    u8 fhr1_init;
```

```
        u8 flr1_init;
        u8 mhr1_init;
        u8 mlr1_init;
        u8 fhr0_init;
        u8 flr0_init;
        u8 mhr0_init;
        u8 mlr0_init;
    }Init_Data;

typedef Init_Data* Init_Data_Ptr; // Pointer on an Init_Data structure

/
*#####*/
/*          VARIABLES          */
/
*#####*/

//Initialization of the CAN-cell
//Variables declared in can.c
extern const Init_Data first_init_data; //Initialisation datas used at power-on
extern const u16 i_filters[]; // Array of accepted filters

/
*#####*/
/*          FUNCTIONS          */
/
*#####*/

//Power-on initialisation
CAN_Init_Error CAN_First_Init(void);

//Resets IT authorization flags
void CAN_It_Dis(void);

//Gets state of the cell : active, passive, off
CAN_Status CAN_Get_Status (void);

//Gets value of Transmit Error Counter & Reception Error Counter
u8 CAN_Get_TEC(void);
u8 CAN_Get_REC(void);

//Modification of the cell state
CAN_Switch_Error CAN_Switch_Off(WakeUp_Cause);
CAN_Switch_Error CAN_Sleep (WakeUp_Cause);
CAN_Switch_Error CAN_Switch_On(Init_Data_Ptr ,CAN_Bool);
```

ST7 pCAN PERIPHERAL DRIVER

```
//Transmission request
CAN_Transmit_Error CAN_Transmit_Request(CAN_Buffer*);

/
*#####*/
/*          MACROS          */
/
*#####*/

//To clear status registers flags
#define Clr_RXIF3_Bit() (CANISR=0x7F)
#define Clr_RXIF2_Bit() (CANISR=0xBF)
#define Clr_RXIF1_Bit() (CANISR=0xDF)
#define Clr_TXIF_Bit() (CANISR=0xEF)
#define Clr_SCIF_Bit() (CANISR=0xF7)
#define Clr_ORIF_Bit() (CANISR=0xFB)
#define Clr_TEIF_Bit() (CANISR=0xFD)
#define Clr_EPND_Bit() (CANISR=0xFE)

//To clear
#define Clr_LOCK_Bit() (CANBCSR=0xFE)
#define Clr_RDY_Bit() (CANBCSR=0xFA)

#define Size_Of_Words_Array(array) sizeof(array)/sizeof(unsigned int)

/*-----CAN SETTINGS-----*/

#define CAN_RUN_Cell() (CANCSR |= 0x05)

#endif
/***** (c) 2000 STMicroelectronics ***** END OF FILE _*****/
```

4.3 CAN_CUSTOM.C

```
/***** (c) 1999 STMicroelectronics*****
/***** (c) 1999 STMicroelectronics*****
```

PROJECT :
COMPILER : ST7 COSMIC C v4.2e

MODULE : can_custom.c
VERSION : 1.1.6 build 44

CREATION DATE : 04/99

AUTHOR : Central Europe 8bit Micro Application Group

DESCRIPTION : Customisation functions for CAN driver

MODIFICATIONS :

THE SOFTWARE INCLUDED IN THIS FILE IS FOR GUIDANCE ONLY. ST MICROELECTRONICS
SHALL NOT BE HELD LIABLE FOR ANY DIRECT, INDIRECT OR CONSEQUENTIAL DAMAGES
WITH RESPECT TO ANY CLAIMS ARISING FROM USE OF THIS SOFTWARE.
*****/

#include "lib.h"

#include "can.h"
#include "sci.h"
#include "can_custom.h"

#include "gateway.h"
#include "interface.h"

////////////////////////////////////
//PREPROCESSOR DIRECTIVES//
////////////////////////////////////

////////////////////////////////////
//VARIABLES////////////////////////////////////
////////////////////////////////////



ST7 pCAN PERIPHERAL DRIVER

```
////////////////////////////////////
//Optional functions////////////////////////////////////
////////////////////////////////////

//All those functions are meant to be called by the interrupt routine
//so don't authorize ITs in this file, otherwise it could lead to undefined
behaviour
//of the application

CAN_Buffer* CAN_Request_Buffer(u16 ident_of_message)
{
//The application must supply here a buffer.
}

void CAN_Remote_Reception_Notification(u16 ident_of_remote)
{
//Application behaviour after reception of a remote frame
}

void CAN_Data_Reception_Notification(u16 message_ident)
{
//Application behaviour after reception of a data frame
}

void CAN_Transmission_Notification(void)
{
//Write your code here
}

void CAN_Dominant_Bit_Reception_Notification(void)
{
//Write your code here
}

#ifdef STATUS_CHANGE_NOTIFICATION
void CAN_Bus_Passive_Notification(void)
{
//To implement if defined
}
void CAN_Bus_Active_Notification(void)
{
```

```
//To implement if defined
}
void CAN_Bus_Off_Notification(void)
{
//To implement if defined
}
#endif

#ifdef GENERAL_RECEPTION_ERROR
void CAN_General_Reception_Error_Notification(void)
{
//To implement if defined
}
#endif

#ifdef DEBUG
void CAN_Reception_Status(CAN_Receive_Error status)
{
//To implement if defined
}
void CAN_Overrun_Notification(void)
{
//To implement if defined
}
void CAN_Transmission_Error_Notification(CAN_Transmit_Error status)
{
//To implement if defined
}
#endif
/***** (c) 1999 STMicroelectronics *****/
```

4.4 CAN_CUSTOM.H

```
/***** (c) 1999 STMicroelectronics *****/
```

PROJECT:

COMPILER: ST7 COSMIC C v.4.2e

MODULE: can_custom.h

VERSION: V 1.1.6 build 44

CREATION DATE: 04/00

AUTHOR: Central Europe 8bit Micro Application Group

ST7 pCAN PERIPHERAL DRIVER

DESCRIPTION: CAN customization options

MODIFICATIONS: none

THE SOFTWARE INCLUDED IN THIS FILE IS FOR GUIDANCE ONLY. ST MICROELECTRONICS SHALL NOT BE HELD LIABLE FOR ANY DIRECT, INDIRECT OR CONSEQUENTIAL DAMAGES WITH RESPECT TO ANY CLAIMS ARISING FROM USE OF THIS SOFTWARE.

***** /

```
#ifndef CAN_CUSTOM_H
#define CAN_CUSTOM_H
```

```
//////////
//CUSTOM DEFINES//
//////////
```

```
/
*#####*/
/*          PREPROCESSOR DIRECTIVES          */
/
*#####*/
```

```
//First initialization
/*Timing*/
#define INIT_BRPR 0x00
#define INIT_BTR 0x00
```

```
//Start options
//#define WAKE_UP_PULSE /*Shall the CAN cell emit a dominant pulse by wake-up?*/
#define RUN_ON_START_UP /*Shall the cell run immediately or wait for a bus event?*/
```

```
/*Masks & filters*/
#define INIT_FHR0 0x00
#define INIT_FLR0 0x00
#define INIT_MHR0 0x00
```



```

#define INIT_MLR0  0x00
#define INIT_FHR1  0x00
#define INIT_FLR1  0x00
#define INIT_MHR1  0x00
#define INIT_MLR1  0x00

//SOFTWARE ACCEPTANCE MASKS
//#define FILTERS_ENABLED
//#define INIT_FILTERS { }      /*max identifier : 2048, that's to say 0x0800, max
size of the array :127*/

//ITs COMPILATION OPTIONS
//Have to be disabled if a direct implementation of the IT function
//is meant
//Enabling one of these options implies coding the corresponding function in the
can_custom.c file
//The choice will determine the initialization of the status register

//To monitor status changes
//#define STATUS_CHANGE_NOTIFICATION

//To use other error notifications functions:
//#define DEBUG
//#define GENERAL_RECEPTION_ERROR /*If defined, replaces the status change
interrupts*/
                //Only if debug also defined
                //Does not exclude bus wake-up feature
//#define SIMULTANEOUS_EMISSION_RECEPTION /*Only if debug also defined*/
        //Allows simultaneous reception and reception of a message
        //to check the integrity of the message path
/
*#####*/
/*          VARIABLES          */
/
*#####*/

/*-----CAN SETTINGS-----*/

#endif
/***** (c) 1999 STMicroelectronics *****/ END OF FILE _*****/

```

ST7 pCAN PERIPHERAL DRIVER

4.5 CAN_HR.H

/* ***** (c) 2000 STMicroelectronics ***** */

PROJECT :
 COMPILER : ST7 COSMIC C v.4.2e

MODULE : can.c
 VERSION : V 1.1.6 build 44

CREATION DATE : 04/00

AUTHOR : Central Europe 8bit Micro Application Group

DESCRIPTION : CAN hardware registers

MODIFICATIONS :

 THE SOFTWARE INCLUDED IN THIS FILE IS FOR GUIDANCE ONLY. ST MICROELECTRONICS
 SHALL NOT BE HELD LIABLE FOR ANY DIRECT, INDIRECT OR CONSEQUENTIAL DAMAGES
 WITH RESPECT TO ANY CLAIMS ARISING FROM USE OF THIS SOFTWARE.
 ***** /

```
#ifndef CAN_HR_H
#define CAN_HR_H
```

```
/*-----REGISTER DECLARATION-----*/
```

```
/* Controller Area Network */
```

```
@tiny volatile unsigned char CANISR @0x5a; /* Interrupt Status Register */
@tiny volatile unsigned char CANICR @0x5b; /* Interrupt Control Register */
@tiny volatile unsigned char CANCSR @0x5c; /* Control Status Register */
@tiny volatile unsigned char CANBRPR @0x5d; /* Baud Rate Prescaler Register */
@tiny volatile unsigned char CANBTR @0x5e; /* Bit Timing Register */
@tiny volatile unsigned char CANPSR @0x5f; /* Page Selection Register */
```

```
/* Controller Area Network Paged Registers */
```

```
/* PAGE 0 */
```

```
@tiny volatile unsigned char CANLIDHR @0x60; /* Last Identifier High Register */
@tiny volatile unsigned char CANLIDLR @0x61; /* Last Identifier Low Register */
```



```

@tiny volatile unsigned char CANRes00 @0x62; /* Reserved */
@tiny volatile unsigned char CANRes01 @0x63; /* Reserved */
@tiny volatile unsigned char CANRes02 @0x64; /* Reserved */
@tiny volatile unsigned char CANRes03 @0x65; /* Reserved */
@tiny volatile unsigned char CANRes04 @0x66; /* Reserved */
@tiny volatile unsigned char CANRes05 @0x67; /* Reserved */
@tiny volatile unsigned char CANRes06 @0x68; /* Reserved */
@tiny volatile unsigned char CANRes07 @0x69; /* Reserved */
@tiny volatile unsigned char CANRes08 @0x6a; /* Reserved */
@tiny volatile unsigned char CANRes09 @0x6b; /* Reserved */
@tiny volatile unsigned char CANRes010 @0x6c; /* Reserved */
@tiny volatile unsigned char CANTSTR @0x6d; /* Reserved */
@tiny volatile unsigned char CANTECR @0x6e; /* Transmit Error Counter */
@tiny volatile unsigned char CANRECR @0x6f; /* Receive Error Counter */

/* Pages 1,2,3: Identifiers */
@tiny volatile unsigned char CANIDHR @0x60; /* Identifier High Register */
@tiny volatile unsigned char CANIDLR @0x61; /* Identifier Low Register */

/* Pages 1,2,3: Data */
@tiny volatile unsigned char CANDR[8] @0x62; /* 8 Data Registers */
@tiny volatile unsigned char CANRes1230 @0x6a; /* Reserved */
@tiny volatile unsigned char CANRes1231 @0x6b; /* Reserved */
@tiny volatile unsigned char CANRes1232 @0x6c; /* Reserved */
@tiny volatile unsigned char CANRes1233 @0x6d; /* Reserved */
@tiny volatile unsigned char CANRes1234 @0x6e; /* Reserved */
@tiny volatile unsigned char CANBCSR @0x6f; /* Buffer Control Status Register*/

/* Buffers */
@tiny volatile unsigned char CANFHR0 @0x60; /* Filter 0 High Register */
@tiny volatile unsigned char CANFLR0 @0x61; /* Filter 0 Low Register */
@tiny volatile unsigned char CANMHR0 @0x62; /* Mask 0 High Register */
@tiny volatile unsigned char CANMLR0 @0x63; /* Mask 0 Low Register */
@tiny volatile unsigned char CANFHR1 @0x64; /* Filter 1 High Register */
@tiny volatile unsigned char CANFLR1 @0x65; /* Filter 1 Low Register */
@tiny volatile unsigned char CANMHR1 @0x66; /* Mask 1 High Register */
@tiny volatile unsigned char CANMLR1 @0x67; /* Mask 1 Low Register */

/*-----REGISTER BITS DEFINITION-----*/

#define RXIF3 7 /* Interrupt Status Register */
#define RXIF2 6
#define RXIF1 5

```

ST7 pCAN PERIPHERAL DRIVER

```
#define TXIF      4
#define SCIF      3
#define ORIF      2
#define TEIF      1
#define EPND      0

#define ESCI      6          /* Interrupt Control Register */
#define RXIE      5
#define TXIE      4
#define SCIE      3
#define ORIE      2
#define TEIE      1
#define ETX       0

#define BOFF      6          /* Control Status Register */
#define EPSV      5
#define SRTE      4
#define NRTX      3
#define FSYN      2
#define WKPS      1
#define RUN       0

#define RJW1      7          /* Baud Rate Prescaler Register */
#define RJW0      6
#define BRP5      5
#define BRP4      4
#define BRP3      3
#define BRP2      2
#define BRP1      1
#define BRP0      0

#define BS22      6          /* Bit Timing Register */
#define BS21      5
#define BS20      4
#define BS13      3
#define BS12      2
#define BS11      1
#define BS10      0

#define PAGE0     0          /* Page Selection Register */
#define PAGE1     1
#define PAGE2     2
#define PAGE3     3
#define PAGE4     4
```

ST7 pCAN PERIPHERAL DRIVER

```
#define RTR      4
#define MSK_DLC  0x0F      /* Identifier Low Register */

#define ACC      3      /* Buffer Control Status Register */
#define RDY      2      /* Buffer Control Status Register */
#define BUSY     1
#define LOCK     0
/*-----*/

#endif

/***** (c) 2000 STMicroelectronics *****/
```

ST7 pCAN PERIPHERAL DRIVER

"THE PRESENT NOTE WHICH IS FOR GUIDANCE ONLY AIMS AT PROVIDING CUSTOMERS WITH INFORMATION REGARDING THEIR PRODUCTS IN ORDER FOR THEM TO SAVE TIME. AS A RESULT, STMICROELECTRONICS SHALL NOT BE HELD LIABLE FOR ANY DIRECT, INDIRECT OR CONSEQUENTIAL DAMAGES WITH RESPECT TO ANY CLAIMS ARISING FROM THE CONTENT OF SUCH A NOTE AND/OR THE USE MADE BY CUSTOMERS OF THE INFORMATION CONTAINED HEREIN IN CONNEXION WITH THEIR PRODUCTS."

Information furnished is believed to be accurate and reliable. However, STMicroelectronics assumes no responsibility for the consequences of use of such information nor for any infringement of patents or other rights of third parties which may result from its use. No license is granted by implication or otherwise under any patent or patent rights of STMicroelectronics. Specifications mentioned in this publication are subject to change without notice. This publication supersedes and replaces all information previously supplied. STMicroelectronics products are not authorized for use as critical components in life support devices or systems without the express written approval of STMicroelectronics.

The ST logo is a registered trademark of STMicroelectronics

©2001 STMicroelectronics - All Rights Reserved.

Purchase of I²C Components by STMicroelectronics conveys a license under the Philips I²C Patent. Rights to use these components in an I²C system is granted provided that the system conforms to the I²C Standard Specification as defined by Philips.

STMicroelectronics Group of Companies

Australia - Brazil - China - Finland - France - Germany - Hong Kong - India - Italy - Japan - Malaysia - Malta - Morocco - Singapore - Spain
Sweden - Switzerland - United Kingdom - U.S.A.

<http://www.st.com>



LittleDiode supplies new, hard to find or obsolete electronic components and semiconductors all over the world.

With over two million different components listed you are sure to find the part you need.

Feel free to visit us today at our online store:

LittleDiode.com

Looking forward to providing you with the best possible service.