

AN1084, AN1084S

Quadruple J-FET Input Operational Amplifiers

Overview

The AN1084 and the AN1084S are quadruple operational amplifiers with input stages consisting of P-ch J-FET adopting the ion implantation process, realizing high speed response, high input impedance and low input bias current. Therefore, they can be applied widely to general control equipment and medical equipment such as integrators, sample & hold circuits and high input impedance buffers.

Features

- High slew rate : $SR = 11V/\mu s$ typ.
- Low input bias current : $I_{bias} = 30pA$ typ.
- Low offset current : $I_{IO} = 5pA$ typ.
- High impedance : $10^{12}\Omega$
- High voltage gain : $G_V = 106dB$ typ.
- Wide range of supply voltage : $\pm 5V$ to $\pm 18V$
- Phase compensation circuit built-in

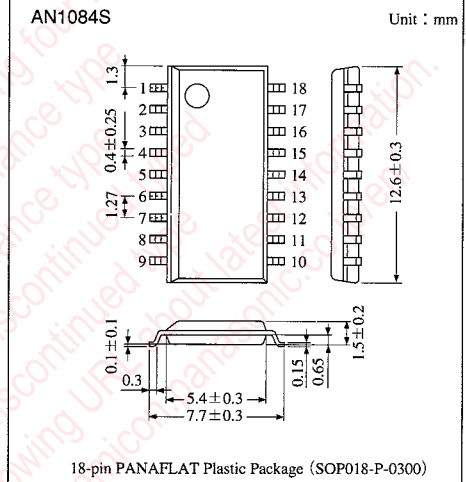
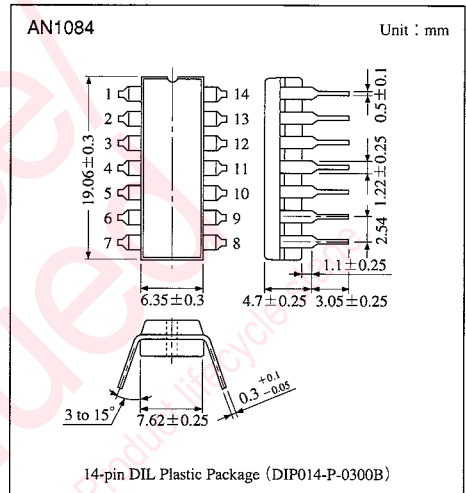

Operational Amplifiers

Block Diagrams

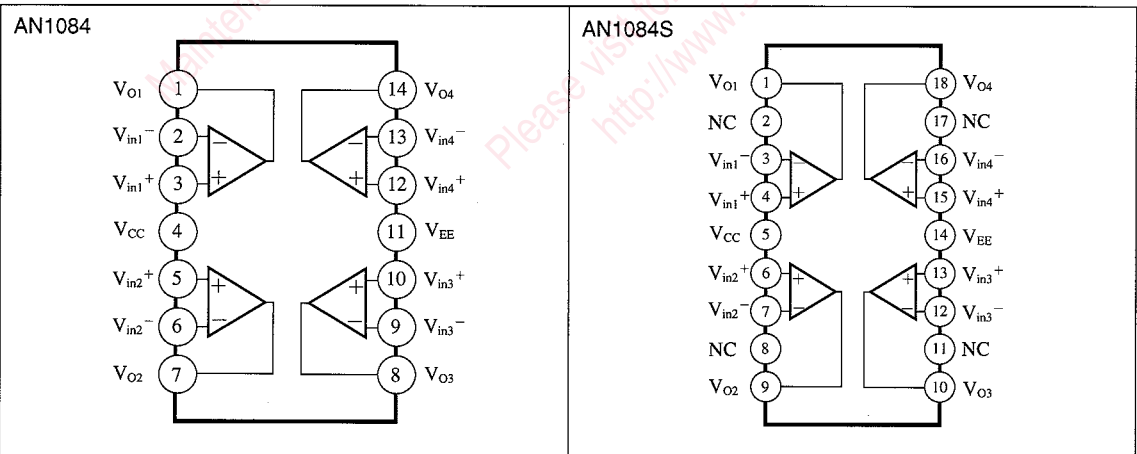

Pin Descriptions

<AN1084>

Pin No.	Pin name	Pin No.	Pin name
1	Ch.1 output	8	Ch.3 output
2	Ch.1 inverting input	9	Ch.3 inverting input
3	Ch.1 non inverting input	10	Ch.3 non inverting input
4	V _{CC}	11	V _{EE}
5	Ch.2 non inverting input	12	Ch.4 non inverting input
6	Ch.2 inverting input	13	Ch.4 inverting input
7	Ch.2 output	14	Ch.4 output

<AN1084S>

Pin No.	Pin name	Pin No.	Pin name
1	Ch.1 output	10	Ch.3 output
2	NC	11	NC
3	Ch.1 inverting input	12	Ch.3 inverting input
4	Ch.1 non inverting input	13	Ch.3 non inverting input
5	V _{CC}	14	V _{EE}
6	Ch.2 non inverting input	15	Ch.4 non inverting input
7	Ch.2 inverting input	16	Ch.4 inverting input
8	NC	17	NC
9	Ch.2 output	18	Ch.4 output

Absolute Maximum Ratings (T_a = 25°C)

Parameter		Symbol	Rating	Unit
Voltage	Supply voltage	V _{CC}	±18	V
	Differential input voltage	V _{ID}	±30	V
	Common-mode input voltage	V _{ICM}	±15	V
Power dissipation	AN1084	P _D	570	mW
	AN1084S		420	
Operating ambient temperature		T _{opr}	-20 to +75	°C
Storage temperature	AN1084	T _{stg}	-55 to +150	°C
	AN1084S		-55 to +125	

Electrical Characteristics ($V_{CC}=15V, V_{EE}=-15V, T_a=25^\circ C$)

Parameter	Symbol	Condition	min	typ	max	Unit
Input offset voltage	$V_{I(\text{offset})}$	$R_S \cong 50\Omega$	—	2	10	mV
Input offset current	I_{IO}		—	5	200	pA
Input bias current	I_{bias}		—	30	400	pA
Voltage gain	G_V	$R_L \cong 2k\Omega, V_O = \pm 10V$	88	106	—	dB
Maximum output voltage	$V_{O(\text{max})}$	$R_L \geq 10k\Omega$	± 12	± 14	—	V
Maximum output voltage	$V_{O(\text{max})}$	$R_L \geq 2k\Omega$	± 10	± 12.5	—	V
Common-mode input voltage range	V_{CM}		± 10	—	—	V
Common-mode rejection ratio	CMR		70	76	—	dB
Supply voltage rejection ratio	SVR		70	76	—	dB
Power consumption	P_C	$R_L = \infty$	—	250	336	mW
Slew rate	SR	$R_L \geq 2k\Omega$	—	11	—	V/ μs
Zero-cross frequency	$f(T)$	$A_V = 1$	—	3	—	MHz
Equivalent input noise voltage	V_{ni}	$R_S = 100\Omega, B = 10\text{Hz to } 30\text{kHz}$	—	4	—	μV_{rms}

Characteristics Curve

Operational Amplifiers

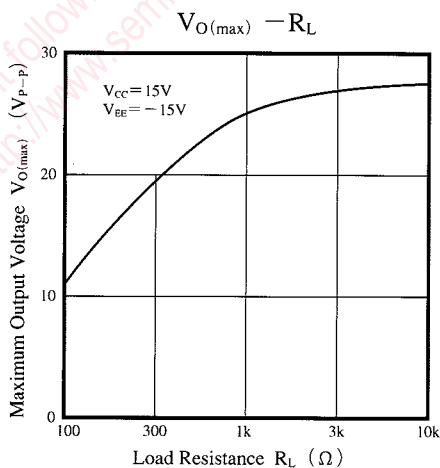
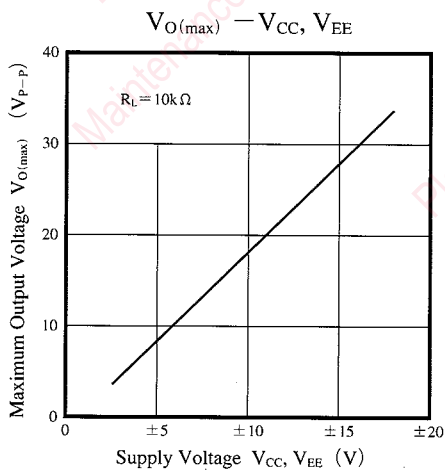
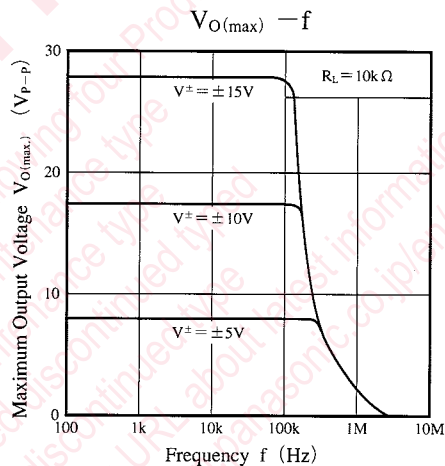
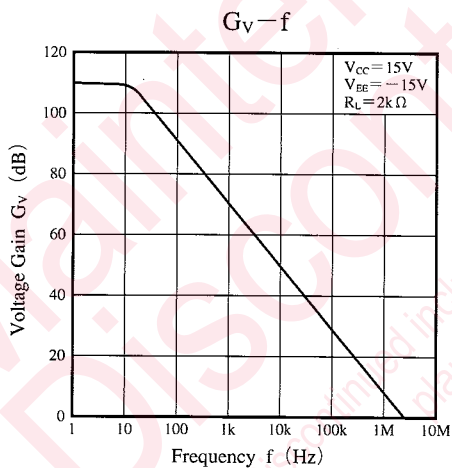

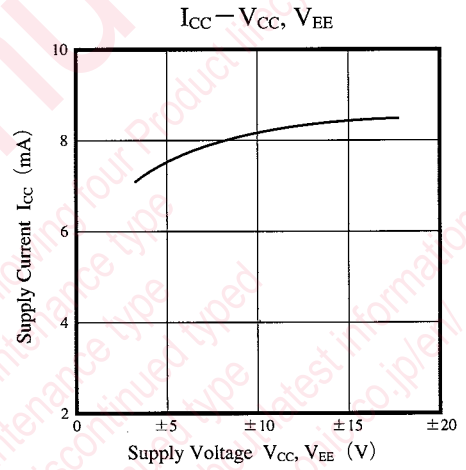
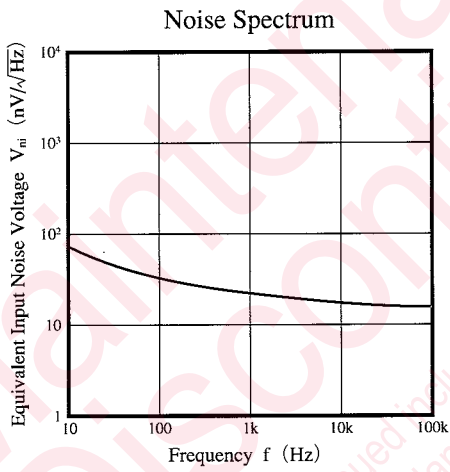
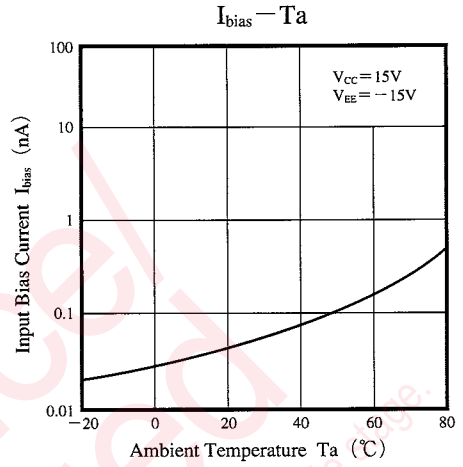
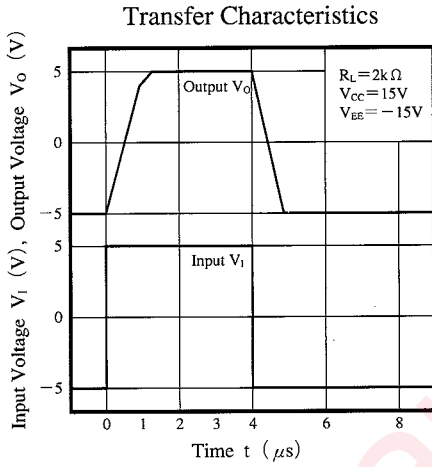

Request for your special attention and precautions in using the technical information and semiconductors described in this book

- (1) If any of the products or technical information described in this book is to be exported or provided to non-residents, the laws and regulations of the exporting country, especially, those with regard to security export control, must be observed.
- (2) The technical information described in this book is intended only to show the main characteristics and application circuit examples of the products. No license is granted in and to any intellectual property right or other right owned by Panasonic Corporation or any other company. Therefore, no responsibility is assumed by our company as to the infringement upon any such right owned by any other company which may arise as a result of the use of technical information described in this book.
- (3) The products described in this book are intended to be used for standard applications or general electronic equipment (such as office equipment, communications equipment, measuring instruments and household appliances).
Consult our sales staff in advance for information on the following applications:
 - Special applications (such as for airplanes, aerospace, automobiles, traffic control equipment, combustion equipment, life support systems and safety devices) in which exceptional quality and reliability are required, or if the failure or malfunction of the products may directly jeopardize life or harm the human body.
 - Any applications other than the standard applications intended.
- (4) The products and product specifications described in this book are subject to change without notice for modification and/or improvement. At the final stage of your design, purchasing, or use of the products, therefore, ask for the most up-to-date Product Standards in advance to make sure that the latest specifications satisfy your requirements.
- (5) When designing your equipment, comply with the range of absolute maximum rating and the guaranteed operating conditions (operating power supply voltage and operating environment etc.). Especially, please be careful not to exceed the range of absolute maximum rating on the transient state, such as power-on, power-off and mode-switching. Otherwise, we will not be liable for any defect which may arise later in your equipment.
 - Even when the products are used within the guaranteed values, take into the consideration of incidence of break down and failure mode, possible to occur to semiconductor products. Measures on the systems such as redundant design, arresting the spread of fire or preventing glitch are recommended in order to prevent physical injury, fire, social damages, for example, by using the products.
- (6) Comply with the instructions for use in order to prevent breakdown and characteristics change due to external factors (ESD, EOS, thermal stress and mechanical stress) at the time of handling, mounting or at customer's process. When using products for which damp-proof packing is required, satisfy the conditions, such as shelf life and the elapsed time since first opening the packages.
- (7) This book may be not reprinted or reproduced whether wholly or partially, without the prior written permission of our company.



LittleDiode supplies new, hard to find or obsolete electronic components and semiconductors all over the world.

With over two million different components listed you are sure to find the part you need.

Feel free to visit us today at our online store:

LittleDiode.com

Looking forward to providing you with the best possible service.