

**AUXILIARY POWER SUPPLY USING VIPer20****E. CHOU**  
STMicroelectronics**1 Introduction**

The present board prototype is a 120 to 375 VDC input off-line single switch Flyback, working at 100 kHz. It is based on a new off-line smart switcher : the VIPer20.

The VIPer20 is a current mode PWM with a 620V/16Ω power switch, able to withstand an avalanche current during normal operation. The start up of the circuit is done with an internal high voltage current source, which is switched off during steady state. It also includes a regulation function designed to minimise the pin count, while maintaining design flexibility.

Such a device can be easily used in any off line Flyback SMPS, with a 20W minimum power capability for a single input voltage range or 10W with a wide input range. This stand-alone off-line Smart Switcher concept provides a cost effective solution for SMPS of many applications. The benefits for the customer are a simpler design phase and a reduced overall components count due to the optimisation of the product configuration.

**2 Electrical definition**

The complete schematics of the power supply is given in page 2. Figure 1 is table of key electrical parameters.

**Figure 1:** Table of electrical parameters

PARAMETER	SPECIFICATION
Input Voltage Range	120 ~ 375 VDC
Output Voltage	5V +/- 5%
Output power (continuous)	6W
Load Regulation (0.1 ~ 1A)	250 mV p-p Max.
Efficiency	>70%
Output Ripple Voltage	100mV Max.
Vout in OVP	6.9V Max.

**Component List**

Component	Reference	Value	Unit
Resistors	R9	10	Ω
	R8	1.2	kΩ
	R7	120	Ω
	R6	4.7	kΩ
	R5	4.7	kΩ
	R4	47	Ω
	R3	8.2	kΩ
	R2	5.1	kΩ
	R1	5.1	kΩ

# APPLICATION NOTE

## Component List (continued)

Component	Reference	Value	Unit
Capacitors	C8	100 (400V)	nF
	C7	22	nF
	C6	470	nF
	C5	2200	μF
	C4	1000	μF
	C3	47	μF
	C2	0.47	μF
	C1	3.9	nF
Diodes	ZD	P6KE200*	
	ZD1	4.3V Zener	
	D1	BYT11-600*	
	D2	1N4148	
	D3	STPS140	
IC	IC1	VIPer20	
	IC2	TL-431	
Optocoupler	PC	PC817A	
Transformer	T1	1400	μH
Inductance	L1	6.8	μH

\* These devices are optional. It depends on the voltage spike on drain pin of VIPer. If transformer has small leakage inductance in small power application, such snubber circuit is unnecessary.

## 3 Schematic

Figure 2: Electrical Schematic

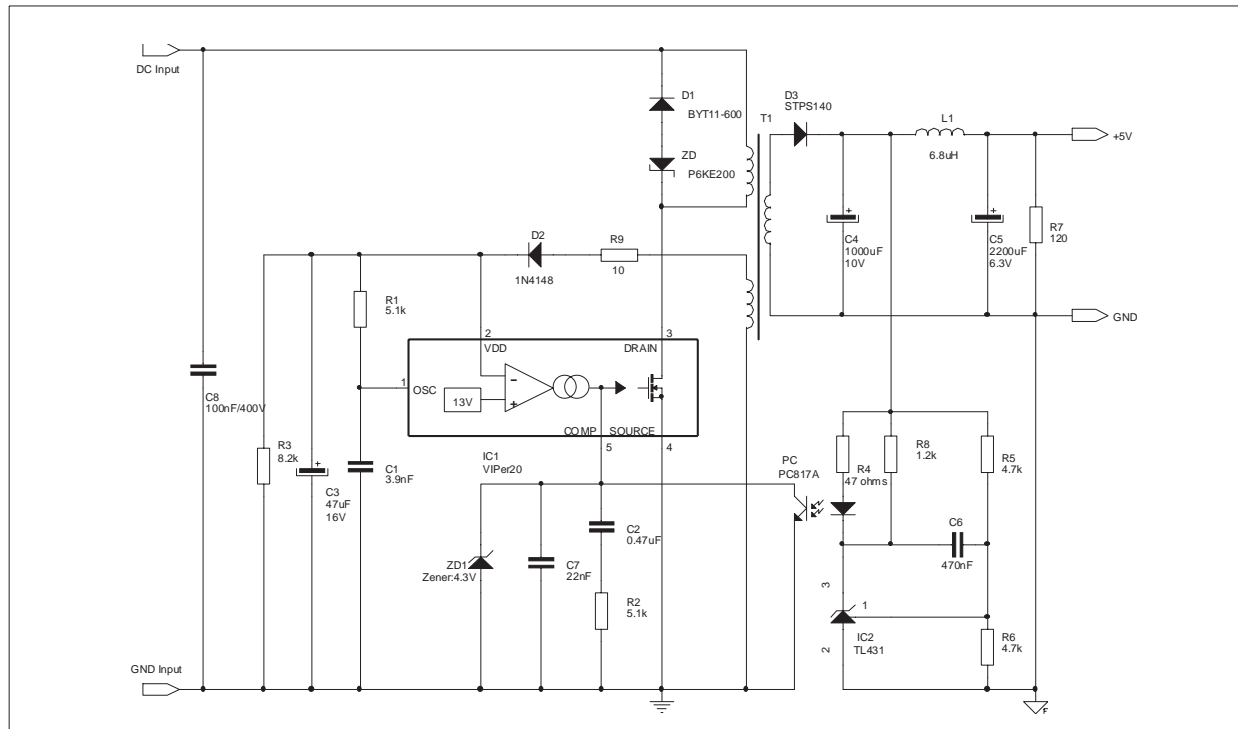

## 4 Electrical Specification of Transformer

Primary turns N1--2x 62T (TWO primary split windings)

Secondary winding N2-- 7T (FOR 5V o\p)

Auxiliary supply N3-- 15T.

Primary Inductance required is 1.4mH FOR 6W 0\p POWER at 100KHz.

Primary leakage inductance required is 15uH max. at 100KHz.

CORE# - PC30 EE16-Z (TDK)

BOBBIN# - BE16-118CPH (TDK)

**Figure 3:** Pin Allocation of Transformer

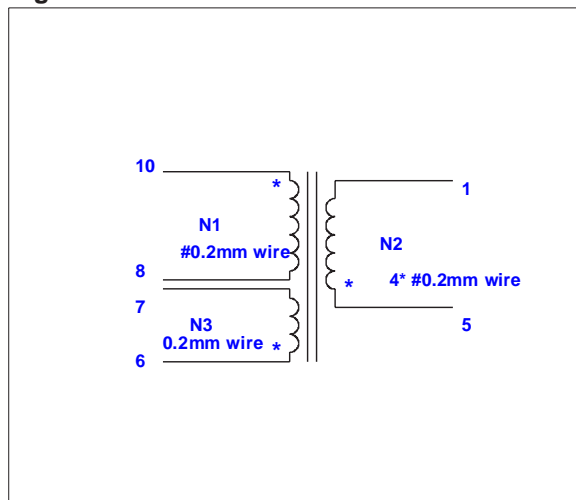

**Figure 4:** Transformer Construction

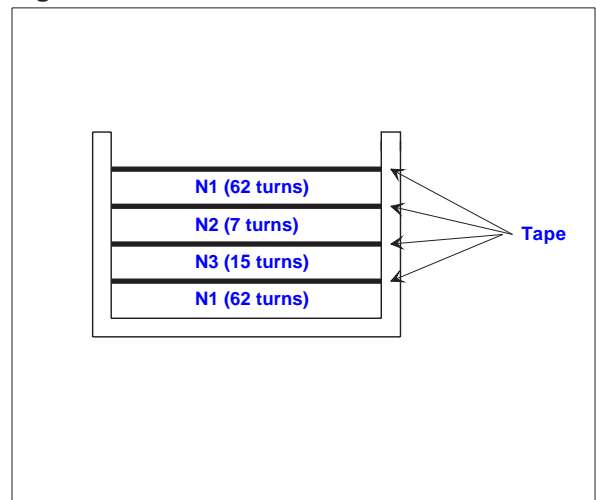

## 5 Layout Recommendation

Some simple rules insure a correct running of switching power supplies. They may be classified into two categories:

- To minimise power loops: the way the switched power current must be carefully analysed and the corresponding paths must present the smallest inner loop area as possible. This avoids radiated EMC noises, conducted EMC noises by magnetic coupling, and provides a better efficiency by eliminating parasitic inductances, especially on secondary side.
- To use different tracks for low level signals and power ones. The interferences due to a mixing of signal and power may result in instabilities and/or anomalous behaviour of the device in case of violent power surge (Input overvoltages, output short circuits...). In the case of VIPer, these rules apply as shown in figure 2. The loops DC input capacitance-T1-IC1, C3-D2-T1, C4-D3-T1 must be minimised. The signal components C1, PC-2 and R2 are using a dedicated track to be connected directly to the source of the device.



## Appendix A: Simulation Result with VIPerxxx Software Ver. 1.01

PROJECT INPUT	Value	Unit
Min. AC input voltage	85	V
Max. AC input voltage	265	V
Line frequency	50	Hz
Switching frequency	100	kHz
Output voltage	5	V
Nominal output power	6	W
Min. output power	0.1	W
Efficiency	0.8	
Input ripple	10	V
First cell output ripple	0.5	V
Second cell output ripple	0.1	V
Ro*Co	65	ohm* $\mu$ F
Soft startup	5	msec
Optocoupler Gain	0.7	
Primary inductance	1400	$\mu$ H
TurnsRatio	17.715	Np/Ns
Primary leak inductance	42	$\mu$ H
Secondary turns	7	
Auxiliary turns	17	
Regulation type	Secondary regulation	
Device type	VIPer50-Sec..Reg.-Zener	

PROJECT OUTPUT	Value	Unit
Operation mode	Discontinuous	
Min. DC input voltage	111.6	V
Max. DC input voltage	375	V
Computed inut ripple	8.58	V
Max. duty circle	0.41	
Primary peak curren	:0.33	A
Primary RMS current	0.12	A
Secondary peak current	4.07	A
Secondary RMS current	1.8	A
Max. drain voltage	585	V
Standard input capacitor	82	$\mu$ F
Oscillator R2 value	5.03	kohm
Oscillator C4 value	3.9	nF
Standard C7 capacitor	1000	$\mu$ F
Standard C8 capacitor	1000	$\mu$ F
Reflected output voltage	106.29	V
Zener clamp voltage	210	V

Information furnished is believed to be accurate and reliable. However, STMicroelectronics assumes no responsibility for the consequences of use of such information nor for any infringement of patents or other rights of third parties which may result from its use. No license is granted by implication or otherwise under any patent or patent rights of STMicroelectronics. Specifications mentioned in this publication are subject to change without notice. This publication supersedes and replaces all information previously supplied. STMicroelectronics products are not authorized for use as critical components in life support devices or systems without express written approval of STMicroelectronics.

The ST logo is a registered trademark of STMicroelectronics

© 1998 STMicroelectronics - Printed in ITALY- All Rights Reserved.

STMicroelectronics GROUP OF COMPANIES

Australia - Brazil - Canada - China - France - Germany - Italy - Japan - Korea - Malaysia - Malta - Mexico - Morocco -  
The Netherlands - Singapore - Spain - Sweden - Switzerland - Taiwan - Thailand - United Kingdom - U.S.A.



LittleDiode supplies new, hard to find or obsolete electronic components and semiconductors all over the world.

With over two million different components listed you are sure to find the part you need.

Feel free to visit us today at our online store:

[LittleDiode.com](http://LittleDiode.com)

Looking forward to providing you with the best possible service.