

Designing with L4978, 2A High Efficiency DC-DC Converter

by N. Tricomi and D. Arrigo

INTRODUCTION

The L4978 is a 2A monolithic dc-dc converter, step-down, operating at fixed frequency continuous mode. It is realised in BCD60 II technology, and it's available in two plastic packages, MINIDIP and SO16L.

One direct fixed output voltage at $3.3V \pm 1\%$ is available, adjustable for higher output voltage values, till 40V, by an external voltage divider.

The operating input supply voltage ranges from 8V to 55V, while the absolute value, with no load, is 60V. New internal design solutions and superior technology performance allow to generate a device with improved efficiency in all the operating conditions and with reduced EMI due to an innovative internal driving circuit, and reduced external component counts.

While internal limiting current and thermal shutdown are today considered standard protection functions, mandatory for a safe load supply, oscillator with voltage feedforward improves line regulation and overall control loop.

Soft-start avoids output overvoltages at turn-on, while, shorting this pin to ground, the device is completely disabled, going into zero consumption state.

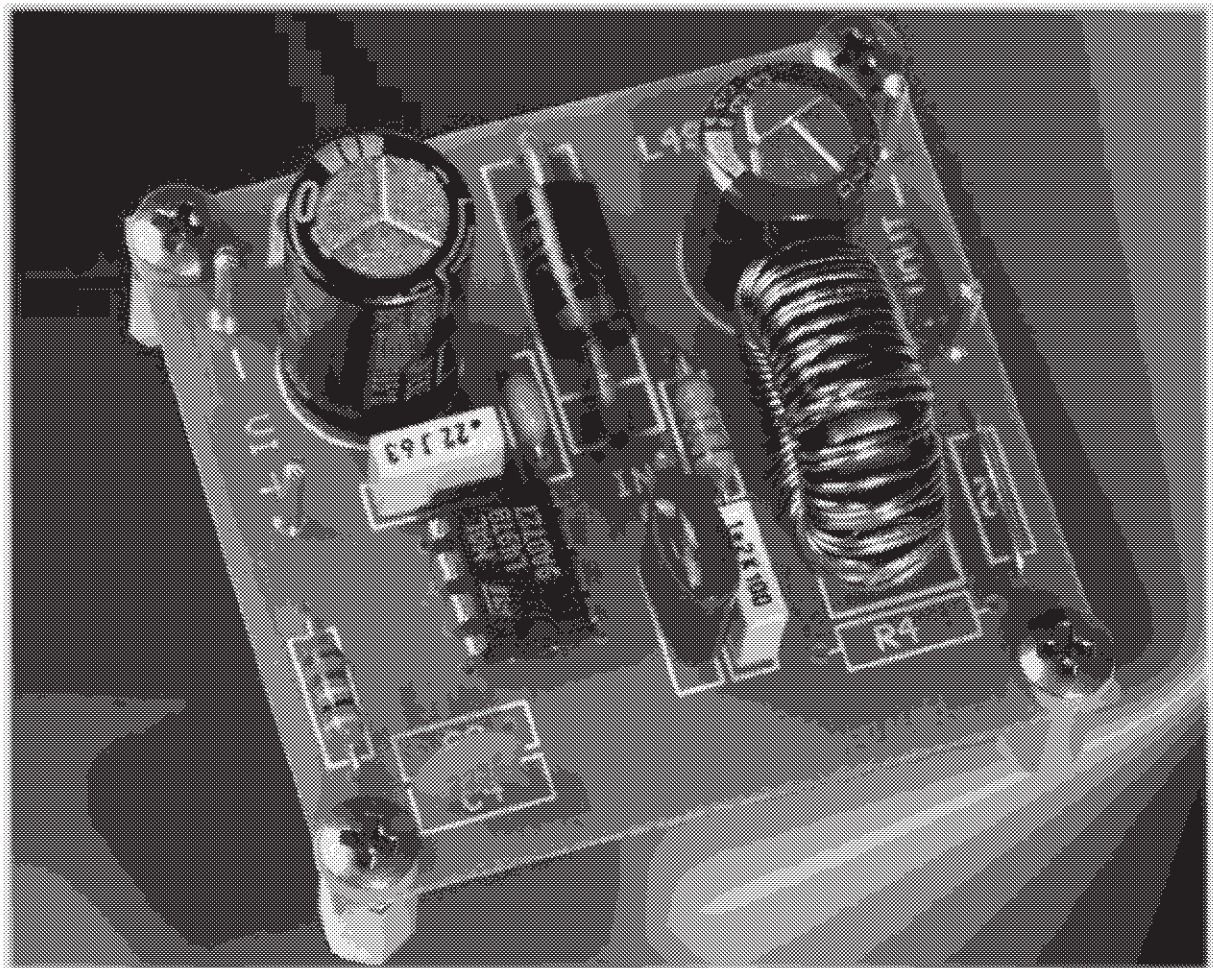

AN1061 APPLICATION NOTE

DEVICE DESCRIPTION

For a better understanding of the device and its working principles, a short description of the main building blocks is given here below, with packaging options and complete block diagram.

Figure 1 shows the two packaging options, with the pin function assignments.

Figure 1. Pins connection.

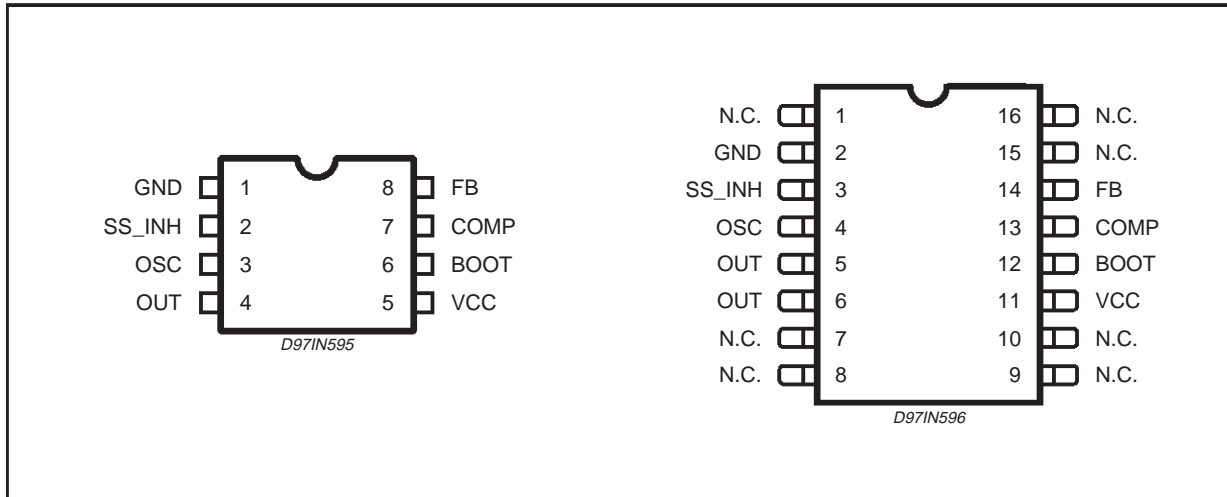
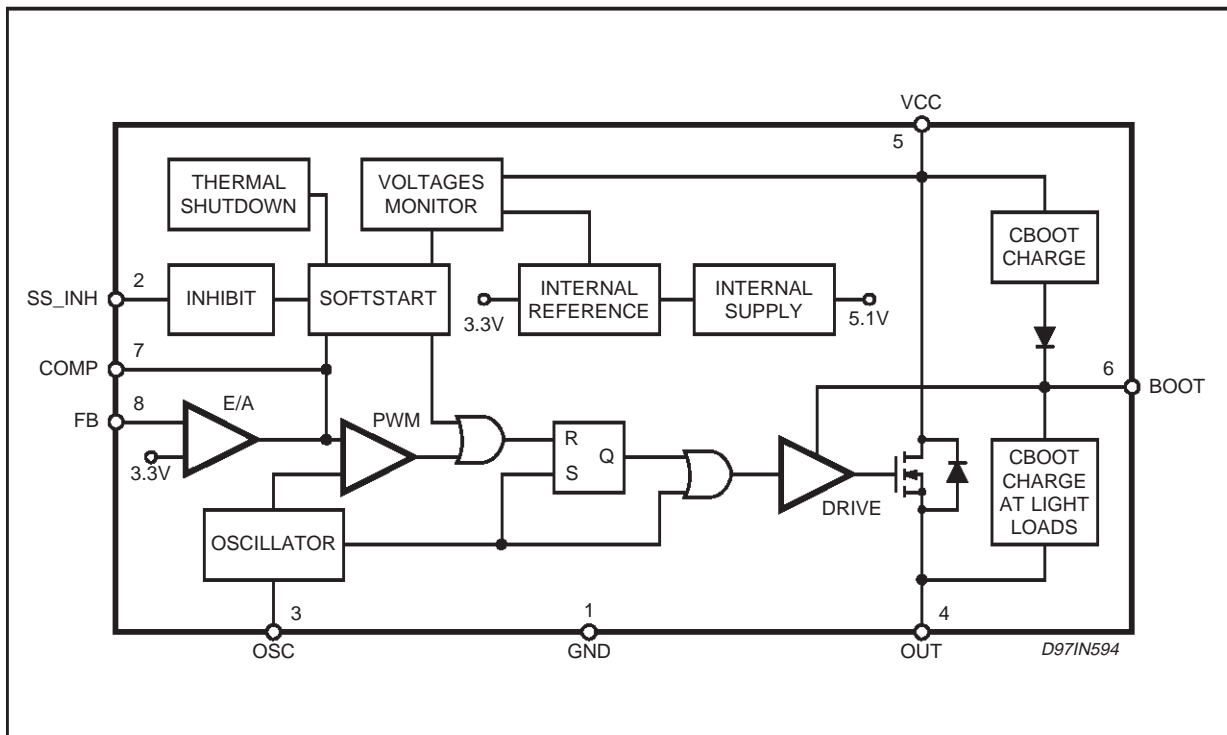

Figure 2. Block diagram.



Power supply & Voltage reference

The device is provided with an internal stabilised power supply (of about 12V typ.) that powers the analog and digital control blocks and the bootstrap section.

From this preregulator, a 3.3V reference voltage $\pm 2\%$, is internally available.

Oscillator and voltage feedforward.

Just one pin is necessary to implement the oscillator function, with inherent voltage feedforward.

Figure 3. Oscillator internal circuit.

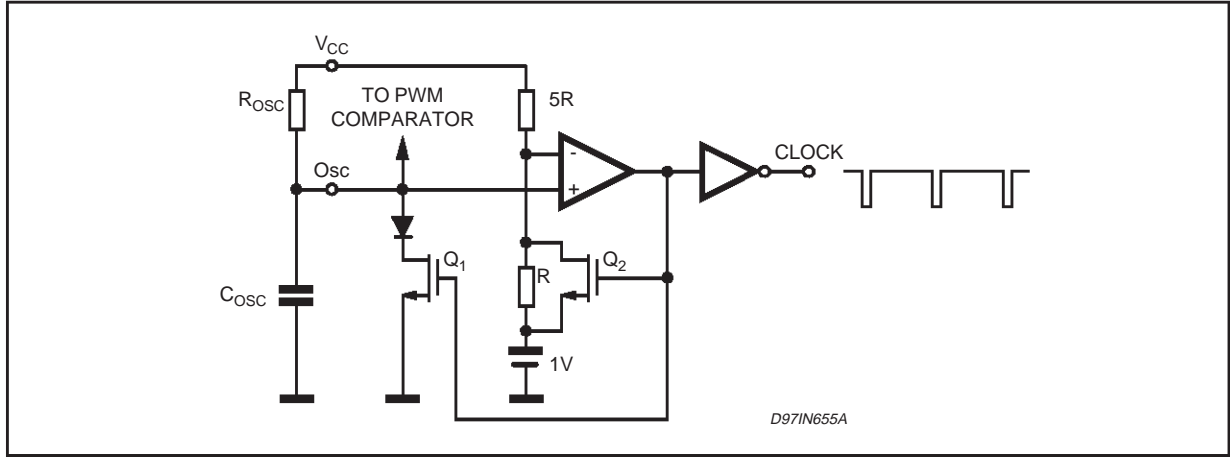

A resistor R_{osc} and a capacitor C_{osc} connected as shown in Figure 3, allow the setting of the desired switching frequency in agreement with the below formula:

$$F_{sw} = \frac{1}{R_{osc} \cdot C_{osc} \ln\left(\frac{6}{5}\right) + 100 \cdot C_{osc}}$$

Where F_{sw} is in kHz, R_{osc} in $K\Omega$ and C_{osc} in nF.

The oscillator capacitor, C_{osc} , is discharged by an internal mos transistor with 100Ω of R_{dson} (Q1) and during this period the internal threshold is set at 1V by a second mos, Q2. When the oscillator voltage capacitor reaches the 1V threshold, the output comparator turns off the mos Q1 and turns on the mos Q2, restarting the C_{osc} charge.

Figure 4. Switching frequency vs. R_{osc} and C_{osc} .

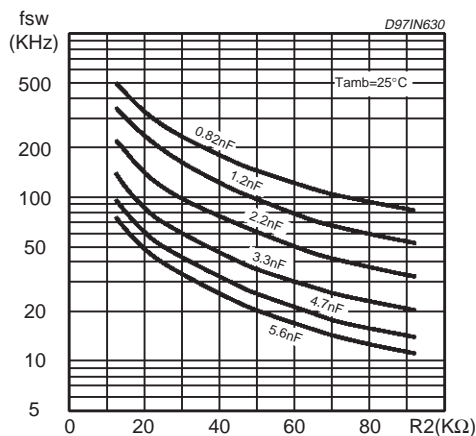

The oscillator block, shown in figure 4, generates a sawtooth wave signal that sets the switching frequency of the system.

This signal, compared with the output of the error amplifier, generates the PWM signal that will modulate the conduction time of the power output stage.

The way the oscillator has been integrated, does not require additional external components to benefit of the voltage feedforward function.

The oscillator peak-to-valley voltage is proportional to the supply voltage, and the voltage feedforward is operative from 8V to 55V of input supply.

$$\Delta V_{osc} = \frac{V_{cc} - 1}{6}$$

Also the $\Delta V/\Delta t$ of the sawtooth is directly proportional to the supply voltage. As V_{cc} increases, the T_{on} time of the power transistor decreases in such a way to provide to

the chocke, and finally also the load, the product Voltxsec constant.

Figure 5 shows how the duty cycle varies as a result of the change on the $\Delta V/\Delta t$ of the sawtooth with the V_{cc} .

Figure 5. Voltage Feedforward Function.

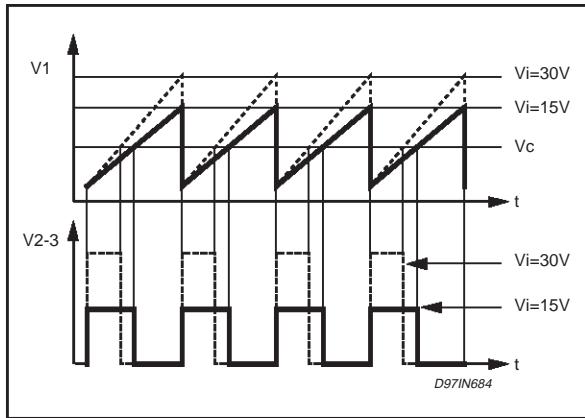

The output of the error amplifier doesn't change in order to maintain the output voltage constant and in regulation.

With this function on board, the output response time is greatly reduced in presence of an abrupt change on the supply voltage, and the output ripple voltage at the mains frequency is greatly reduced too.

In fact, the slope of the ramp is modulated by the input ripple voltage, generally present in the order of some tens of Volt, for both off-line and dc-dc converters using mains transformers.

The charge and discharge time are approximable to:

$$T_{ch} = R_{osc} \cdot C_{osc} \cdot \ln\left(\frac{6}{5}\right)$$

$$T_{dis} = 100 \cdot C_{osc}$$

Figure 6. Maximum Duty Cycle vs R_{osc} and C_{osc} as parameter

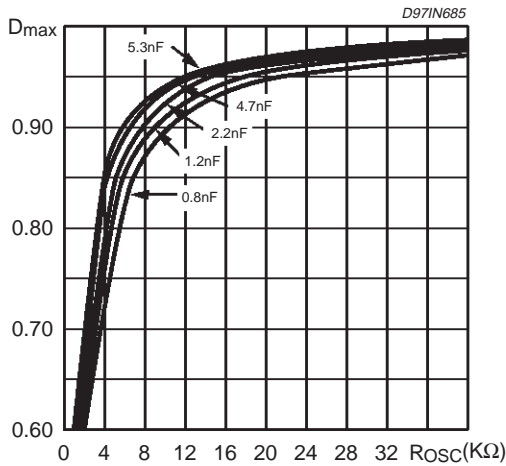

The maximum duty cycle is a function of T_{ch}, T_{dis} and an internal delay and is expressed by the equation:

$$D_{max} = \frac{R_{osc} \cdot C_{osc} \cdot \ln\left(\frac{6}{5}\right) - 80 \cdot 10^9}{R_{osc} \cdot C_{osc} \cdot \ln\left(\frac{6}{5}\right) + 100 \cdot C_{osc}}$$

and is represented in figure 6.

Current Protection

The L4978 has two current limit levels, pulse by pulse and hiccup modes.

Increasing the output current till the pulse by pulse limiting current threshold (I_{th1} typ. value of 3A) the controller reduces the on-time till the value of T_B = 300ns that is a blanking time in which the current limit protection does not trigger. This minimum time is necessary to avoid undesirable intervention of the protection due to the spike current generated during the recovery time of the freewheeling diode.

In this condition, because of this fixed blanking time, the output current is given by:

$$I_{max} = \frac{[V_{CC} \cdot T_B \cdot F_{sw} - V_f \cdot (1 - T_B \cdot F_{sw})]}{[R_o + (R_D + R_L) (1 - T_B \cdot F_{sw}) + (R_{dson} + R_L) T_B \cdot F_{sw}]}$$

Where R_o is the load resistance, V_f is the diode forward voltage. R_D and R_L are the series resistance of, respectively, the freewheeling diode and the choke.

Typical output characteristics are represented in figure 7.1 and 7.2.

In fig 7.1, the pulse by pulse protection is sufficient to limit the current.

In fig 7.2 the pulse by pulse protection is no more effective to limit the current due to the minimum T_{on} fixed by the blanking time T_B, and the hiccup protection intervenes because the output peak current reaches the relative threshold.

At the pulse by pulse intervention (point A) the output voltage drops because of the T_{on} reduction, and the current is almost constant. Going versus the short circuit condition, the current is only limited by the series resistances R_D and R_L (see relation above) and could reach the hiccup threshold (point B), set 20% higher than the pulse by pulse. Once the hiccup limiting current is operating, in output short circuit

condition, the delivered average output current decreases dramatically at very low values (point C).

Figure 7.1. Output Characteristic

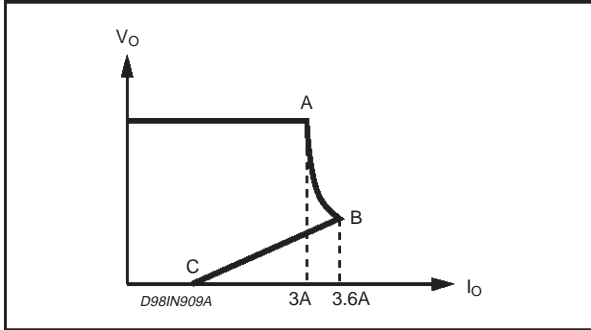

Figure 7.2. Output Characteristic

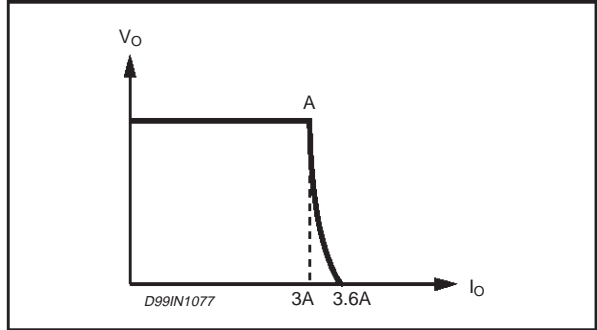

Figure 8. Current Limit internal schematic circuit.

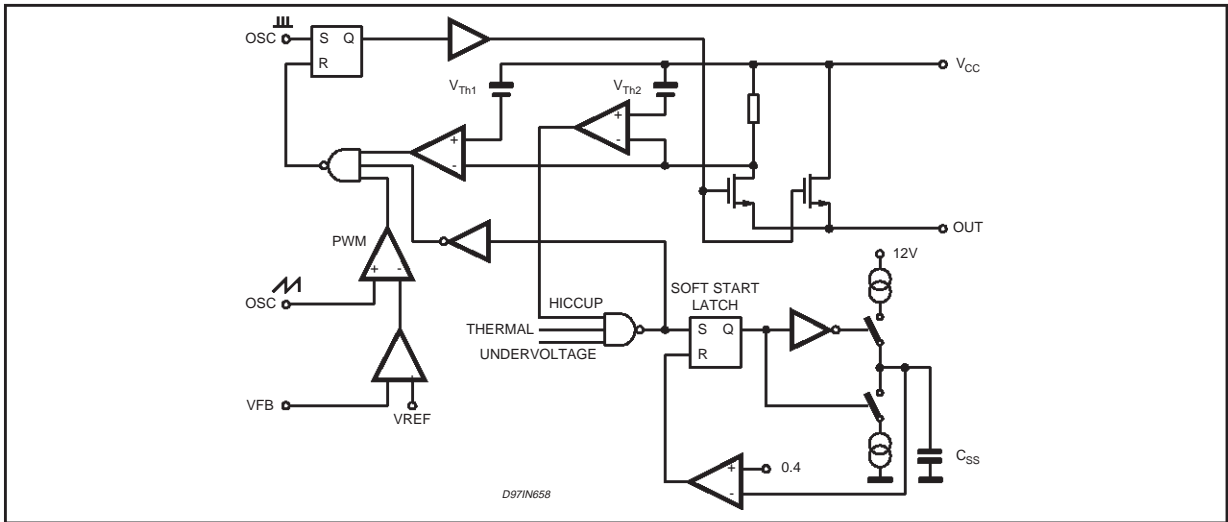

Figure 8 shows the internal current limiting circuitry. V_{th1} is the pulse by pulse while V_{th2} is the hiccup threshold.

The sense resistor is in series with a small mos realised as a partition of the main DMOS.

The V_{th2} comparator (20% higher than V_{th1}) sets the soft start latch, initialising the discharge of the soft start capacitor with a constant current (about $22\mu A$). Reaching about 0.4V, the valley comparator resets the soft start latch, restarting a new recharge cycle.

Figure 9 Shows the typical waveforms of the current in the output inductor and the soft start voltage (pin 2).

During the recharging of the soft start capacitor, the T_{on} increases gradually and, if the short circuit is still present, when $T_{on} > T_B$ and the output peak current reaches the threshold, the hiccup protection intervenes again. So, the value of the soft start capacitor must not be too high (in this case the T_{on} increases slowly thus taking much time to reach the T_B value) to avoid that during the soft start slope the current exceeds the limit before the protection activation.

The following diagrams of Figure 10a and Figure 10b show the maximum allowed soft-start capacitor as a function of the input voltage, inductor value and switching frequency. A minimum value of the soft start capacitance is necessary to guarantee, in short circuit condition, the functionality of the limiting current circuitry. In fact, with a capacitor too small, the frequency of the current peaks (see figure 9) is high and the mean current value in short circuit increases.

Figure 9. Output current and soft-start voltage

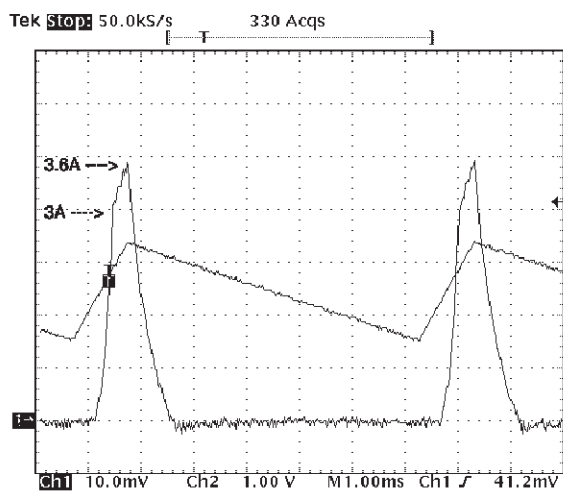

Figure 10a. Maximum Soft Start Capacitance with $f_{sw} = 100\text{kHz}$

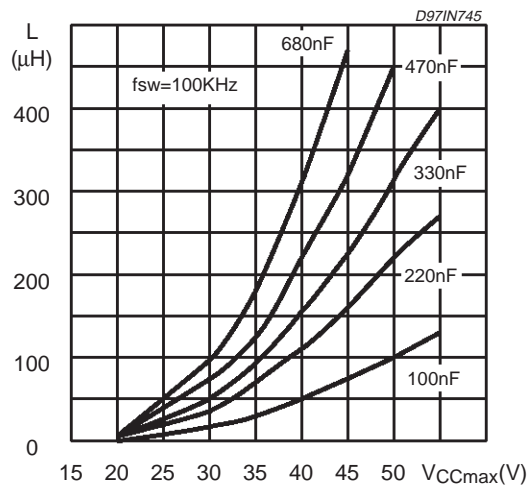
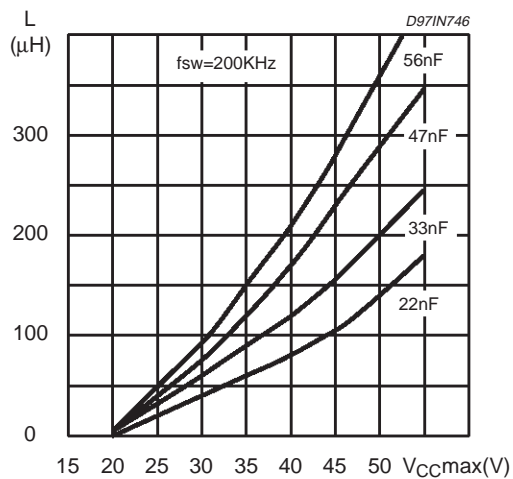

Figure 10b. Maximum Soft Start Capacitance with $f_{sw} = 200\text{kHz}$



Soft Start and Inhibit functions.

The soft start and the inhibit functions are realised using one pin only, pin2. Soft-start is requested to initialise all internal functions with a correct start-up of the system without overstressing the power stage, avoiding the intervention of the current protection, and having an output voltage rising smoothly without output overshoots.

At V_{cc} Turn-on or having had an intervention of inhibit function, an initial $5\mu\text{A}$ internal current generator starts to charge the soft-start capacitor, from 0V to about 1.8V . From this hysteretic threshold, a $40\mu\text{A}$ current generator is activated, putting in off state the previous generator.

At this point, the output PWM starts, initiating the rising phase of the output voltage.

The soft-start capacitor is quickly discharged in case of:

- Thermal protection intervention
- Hiccup limiting current condition
- Supply voltage lower than UVLO off threshold.

The soft-start and inhibit schematic diagram is shown in figure 11.

Figure 11. Soft-Start and inhibit functions Internal Circuit .

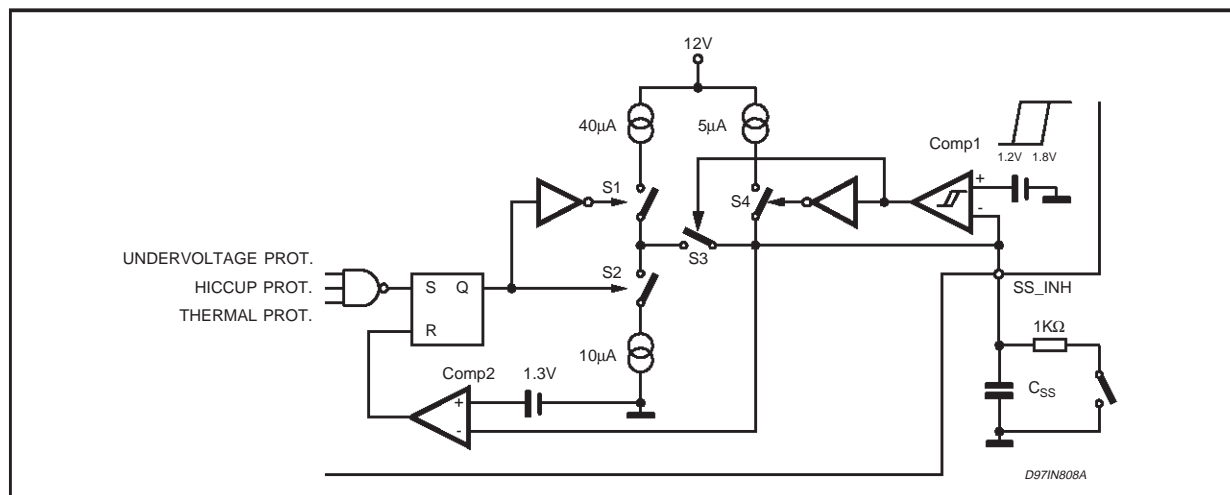

At device turn-on, the soft-start capacitor has no charge, with 0V at its terminals.

From 0V to 1.8V , switch S_3 is opened and S_4 is closed.

Soft-start capacitor is charged with $5\mu\text{A}$.

At 1.8V , comp1 change the output status, opening S_4 and closing S_3 , and the device starts to generate the PWM signal, rising smoothly the output voltage.

Till this moment, S_2 is opened, S_1 closed.

By closing S_3 , the soft-start capacitor is charged with $40\mu\text{A}$ reaching its saturation voltage.

This procedure is repeated at each V_{cc} turn-on.

Turning V_{cc} off, the soft-start capacitor is discharged with a constant $10\mu\text{A}$ (S_2 closed, S_3 closed, S_1 and S_4 open), from the moment when V_{cc} is crossing the UVLO off threshold.

The final discharge value is 1.2V .

In case of the C_{ss} is discharged using an external grounded element when the voltage at C_{ss} reaches the threshold of 1.3V Comp2 resets the flip fop, S_1 is closed, S_2 is opened and the $40\mu\text{A}$ current generator is activated.

The external switch, sinking some mA, discharges the soft-start under the 1.2V Comp1 threshold, opening S_3 and closing S_4 . At this point the device is in disable, sourcing only $5\mu\text{A}$ through pin 2.

When the external grounding element is removed, the device restarts charging the soft start capaci-

AN1061 APPLICATION NOTE

tance, initially, with 5µA till the voltage reaches the 1.8V threshold and Comp1 connects the 40µA charging current generator.

In case of thermal shutdown or overcurrent protection intervention the power is turned off and the flip flop turns off S2 and turns on S1. The soft-start is discharged till the voltage reaches the 1.3V threshold, and Comp2 resets the flip flop. S1 is closed, S2 is opened and the soft-start capacitance is charged again.

Figure 11a shows the systems signals during Inhibit, overcurrent and Vcc turn off.

t1 and t2 can be calculated by the following equations:

$$t1 = 0.36 \cdot C_{ss}; \quad t2 = \frac{V_o}{I_{ch} \cdot 6 \cdot D_{max}} \cdot C_{ss}$$

where Dmax is 0.95, C_{ss} is in µF and I_{ch} is in µA .

Soft-start time (t2) versus output voltage and C_{ss} is shown in Figure 12.

Thanks to the voltage feedforward, the start-up time (t2) is not affected by the input voltage.

Figure 13 shows the output voltage start-up using different soft-start capacitance values.

It is mandatory a minimum capacitor value of 22nF. The pin 2 cannot be left open.

Figure 11a. Timing Diagram in Inhibit, overcurrent and turn off condition

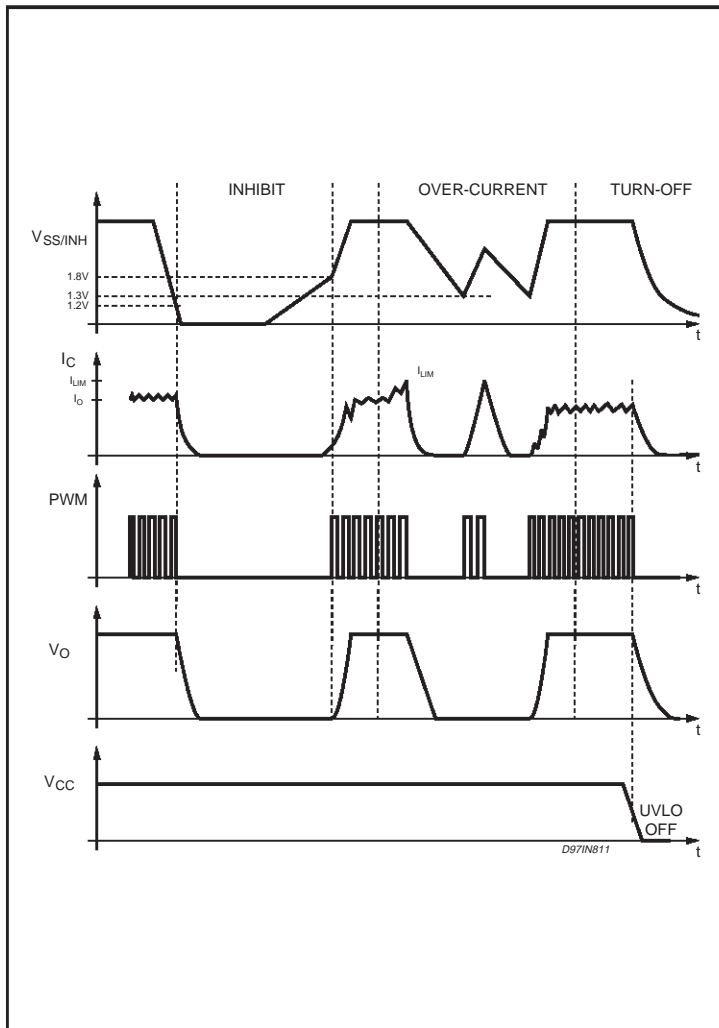
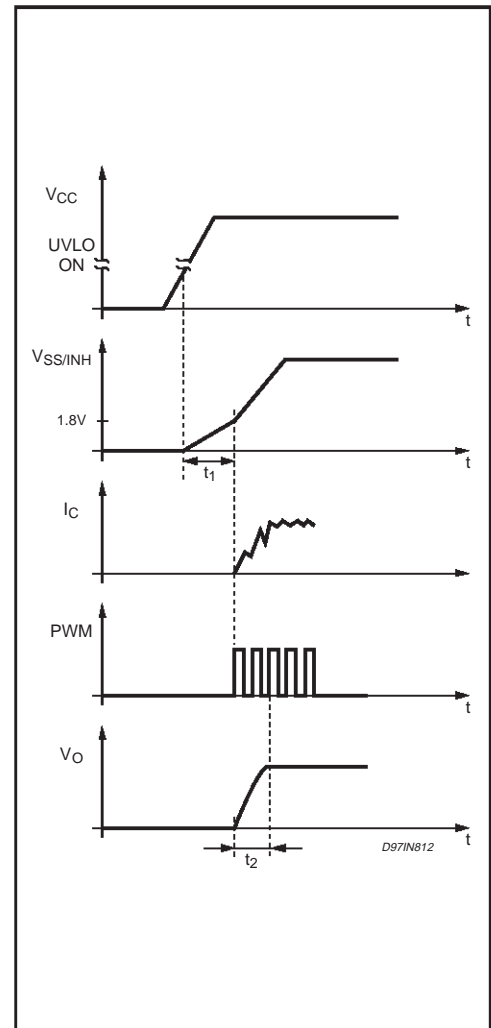

Figure 11b. Start up sequence.



Feedback disconnection

In case of feedback disconnection, the duty cycle increases versus the max allowed value bringing the output voltage close to the input supply. This condition could destroy the load.

To avoid this dangerous condition, the device is forcing a little current (1.4µA typical) out of the pin 8 (E/A Feedback). If the feedback is disconnected, open loop, and the impedance at pin 8 is higher than 3.5M Ohm, the voltage at this pin goes higher than the internal reference voltage located on the non-inverting error amplifier input, and turns-off the power device.

Figure 12. Soft start time(t_{ss}) vs V_O and C_{ss}

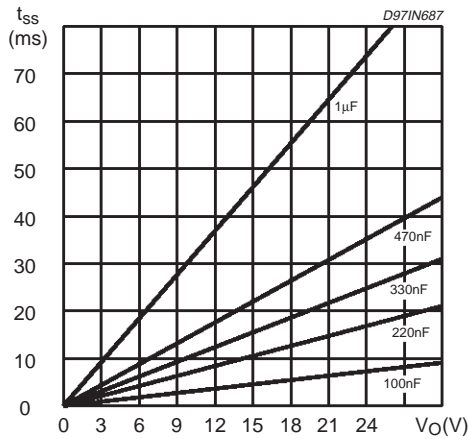
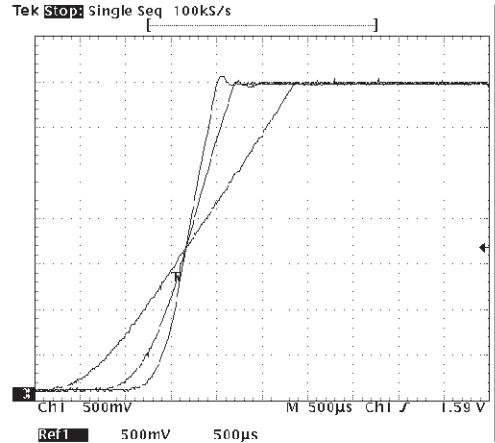

Figure 13. Output rising voltage with C_{ss} 56nF, 100nF, 220nF.



Zero load

In normal operation, the output regulation is also guaranteed because the bootstrap capacitor is recharged, cycle by cycle, by means of the energy flowing into the choke.

Under light load conditions, this topology tends to operate in burst mode, with random repetition rate of the bursts.

An internal new function makes this device capable of keeping the output voltage in full regulation with 1mA of load current only.

Between 1mA and 500µA, the output is kept in regulation up to 8% above the nominal value.

Here the circuitry providing the control :

- 1- a comparator located on the bootstrap section is sensing the bootstrap voltage; when this is lower than 5V, the internal power VDMOS is forced ON for one cycle and OFF for the next..
- 2- during this operation mode, i.e. 500µA of load current, the E/A control is lost. To avoid output over-voltages, a comparator with one input connected to pin 8, and the second input connected to a threshold 8% higher than nominal output, turns OFF the internal power device the output is reaching that threshold. When the output current, or rather, the current flowing into the choke, is lower than 500µA, that is also the consumption of the bootstrap section, the output voltage starts to increase, approaching the supply voltage.

Output Overvoltage Protection (OVP)

The output overvoltage protection, OVP, is realised by using an internal comparator, which input is connected to pin 8, the feedback, that turns-off the power stage when the OVP threshold is reached.

This threshold is typically 8% higher than the feedback voltage.

When a voltage divider is requested for adjusting the output voltage, the OVP intervention will be set at:

$$V_{ovp} = 1.08 \cdot V_{fb} \cdot (R_a + R_b) / R_b$$

where R_a is the resistor connected to the output.

Power Stage



AN1061 APPLICATION NOTE

The power stage is realised by a N-channel D-mos transistor with a V_{dss} in excess of 60V and typ. R_{dson} of 290mOhm (measured at the device pins).

To minimise the R_{dson} , means also to minimise the conduction losses.

But also the switching losses have to be taken into consideration, mainly for the two following reasons:

- a- they are affecting the system efficiency and the device power dissipation
- b- because they generate EMI.

TURN - ON

At turn-on of the power element, or better, the rise time of the current (di/dt) at turn-on is the most critical parameter to compromise.

At a first approach, it looks that the faster it is the rise time and the lower are the turn-on losses.

It's not completely true.

There is a limit, and it's introduced by the recovery time of the recirculation diode.

Above this limit, about 100A/usec, only drawbacks are obtained:

- 1- turn-on overcurrent is decreasing efficiency and system reliability
- 2- big EMI increasing.

The L4978 has been developed with a special focus on this dynamic area.

An innovative and proprietary gate driver, with two different timings, has been introduced.

When the diode reverse voltage is reaching about 3V, the gate is sourced with low current (see Figure 14) to assure the complete recovery of the diode without generating unwanted extra peak currents and noise.

After this threshold, the gate drive current is quickly increased, producing a fast rise time till the peak current, so maintaining the efficiency very high.

TURN - OFF

The turn-off behaviour, is shown at Figure 14.

Figure 15 shows the details of the internal power stage and driver, where at Q2 is demanded the turn-off of the power switch, S.

TYPICAL APPLICATION

Figure 16 shows the typical application circuit, where the input supply voltage, V_{cc} , can range from 8 to 55V operating, and the output voltage adjustable from 3.3V to 40V.

The selected components, and in particular input and output capacitors, are able to sustain the device voltage ratings, and the corresponding RMS currents.

Electrical Specification

Input Voltage range	8V-55V
Output Voltage	5.1V \pm 3% (Line, Load and Temperature)
Output ripple	34mV
Output Current range	1mA-2A
Max Output Ripple current	20% I_{omax}
Current limit	3A
Switching frequency	100kHz
Target Efficiency	85% @ 2A $V_{in} = 55V$ 92% @ 0.5A $V_{in} = 12V$

Main components description

Figure 14. Turn on and Turn off (pin 2, 3)

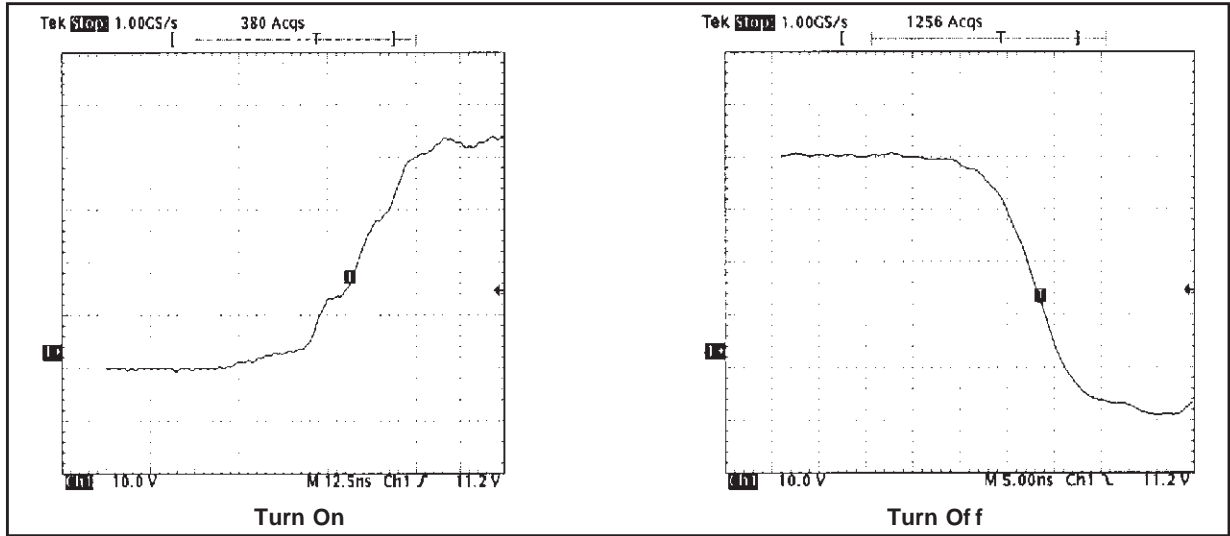
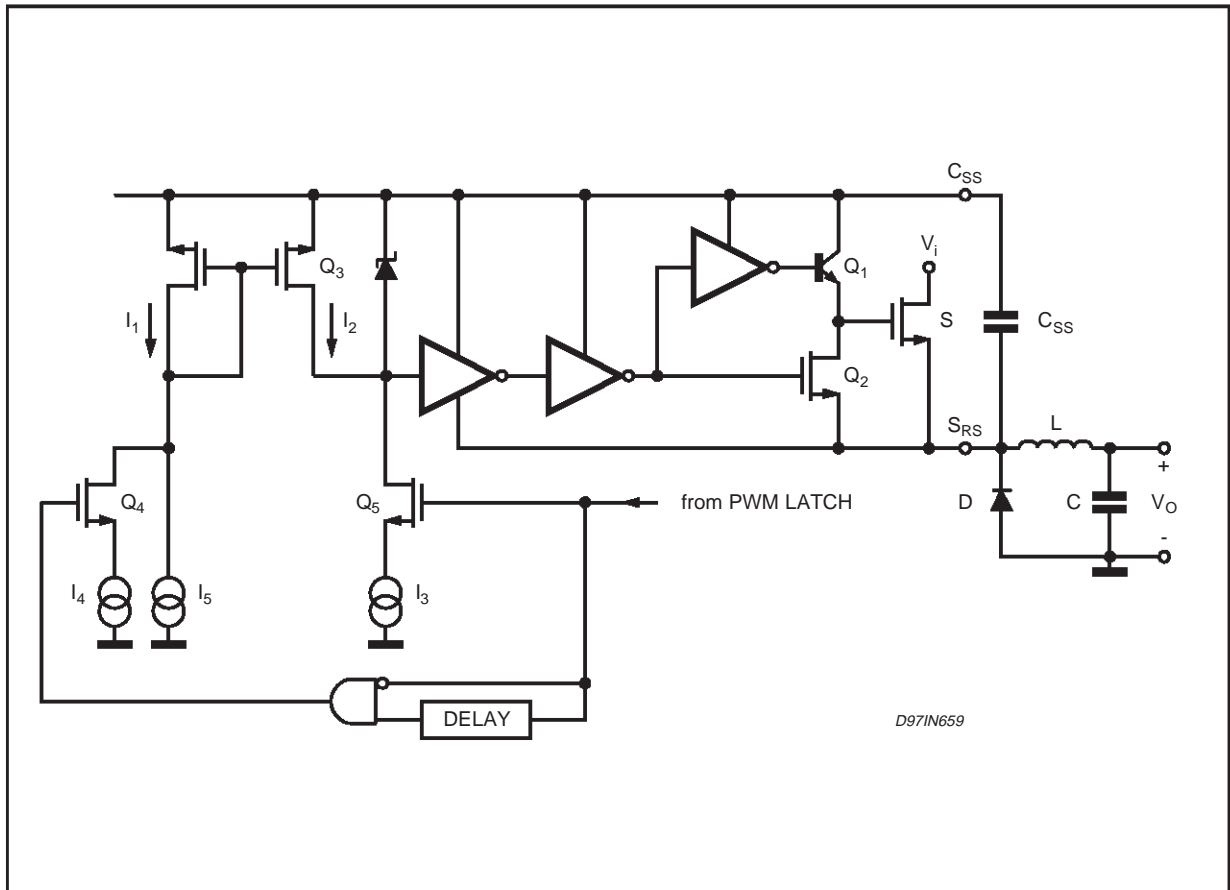

Figure 15. Power stage internal circuit.



INPUT CAPACITOR

The input capacitors have to be able to support the max input operating voltage of the device and the max rms input current.

Figure 16. Application Circuit

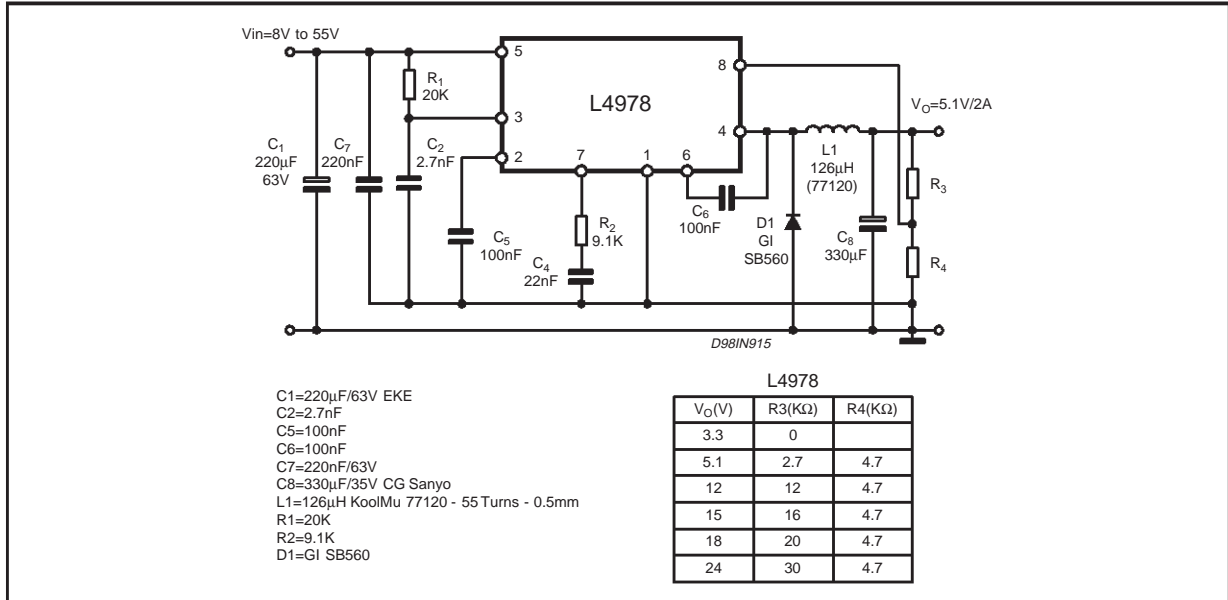

The input current is squared and the quality of these capacitors has to be very high to minimise its power dissipation generated by the internal ESR, improving the system reliability. Moreover, input capacitors are also affecting the system efficiency.

The max Irms current flowing through the input capacitors is:

$$I_{rms} = I_o \cdot \sqrt{D - \frac{2 \cdot D^2}{\eta} + \frac{D^2}{\eta^2}}$$

where η is the expected system efficiency, D is the duty cycle and I_o the output dc current. This function reaches the maximum value at D = 0.5 and the equivalent rms current is equal to I_o/2.

The following diagram is the graphical representation of the above equation, with an estimated efficiency of 85% at different output currents.

The maximum and minimum duty cycles are:

$$D_{max} = \frac{V_o + V_f}{V_{inmin} + V_f} = 0.66$$

$$D_{min} = \frac{V_o + V_f}{V_{inmax} + V_f} = 0.1$$

where V_f is the freewheeling diode forward voltage.

Figure 17. Efficiency vs Output Current

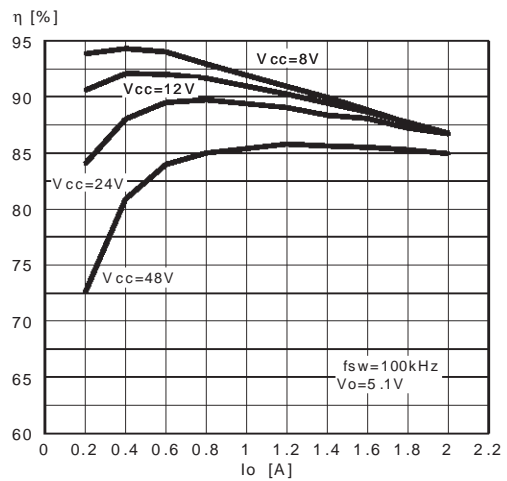

This formula is not taking into account the power mos R_{dson} , considering negligible the inherent voltage drop, respect input and output voltages.

At full load, 2A and $D = 0.5\%$ the rms capacitor current to be sustained is of 1A.

The selected EKE 220 μ F/63V Roderstain is able to support this current.

Figure 18. Input Capacitance rms current vs duty cycle

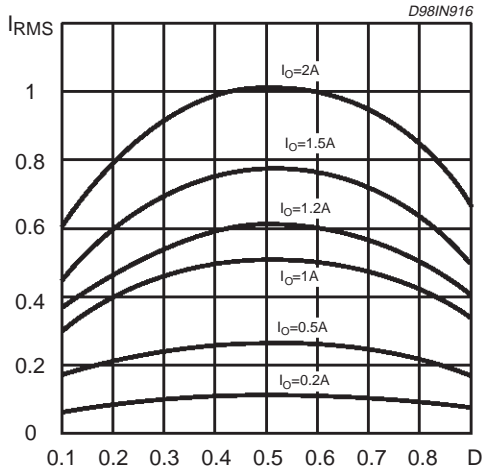

Inductor Selection

The inductor ripple current is fixed at 20% of I_{omax} and is 0.4A, the inductor needed is:

$$L = (V_o + V_f) \cdot \frac{(1 - D_{min})}{\Delta I_o \cdot f_{sw}} = 126\mu H \text{ (eq1)}$$

The $L \cdot I_o^2$ is 0.53 and the size core chose is 77120 (125 μ) Magnetics KoolM μ material. At full load the magnetising force is about 25 Oersted, so, in order to compensate a 30% reduction of inductance due to the DC current level, they are wiring 55 turns, which corresponds to 213 μ H of inductance at light load.

It is possible to graficate the Eq 1 as a function of V_o and V_{inmax} at 100kHz and 200kHz (see Figure 19a-b).

These curves are useful to define the inductor value immediately.

-core losses

Core losses are proportional to the magnetic flux swing into the core material. To evaluate the flux swing is used the following formula:

$$\Delta B = \frac{L \cdot \Delta I_o}{N_o \cdot A_{Ie} \cdot 10^{-4}} = 477 \text{ Gauss}$$

where A_{Ie} is the core cross section [m^2].

The chosen core material family has an empirical equation to calculate the losses:

Figure 19a. Inductor needed as a function of maximum input voltage and output voltage at fsw=100kHz

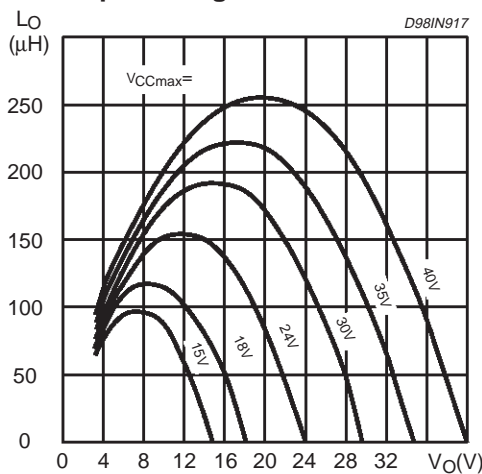
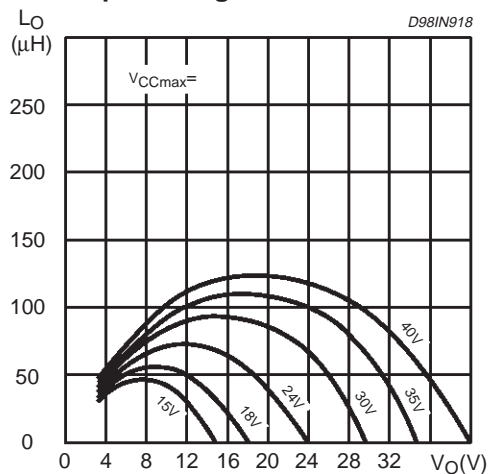

Figure 19b. Inductor needed as a function of maximum input voltage and output voltage at fsw=200kHz



AN1061 APPLICATION NOTE

$$P_I = \Delta B^2 \cdot f_{sw}^{1.5} \cdot V_I = 180mW$$

Where V_I is the core volume in cm^3 , ΔB is expressed in KGauss and f_{sw} in KHz. The core increasing temperature is:

$$\Delta T = \left(\frac{P_I}{13.6} \right)^{0.833} = 8.5^\circ C$$

where P_I is expressed in mW.

Output Capacitor

The selection of C_{out} is driven by the output ripple voltage required, 1% of V_o . This is defined by the output capacitance ESR and with the maximum ripple current (0.4A) the maximum ESR is:

$$ESR = \Delta V_o / \Delta I_o = 0.051 / 0.4 = 127.5m\Omega$$

The selected capacitance is 330 μ F/35V CG Sanyo with ESR = 86m Ω and the ripple voltage is 0.67% of V_o (34mV).

The drop due to a fast load variation of 1A produce an output drop of :

$$ESR \cdot \Delta I_o = 86mV$$

that is the 1.6% of the output voltage.

Output capacitance has to support a load transient until the inductor current reaches the increased current. The output drop during an output current variation is:

$$\Delta V_o = \frac{(\Delta I_o)^2 \cdot L_o}{2 \cdot C_o \cdot (V_{inmin} \cdot D_{max} - V_o)} \quad Eq(2)$$

Where ΔI_o is the current load variation (0.5A to 2A), D_{max} is the maximum duty cycle (0.95), V_o is 5.1V and L_o is 126 μ H .

Equation 2, normalised by V_o is represented in the following diagram(Figure 20) as a function of the minimum input voltage.

These curves are represented for different output capacitor 220 μ F, 330 μ F, 2x330 μ F.

Compensation Network

The complete control loop block diagram is shown in Figure 21

The transfer functions described are:

Error amplifier and compensation block

$$A_{(s)} = \frac{A_{vo} \cdot (1 + s \cdot R_c \cdot C_c)}{s^2 \cdot R_o \cdot C_o \cdot R_c \cdot C_c + s \cdot (R_o \cdot C_c + R_o \cdot C_o + R_c \cdot C_c) + 1}$$

Figure 20. Output drop (%) vs minimum input voltage

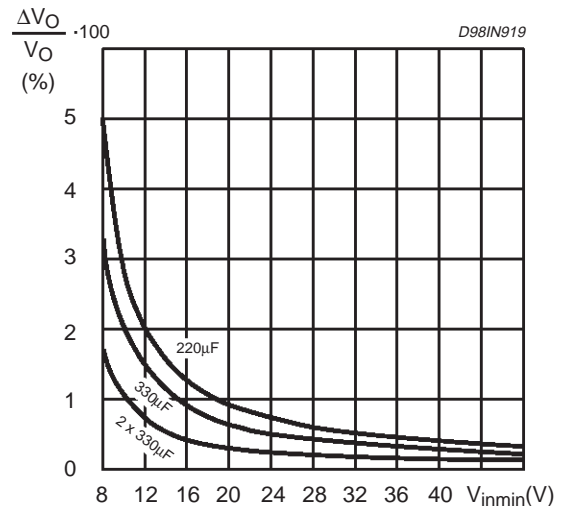

C_o is the parallel between the output capacitance and the external capacitance of the Error Amplifier
 R_c and C_c are the compensation values

Figure 21. Block diagram compensation loop

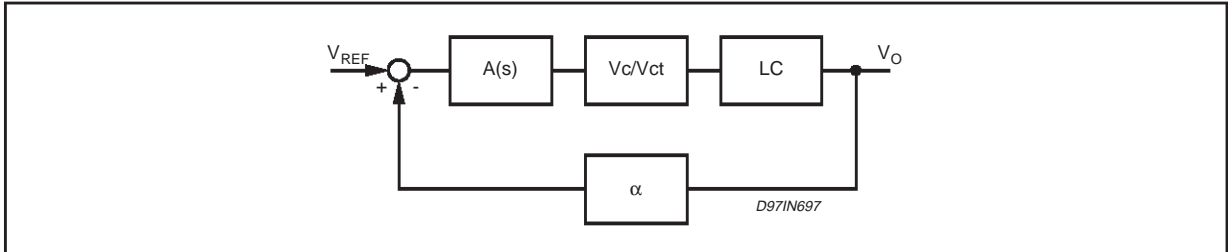

LC filter

$$A_{o(s)} = \frac{1 + R_{esr} \cdot C_{out} \cdot s}{L \cdot C_{out} \cdot (1 + \frac{R_{esr}}{R_L}) \cdot s^2 + (R_{esr} \cdot C_{out} + \frac{L}{R_L}) \cdot s + 1}$$

PWM gain

$$\frac{V_{cc}}{V_{ct}} = \frac{V_{cc} \cdot 6}{V_{cc} - 1} \approx 6$$

where V_{ct} is the peak to peak sawtooth oscillator.
 Voltage divider

Figure 22. Error Amplifier Compensation Circuit

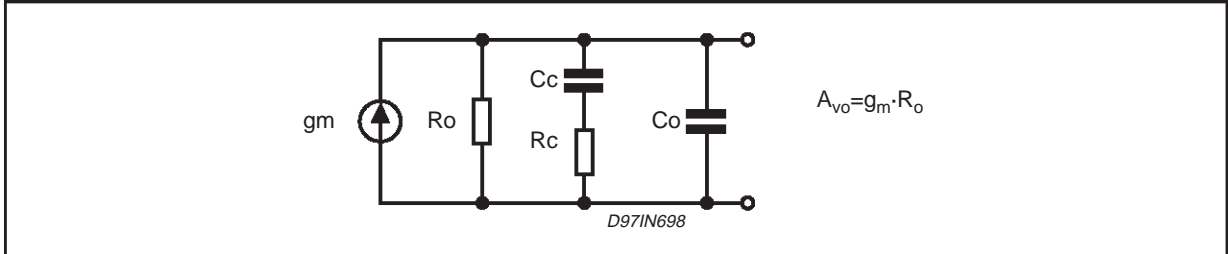

$$\alpha = \frac{R4}{R3 + R4}$$

The Error Amplifier basic characteristics are:

Figure 23. Output Filter

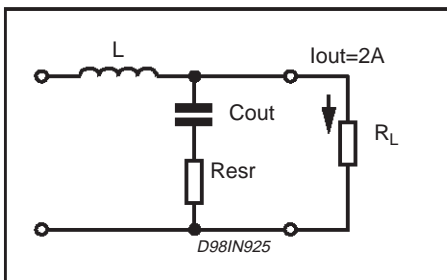

- $R_o = 1.2M\Omega$
- $A_{vo} = 57dB$
- $C_o = 220pF$

The poles and zeros value are:

$$F_o = \frac{1}{2 \cdot \pi \cdot R_{esr} \cdot C_{out}} = \frac{1}{2 \cdot \pi \cdot 0.086 \cdot 330 \cdot 10^{-6}} = 5.6KHz$$

$$F_p = \frac{1}{2 \cdot \pi \cdot \sqrt{L \cdot C_{out}}} = \frac{1}{2 \cdot \pi \cdot \sqrt{126 \cdot 10^{-6} \cdot 330 \cdot 10^{-6}}} = 780\text{Hz}$$

$$F_{ocomp} = \frac{1}{2 \cdot \pi \cdot R_c \cdot C_c} = \frac{1}{2 \cdot \pi \cdot 9.1 \cdot 10^3 \cdot 22 \cdot 10^{-9}} = 795\text{Hz}$$

$$F_{p1} = \frac{1}{2 \cdot \pi \cdot R_o \cdot C_c} = \frac{1}{2 \cdot \pi \cdot 1.2 \cdot 10^6 \cdot 22 \cdot 10^{-9}} = 6.032\text{Hz}$$

$$F_{p2} = \frac{1}{2 \cdot \pi \cdot R_c \cdot C_o} = \frac{1}{2 \cdot \pi \cdot 9.1 \cdot 10^3 \cdot 220 \cdot 10^{-12}} = 80\text{KHz}$$

The compensation is realised choosing the F_{ocomp} nearly the frequency of the double pole due to the LC filter.

Using compensation network $R_1 = 9.1\text{K}$, $C_6 = 22\text{nF}$ and $C_5 = 220\text{pF}$ obtain the Gain and Phase Bode plot of Figures 24-25. Is possible to omit C_5 because does not influence the system stability but is useful only to reduce the noise. The cut off frequency and a phase margin are:

$$F_c = 3.7\text{KHz}; \quad \text{Phase margin} = 21^\circ$$

APPLICATION IDEAS

Compensation of voltage drop along the wires.

For supplying a remote load, without using sensing wires, the below application shows how to compensate the voltage drop along the wires.

If R_z is the total resistance of the line, fixing the resistor R_k (see Figure 1), to a value given by the below formula :

Figure 24. Gain Bode open loop plot

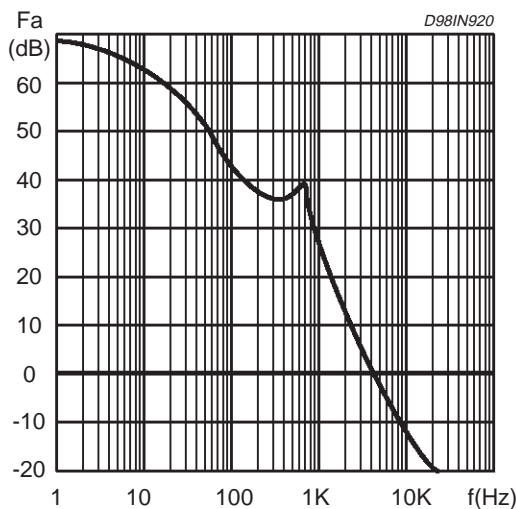
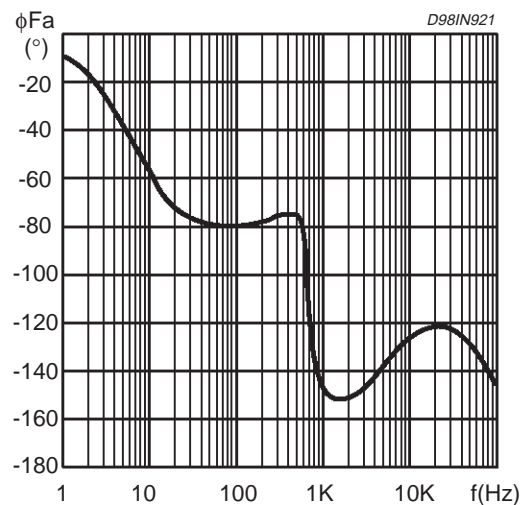

Figure 25. Phase Bode open loop plot



$$R_k = R_2 \cdot \frac{R_z}{R_1} ,$$

the regulated load voltage, V_L , is :

$$V_L = R_z \cdot I_q + (R_1 + R_2) \cdot \frac{1}{R_2} \cdot V_{ref}$$

where V_{ref} is the feedback voltage reference of 3.3V and I_q is the device quiescent current (typ. 2.5mA).

The C_{add} capacitor has to be chosen so that the frequency, given by $1/[2\pi C_{add} \cdot R_1 R_2 / (R_1 + R_2)]$, is around two decades below the switching frequency.

It follows a table for R_k choice with, for example, a line resistance, $R_z=0.5\Omega$:

Figure 27. Compensation of Voltage Drop along the Wires

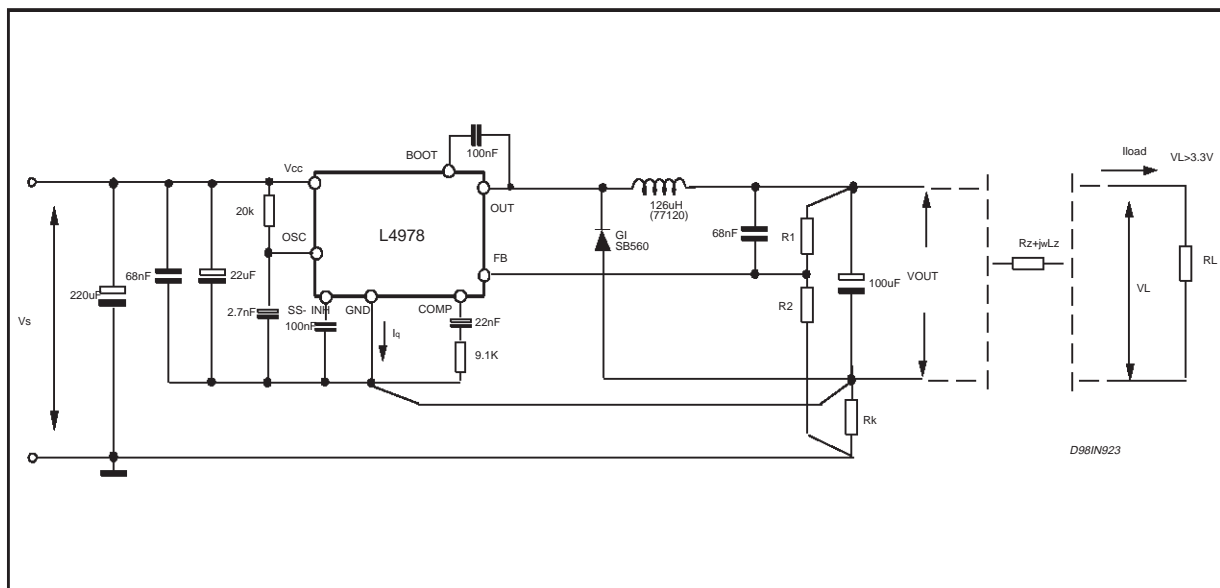
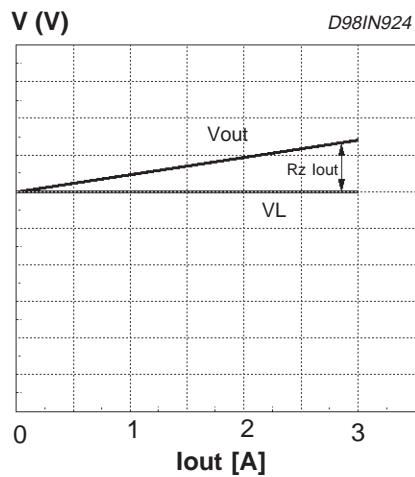

Table for RK choice

Vload(V)	R1(Ω)	R2(Ω)	Rk(Ω)
5.1	2.43K	4.7K	0.97
12	12.1K	4.7K	0.19
24	28.7K	4.7K	0.08

Figure 28. Output Voltage vs. Output Current



Information furnished is believed to be accurate and reliable. However, STMicroelectronics assumes no responsibility for the consequences of use of such information nor for any infringement of patents or other rights of third parties which may result from its use. No license is granted by implication or otherwise under any patent or patent rights of STMicroelectronics. Specification mentioned in this publication are subject to change without notice. This publication supersedes and replaces all information previously supplied. STMicroelectronics products are not authorized for use as critical components in life support devices or systems without express written approval of STMicroelectronics.

The ST logo is a registered trademark of STMicroelectronics

© 2000 STMicroelectronics – Printed in Italy – All Rights Reserved

STMicroelectronics GROUP OF COMPANIES

Australia - Brazil - China - Finland - France - Germany - Hong Kong - India - Italy - Japan - Malaysia - Malta - Morocco -
Singapore - Spain - Sweden - Switzerland - United Kingdom - U.S.A.

<http://www.st.com>



LittleDiode supplies new, hard to find or obsolete electronic components and semiconductors all over the world.

With over two million different components listed you are sure to find the part you need.

Feel free to visit us today at our online store:

LittleDiode.com

Looking forward to providing you with the best possible service.