

Application Note

QUICK CS6420 SPEAKERPHONE INTERFACE

This application note describes a quick interface for the Crystal Semiconductor CS6420 speakerphone device to an existing analog speakerphone. The electrical connections to the speakerphone take advantage of standard signals present in all analog speakerphones. Connections are made to the Tip and Ring of an analog telephone line and the CS6420 uses the speakerphone's speaker and microphone for its acoustic interface. Figure 1 illustrates the system connections.

Minor modifications are made to the speakerphone to gain access to certain signals and wires. Six signals are connected between the target speaker-

phone and the CS6420 circuit card. The phone's speaker and microphone wires are disconnected from the speakerphone's circuitry and brought to the CS6420 circuit card. This provides the CS6420's acoustic interface and accounts for four of the six signals (SPKR+, SPKR-, MIC+ and MIC-). With the CS6420 connected to the speaker and microphone, hands-free full duplex operation and speaker volume control are available. The Tip and Ring signals in the speakerphone are not disconnected from the speakerphone's circuitry. The connections are made in parallel keeping the speakerphone's keypad functional.

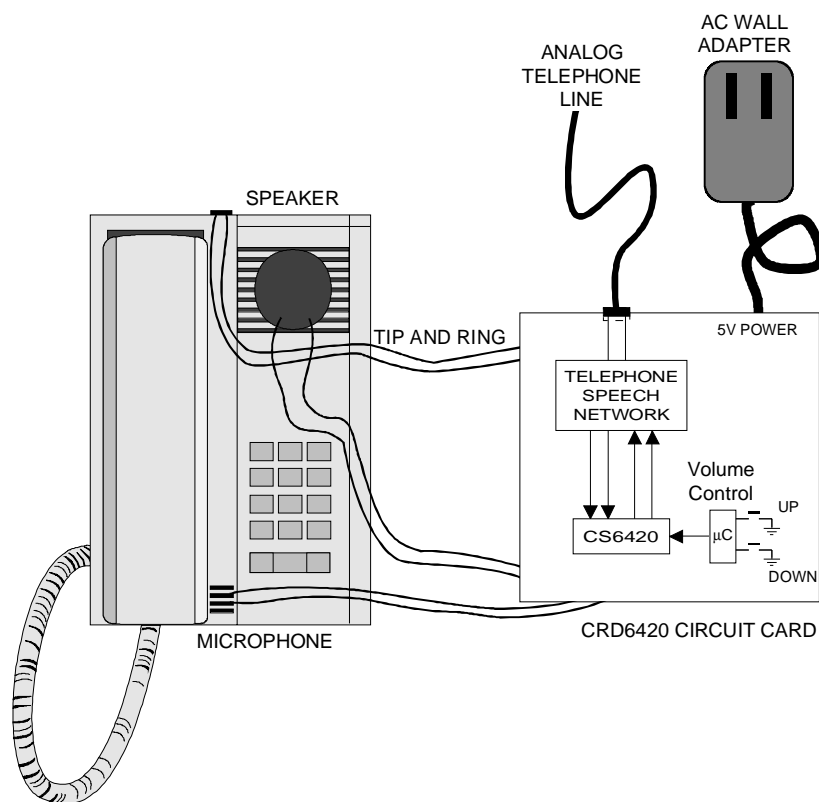

Figure 1. Speakerphone System Connections

This configuration permits easy evaluation of hands-free communication with a full duplex speakerphone. The speaker and microphone are housed in an actual chassis, providing a realistic environment. Various speakerphone designs can be quickly tested since standard analog signals are passed between the speakerphone and CS6420 circuit card. This method also uses the speakerphone's (tone) dialer.

Note that the performance of this system is dependent on the speakerphone used. In general the design criteria for full duplex speakerphones is much more stringent than for half duplex phones. In particular, distortion performance and acoustic coupling control are critical to good full duplex design. It is relatively easy to get the modified half-duplex speakerphone to work in full-duplex; however, its performance may suffer, particularly in near-end speaker volume and in idle channel noise in the transmit direction. Additionally, any distortion introduced by the speaker or the phone housing will result in uncancelled echo perceived at the far end.

The CS6420 circuit card interfaces to the telephone network via the Tip and Ring signals of the analog telephone line. The Tip and Ring signals are routed to a telephone speech network which converts the 2-wire analog telephone signal to 4-wire transmit and receive signals. The receive and transmit signals are interfaced to the CS6420's Network In (NI) and Network Out (NO) ports, respectively. The circuit for the POTS (Plain Old Telephone Service) analog telephone line interface is shown in Figure 2.

The 2-to-4 wire telephone hybrid is implemented with a Motorola MC34014. The MC34014 (U5) is a standard speech network meant for connection to the Tip and Ring lines through a polarity bridge (D6-D9). The discrete components surrounding U5 are as suggested by the MC34014 data sheet. The components which set the dc voltage characteristics have been omitted since this is established by

the speech network in the speakerphone. (Recall that the speakerphone's Tip and Ring signals remain connected to the POTS line in order to utilize the phone's keypad.) The omitted components include a resistor connected to LR (U5-13) and a capacitor connected to LC (U5-12).

Connection to the analog telephone line is made through J1, which is an RJ11 receptacle. This receptacle is a standard telephone connector that connects to the typical telephone cable provided with telephones. A DPDT switch (S1) is used to switch between ON HOOK and OFF HOOK.

The transmit and receive signals from the MC34014 are buffered and AC coupled using a Motorola op-amp MC33078 (U3). The gain of the op-amp circuit is set such that the NI amplitude is within the CS6420's limits of 1 V_{rms} and the CS6420's NO signal level, also 1 V_{rms}, adjusted to meet the MC34014's TX requirements. R9 and R10 create a voltage divider that establishes a voltage to bias the op-amp's inputs at 2.5 volts.

The schematic for the CS6420 (U1) circuitry is shown in Figure 3. The circuitry is identical to the typical connections described in the CS6420 data sheet and incorporated on the CDB6420 evaluation board.

Figures 4 and 5 are schematics for the speaker driver and microphone bias respectively. The Motorola MC34119 (U2) provides the capability to drive speaker loads down to 8 ohms. The microphone bias circuitry provides the necessary constant current source for an electret microphone. Both of these circuits are used on the CDB6420 evaluation board and are described in the CDB6420 data sheet.

A microcontroller is interfaced to the CS6420 to adjust the default settings and control speaker volume. Figure 6 contains a schematic using the Microchip PIC16C84 (U4) microcontroller. U4 writes control words to the CS6420's four control registers using a 3-wire interface ($\overline{\text{DRDY}}$, STROBE,

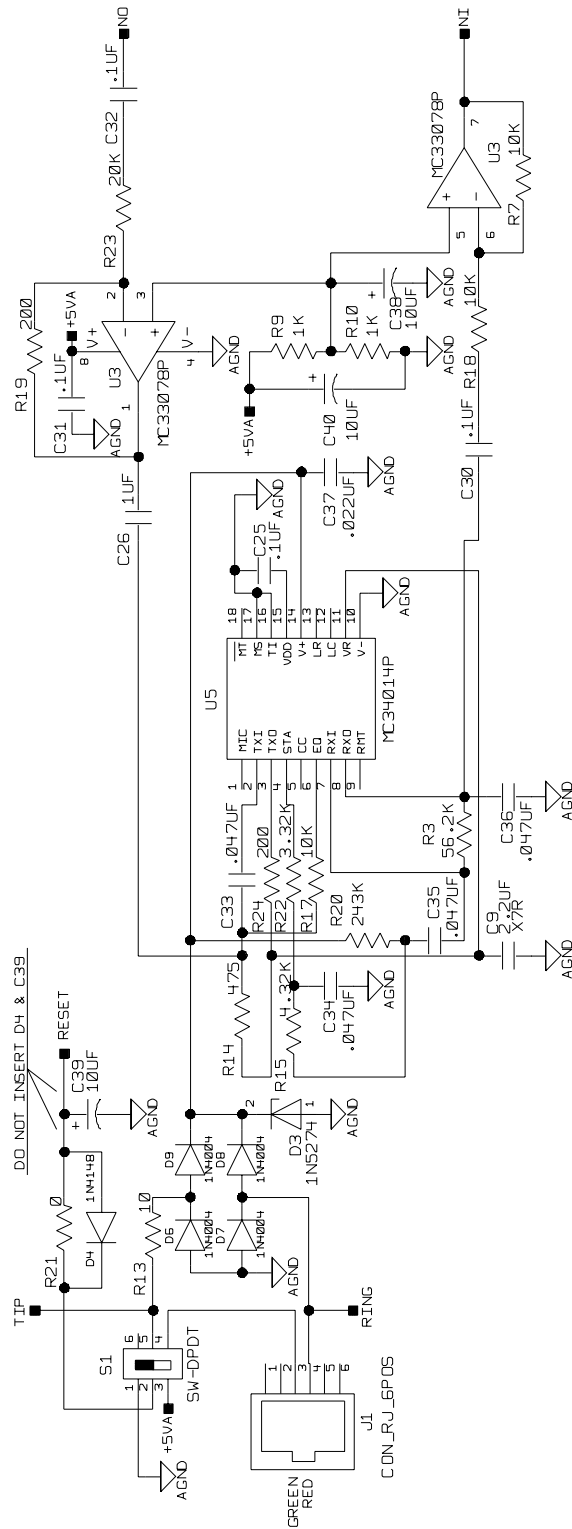

Figure 2. Interface to the Tip and Ring Signals of a POTS Line

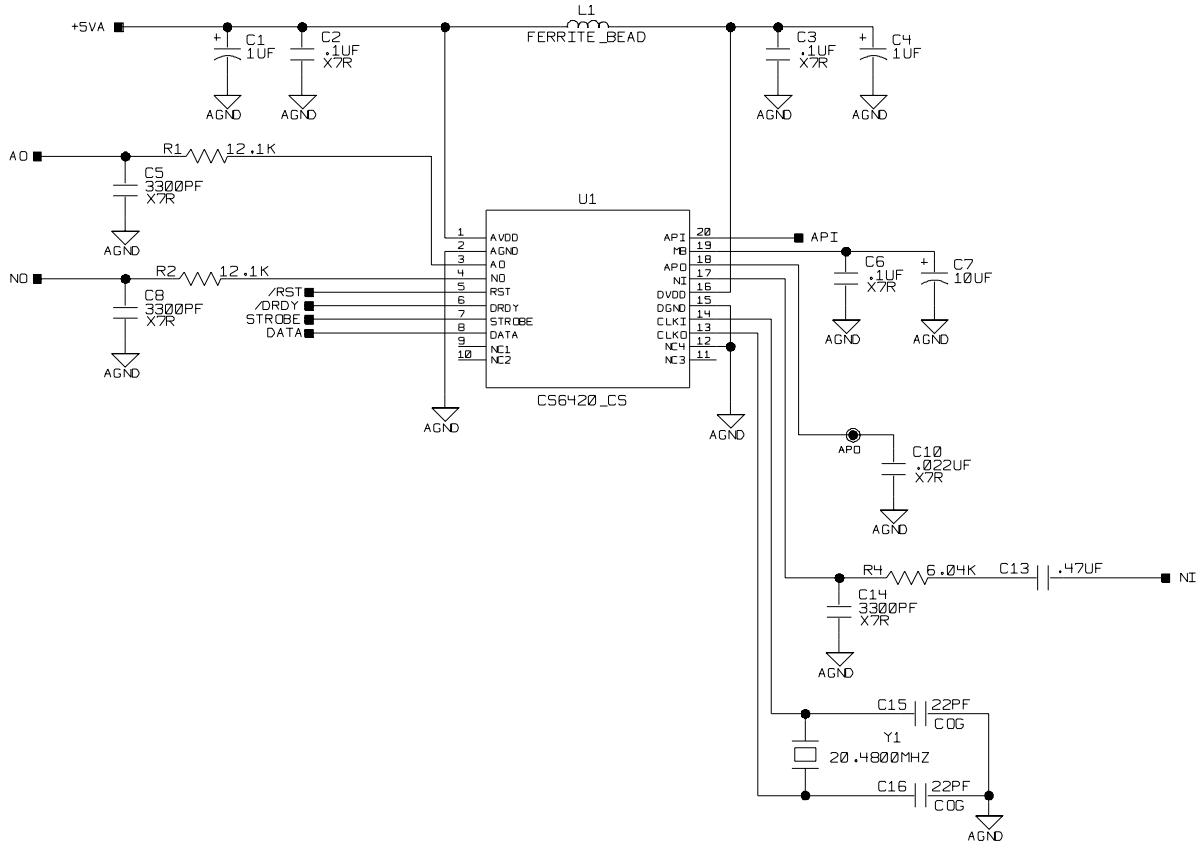

Figure 3. CS6420 Connection Diagram

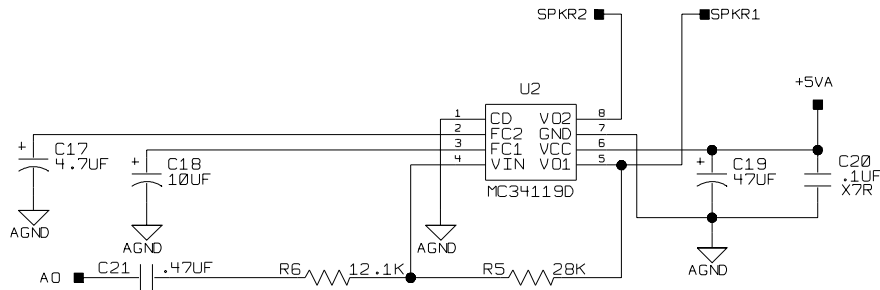

Figure 4. Speaker Driver Circuit

and DATA). The microcontroller reads one of the two momentary switches that provide signals to either increase or decrease the speaker volume. The input signals are deciphered, and the volume control word is sent to the CS6420. The digital interface and control words are described in the CS6420 data sheet. The assembly code for the PIC16C84 is provided at the end of this application note.

Figure 7 illustrates the power supply circuitry. The circuitry is designed to use a common +6 V DC power supply. The supply used should be able to source a minimum of 200mA. A diode (D5) provides a diode drop to reduce the voltage to around 5 volts. Z1 is a zener diode added to provide over-voltage and polarity inversion protection. For noise performance, the 5 volt digital voltage (+5 VD) is filtered using a ferrite bead.

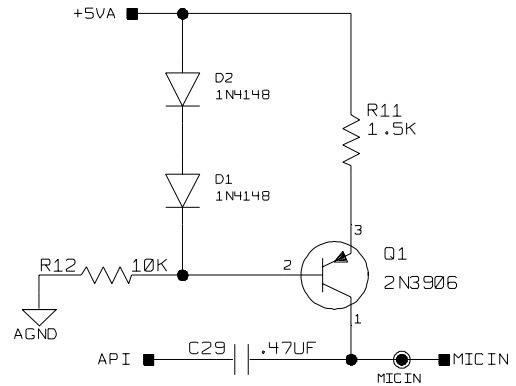

Figure 5. Microphone Bias Circuit

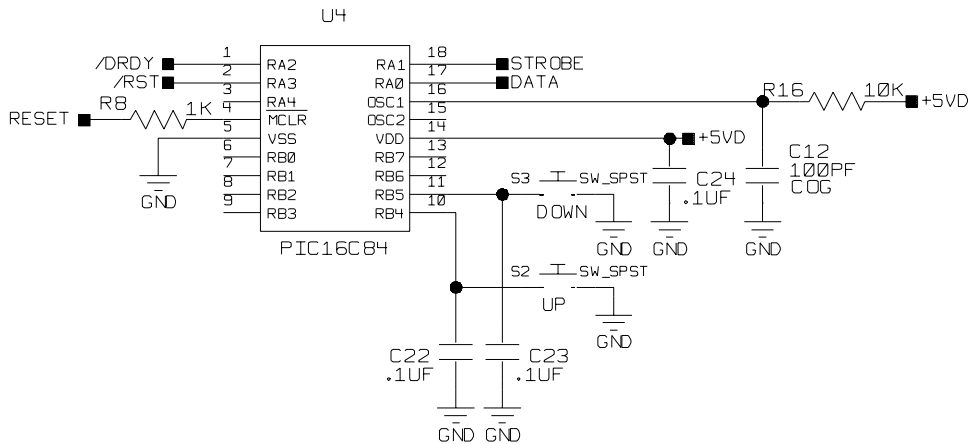

Figure 6. Microcontroller Interface Circuit

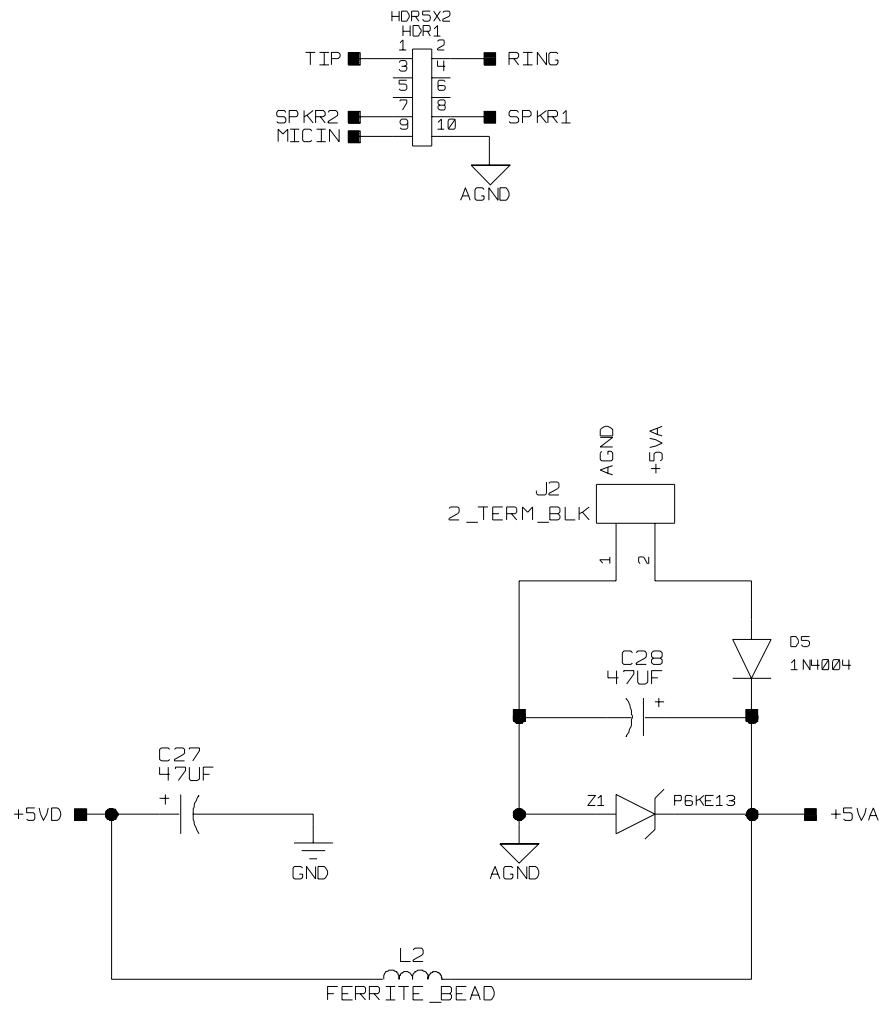

Figure 7. Power Supply Circuitry and Phone Connection Pinout

PIC16C84 ASSEMBLY CODE

```

*****
;*
;* File:          crd6420.asm
;* Date:         May 12, 1997
;*
;* PIC16C84
;*
;* Program entry point is at routine "Main". The entry point
;* is address 0x05
*****
;*
;* Program is designed to provide simple volume control for the CS6420
;* in a CDB6420-based demo. Two buttons, one to increase volume and
;* one to decrease volume are connected to PortB of the PIC16C84. Four
;* PortA pins are used to control the CS6420's Microcontroller Interface.
;*
*****
;***** Memory Map Equates
INDF          equ      0x00          ; Indirect Address Register
STATUS       equ      0x03          ; STATUS register equate
RPO          equ      0x05          ; Register Bank Select Bit
ZERO        equ      0x02          ; Represents the Zero Bit in Status Reg
CARRY       equ      0x00          ; Represents the Carry Bit in Status Reg
FSR         equ      0x04          ; File Select Register
PORTA       equ      0x05          ; General Purpose I/O Port
PORTB       equ      0x06          ; General Purpose I/O Port
INTCON      equ      0x0B          ; INTCON register equate
GIE         equ      0x07          ; Represents the GIE bit in IntCon Reg
RBIE        equ      0x03          ; Represents the RBIE bit in IntCon Reg
RBIF        equ      0x00          ; Represents the RBIF bit in IntCon Reg
OPT_REG     equ      0x81          ; OPTION register equate
RBPU        equ      0x07          ; Represents the RBPU bit in Option Reg
TRISA       equ      0x85          ; Data Direction Control For Port A
TRISB       equ      0x86          ; Data Direction Control For Port B
DATAIN      equ      0x00          ; Port A bit 0
STROBE      equ      0x01          ; Port A bit 1
DRDY        equ      0x02          ; Port A bit 2
RST         equ      0x03          ; Port A bit 3
INC         equ      0x04          ; Port B bit 4
DEC         equ      0x05          ; Port B bit 5

;***** Ram Memory Equates
Reg0Hi      equ      0x0C          ; Upper 8 bits of Reg0
Reg1Hi      equ      0x0D          ; Upper 8 bits of Reg1
Reg2Hi      equ      0x0E          ; Upper 8 bits of Reg2
Reg3Hi      equ      0x0F          ; Upper 8 bits of Reg3
Reg0Lo      equ      0x10          ; Lower 8 bits of Reg0
Reg1Lo      equ      0x11          ; Lower 8 bits of Reg1
Reg2Lo      equ      0x12          ; Lower 8 bits of Reg2
Reg3Lo      equ      0x13          ; Lower 8 bits of Reg3
RegHi       equ      0x14          ; Upper 8 bits of Transmit Reg
RegLo       equ      0x15          ; Lower 8 bits of Transmit Reg
Temp        equ      0x16          ; Temporary byte
RVol        equ      0x17          ; Volume control variable
Count       equ      0x18          ; Loop counter
Port        equ      0x19          ; PortB temporary value
DelayTime   equ      0x1a          ; Delay counter
DelayMore   equ      0x1b          ; Delay counter

```

```
*****
;*
;*   Program Code
*****
        processor    16C84           ; Set Processor Type
        org          0x00           ; Reset Vector
        goto         Main           ; Start at Main

        org          0x04           ; Interrupt Vector
        goto         ISR            ; Service the Interrupt
*****
;*
;* Routine - Main
;* Input - none
;* Output - none
;* This is the entry point to the program
*****
        org          0x05

Main                                         ; Start from Reset Vector

***** Initialize System and Perform SELF OFFSET Calibration
        CALL        Initialization        ; Initialize the system
        CALL        PowerOn              ; Powerup the CS6420
Here    GOTO        Here                  ; Infinite loop
```

```

;*****
;*
;* Routine - Initialization
;* Input - none
;* Output - none
;* Set up default control bytes, default volume setting, port pins
;*****
Initialization
; Set up default control bytes ;This configuration has the microphone tied directly to APO.
; Reg0Hi
MOV LW 0x20 ;mic preamp off, RVol = +24 dB, TGain = +12 dB
MOV WF Reg0Hi
; Reg0Lo
MOV LW 0x58
MOV WF Reg0Lo
; Reg1Hi
MOV LW 0x20 ;TVol = +21 dB, RGain = +12 dB
MOV WF Reg1Hi
; Reg1Lo
MOV LW 0x7a
MOV WF Reg1Lo
; Reg2Hi
MOV LW 0x08 ;RHDet = 6 dB, RSThd = 6 dB, PCSen = low
MOV WF Reg2Hi
; Reg2Lo
MOV LW 0x2c
MOV WF Reg2Lo
; Reg3Hi
MOV LW 0x0a ;THDet = 6 dB, TSAAtt = 24 dB
MOV WF Reg3Hi
; Reg3Lo
MOV LW 0x0b
MOV WF Reg3Lo
; Set up default volume setting
; RVol = 0x02 (24 dB) (max of 0x1f)
MOV LW 0x02
MOV WF RVol
; Set up port pins
; 2 inputs (increase volume, decrease volume)
; 4 outputs (/RST, /DRDY, STROBE, DATAIN)
CLR F PORTA ; Initialize PORTA by setting output
; data latches.
CLR F PORTB ; Initialize PORTB by setting output
; data latches.
BSF STATUS, RP0 ; Select Bank 1
MOV LW 0x00 ; Value used to initialize direction
MOV WF TRISA ; Set PortA as outputs
MOV LW 0x30 ; Value used to initialize direction
MOV WF TRISB ; Set PortB RB5 and RB4 as inputs
BCF OPT_REG, RBPU ; Enable weak pullups on PortB
BCF STATUS, RP0 ; Select Bank 0
MOV LW 0xff ; bring all port pins high
MOV WF PORTA
MOV LW 0x0f ; bring all port pins high
MOV WF PORTB
BSF INTCON, RBIE ; Enable interrupt on PortB change
BSF INTCON, GIE ; Enable all interrupts
RETURN

```

```

;*****
;
;* Routine - Power On
;* Input - none
;* Output - RegXHi,RegXLo
;* Reset CS6420 and initialize registers
;*****
PowerOn
    BCF      PORTA,RST      ; bring /RST lo
    BSF      PORTA,RST      ; bring /RST hi
                                ; Write Reg0 (RegHi=Reg0Hi, RegLo=Reg0Lo)
    CALL     Delay          ; hold time
    MOVF     Reg0Hi,0       ; move Reg0Hi to W
    MOVWF    RegHi         ; move W to RegHi
    MOVF     Reg0Lo,0      ; move Reg0Lo to W
    MOVWF    RegLo        ; move W to RegLo
    CALL     WriteReg
                                ; Write Reg1 (RegHi=Reg1Hi, RegLo=Reg1Lo)
    MOVF     Reg1Hi,0      ; move Reg1Hi to W
    MOVWF    RegHi         ; move W to RegHi
    MOVF     Reg1Lo,0     ; move Reg1Lo to W
    MOVWF    RegLo        ; move W to RegLo
    CALL     WriteReg
                                ; Write Reg2 (RegHi=Reg2Hi, RegLo=Reg2Lo)
    MOVF     Reg2Hi,0     ; move Reg2Hi to W
    MOVWF    RegHi         ; move W to RegHi
    MOVF     Reg2Lo,0     ; move Reg2Lo to W
    MOVWF    RegLo        ; move W to RegLo
    CALL     WriteReg
                                ; Write Reg3 (RegHi=Reg3Hi, RegLo=Reg3Lo)
    MOVF     Reg3Hi,0     ; move Reg3Hi to W
    MOVWF    RegHi         ; move W to RegHi
    MOVF     Reg3Lo,0     ; move Reg3Lo to W
    MOVWF    RegLo        ; move W to RegLo
    CALL     WriteReg
    CALL     UpdateRVol    ; Update RVol
    RETURN
;*****
;
;* Routine - ISR
;* Input - none
;* Output - none
;* The ISR calls IncreaseVolume or DecreaseVolume as appropriate
;*****
ISR
    MOVF     PORTB,0       ; move contents of PortB to W
    MOVWF    Port         ; save contents to Temp for bit test
    BTFSS    Port,INC      ; if INC is high, is DEC set?
    CALL     IncreaseVolume ; else IncreaseVolume
    BTFSS    Port,DEC      ; if DEC is high, fail
    CALL     DecreaseVolume ; else DecreaseVolume
    BCF      INTCON, RBIF  ; clear port interrupt
    RETFIE   ; return from interrupt

```

```

;*****
;
;*
;* Routine - Increase Volume
;* Input - none
;* Output - RVol
;* If RVol>0x00 increment RVol and update
;*****
IncreaseVolume
    MOVF    RVol,0           ; move RVol to W
    SUBLW   0x00            ; W = 0x00 - RVol
    BTFSS   STATUS,ZERO     ; if zero bit is set, don't decrement
    DECF    RVol           ; else decrement
    CALL    UpdateRVol     ; Update RVol
    RETURN

;*****
;*
;* Routine - Decrease Volume
;* Input - none
;* Output - RVol
;* If RVol<0x1f increment RVol and update
;*****
DecreaseVolume
    MOVF    RVol,0           ; move RVol to W
    SUBLW   0x1f            ; W = 0x1f - RVol
    BTFSS   STATUS,ZERO     ; if zero bit is set, don't increment
    INCF    RVol           ; else increment
    CALL    UpdateRVol     ; Update RVol
    RETURN

;*****
;*
;* Routine - Update RVol
;* Input - Move RVol to Reg0Hi:Reg0Lo
;* Output - Reg0Hi,Reg0Lo
;* This routine takes RVol and updates Reg0 with the values
;*****
UpdateRVol
    BCF     Reg0Hi,1
    BCF     Reg0Hi,0
    BCF     Reg0Lo,7
    BCF     Reg0Lo,6
    BCF     Reg0Lo,5           ; set RVol area in Reg0 to 0s
    BTFSC   RVol,4
    BSF     Reg0Hi,1           ; set appropriate bit to 1 as needed
    BTFSC   RVol,3
    BSF     Reg0Hi,0
    BTFSC   RVol,2
    BSF     Reg0Lo,7
    BTFSC   RVol,1
    BSF     Reg0Lo,6
    BTFSC   RVol,0
    BSF     Reg0Lo,5
    MOVF    Reg0Hi,0         ; move Reg0Hi to W
    MOVWF   RegHi           ; move W to RegHi
    MOVF    Reg0Lo,0        ; move Reg0Lo to W
    MOVWF   RegLo          ; move W to RegLo
    CALL    WriteReg
    RETURN

```

```

;*****
;
;*
;* Routine - WriteReg (keeps /RST hi)
;* Input - Word to be sent is in RegHi:RegLo
;* Output - none
;* This routine calls SendData twice with the real data and adds the dummy writes
;*****
WriteReg
    BCF        PORTA,STROBE    ; set STROBE lo
    BCF        PORTA,DRDY     ; set DRDY lo
    MOVF       RegHi,0        ; move RegHi to W
    MOVWF     Temp           ; move W to Temp
    CALL       SendData       ; bit-bang 8 bits (most-significant)
    MOVF       RegLo,0        ; move RegLo to W
    MOVWF     Temp           ; move W to Temp
    CALL       SendData       ; bit-band 8 bits (least-significant)
    BSF        PORTA,DRDY     ; signal end of transaction
    MOVLW     #0x04          ; NOW send four dummy clocks to latch data
    MOVWF     Count          ; initialize Count to 4
LOOP4   BCF        PORTA,DATAIN ; set DATAIN lo
        BSF        PORTA,STROBE ; toggle STROBE (4 extra STROBE pulses)
        BCF        PORTA,STROBE
        DECFSZ    Count        ; decrement counter
        GOTO      LOOP4        ; loop 4 times
        RETURN          ; return from subroutine
;*****
;*
;* Routine - SendData (keeps /DRDY lo and /RST hi)
;* Input - Byte to be transmitted is passed in Temp
;* Output - none
;* This routine sends 1 byte to the CS6420 MCR
;*****
SendData
    MOVLW     #0x08
    MOVWF     Count          ; initialize Count to 8
LOOP8   RLF        Temp,1      ; rotate byte left one
        BTFSZ    STATUS,CARRY  ; if carry bit = 1,
        BSF        PORTA,DATAIN ; set DATAIN hi
        BTFSZ    STATUS,CARRY  ; if carry bit = 0,
        BCF        PORTA,DATAIN ; set DATAIN lo
        BSF        PORTA,STROBE ; clock data in
        BCF        PORTA,STROBE
        DECFSZ    Count,1      ; decrement counter
        GOTO      LOOP8        ; loop 8 times
        BCF        PORTA,DATAIN ; set DATAIN high
        RETURN
;*****
;*
;* Routine - Delay
;* Input - none
;* Output - none
;* This routine is a software delay
;*****
Delay
DelayLoop CLRF        DelayTime    ; implement when needed
          MOVLW     0x34          ; Count 100 or 0x34
          MOVWF     DelayMore
Delay2   DECFSZ    DelayMore,1    ; loop 100 times
          GOTO      Delay2
          DECFSZ    DelayTime,1   ; loop 255 times
          GOTO      DelayLoop
          RETURN
end

```

• **Notes** •

SMART
Analog™



LittleDiode supplies new, hard to find or obsolete electronic components and semiconductors all over the world.

With over two million different components listed you are sure to find the part you need.

Feel free to visit us today at our online store:

LittleDiode.com

Looking forward to providing you with the best possible service.