

RF & MICROWAVE TRANSISTORS S-BAND RADAR APPLICATIONS

- REFRACTORY/GOLD METALLIZATION
- EMITTER SITE BALLASTED
- 5:1 VSWR CAPABILITY
- LOW THERMAL RESISTANCE
- INPUT/OUTPUT MATCHING
- OVERLAY GEOMETRY
- METAL/CERAMIC HERMETIC PACKAGE
- P_{OUT} = 5.0 W MIN. WITH 5.2 dB GAIN

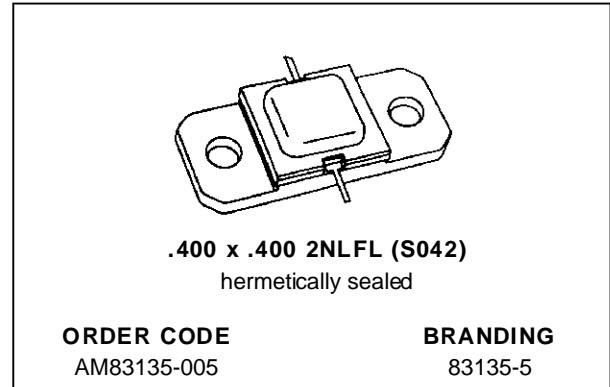

DESCRIPTION

The AM83135-005 device is a medium power silicon bipolar NPN transistor specifically designed for S-Band radar pulsed driver applications.

This device is capable of operation over a wide range of pulse widths, duty cycles and temperatures, and can withstand a 5:1 output VSWR. Low RF thermal resistance, refractory/gold metallization, and computerized automatic wire bonding techniques ensure high reliability and product consistency.

The AM83135-005 is supplied in the AMPAC™ Hermetic Metal/Ceramic package with internal Input/Output matching circuitry, and is intended for military and other high reliability applications.

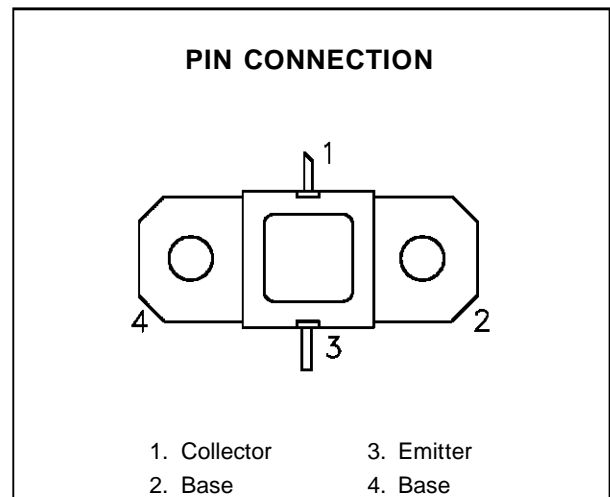

ABSOLUTE MAXIMUM RATINGS (T_{case} = 25°C)

Symbol	Parameter	Value	Unit
P _{DISS}	Power Dissipation* (T _c ≤ 100°C)	40	W
I _c	Device Current*	1.8	A
V _{CC}	Collector-Supply Voltage*	34	V
T _J	Junction Temperature (Pulsed RF Operation)	250	°C
T _{STG}	Storage Temperature	- 65 to +200	°C

THERMAL DATA

R _{TH(j-c)}	Junction-Case Thermal Resistance*	3.75	°C/W
----------------------	-----------------------------------	------	------

*Applies only to rated RF amplifier operation

ELECTRICAL SPECIFICATIONS ($T_{\text{case}} = 25^{\circ}\text{C}$)

STATIC

Symbol	Test Conditions			Value			Unit
				Min.	Typ.	Max.	
BV_{CBO}	$I_{\text{C}} = 4 \text{ mA}$	$I_{\text{E}} = 0 \text{ mA}$		50	—	—	V
BV_{EBO}	$I_{\text{E}} = 2 \text{ mA}$	$I_{\text{C}} = 0 \text{ mA}$		3.5	—	—	V
BV_{CER}	$I_{\text{C}} = 4 \text{ mA}$	$R_{\text{BE}} = 10 \Omega$		50	—	—	V
I_{CES}	$V_{\text{CE}} = 30 \text{ V}$			—	—	2.0	mA
h_{FE}	$V_{\text{CE}} = 5 \text{ V}$	$I_{\text{C}} = 500 \text{ mA}$		10	—	—	—

DYNAMIC

Symbol	Test Conditions			Value			Unit
				Min.	Typ.	Max.	
P_{OUT}	$f = 3.1 - 3.5 \text{ GHz}$	$P_{\text{IN}} = 1.5 \text{ W}$	$V_{\text{CC}} = 30 \text{ V}$	5.0	6.0	—	W
h_{c}	$f = 3.1 - 3.5 \text{ GHz}$	$P_{\text{OUT}} = 5.0 \text{ W}$	$V_{\text{CC}} = 30 \text{ V}$	27	—	—	%
P_{G}	$f = 3.1 - 3.5 \text{ GHz}$	$P_{\text{OUT}} = 5.0 \text{ W}$	$V_{\text{CC}} = 30 \text{ V}$	5.2	6.4	—	dB

Note: Pulse Width = $100 \mu\text{S}$
Duty Cycle = 10%

IMPEDANCE DATA

TYPICAL INPUT IMPEDANCE

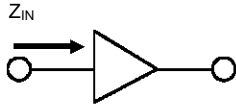

TYPICAL COLLECTOR LOAD IMPEDANCE

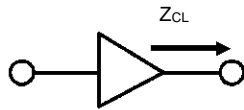

FREQ.	Z _{IN} (Ω)	Z _{CL} (Ω)
L = 2.7 GHz	9.0 + j 22.0	48.0 + j 11.5
ù = 2.9 GHz	9.0 + j 23.0	43.0 + j 9.0
M = 3.1 GHz	12.5 + j 25.0	30.0 + j 3.0
ù = 3.3 GHz	20.0 + j 25.0	21.5 + 0.0
H = 3.5 GHz	22.0 + j 22.5	16.0 - j 3.0

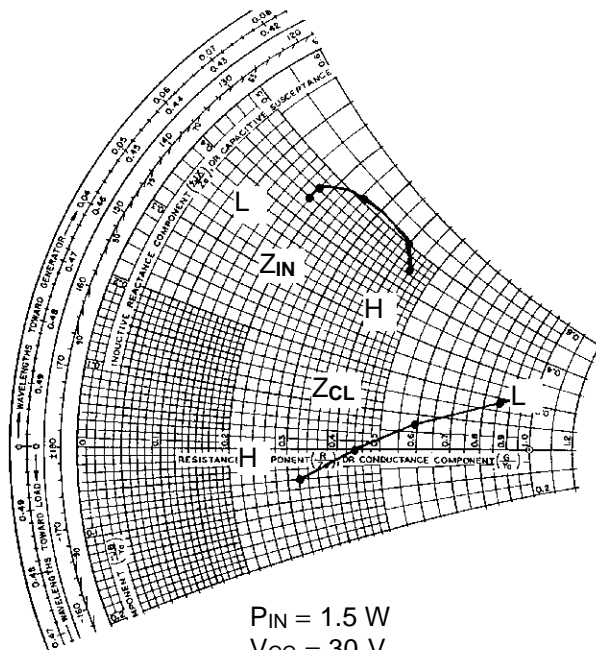

P_{IN} = 1.5 W
 V_{CC} = 30 V
 Normalized to 50 ohms

TEST CIRCUIT

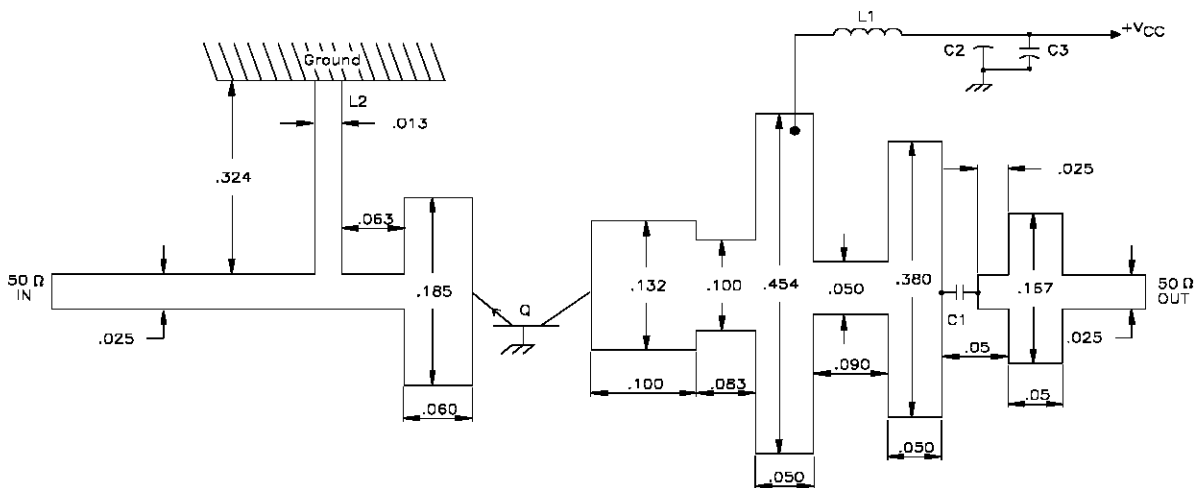

All dimensions are in inches.
 Substrate Material: .025 tick Al₂O₃ (Er = 9.6)

- C1 : 100 pF Chip Capacitor (Note: Mounted on its thin side)
- C2 : 1500 pF RF Feedthru
- C3 : 100 mF Electrolytic
- L1 : No. 32 Wire, 2 Turns 1/16" I.D.
- L2 : Printed Choke

PACKAGE MECHANICAL DATA

Ref.: Dwg. No. 12-0213 rev. A
UDCS Doc. No. 1011416

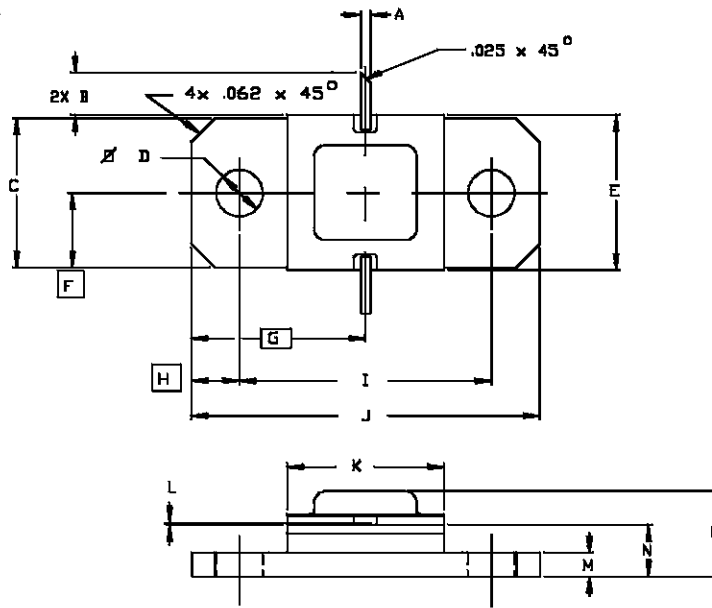

SGS-THOMSON MICROELECTRONICS		CONT'D			
	MINIMUM Inches/mm	MAXIMUM Inches/mm		MINIMUM Inches/mm	MAXIMUM Inches/mm
A	.020/0,51	.030/0,76	K	.395/10,03	.415/10,54
B	.100/2,54		L	.004/0,10	.006/0,18
C	.376/9,53	.396/10,06	M	.052/1,32	.072/1,83
D	.110/2,79	.130/3,30	N	.118/3,00	.131/3,33
E	.395/10,03	.407/10,34	P		.230/5,84
F	.193/4,90				
G	.450/11,43				
H	.125/3,18				
I	.640/16,26	.660/16,76			
J	.890/22,61	.910/23,11			

Information furnished is believed to be accurate and reliable. However, SGS-THOMSON Microelectronics assumes no responsibility for the consequences of use of such information nor for any infringement of patents or other rights of third parties which may result from its use. No license is granted by implication or otherwise under any patent or patent rights of SGS-THOMSON Microelectronics. Specifications mentioned in this publication are subject to change without notice. This publication supersedes and replaces all information previously supplied. SGS-THOMSON Microelectronics products are not authorized for use as critical components in life support devices or systems without express written approval of SGS-THOMSON Microelectronics.

©1996 SGS-THOMSON Microelectronics - All Rights Reserved

SGS-THOMSON Microelectronics GROUP OF COMPANIES
Australia - Brazil - France - Germany - Hong Kong - Italy - Japan - Korea - Malaysia -



LittleDiode supplies new, hard to find or obsolete electronic components and semiconductors all over the world.

With over two million different components listed you are sure to find the part you need.

Feel free to visit us today at our online store:

LittleDiode.com

Looking forward to providing you with the best possible service.