

RF & MICROWAVE TRANSISTORS S-BAND RADAR APPLICATIONS

- LOW PARASITIC, DOUBLE LEVEL MET-AL DESIGN
- REFRACTORY/GOLD METALLIZATION
- EMITTER SITE BALLASTED
- 3:1 VSWR @ 1 dB OVERDRIVE
- LOW RF THERMAL RESISTANCE
- INPUT/OUTPUT IMPEDANCE MATCHING
- OVERLAY GEOMETRY
- METAL/CERAMIC HERMETIC PACKAGE
- P_{OUT} = 25 W MIN. WITH 6.2 dB GAIN

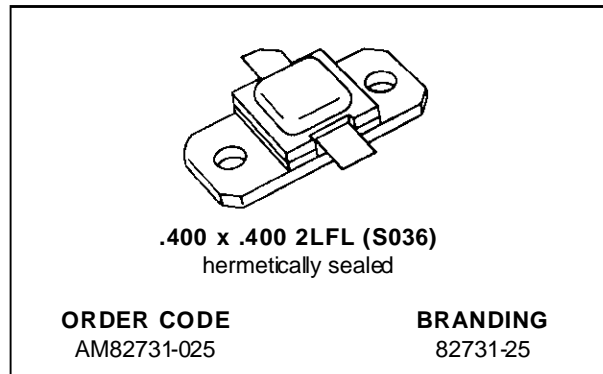

DESCRIPTION

The AM82731-025 device is a high power silicon bipolar NPN transistor specifically designed for S-Band radar pulsed output and driver applications.

This device is capable of operation over a wide range of pulse widths, duty cycles, and temperatures and can withstand a 3:1 output VSWR with a +1dB input over drive. Low RF thermal resistance, refractory/gold metallization, and automatic wire bonding techniques ensure high reliability and product consistency (including phase characteristics).

The AM82731-025 is supplied in the Hermetic Metal/Ceramic package with internal Input/Output impedance matching circuitry, and is intended for military and other high reliability applications.

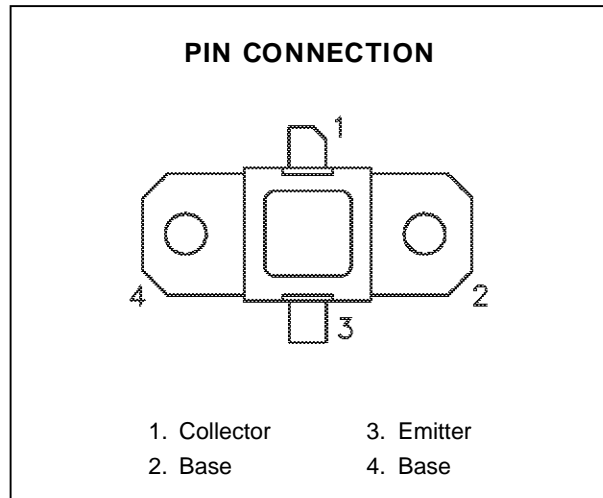

ABSOLUTE MAXIMUM RATINGS (T_{case} = 25°C)

Symbol	Parameter	Value	Unit
P _{DISS}	Power Dissipation* (T _C ≤ 50°C)	100	W
I _C	Device Current*	4	A
V _{CC}	Collector-Supply Voltage*	46	V
T _J	Junction Temperature (Pulsed RF Operation)	250	°C
T _{STG}	Storage Temperature	- 65 to +200	°C

THERMAL DATA

R _{TH(j-c)}	Junction-Case Thermal Resistance*	2.0	°C/W
----------------------	-----------------------------------	-----	------

*Applies only to rated RF amplifier operation

ELECTRICAL SPECIFICATIONS ($T_{case} = 25^{\circ}C$)

STATIC

Symbol	Test Conditions		Value			Unit
			Min.	Typ.	Max.	
BV_{CBO}	$I_C = 15mA$	$I_E = 0mA$	55	—	—	V
BV_{EBO}	$I_E = 2mA$	$I_C = 0mA$	3.5	—	—	V
BV_{CER}	$I_C = 15mA$	$R_{BE} = 10\Omega$	55	—	—	V
I_{CES}	$V_{CE} = 0V$	$V_{BE} = 40V$	—	—	10	mA
h_{FE}	$V_{CE} = 5V$	$I_C = 1.5A$	30	—	—	—

DYNAMIC

Symbol	Test Conditions			Value			Unit
				Min.	Typ.	Max.	
P_{OUT}	$f = 2.7 - 3.1GHz$	$P_{IN} = 6.0W$	$V_{CC} = 40V$	25	30	—	W
η_C	$f = 2.7 - 3.1GHz$	$P_{IN} = 6.0W$	$V_{CC} = 40V$	30	36	—	%
G_{PB}	$f = 2.7 - 3.1GHz$	$P_{IN} = 6.0W$	$V_{CC} = 40V$	6.2	7.0	—	dB

Note: Pulse Width = 100 μ Sec
 Duty Cycle = 10%

TYPICAL PERFORMANCE

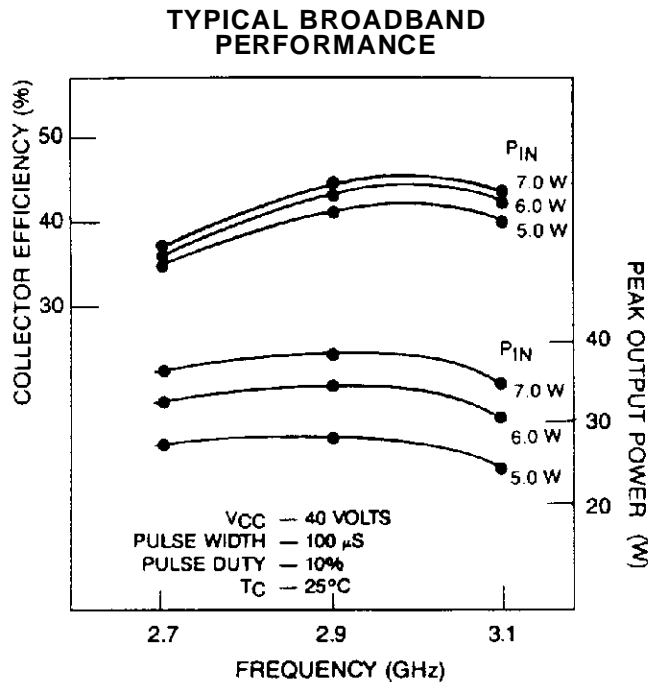

IMPEDANCE DATA

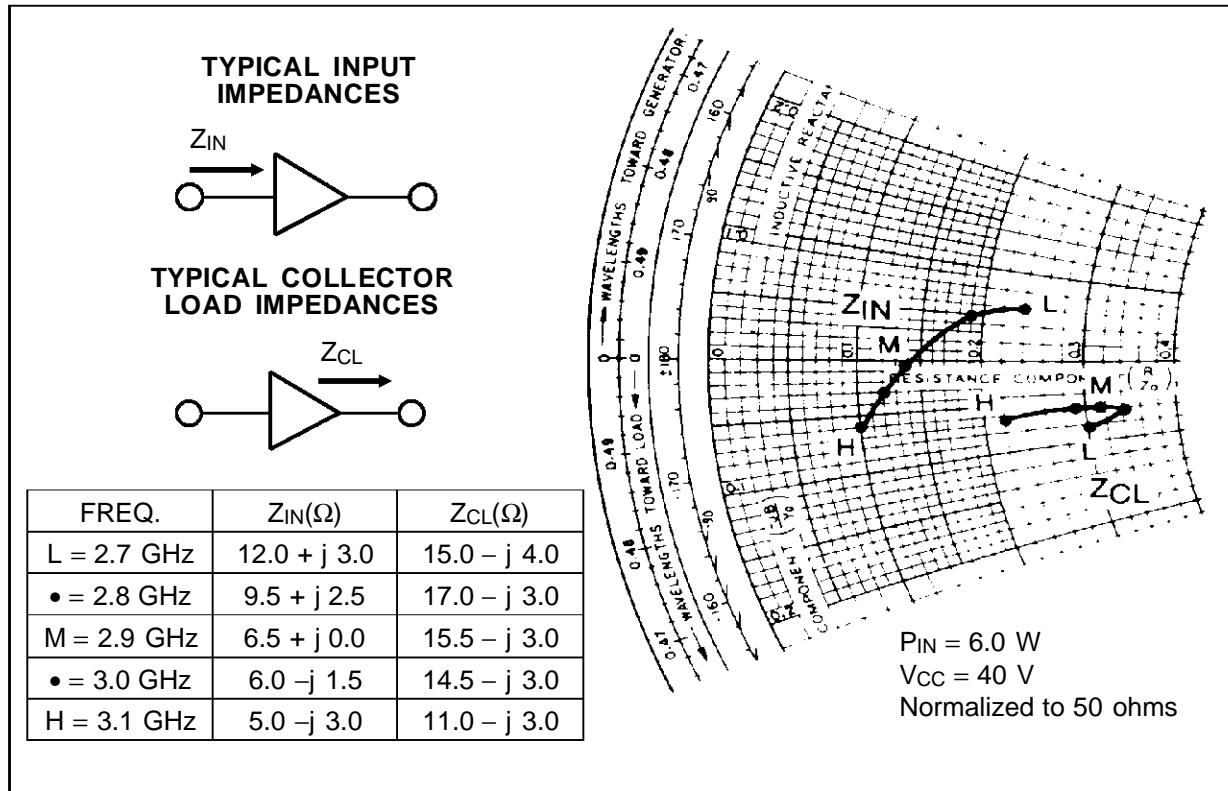

TEST CIRCUIT

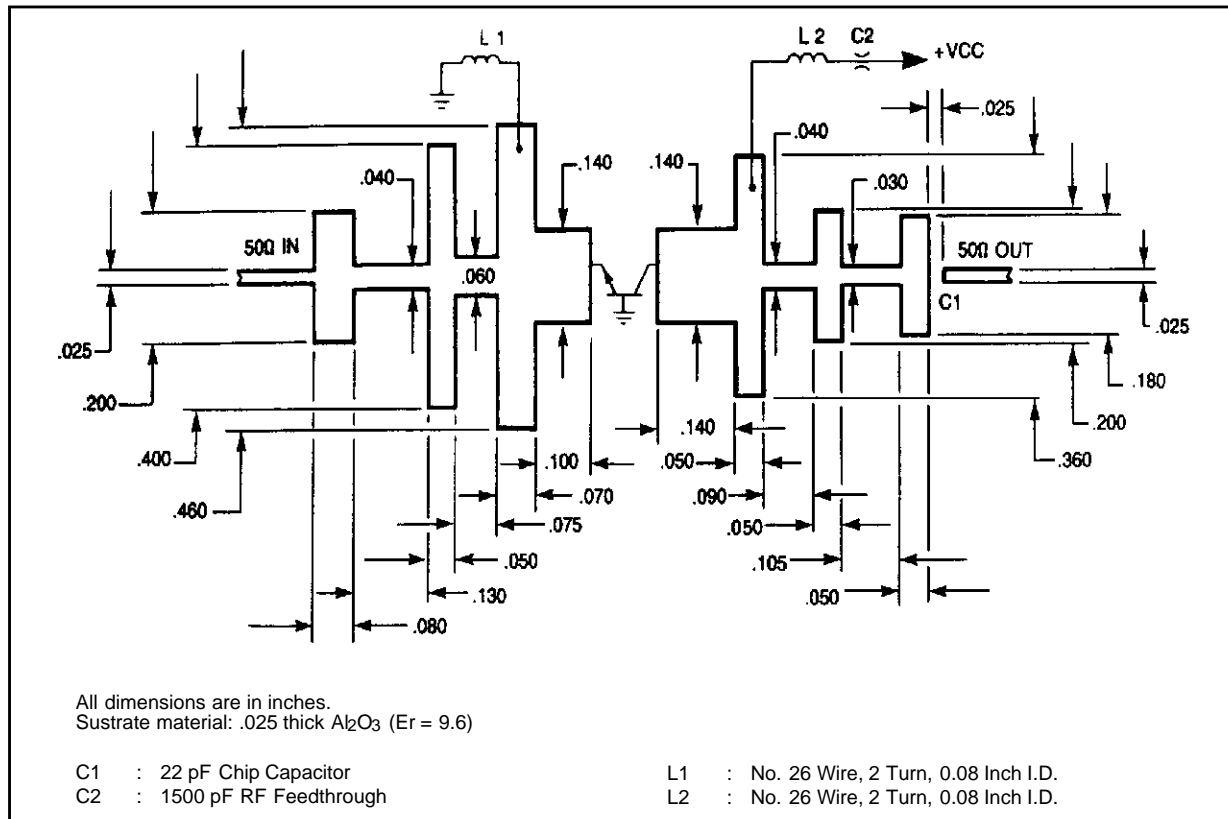

PACKAGE MECHANICAL DATA

Ref.: Dwg. No.: J133102E

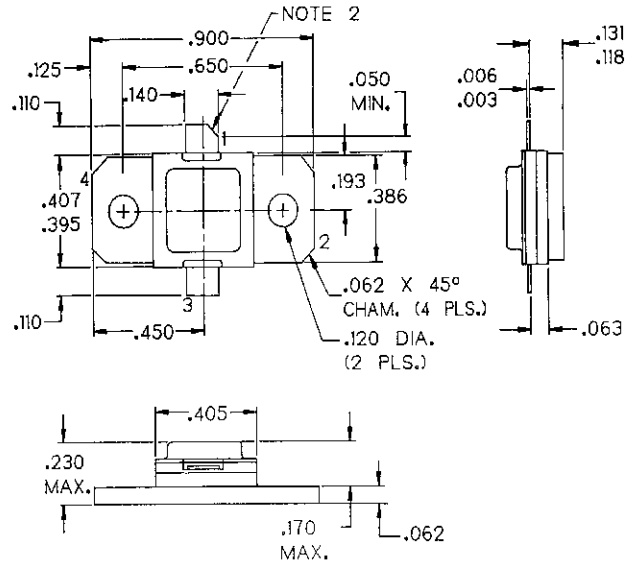

NOTES:

1. ALL TOLERANCE $\pm .010$ EXCEPT WHERE NOTED;
DIMENSIONS IN INCHES.
2. COLLECTOR LEAD CHAMFER 45° NOM. X .040 NOM.

Information furnished is believed to be accurate and reliable. However, SGS-THOMSON Microelectronics assumes no responsibility for the consequences of use of such information nor for any infringement of patents or other rights of third parties which may results from its use. No license is granted by implication or otherwise under any patent or patent rights of SGS-THOMSON Microelectronics. Specifications mentioned in this publication are subject to change without notice. This publication supersedes and replaces all information previously supplied. SGS-THOMSON Microelectronics products are not authorized for use as critical components in life support devices or systems without express written approval of SGS-THOMSON Microelectronics.

© 1994 SGS-THOMSON Microelectronics - All Rights Reserved

SGS-THOMSON Microelectronics GROUP OF COMPANIES
Australia - Brazil - France - Germany - Hong Kong - Italy - Japan - Korea - Malaysia - Malta - Morocco - The Netherlands - Singapore - Spain - Sweden - Switzerland - Taiwan - Thailand - United Kingdom - U.S.A

This datasheet has been downloaded from:

www.DatasheetCatalog.com

Datasheets for electronic components.



LittleDiode supplies new, hard to find or obsolete electronic components and semiconductors all over the world.

With over two million different components listed you are sure to find the part you need.

Feel free to visit us today at our online store:

LittleDiode.com

Looking forward to providing you with the best possible service.