

## RF & MICROWAVE TRANSISTORS TELEMETRY APPLICATIONS

PRELIMINARY DATA

- REFRACTORY/GOLD METALLIZATION
- EMITTER SITE BALLASTED
- LOW THERMAL RESISTANCE
- INPUT/OUTPUT MATCHING
- OVERLAY GEOMETRY
- METAL/CERAMIC HERMETIC PACKAGE
- P<sub>OUT</sub> = 28 W MIN. WITH 6.7 dB GAIN

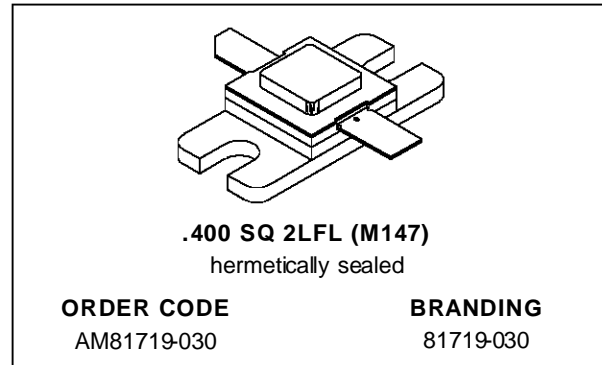

### DESCRIPTION

The AM81719-030 is a high power silicon NPN bipolar transistor designed for Class C, CW communications and telemetry applications in the 1.75 - 1.85 GHz frequency range.

An emitter site ballasted refractory/gold overlay die geometry computerized automatic wire bonding is employed to ensure long term reliability and product consistency.

AM81719-030 is supplied in the industry-standard AMPAC™ hermetic metal/ceramic package.

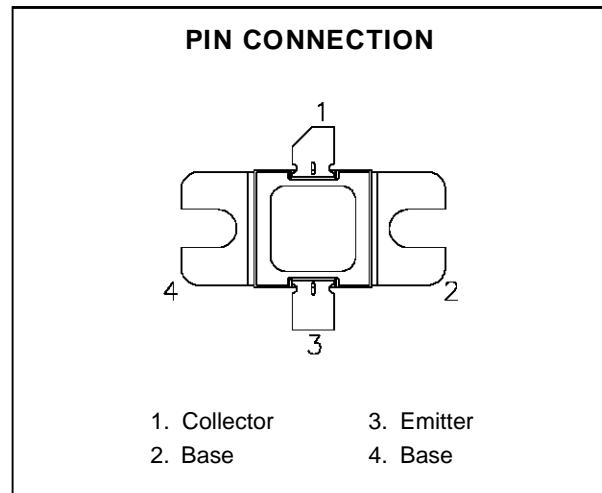

### ABSOLUTE MAXIMUM RATINGS (T<sub>case</sub> = 25°C)

Symbol	Parameter	Value	Unit
P <sub>DISS</sub>	Power Dissipation*	67.3	W
I <sub>C</sub>	Device Current*	2.67	A
V <sub>CC</sub>	Collector-Supply Voltage*	28	V
T <sub>J</sub>	Junction Temperature	200	°C
T <sub>STG</sub>	Storage Temperature	- 65 to +200	°C

### THERMAL DATA

R <sub>TH(j-c)</sub>	Junction-Case Thermal Resistance*	2.6	°C/W
----------------------	-----------------------------------	-----	------

\*Applies only to rated RF amplifier operation

**ELECTRICAL SPECIFICATIONS** (Tcase = 25°C)

STATIC

Symbol	Test Conditions		Value			Unit
			Min.	Typ.	Max.	
BV <sub>CBO</sub>	I <sub>C</sub> = 10mA	I <sub>E</sub> = 0mA	45	—	—	V
BV <sub>EBO</sub>	I <sub>E</sub> = 10mA	I <sub>C</sub> = 0mA	3.0	—	—	V
BV <sub>CES</sub>	I <sub>C</sub> = 10mA		45	—	—	V
I <sub>CES</sub>	V <sub>BE</sub> = 0V	V <sub>CE</sub> = 28V	—	—	5	mA
h <sub>FE</sub>	V <sub>CE</sub> = 5V	I <sub>C</sub> = 2mA	15	—	150	—

DYNAMIC

Symbol	Test Conditions			Value			Unit
				Min.	Typ.	Max.	
P <sub>OUT</sub>	f = 1.75 — 1.85GHz	P <sub>IN</sub> = 6.0W	V <sub>CC</sub> = 28V	28	—	—	W
η <sub>c</sub>	f = 1.75 — 1.85GHz	P <sub>IN</sub> = 6.0W	V <sub>CC</sub> = 28V	40	—	—	%
G <sub>P</sub>	f = 1.75 — 1.85GHz	P <sub>IN</sub> = 6.0W	V <sub>CC</sub> = 28V	6.7	—	—	dB

TYPICAL PERFORMANCE

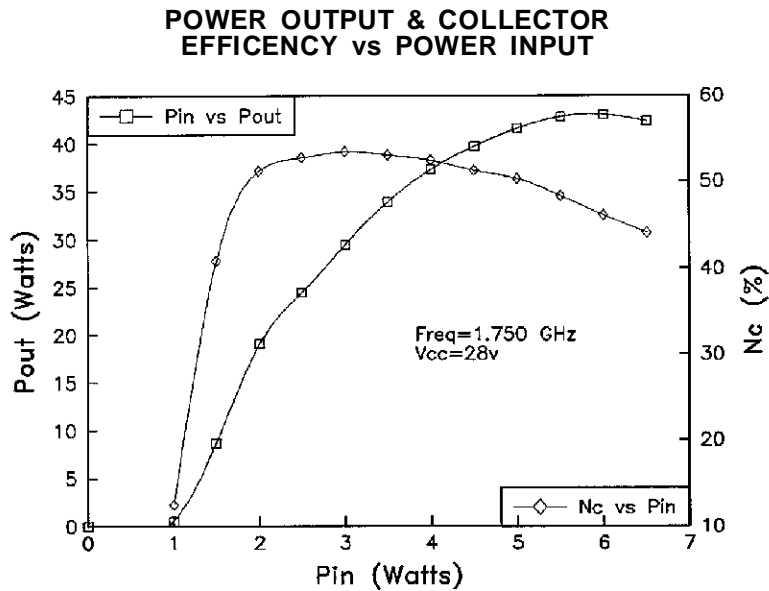

IMPEDANCE DATA

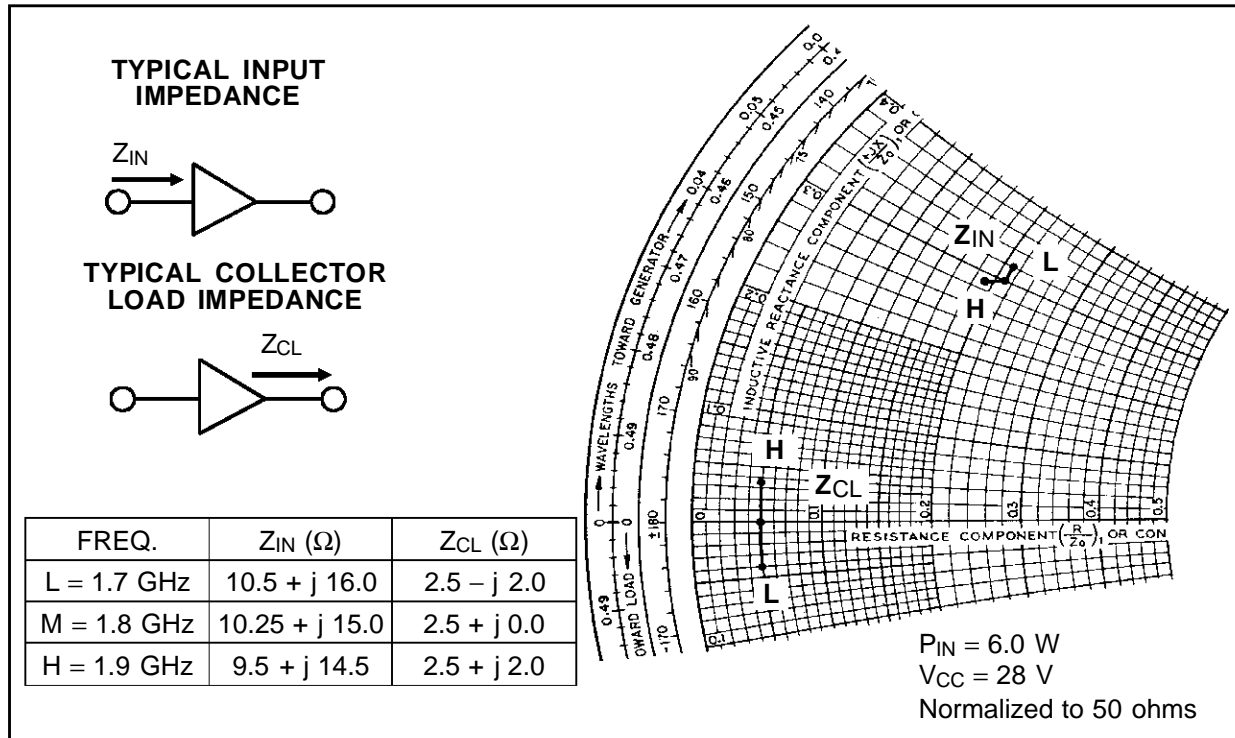

TEST CIRCUIT

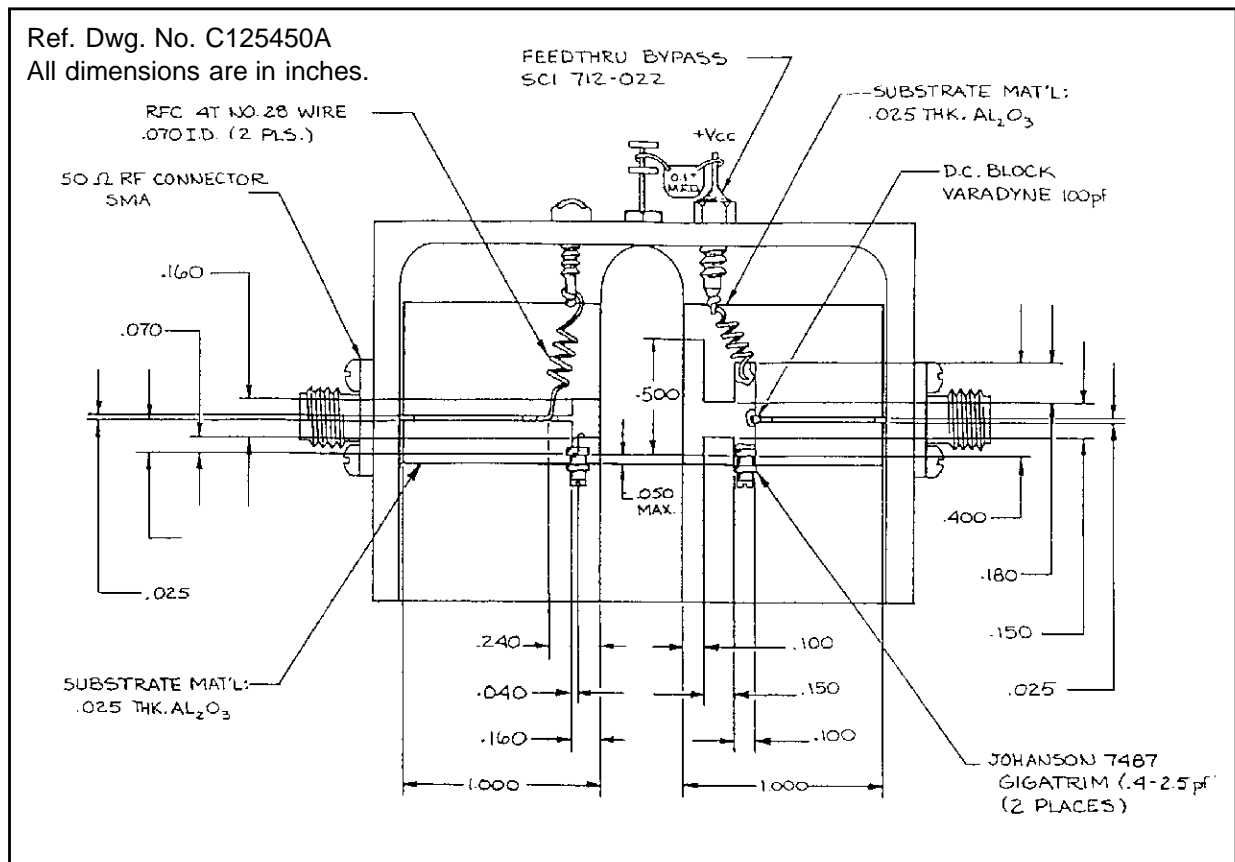

PACKAGE MECHANICAL DATA

Ref.: Dwg. No. 12-0147

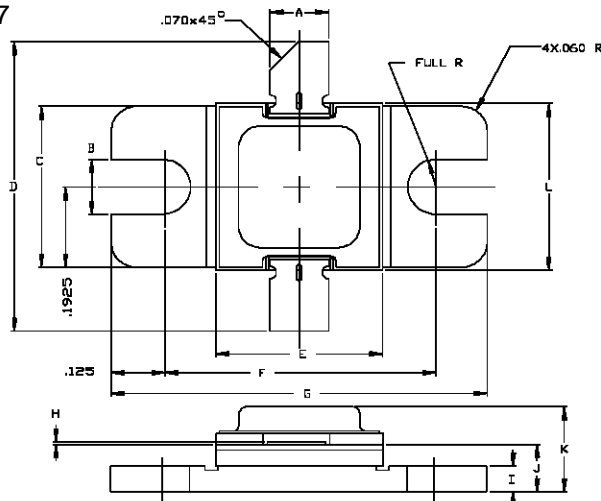

SGS-THOMSON MICROELECTRONICS		CONT'D			
	MINIMUM Inches/mm	MAXIMUM Inches/mm		MINIMUM Inches/mm	MAXIMUM Inches/mm
A	.135/3,43	.145/3,68	K		.230/5,84
B	.125/3,18		L	.392/9,96	.402/10,29
C	.380/9,65	.390/9,91			
D	.885/22,48				
E	.392/9,96	.402/10,29			
F	.645/16,38	.655/16,64			
G	.895/22,73	.905/22,99			
H	.002/0,05	.006/0,15			
I	.055/1,40	.065/1,65			
J	.105/2,67	.125/3,18			

Information furnished is believed to be accurate and reliable. However, SGS-THOMSON Microelectronics assumes no responsibility for the consequences of use of such information nor for any infringement of patents or other rights of third parties which may results from its use. No license is granted by implication or otherwise under any patent or patent rights of SGS-THOMSON Microelectronics. Specifications mentioned in this publication are subject to change without notice. This publication supersedes and replaces all information previously supplied. SGS-THOMSON Microelectronics products are not authorized for use as critical components in life support devices or systems without express written approval of SGS-THOMSON Microelectronics.

© 1994 SGS-THOMSON Microelectronics - All Rights Reserved

SGS-THOMSON Microelectronics GROUP OF COMPANIES  
 Australia - Brazil - France - Germany - Hong Kong - Italy - Japan - Korea - Malaysia - Malta - Morocco - The Netherlands -  
 Singapore - Spain - Sweden - Switzerland - Taiwan - Thailand - United Kingdom - U.S.A



LittleDiode supplies new, hard to find or obsolete electronic components and semiconductors all over the world.

With over two million different components listed you are sure to find the part you need.

Feel free to visit us today at our online store:

[LittleDiode.com](http://LittleDiode.com)

Looking forward to providing you with the best possible service.