

## RF & MICROWAVE TRANSISTORS S-BAND RADAR APPLICATIONS

- REFRACTORY/GOLD METALLIZATION
- EMITTER SITE BALLASTED
- LOW THERMAL RESISTANCE
- INPUT/OUTPUT MATCHING
- OVERLAY GEOMETRY
- METAL/CERAMIC HERMETIC PACKAGE
- P<sub>OUT</sub> = 125 W MIN. WITH 7.0 dB GAIN

### DESCRIPTION

The AM2729-125 device is a high power silicon bipolar NPN transistor specifically designed for medium pulse S-Band radar output and driver applications.

This device is characterized at 50 μsec pulse width and 10% duty cycle, but is capable of operation over a range of pulse widths, duty cycles and temperatures. Low RF thermal resistance, refractory/gold metallization and computerized automatic wire bonding techniques ensure high reliability and product consistency (including phase characteristics).

The AM2729-125 is supplied in the BIGPAC™ Hermetic Metal/Ceramic package with internal Input/Output impedance matching circuitry, and is intended for military and other high reliability applications.

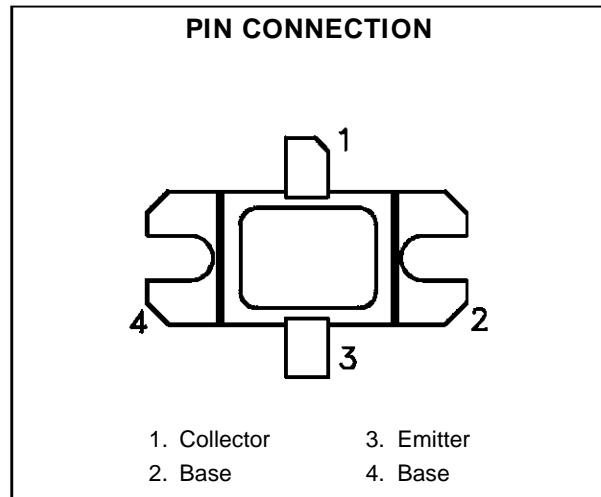
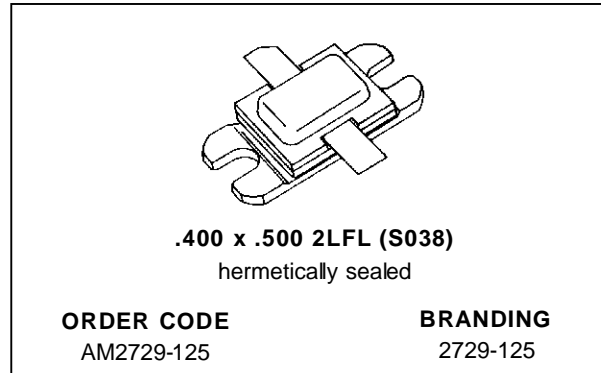

### ABSOLUTE MAXIMUM RATINGS (T<sub>case</sub> = 25°C)

Symbol	Parameter	Value	Unit
P <sub>DISS</sub>	Power Dissipation* (T <sub>c</sub> ≤ 75°C)	500	W
I <sub>c</sub>	Device Current*	16	A
V <sub>CC</sub>	Collector-Supply Voltage*	45	V
T <sub>J</sub>	Junction Temperature (Pulsed RF Operation)	250	°C
T <sub>STG</sub>	Storage Temperature	- 65 to +200	°C

### THERMAL DATA

R <sub>TH(j-c)</sub>	Junction-Case Thermal Resistance*	0.35	°C/W
----------------------	-----------------------------------	------	------

\*Applies only to rated RF amplifier operation

**ELECTRICAL SPECIFICATIONS** ( $T_{case} = 25^{\circ}C$ )

STATIC

Symbol	Test Conditions		Value			Unit
			Min.	Typ.	Max.	
$BV_{CBO}$	$I_C = 50\text{ mA}$	$I_E = 0\text{ mA}$	55	65	—	V
$BV_{EBO}$	$I_E = 10\text{ mA}$	$I_C = 0\text{ mA}$	3.5	4.5	—	V
$BV_{CES}$	$I_C = 50\text{ mA}$	$V_{BE} = 0\text{ V}$	55	65	—	V
$I_{CES}$	$V_{BE} = 0\text{ V}$	$V_{CE} = 40\text{ V}$	—	—	40	mA
$h_{FE}$	$V_{CE} = 5\text{ V}$	$I_C = 5\text{ A}$	30	80	300	—

DYNAMIC

Symbol	Test Conditions			Value			Unit
				Min.	Typ.	Max.	
$P_{OUT}$	$f = 2700 - 2900\text{ MHz}$	$P_{IN} = 25\text{ W}$	$V_{CC} = 40\text{ V}$	125	—	—	W
$\eta_C$	$f = 2700 - 2900\text{ MHz}$	$P_{IN} = 25\text{ W}$	$V_{CC} = 40\text{ V}$	35	—	—	%
GP	$f = 2700 - 2900\text{ MHz}$	$P_{IN} = 25\text{ W}$	$V_{CC} = 40\text{ V}$	7.0	—	—	dB

Note: Pulse Width = 50 $\mu$ Sec  
 Duty Cycle = 10%

**TYPICAL PERFORMANCE**

**TYPICAL BROADBAND EFFICIENCY**

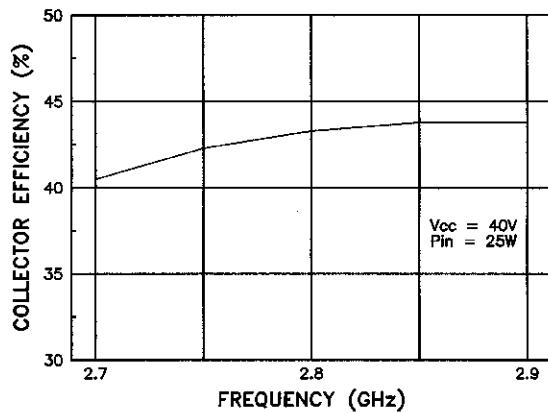

**TYPICAL BROADBAND PERFORMANCE**

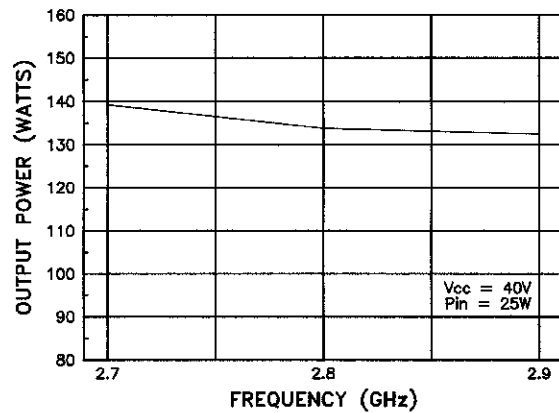

TYPICAL PERFORMANCE (cont'd)

TYPICAL EFFICIENCY @ 2.7 GHz

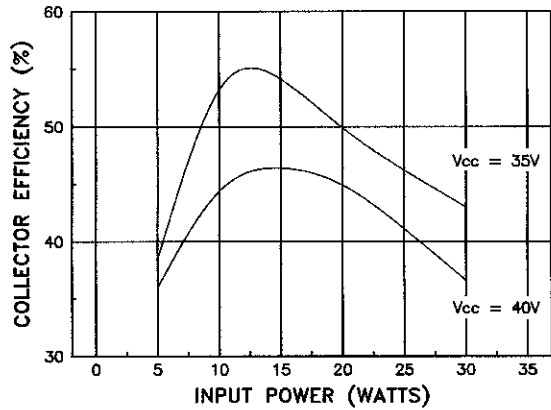

TYPICAL PERFORMANCE @ 2.7 GHz

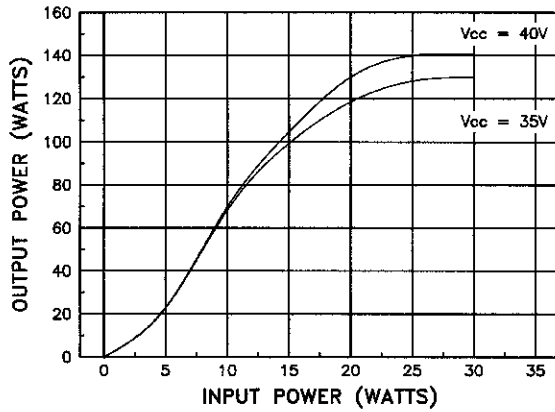

TYPICAL EFFICIENCY @ 2.8 GHz

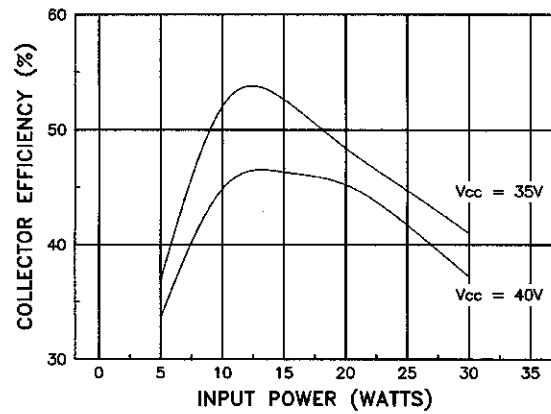

TYPICAL PERFORMANCE @ 2.8 GHz

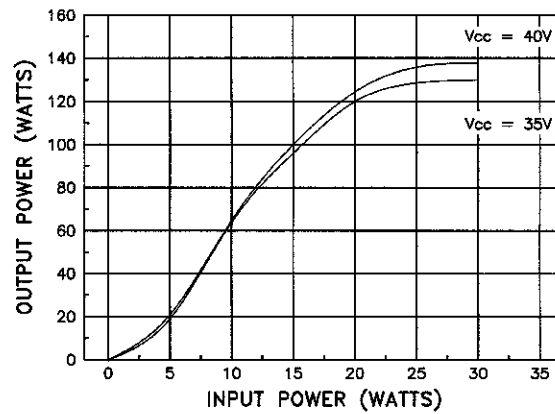

TYPICAL EFFICIENCY @ 2.9 GHz

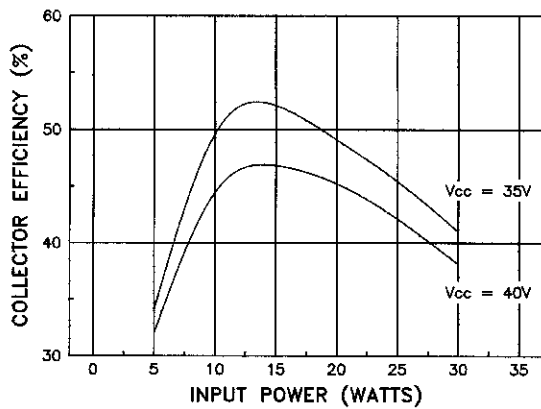

TYPICAL PERFORMANCE @ 2.9 GHz

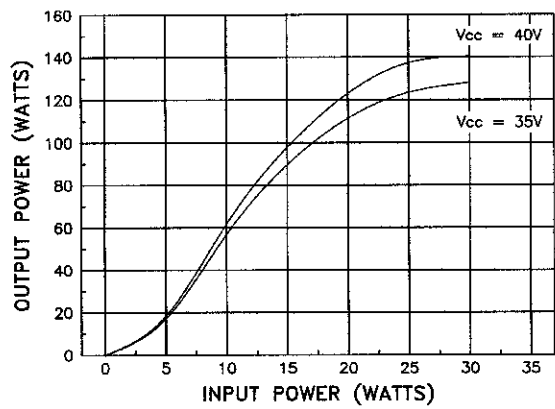

IMPEDANCE DATA

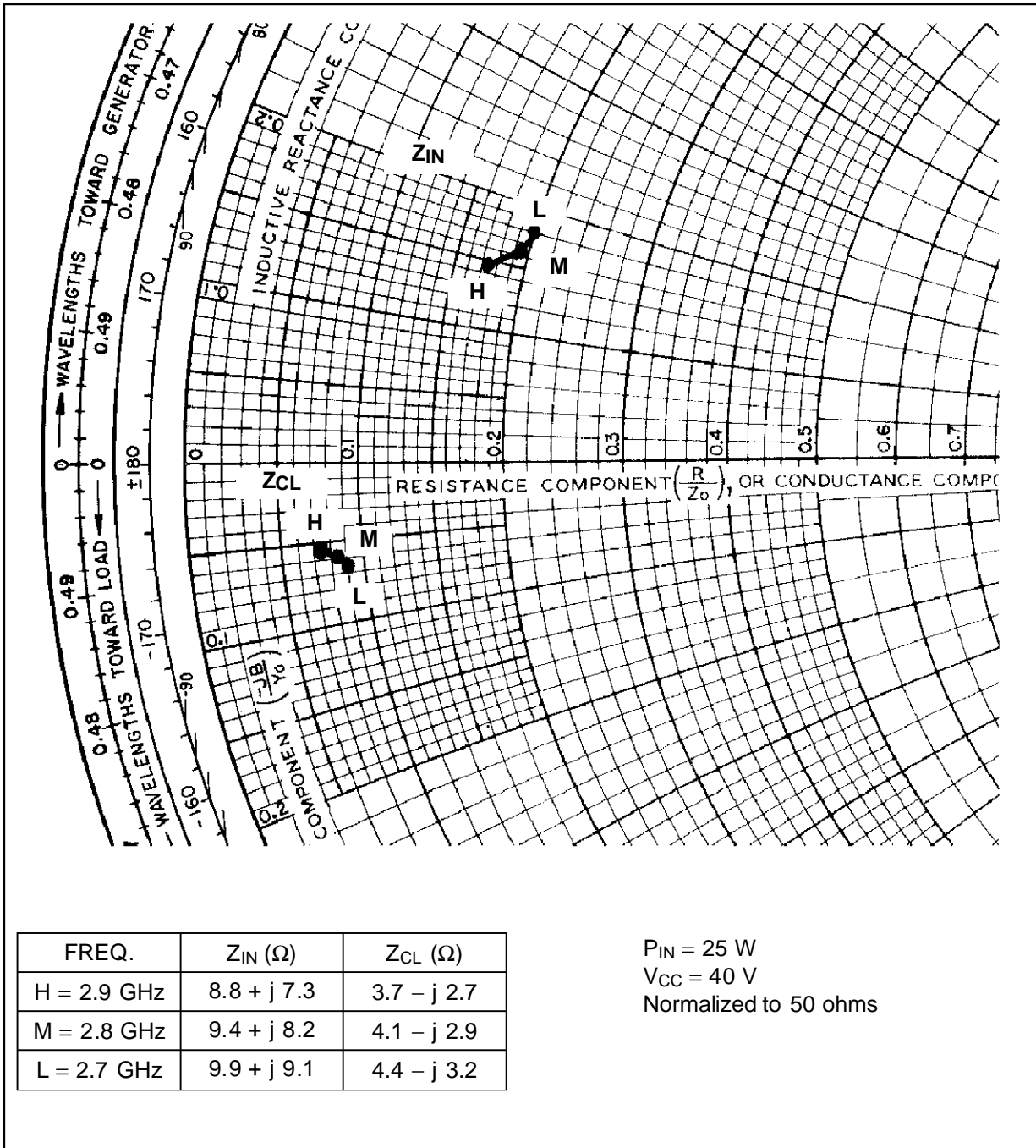

TEST CIRCUIT

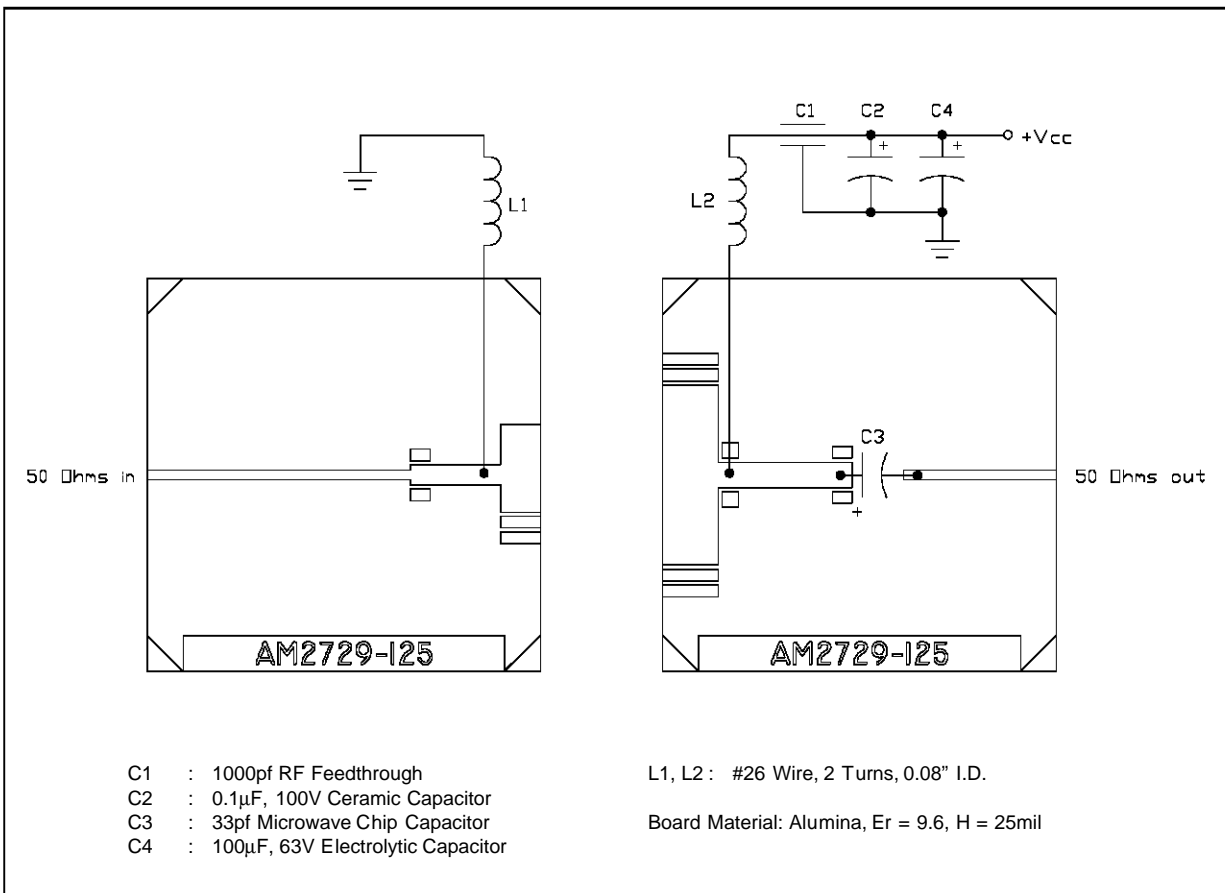
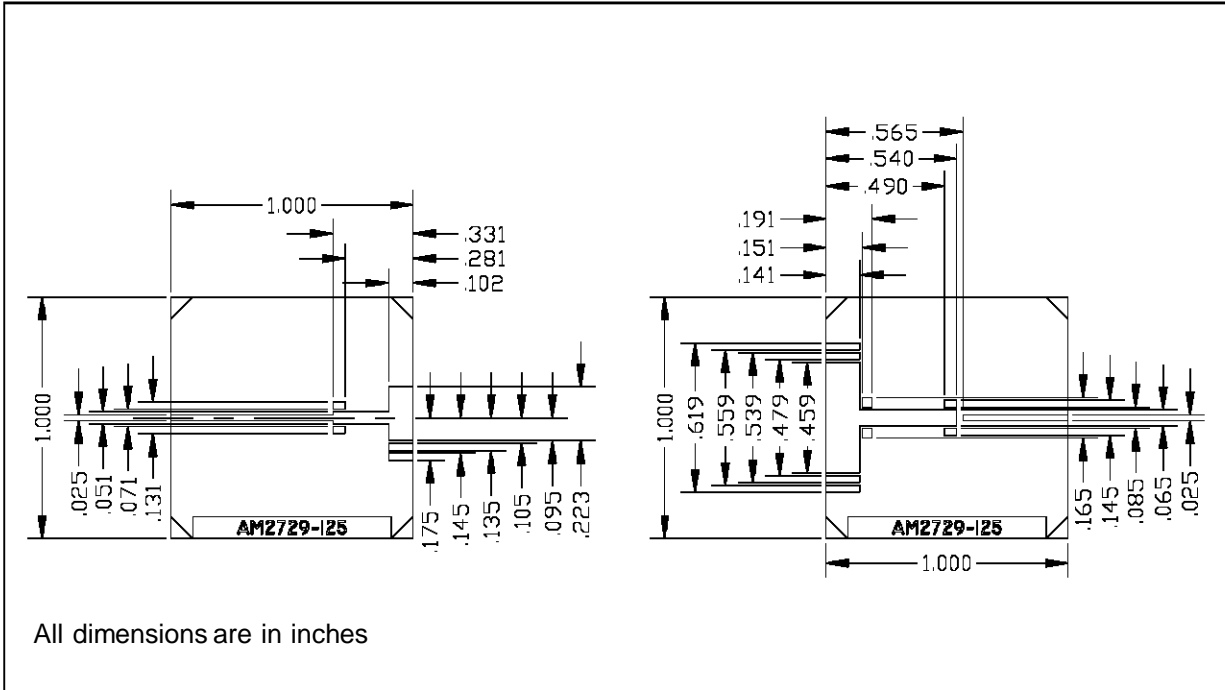

PACKAGE MECHANICAL DATA

Ref.: Dwg. No. 12-0212 rev. A

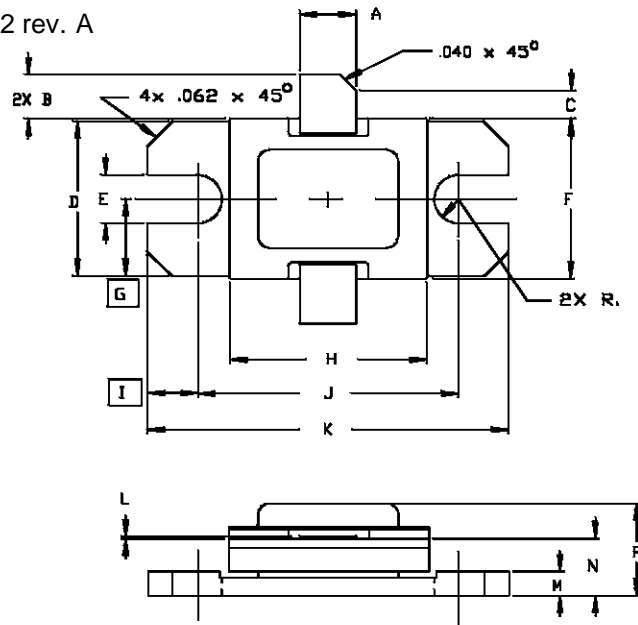

SGS-THOMSON MICROELECTRONICS			CONT'D		
	MINIMUM Inches/mm	MAXIMUM Inches/mm		MINIMUM Inches/mm	MAXIMUM Inches/mm
A	.135/3,43	.145/3,68	K	.890/22,61	.910/23,11
B	.100/2,54	.120/3,05	L	.003/0,08	.006/0,15
C	.050/1,27		M	.052/1,32	.072/1,83
D	.376/9,55	.396/10,06	N	.118/3,00	.131/3,33
E	.110/2,79	.130/3,30	P		.230/5,84
F	.395/10,03	.407/10,34			
G	.193/4,90				
H	.490/12,45	.510/12,95			
I	.100/2,54				
J	.690/17,53	.710/18,03			

Information furnished is believed to be accurate and reliable. However, SGS-THOMSON Microelectronics assumes no responsibility for the consequences of use of such information nor for any infringement of patents or other rights of third parties which may result from its use. No license is granted by implication or otherwise under any patent or patent rights of SGS-THOMSON Microelectronics. Specifications mentioned in this publication are subject to change without notice. This publication supersedes and replaces all information previously supplied. SGS-THOMSON Microelectronics products are not authorized for use as critical components in life support devices or systems without express written approval of SGS-THOMSON Microelectronics.

©1995 SGS-THOMSON Microelectronics - All Rights Reserved

SGS-THOMSON Microelectronics GROUP OF COMPANIES

Australia - Brazil - France - Germany - Hong Kong - Italy - Japan - Korea - Malaysia - Malta - Morocco - The Netherlands - Singapore - Spain - Sweden - Switzerland - Taiwan - Thailand - United Kingdom - U.S.A.

RF Products Group 141 Commerce Drive Montgomeryville, PA 18936 tel 215-361-6400 fax 215-362-1293



LittleDiode supplies new, hard to find or obsolete electronic components and semiconductors all over the world.

With over two million different components listed you are sure to find the part you need.

Feel free to visit us today at our online store:

[LittleDiode.com](http://LittleDiode.com)

Looking forward to providing you with the best possible service.