

RF & MICROWAVE TRANSISTORS L-BAND RADAR APPLICATIONS

- REFRACTORY/GOLD METALLIZATION
- EMITTER SITE BALLASTED
- 5:1 VSWR CAPABILITY
- LOW THERMAL RESISTANCE
- INPUT/OUTPUT MATCHING
- OVERLAY GEOMETRY
- METAL/CERAMIC HERMETIC PACKAGE
- P_{OUT} = 325 W MIN. WITH 6.4 dB GAIN

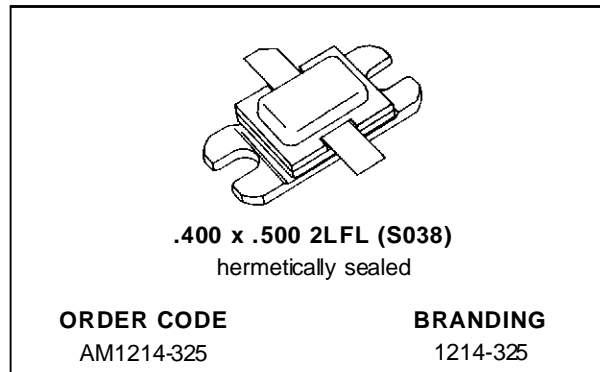

DESCRIPTION

The AM1214-325 device is a high power transistor specifically designed for L-Band radar pulsed output and driver applications.

This device is designed for operation under moderate pulse width and duty cycle conditions and is capable of withstanding 5:1 VSWR at rated RF conditions. Low RF thermal resistance and computerized automatic wire bonding techniques ensure high reliability and product consistency.

The AM1214-325 is supplied in the BIGPAC™ Hermetic Metal/Ceramic package with internal Input/Output matching structures.

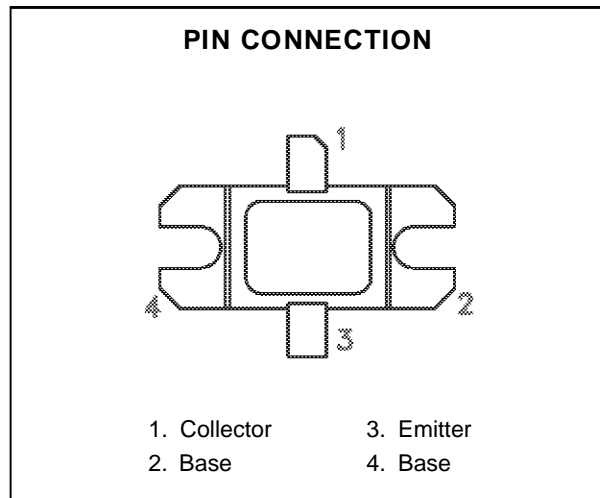

ABSOLUTE MAXIMUM RATINGS (T_{case} = 25°C)

Symbol	Parameter	Value	Unit
P _{DISS}	Power Dissipation* (T _C ≤ 100°C)	1250	W
I _C	Device Current*	25	A
V _{CC}	Collector-Supply Voltage*	45	V
T _J	Junction Temperature (Pulsed RF Operation)	250	°C
T _{STG}	Storage Temperature	- 65 to +200	°C

THERMAL DATA

R _{TH(j-c)}	Junction-Case Thermal Resistance*	0.10	°C/W
----------------------	-----------------------------------	------	------

*Applies only to rated RF amplifier operation

AM1214-325

ELECTRICAL SPECIFICATIONS (T_{case} = 25°C)

STATIC

Symbol	Test Conditions		Value			Unit
			Min.	Typ.	Max.	
BV _{CBO}	I _C = 50mA	I _E = 0mA	65	—	—	V
BV _{EBO}	I _E = 15mA	I _C = 0mA	3.0	—	—	V
BV _{CES}	I _C = 50mA		65	—	—	V
I _{CES}	V _{CE} = 50V		—	—	30	mA
h _{FE}	V _{CE} = 5V	I _C = 5A	10	—	—	—

DYNAMIC

Symbol	Test Conditions			Value			Unit
				Min.	Typ.	Max.	
P _{OUT}	f = 1200 — 1400MHz	P _{IN} = 75W	V _{CC} = 45V	325	360	—	W
η _c	f = 1200 — 1400MHz	P _{IN} = 75W	V _{CC} = 45V	38	45	—	%
G _P	f = 1200 — 1400MHz	P _{IN} = 75W	V _{CC} = 45V	6.4	6.8	—	dB

Note: Pulse Width = 13μSec
Duty Cycle = 2%

TYPICAL PERFORMANCE

POWER OUTPUT & EFFICIENCY
vs FREQUENCY

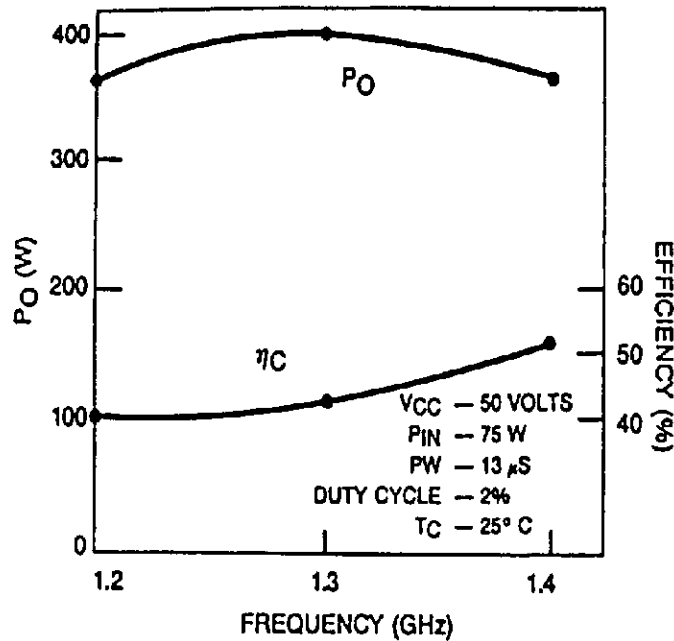

IMPEDANCE DATA

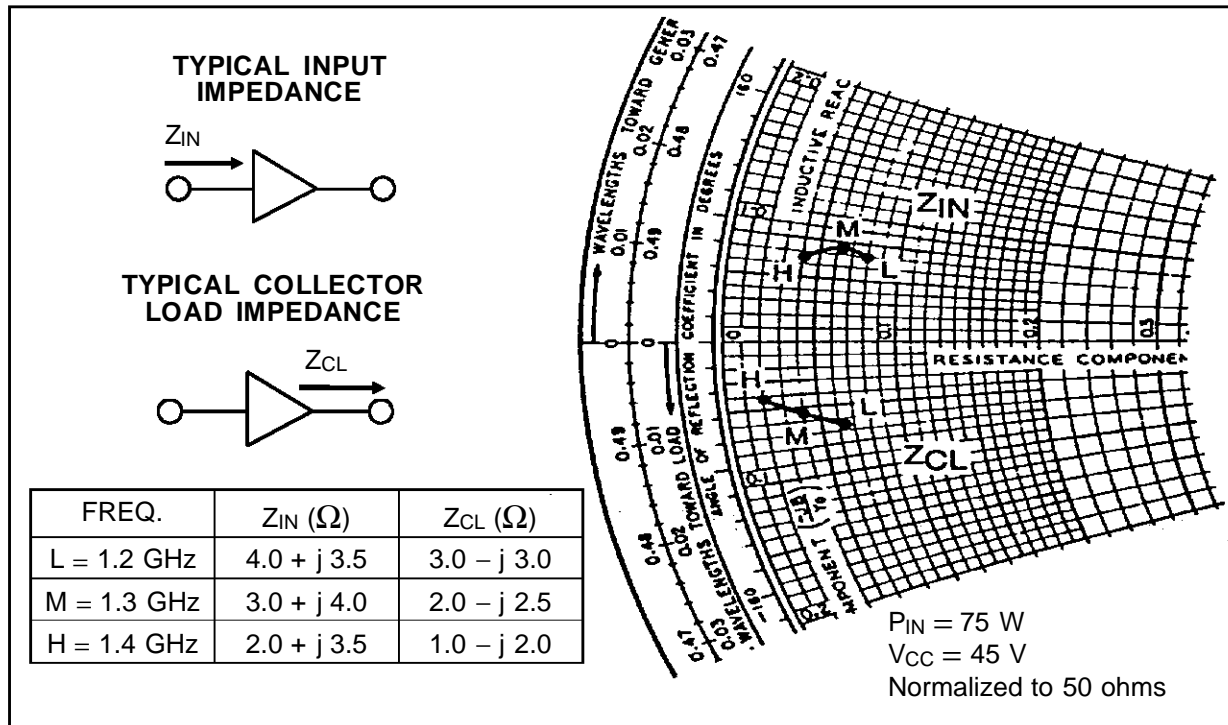

TEST CIRCUIT

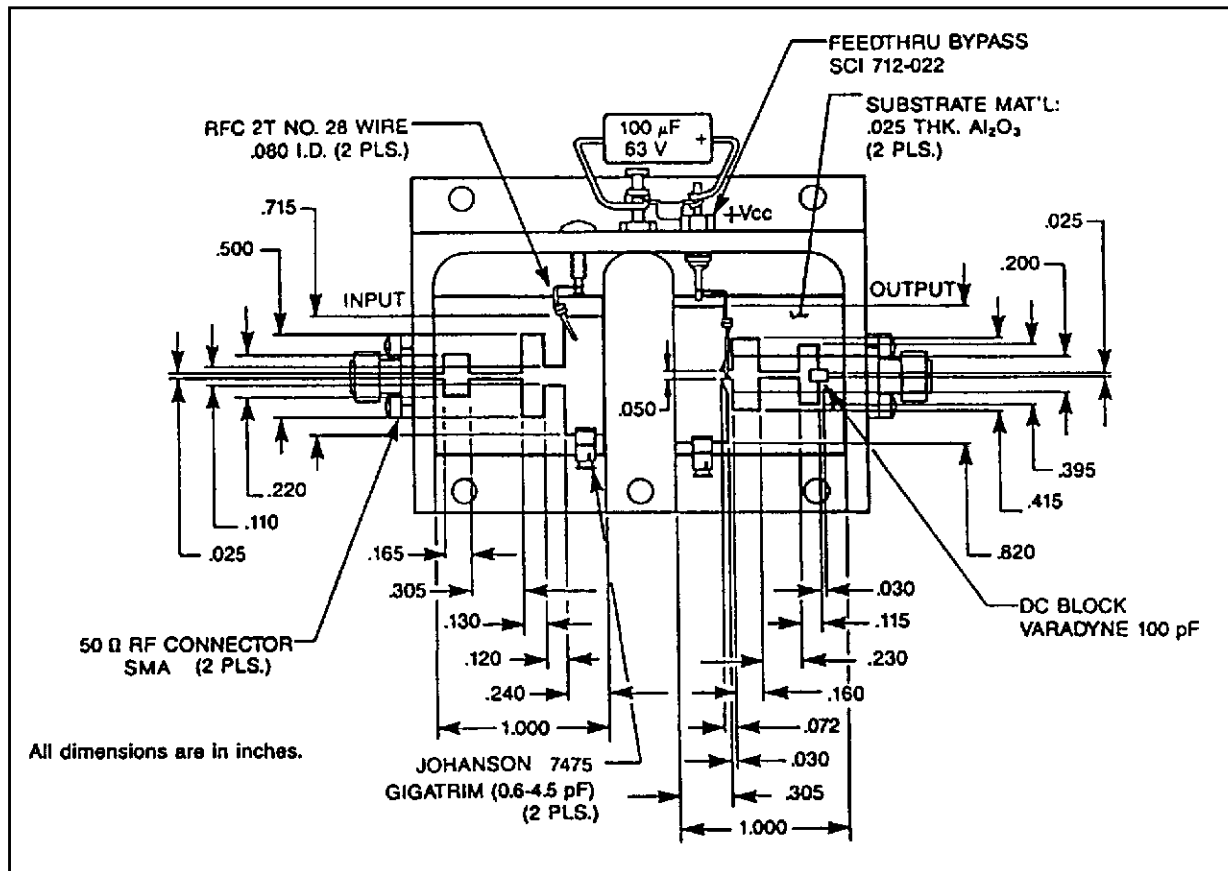

PACKAGE MECHANICAL DATA

Ref.: Dwg. No.: J135066F

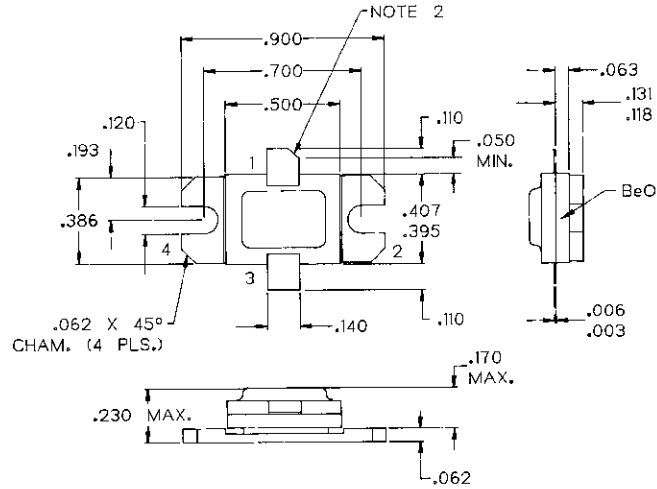

- NOTES:
1. ALL TOLERANCE $\pm .010$ EXCEPT WHERE NOTED;
DIMENSIONS IN INCHES.
2. COLLECTOR LEAD CHAMFER 45° NOM. X $.040$ NOM.

Information furnished is believed to be accurate and reliable. However, SGS-THOMSON Microelectronics assumes no responsibility for the consequences of use of such information nor for any infringement of patents or other rights of third parties which may results from its use. No license is granted by implication or otherwise under any patent or patent rights of SGS-THOMSON Microelectronics. Specifications mentioned in this publication are subject to change without notice. This publication supersedes and replaces all information previously supplied. SGS-THOMSON Microelectronics products are not authorized for use as critical components in life support devices or systems without express written approval of SGS-THOMSON Microelectronics.

© 1994 SGS-THOMSON Microelectronics - All Rights Reserved

SGS-THOMSON Microelectronics GROUP OF COMPANIES
Australia - Brazil - France - Germany - Hong Kong - Italy - Japan - Korea - Malaysia - Malta - Morocco - The Netherlands -
Singapore - Spain - Sweden - Switzerland - Taiwan - Thailand - United Kingdom - U.S.A



LittleDiode supplies new, hard to find or obsolete electronic components and semiconductors all over the world.

With over two million different components listed you are sure to find the part you need.

Feel free to visit us today at our online store:

LittleDiode.com

Looking forward to providing you with the best possible service.