

93L38

8-Bit Multiple Port Register

General Description

The 93L38 is an 8-bit multiple port register designed for high speed random access memory applications where the ability to simultaneously read and write is desirable. A common use would be as a register bank in a three address computer. Data can be written into any one of the eight bits and read from any two of the eight bits simultaneously. The circuit uses TTL technology and is compatible with all TTL families.

Features

- Master/slave operation permitting simultaneous write/read without race problems
- Simultaneously read two bits and write one bit in any one of eight bit positions
- Readily expandable to allow for larger word sizes

Connection Diagram

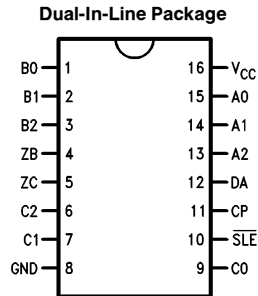

TL/F/10202-1

Order Number 93L38DMQB or 93L38FMQB
See NS Package Number J16A or W16A

Logic Symbol

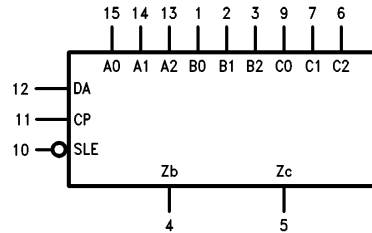

TL/F/10202-2

V_{CC} = Pin 16
 GND = Pin 8

Pin Names	Description
A0-A2	Write Address Inputs
DA	Data Input
B0-B2	B Read Address Inputs
C0-C2	C Read Address Inputs
CP	Clock Pulse Input (Active Rising Edge)
SLE	Slave Enable Input (Active LOW)
ZB	B Output
ZC	C Output

Absolute Maximum Ratings (Note)

If Military/Aerospace specified devices are required, please contact the National Semiconductor Sales Office/Distributors for availability and specifications.

Supply Voltage	7V
Input Voltage	5.5V
Operating Free Air Temperature Range	
Military	–55°C to +125°C
Storage Temperature Range	–65°C to +150°C

Note: The “Absolute Maximum Ratings” are those values beyond which the safety of the device cannot be guaranteed. The device should not be operated at these limits. The parametric values defined in the “Electrical Characteristics” table are not guaranteed at the absolute maximum ratings. The “Recommended Operating Conditions” table will define the conditions for actual device operation.

Recommended Operating Conditions

Symbol	Parameter	93L38 (MIL)			Units
		Min	Nom	Max	
V _{CC}	Supply Voltage	4.5	5	5.5	V
V _{IH}	High Level Input Voltage	2			V
V _{IL}	Low Level Input Voltage			0.7	V
I _{OH}	High Level Output Current			–400	μA
I _{OL}	Low Level Output Current			4.8	mA
T _A	Free Air Operating Temperature	–55		125	°C
t _s (H) t _s (L)	Setup Time HIGH or LOW D _A to CP	30 22			ns
t _h (H) t _h (L)	Hold Time HIGH or LOW D _A to CP	0 –4.0			ns
t _s (H) t _s (L)	Setup Time HIGH or LOW A _n to CP	0 0			ns
t _h (H) t _h (L)	Hold Time HIGH or LOW A _n to CP	0 0			ns
t _w (H) t _w (L)	CP Pulse Width HIGH or LOW	40 30			ns

Electrical Characteristics over recommended operating free air temperature (unless otherwise noted)

Symbol	Parameter	Conditions	Min	Typ (Note 1)	Max	Units
V _I	Input Clamp Voltage	V _{CC} = Min, I _I = –10 mA			–1.5	V
V _{OH}	High Level Output Voltage	V _{CC} = Min, I _{OH} = Max, V _{IL} = Max, V _{IH} = Min	2.4			V
V _{OL}	Low Level Output Voltage	V _{CC} = Min I _{OL} = Max V _{IH} = Min, V _{IL} = Max			0.3	V
I _I	Input Current @ Max Input Voltage	V _{CC} = Max, V _I = 5.5V			1	mA
I _{IH}	High Level Input Current	V _{CC} = Max, V _I = 2.4V			50	μA
I _{IL}	Low Level Input Current	V _{CC} = Max, V _I = 0.3V			–2	mA
I _{OS}	Short Circuit Output Current	V _{CC} = Max (Note 2)	–2.5		–25	mA
I _{CC}	Supply Current	V _{CC} = Max (Note 3)			70	mA

Note 1: All typicals are at V_{CC} = 5V, T_A = 25°C.

Note 2: Not more than one output should be shorted at a time, and the duration should not exceed one second.

Note 3: I_{CC} is measured with all outputs open and all input grounded.

Switching Characteristics $V_{CC} = +5.0V$, $T_A = +25^\circ C$ (See Section 1 for Test Waveforms and Output Load)

Symbol	Parameter	$C_L = 15\text{ pF}$		Units
		Min	Max	
t_{PLH}	Propagation Delay		68	ns
t_{PHL}	B_n or C_n or Z_n		95	
t_{PLH}	Propagation Delay		70	ns
t_{PHL}	D_A to Z_n		92	
t_{PLH}	Propagation Delay		65	ns
t_{PHL}	CP to Z_n		57	

Functional Description

The 93L38 8-bit multiple port register can be considered a 1-bit slice of eight high speed working registers. Data can be written into any one and read from any two of the eight locations simultaneously. Master/slave operation eliminates all race problems associated with simultaneous read/write activity from the same location. When the clock input (CP) is LOW data applied to the data input line (D_A) enters the selected master. This selection is accomplished by coding the three write input select lines (A_0 – A_2) appropriately. Data is stored synchronously with the rising edge of the clock pulse.

The information for each of the two slaved (output) latches is selected by two sets of read address inputs (B_0 – B_2 and C_0 – C_2). The information enters the slave while the clock is HIGH and is stored while the clock is LOW. If Slave Enable is LOW (SLE), the slave latches are continuously enabled.

The signals are available on the output pins (Z_B and Z_C). The input bit selection and the two output bit selections can be accomplished independently or simultaneously. The data flows into the device, is demultiplexed according to the state of the write address lines and is clocked into the selected latch. The eight latches function as masters and store the input data. The two output latches are slaves and hold the data during the read operation. The state of each slave is determined by the state of the master selected by its associated set of read address inputs.

The method of parallel expansion is shown in *Figure A*. One 93L38 is needed for each bit of the required word length. The read and write input lines should be connected in common on all of the devices. This register configuration provides two words of n-bits each at one time, where n devices are connected in parallel.

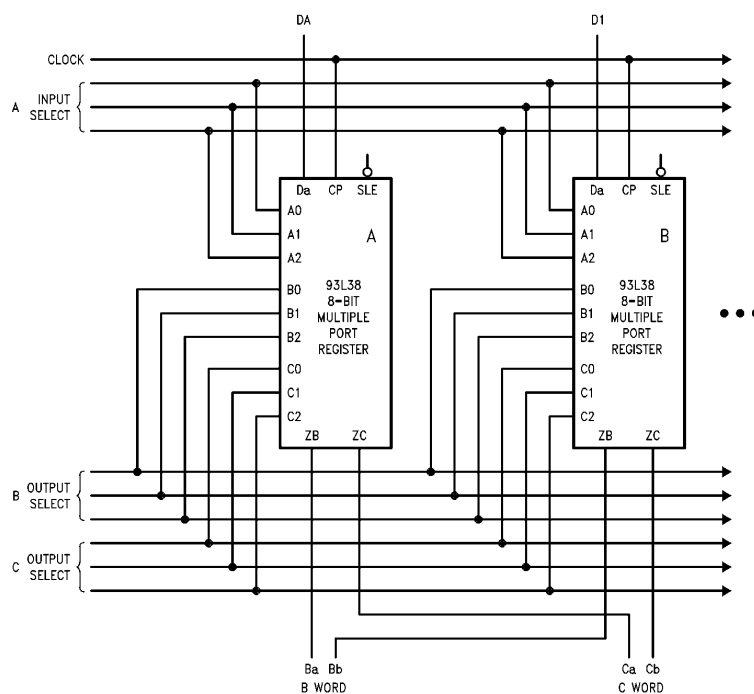
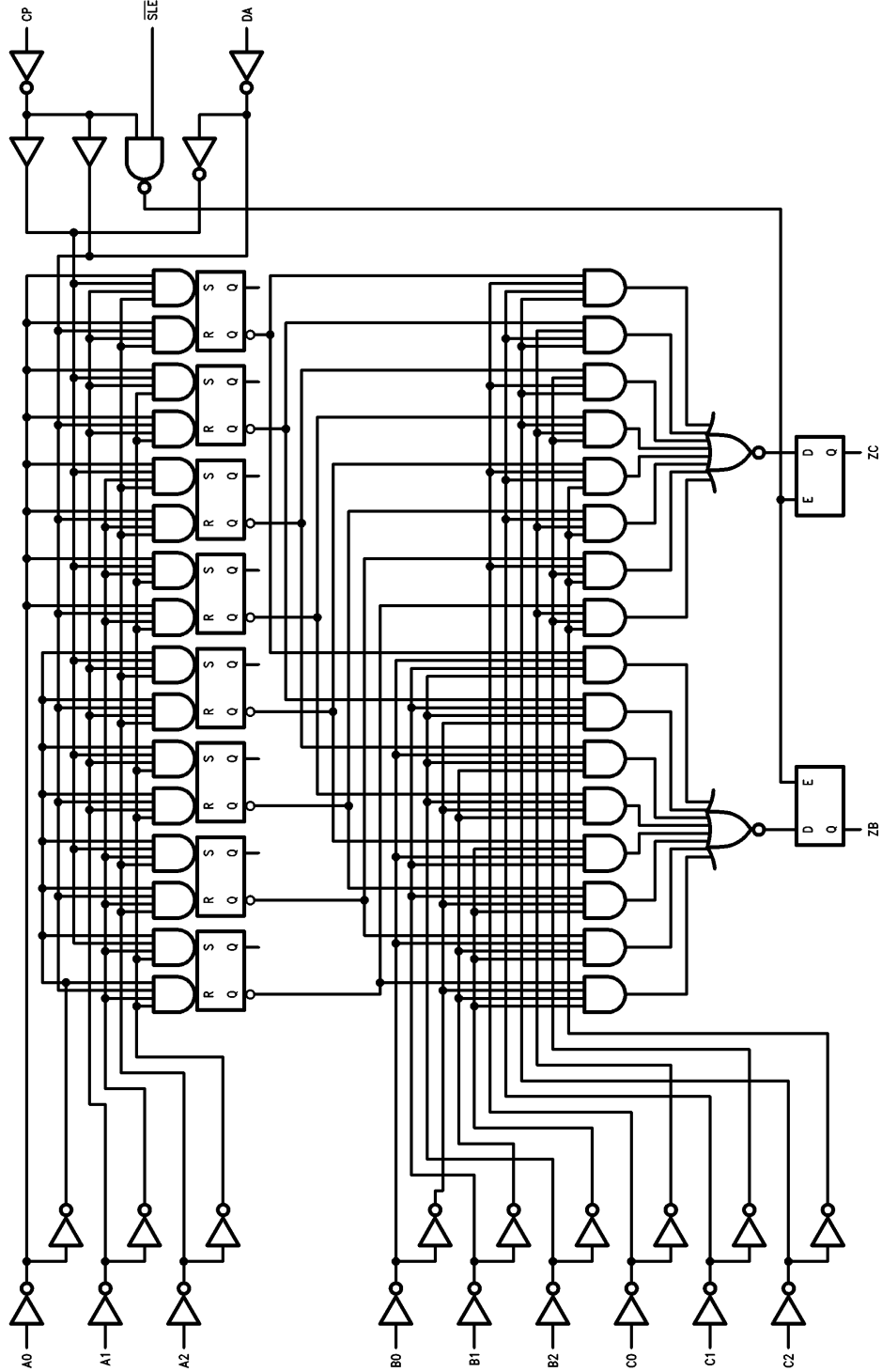

FIGURE A. Parallel Expansion

TL/F/10202-4

Logic Diagram



TL/F/10202--3

Physical Dimensions inches (millimeters)

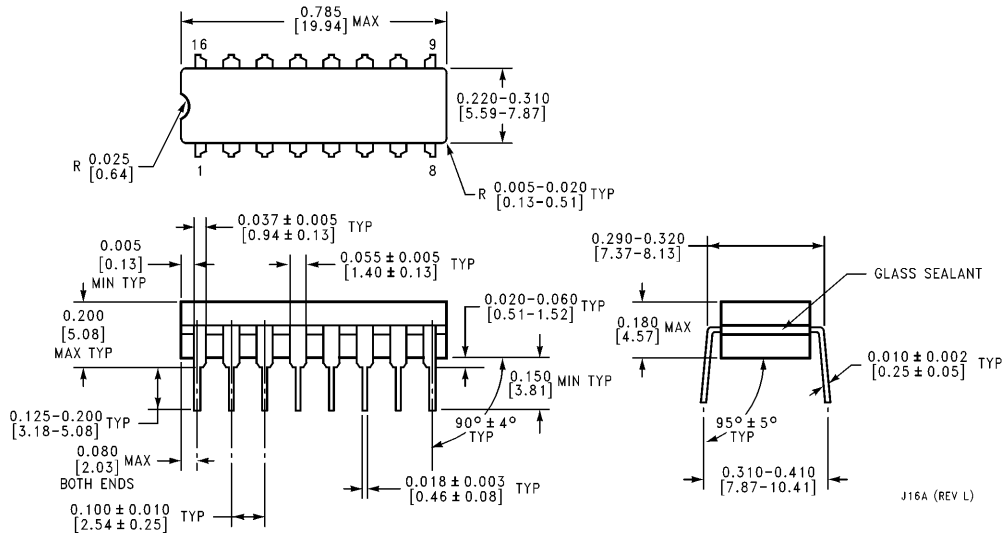

16-Lead Ceramic Dual-In-Line Package (J)
Order Number 93L38DMQB
NS Package Number J16A

J16A (REV L)

Physical Dimensions inches (millimeters) (Continued)

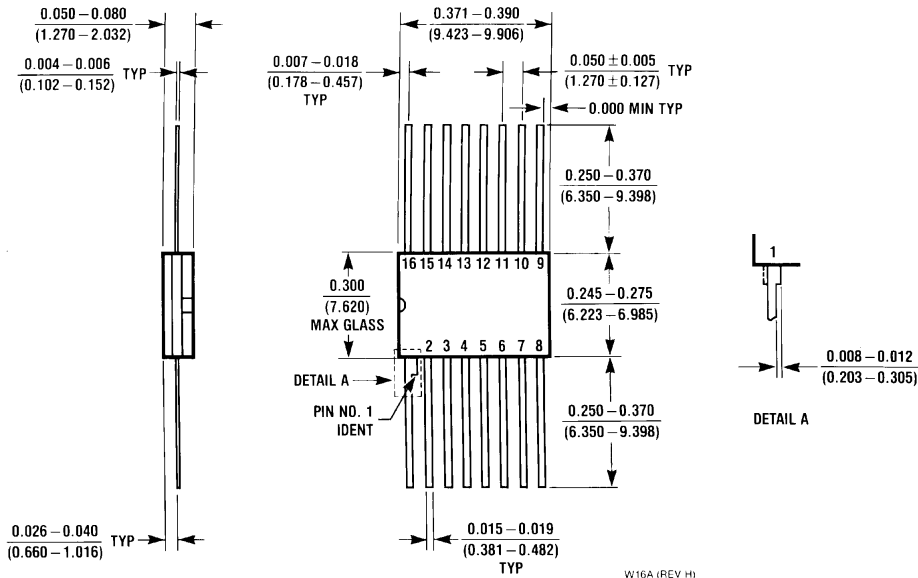

16-Lead Ceramic Flat Package (W)
Order Number 93L38FMQB
NS Package Number W16A

W16A (REV. H)

LIFE SUPPORT POLICY

NATIONAL'S PRODUCTS ARE NOT AUTHORIZED FOR USE AS CRITICAL COMPONENTS IN LIFE SUPPORT DEVICES OR SYSTEMS WITHOUT THE EXPRESS WRITTEN APPROVAL OF THE PRESIDENT OF NATIONAL SEMICONDUCTOR CORPORATION. As used herein:

1. Life support devices or systems are devices or systems which, (a) are intended for surgical implant into the body, or (b) support or sustain life, and whose failure to perform, when properly used in accordance with instructions for use provided in the labeling, can be reasonably expected to result in a significant injury to the user.
2. A critical component is any component of a life support device or system whose failure to perform can be reasonably expected to cause the failure of the life support device or system, or to affect its safety or effectiveness.



National Semiconductor Corporation
 1111 West Bardin Road
 Arlington, TX 76017
 Tel: 1(800) 272-9959
 Fax: 1(800) 737-7018

National Semiconductor Europe
 Fax: (+49) 0-180-530 85 86
 Email: onjwge@tevm2.nsc.com
 Deutsch Tel: (+49) 0-180-530 85 85
 English Tel: (+49) 0-180-532 78 32
 Français Tel: (+49) 0-180-532 93 58
 Italiano Tel: (+49) 0-180-534 16 80

National Semiconductor Hong Kong Ltd.
 19th Floor, Straight Block,
 Ocean Centre, 5 Canton Rd.
 Tsimshatsui, Kowloon
 Hong Kong
 Tel: (852) 2737-1600
 Fax: (852) 2736-9960

National Semiconductor Japan Ltd.
 Tel: 81-043-299-2309
 Fax: 81-043-299-2408

National does not assume any responsibility for use of any circuitry described, no circuit patent licenses are implied and National reserves the right at any time without notice to change said circuitry and specifications.

National Semiconductor was acquired by Texas Instruments.

http://www.ti.com/corp/docs/investor_relations/pr_09_23_2011_national_semiconductor.html

This file is the datasheet for the following electronic components:

93L38 - <http://www.ti.com/product/93L38?HQS=TI-null-null-dscatalog-df-pf-null-ww>



LittleDiode supplies new, hard to find or obsolete electronic components and semiconductors all over the world.

With over two million different components listed you are sure to find the part you need.

Feel free to visit us today at our online store:

LittleDiode.com

Looking forward to providing you with the best possible service.