

DATA SHEET

For a complete data sheet, please also download:

- The IC06 74HC/HCT/HCU/HCMOS Logic Family Specifications
- The IC06 74HC/HCT/HCU/HCMOS Logic Package Information
- The IC06 74HC/HCT/HCU/HCMOS Logic Package Outlines

74HC/HCT7540

Octal Schmitt trigger buffer/line driver; 3-state; inverting

Product specification
Supersedes data of March 1988
File under Integrated Circuits, IC06

December 1990

Octal Schmitt trigger buffer/line driver; 3-state; inverting

74HC/HCT7540

FEATURES

- Inverting outputs
- Schmitt trigger action on all data inputs
- Output capability: bus driver
- I_{CC} category: MSI

GENERAL DESCRIPTION

The 74HC/HCT7540 are high-speed Si-gate CMOS devices and are pin compatible with low power Schottky TTL (LSTTL). They are specified in compliance with JEDEC standard no. 7A.

The 74HC/HCT7540 are octal Schmitt trigger inverting buffer/line drivers with 3-state outputs. The 3-state outputs are controlled by the output enable inputs \overline{OE}_1 and \overline{OE}_2 .

A HIGH on \overline{OE}_n causes the outputs to assume a high impedance OFF-state.

The Schmitt trigger action in the data inputs transforms slowly changing input signals into sharply defined jitter-free output signals.

The "7540" is identical to the "540" but has hysteresis on the data inputs.

QUICK REFERENCE DATA

GND = 0 V; T_{amb} = 25 °C; t_r = t_f = 6 ns

SYMBOL	PARAMETER	CONDITIONS	TYPICAL		UNIT
			HC	HCT	
t _{PHL} / t _{PLH}	propagation delay A _n to \overline{Y}_n	C _L = 15 pF; V _{CC} = 5 V	11	16	ns
C _I	input capacitance		3.5	3.5	pF
C _{PD}	power dissipation capacitance per buffer	notes 1 and 2	29	31	pF

Notes

1. C_{PD} is used to determine the dynamic power dissipation (P_D in μW):

$$P_D = C_{PD} \times V_{CC}^2 \times f_i + \sum (C_L \times V_{CC}^2 \times f_o) \text{ where:}$$

f_i = input frequency in MHz

f_o = output frequency in MHz

∑ (C_L × V_{CC}² × f_o) = sum of outputs

C_L = output load capacitance in pF

V_{CC} = supply voltage in V

2. For HC the condition is V_I = GND to V_{CC}

For HCT the condition is V_I = GND to V_{CC} – 1.5 V

ORDERING INFORMATION

See "74HC/HCT/HCU/HCMOS Logic Package Information".

Octal Schmitt trigger buffer/line driver;
3-state; inverting

74HC/HCT7540

PIN DESCRIPTION

PIN NO.	SYMBOL	NAME AND FUNCTION
1, 19	$\overline{OE}_1, \overline{OE}_2$	output enable inputs (active LOW)
2, 3, 4, 5, 6, 7, 8, 9	A ₀ to A ₇	data inputs
10	GND	ground (0 V)
18, 17, 16, 15, 14, 13, 12, 11	\overline{Y}_0 to \overline{Y}_7	bus outputs
20	V _{CC}	positive supply voltage

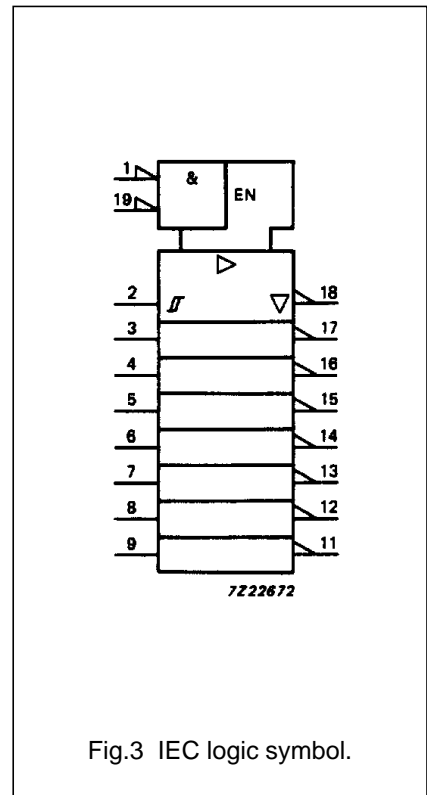
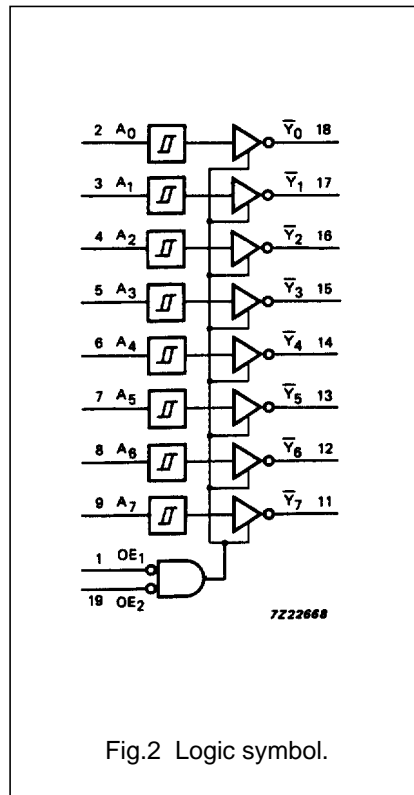
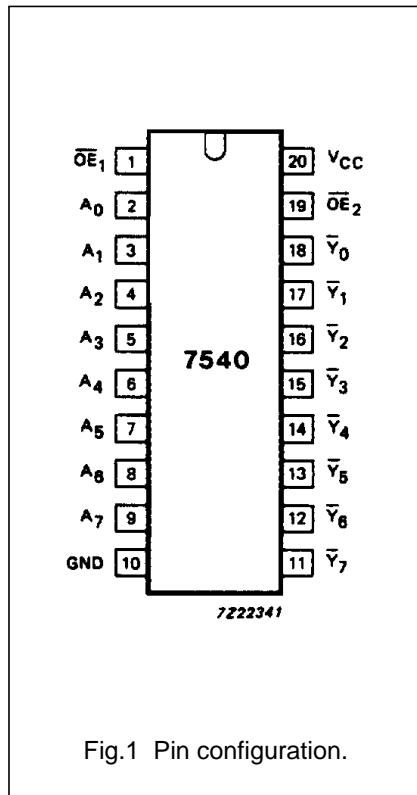

Octal Schmitt trigger buffer/line driver;
3-state; inverting

74HC/HCT7540

FUNCTION TABLE

INPUTS			OUTPUTS
\overline{OE}_1	\overline{OE}_2	A_n	\overline{Y}_n
L	L	L	H
L	L	H	L
X	H	X	Z
H	X	X	Z

Notes

- H = HIGH voltage level
L = LOW voltage level
X = don't care
Z = high impedance OFF-state

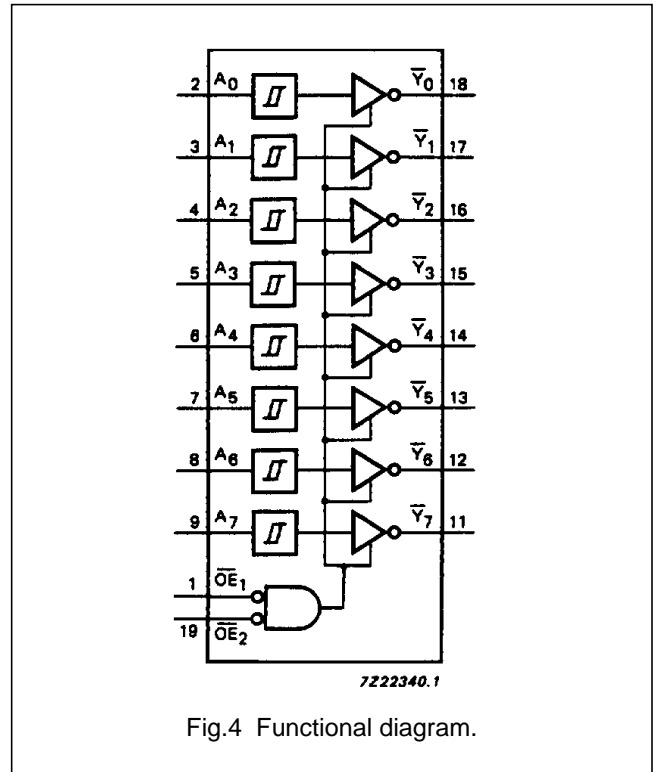

Fig.4 Functional diagram.

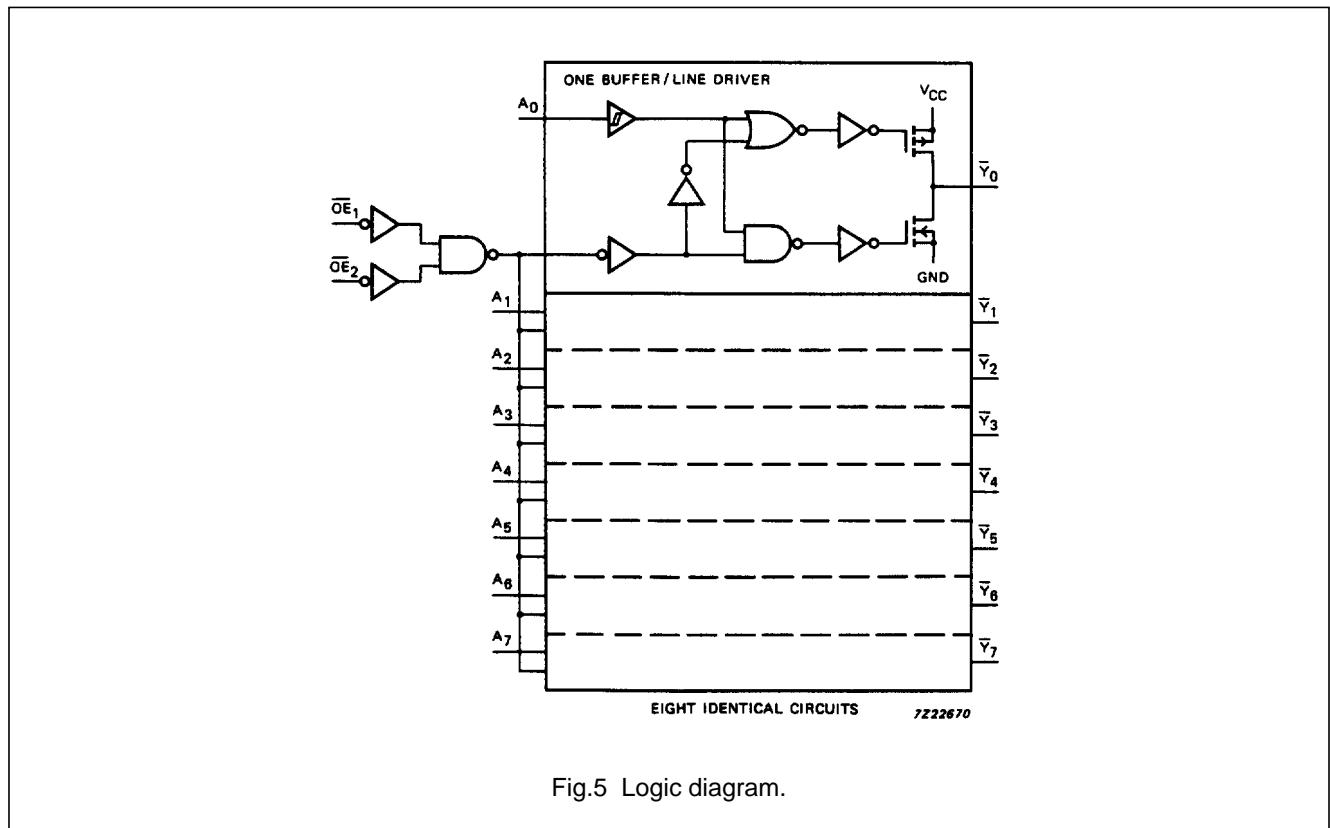

Fig.5 Logic diagram.

Octal Schmitt trigger buffer/line driver; 3-state; inverting

74HC/HCT7540

DC CHARACTERISTICS FOR 74HC

For the DC characteristics see *"74HC/HCT/HCU/HCMOS Logic Family Specifications"*.

Transfer characteristics are given below (not applicable for \overline{OE}_n inputs).

Output capability: bus driver

I_{CC} category: MSI

AC CHARACTERISTICS FOR 74HC

GND = 0 V; $t_r = t_f = 6$ ns; $C_L = 50$ pF

SYMBOL	PARAMETER	T_{amb} (°C)						UNIT	TEST CONDITIONS		
		74HC							V_{CC} (V)	WAVEFORMS	
		+25			-40 to +85		-40 to +125				
		min.	typ.	max.	min.	max.	min.				max.
t_{PHL}/t_{PLH}	propagation delay A_n to \overline{Y}_n		39 14 11	120 24 20		150 30 26		180 36 31	ns	2.0 4.5 6.0	Fig.8
t_{PZH}/t_{PZL}	3-state output enable time \overline{OE}_n to \overline{Y}_n		41 15 12	150 30 26		190 38 33		225 45 38	ns	2.0 4.5 6.0	Fig.9
t_{PHZ}/t_{PLZ}	3-state output disable time \overline{OE}_n to \overline{Y}_n		52 19 15	150 30 26		190 38 33		225 45 38	ns	2.0 4.5 6.0	Fig.9
t_{THL}/t_{TLH}	output transition time		14 5 4	60 12 10		75 15 13		90 18 15	ns	2.0 4.5 6.0	Fig.8

TRANSFER CHARACTERISTICS FOR 74HC

Voltages are referred to GND (ground = 0 V)

SYMBOL	PARAMETER	T_{amb} (°C)						UNIT	TEST CONDITIONS		
		74HC							V_{CC} (V)	WAVEFORMS	
		+25			-40 to +85		-40 to +125				
		min.	typ.	max.	min.	max.	min.				max.
V_{T+}	positive-going threshold			1.50 3.15 4.20		1.50 3.15 4.20		1.50 3.15 4.20	V	2.0 4.5 6.0	Figs 6 and 7
V_{T-}	negative-going threshold	0.30 1.35 1.80			0.30 1.35 1.80		0.30 1.35 1.80		V	2.0 4.5 6.0	Figs 6 and 7
V_H	hysteresis ($V_{T+} - V_{T-}$)	0.10 0.25 0.30	0.20 0.40 0.50		0.10 0.25 0.30		0.10 0.25 0.30		V	2.0 4.5 6.0	Figs 6 and 7

Octal Schmitt trigger buffer/line driver; 3-state; inverting

74HC/HCT7540

DC CHARACTERISTICS FOR 74HCT

For the DC characteristics see *"74HC/HCT/HCU/HCMOS Logic Family Specifications"*.

Transfer characteristics are given below (not applicable for \overline{OE}_n inputs).

Output capability: bus driver

I_{CC} category: MSI

Note to HCT types

The value of additional quiescent supply current (ΔI_{CC}) for a unit load of 1 is given in the family specifications.

To determine ΔI_{CC} per input, multiply this value by the unit load coefficient shown in the table below.

INPUT	UNIT LOAD
\overline{OE}_1	1.30
\overline{OE}_2	1.30
A_n	0.20

AC CHARACTERISTICS FOR 74HCT

GND = 0 V; $t_r = t_f = 6$ ns; $C_L = 50$ pF

SYMBOL	PARAMETER	T_{amb} (°C)								UNIT	TEST CONDITIONS	
		74HCT									V_{CC} (V)	WAVEFORMS
		+25			-40 to +85		-40 to +125					
		min	typ.	max.	min	max.	min.	max.				
t_{PHL}/t_{PLH}	propagation delay A_n to \overline{Y}_n		19	32		40		48	ns	4.5	Fig.8	
t_{PZH}/t_{PZL}	3-state output enable time \overline{OE}_n to \overline{Y}_n		19	32		40		48	ns	4.5	Fig.9	
t_{PHZ}/t_{PLZ}	3-state output disable time \overline{OE}_n to \overline{Y}_n		20	32		40		48	ns	4.5	Fig.9	
t_{THL}/t_{TLH}	output transition time		5	12		15		18	ns	4.5	Fig.8	

TRANSFER CHARACTERISTICS FOR 74HCT

Voltages are referred to GND (ground = 0 V)

SYMBOL	PARAMETER	T_{amb} (°C)								UNIT	TEST CONDITIONS	
		74HCT									V_{CC} (V)	WAVEFORMS
		+25			-40 to +85		-40 to +125					
		min	typ.	max.	min	max.	min.	max.				
V_{T+}	positive-going threshold			2.0 2.1		2.0 2.1		2.0 2.1	V	4.5 5.5	Figs 6 and 7	
V_{T-}	negative-going threshold	0.70 0.80			0.64 0.74		0.60 0.70		V	4.5 5.5	Figs 6 and 7	
V_H	hysteresis ($V_{T+} - V_{T-}$)	0.17 0.17	0.23 0.23						V	4.5 5.5	Figs 6 and 7	

Octal Schmitt trigger buffer/line driver;
3-state; inverting

74HC/HCT7540

TRANSFER CHARACTERISTIC WAVEFORMS

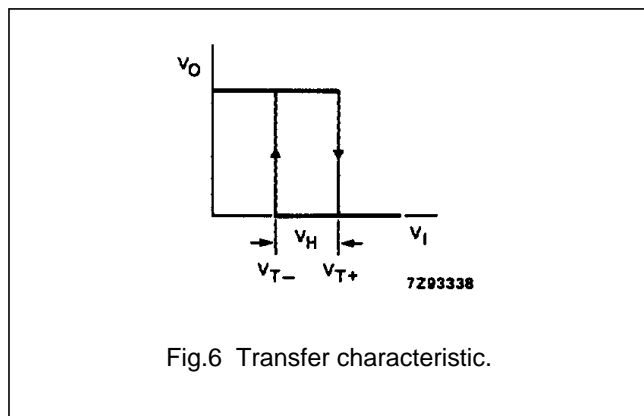

Fig.6 Transfer characteristic.

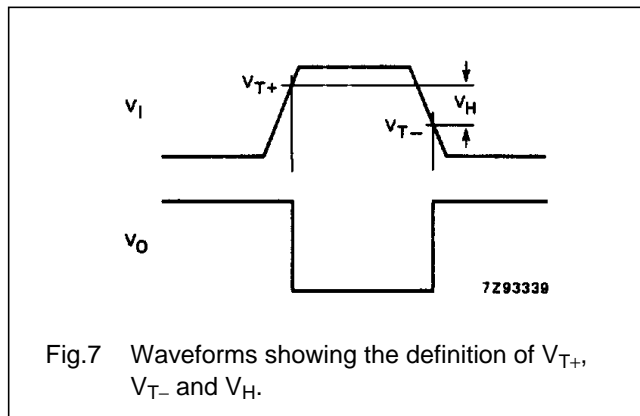

Fig.7 Waveforms showing the definition of V_{T+} , V_{T-} and V_H .

AC WAVEFORMS

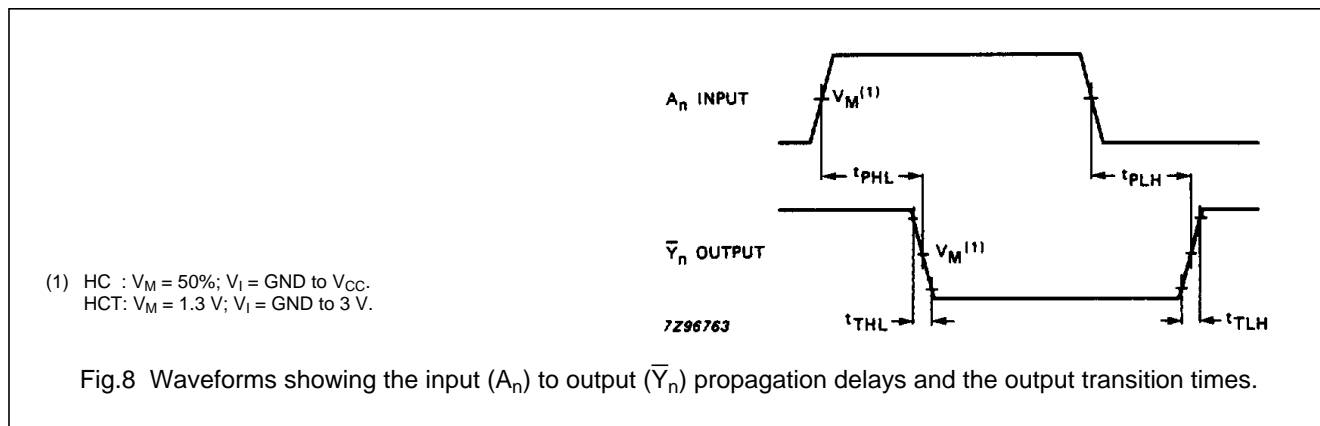

Fig.8 Waveforms showing the input (A_n) to output (\bar{Y}_n) propagation delays and the output transition times.

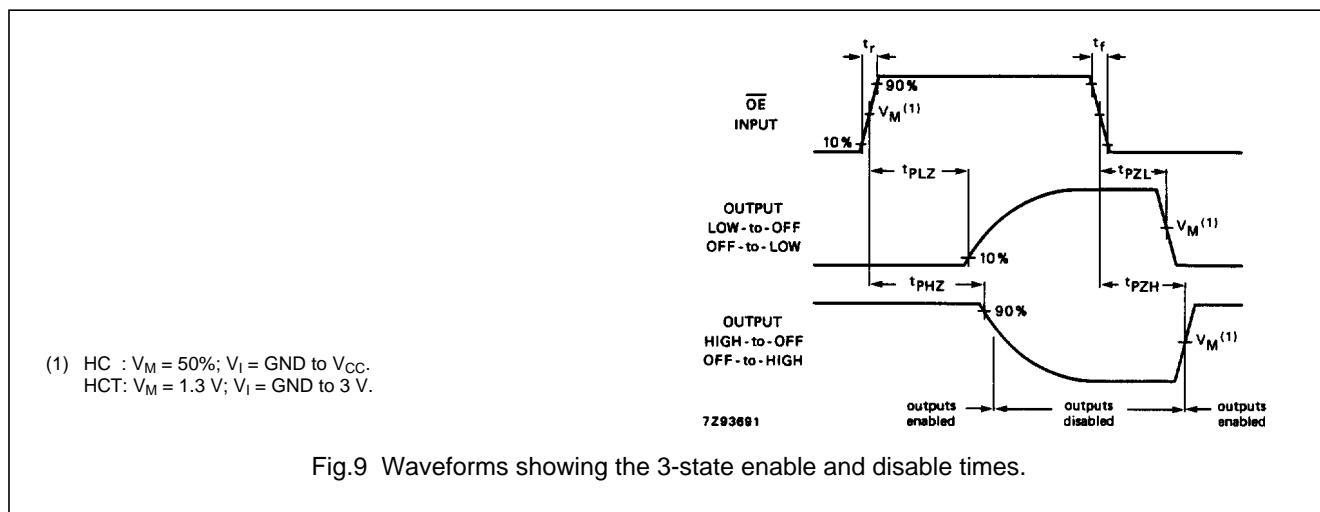

Fig.9 Waveforms showing the 3-state enable and disable times.

PACKAGE OUTLINES

See "74HC/HCT/HCU/HCMOS Logic Package Outlines".



LittleDiode supplies new, hard to find or obsolete electronic components and semiconductors all over the world.

With over two million different components listed you are sure to find the part you need.

Feel free to visit us today at our online store:

LittleDiode.com

Looking forward to providing you with the best possible service.