

74HC73

Dual JK flip-flop with reset; negative-edge trigger

Rev. 04 — 19 March 2008

Product data sheet

1. General description

The 74HC73 is a high-speed Si-gate CMOS device that complies with JEDEC standard no. 7A. It is pin compatible with Low-power Schottky TTL (LSTTL).

The 74HC73 is a dual negative-edge triggered JK flip-flop featuring individual J, K, clock ($\overline{\text{CP}}$) and reset ($\overline{\text{R}}$) inputs; also complementary nQ and $\overline{\text{nQ}}$ outputs.

The J and K inputs must be stable one set-up time prior to the HIGH-to-LOW clock transition for predictable operation.

The reset ($\overline{\text{R}}$) is an asynchronous active LOW input. When LOW, it overrides the clock and data inputs, forcing the nQ output LOW and the $\overline{\text{nQ}}$ output HIGH.

Schmitt-trigger action in the clock input makes the circuit highly tolerant to slower clock rise and fall times.

2. Features

- Low-power dissipation
- Complies with JEDEC standard no. 7A
- ESD protection:
 - ◆ HBM JESD22-A114E exceeds 2000 V
 - ◆ MM JESD22-A115-A exceeds 200 V
- Multiple package options
- Specified from $-40\text{ }^{\circ}\text{C}$ to $+80\text{ }^{\circ}\text{C}$ and from $-40\text{ }^{\circ}\text{C}$ to $+125\text{ }^{\circ}\text{C}$

3. Ordering information

Table 1. Ordering information

Type number	Package			
	Temperature range	Name	Description	Version
74HC73N	$-40\text{ }^{\circ}\text{C}$ to $+125\text{ }^{\circ}\text{C}$	DIP14	plastic dual in-line package; 14 leads (300 mil)	SOT27-1
74HC73D	$-40\text{ }^{\circ}\text{C}$ to $+125\text{ }^{\circ}\text{C}$	SO14	plastic small outline package; 14 leads; body width 3.9 mm	SOT108-1
74HC73DB	$-40\text{ }^{\circ}\text{C}$ to $+125\text{ }^{\circ}\text{C}$	SSOP14	plastic shrink small outline package; 14 leads; body width 5.3 mm	SOT337-1
74HC73PW	$-40\text{ }^{\circ}\text{C}$ to $+125\text{ }^{\circ}\text{C}$	TSSOP14	plastic thin shrink small outline package; 14 leads; body width 4.4 mm	SOT402-1

4. Functional diagram

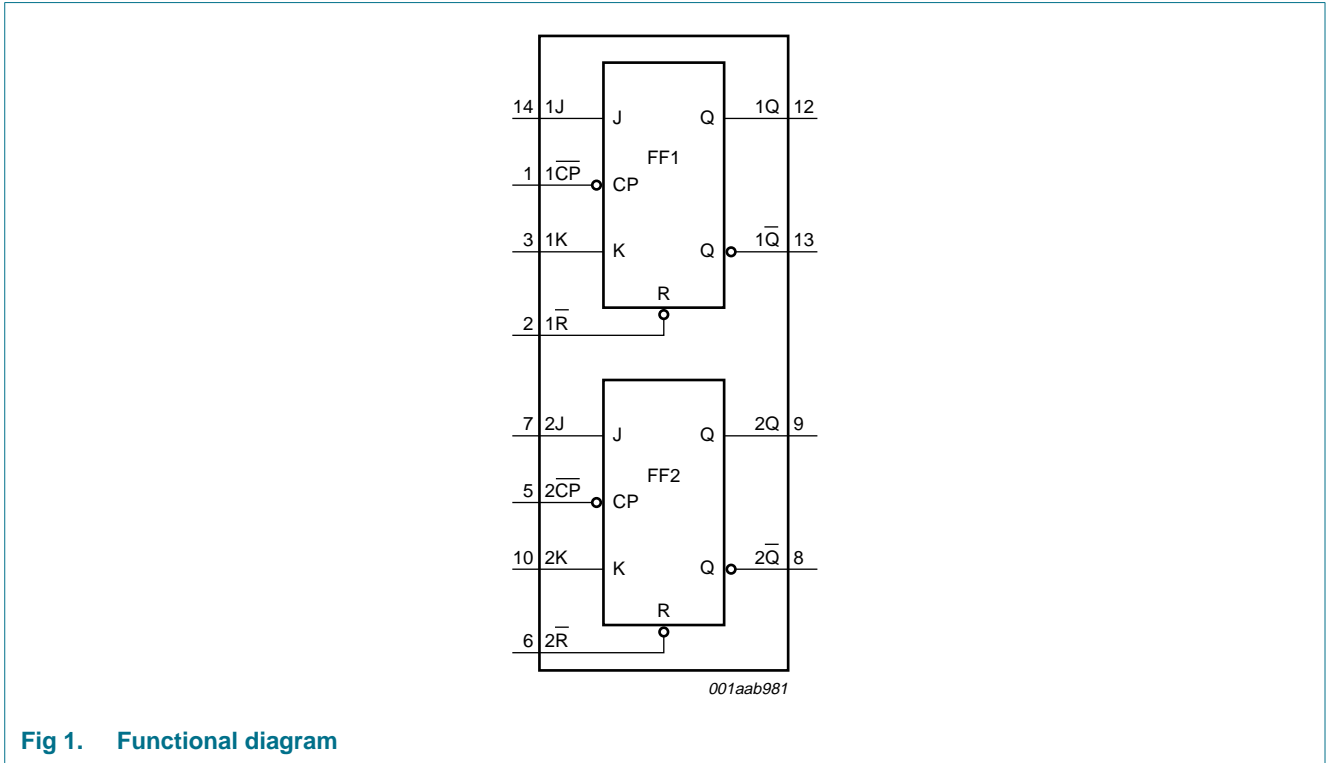

Fig 1. Functional diagram

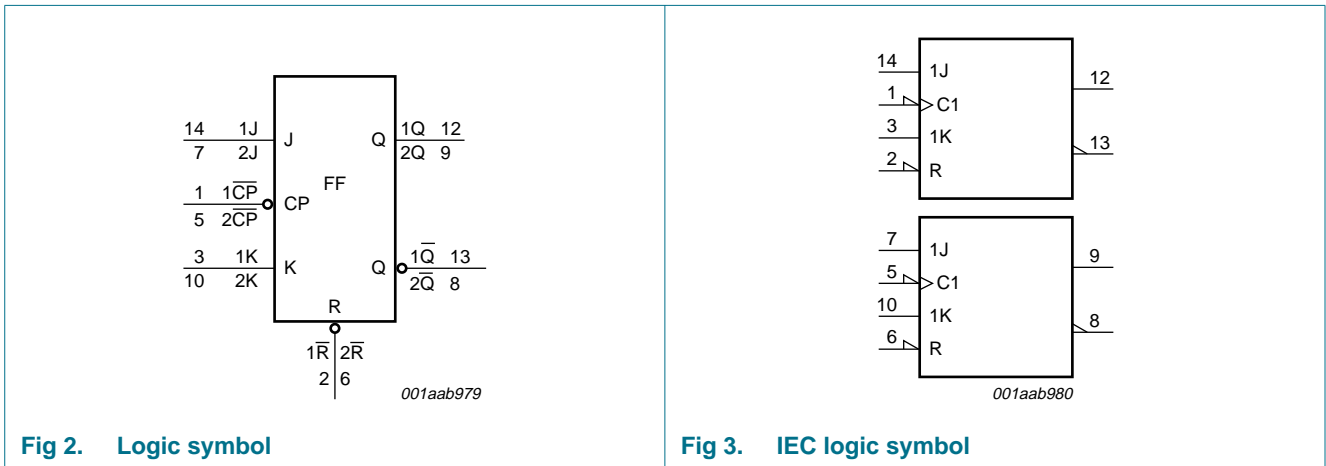

Fig 2. Logic symbol

Fig 3. IEC logic symbol

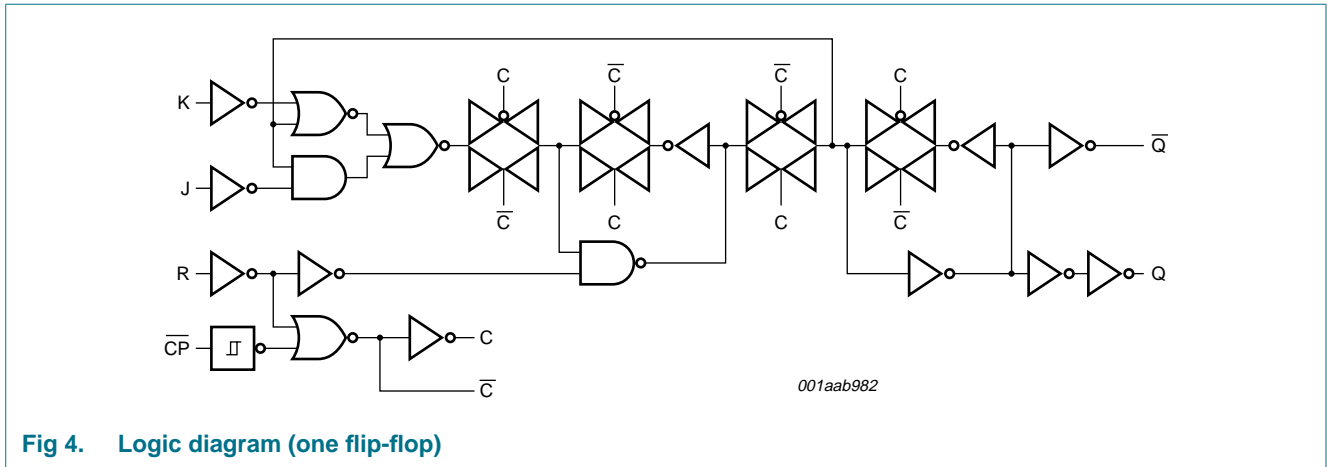

Fig 4. Logic diagram (one flip-flop)

5. Pinning information

5.1 Pinning

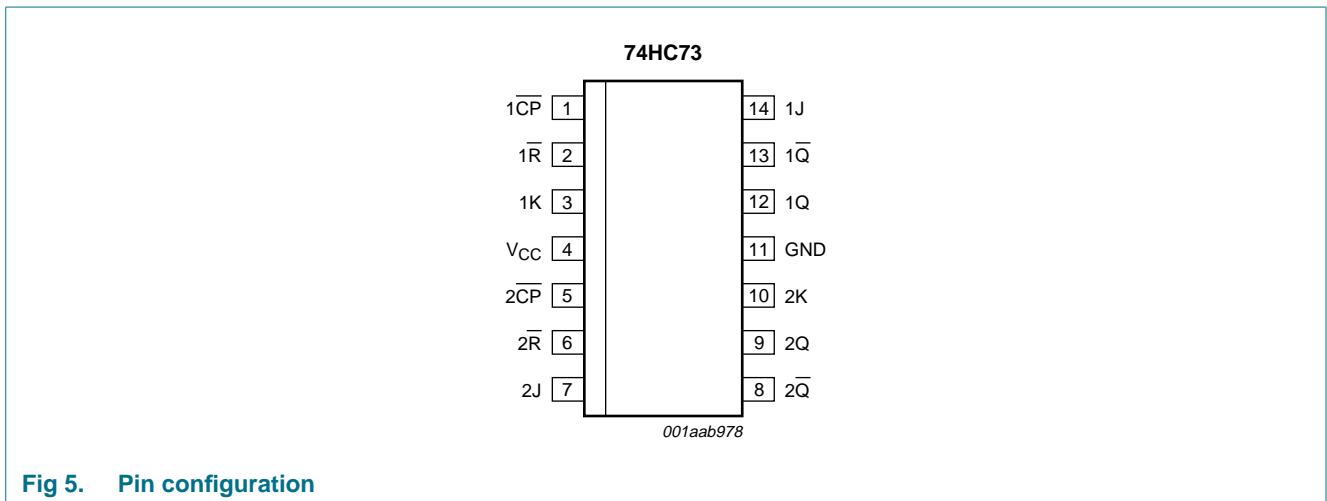

Fig 5. Pin configuration

5.2 Pin description

Table 2. Pin description

Symbol	Pin	Description
1CP, 2CP-bar	1, 5	clock input (HIGH-to-LOW edge-triggered); also referred to as nCP-bar
1R-bar, 2R-bar	2, 6	asynchronous reset input (active LOW); also referred to as nR-bar
1K, 2K	3, 10	synchronous K input; also referred to as nK
VCC	4	positive supply voltage
GND	11	ground (0 V)
1Q, 2Q	12, 9	true output; also referred to as nQ
1Q-bar, 2Q-bar	13, 8	complement output; also referred to as nQ-bar
1J, 2J	14, 7	synchronous J input; also referred to as nJ

6. Functional description

Table 3. Function table^[1]

Input				Output		Operating mode
nR	nCP	nJ	nK	nQ	nQ	
L	X	X	X	L	H	asynchronous reset
H	↓	h	h	q	q	toggle
H	↓	l	h	L	H	load 0 (reset)
H	↓	h	l	H	L	load 1 (set)
H	↓	l	l	q	q	hold (no change)

- [1] H = HIGH voltage level;
 h = HIGH voltage level one set-up time prior to the HIGH-to-LOW clock transition;
 L = LOW voltage level;
 l = LOW voltage level one set-up time prior to the HIGH-to-LOW clock transition;
 q = state of referenced output one set-up time prior to the HIGH-to-LOW clock transition;
 X = don't care;
 ↓ = HIGH-to-LOW clock transition.

7. Limiting values

Table 4. Limiting values

In accordance with the Absolute Maximum Rating System (IEC 60134). Voltages are referenced to GND (ground = 0 V).

Symbol	Parameter	Conditions	Min	Max	Unit
V _{CC}	supply voltage		-0.5	+7.0	V
I _{IK}	input clamping current	V _I < -0.5 V or V _I > V _{CC} + 0.5 V	[1] -	±20	mA
I _{OK}	output clamping current	V _O < -0.5 V or V _O > V _{CC} + 0.5 V	[1] -	±20	mA
I _O	output current	V _O = -0.5 V to V _{CC} + 0.5 V	-	±25	mA
I _{CC}	supply current		-	50	mA
I _{GND}	ground current		-50	-	mA
T _{stg}	storage temperature		-65	+150	°C
P _{tot}	total power dissipation	T _{amb} = -40 °C to +125 °C			
		DIP14 package	[2] -	750	mW
		SO14 package	[3] -	500	mW
		(T)SSOP14 package	[4] -	500	mW

- [1] The input and output voltage ratings may be exceeded if the input and output current ratings are observed.
 [2] P_{tot} derates linearly with 12 mW/K above 70 °C.
 [3] P_{tot} derates linearly with 8 mW/K above 70 °C.
 [4] P_{tot} derates linearly with 5.5 mW/K above 60 °C.

8. Recommended operating conditions

Table 5. Recommended operating conditions

Symbol	Parameter	Conditions	Min	Typ	Max	Unit
V _{CC}	supply voltage		2.0	5.0	6.0	V
V _I	input voltage		0	-	V _{CC}	V
V _O	output voltage		0	-	V _{CC}	V
T _{amb}	ambient temperature		-40	-	+125	°C
Δt/ΔV	input transition rise and fall rate	V _{CC} = 2.0 V	-	-	625	ns
		V _{CC} = 4.5 V	-	1.67	139	ns
		V _{CC} = 6.0 V	-	-	83	ns

9. Static characteristics

Table 6. Static characteristics

At recommended operating conditions; voltages are referenced to GND (ground = 0 V).

Symbol	Parameter	Conditions	25 °C			-40 °C to +85 °C		-40 °C to +125 °C		Unit
			Min	Typ	Max	Min	Max	Min	Max	
V _{IH}	HIGH-level input voltage	V _{CC} = 2.0 V	1.5	1.2	-	1.5	-	1.5	-	V
		V _{CC} = 4.5 V	3.15	2.4	-	3.15	-	3.15	-	V
		V _{CC} = 6.0 V	4.2	3.2	-	4.2	-	4.2	-	V
V _{IL}	LOW-level input voltage	V _{CC} = 2.0 V	-	0.8	0.5	-	0.5	-	0.5	V
		V _{CC} = 4.5 V	-	2.1	1.35	-	1.35	-	1.35	V
		V _{CC} = 6.0 V	-	2.8	1.8	-	1.8	-	1.8	V
V _{OH}	HIGH-level output voltage	V _I = V _{IH} or V _{IL}								
		I _O = -20 μA; V _{CC} = 2.0 V	1.9	2.0	-	1.9	-	1.9	-	V
		I _O = -20 μA; V _{CC} = 4.5 V	4.4	4.5	-	4.4	-	4.4	-	V
		I _O = -20 μA; V _{CC} = 6.0 V	5.9	6.0	-	5.9	-	5.9	-	V
		I _O = -4 mA; V _{CC} = 4.5 V	3.98	4.32	-	3.84	-	3.7	-	V
		I _O = -5.2 mA; V _{CC} = 6.0 V	5.48	5.81	-	5.34	-	5.2	-	V
V _{OL}	LOW-level output voltage	V _I = V _{IH} or V _{IL}								
		I _O = 20 μA; V _{CC} = 2.0 V	-	0	0.1	-	0.1	-	0.1	V
		I _O = 20 μA; V _{CC} = 4.5 V	-	0	0.1	-	0.1	-	0.1	V
		I _O = 20 μA; V _{CC} = 6.0 V	-	0	0.1	-	0.1	-	0.1	V
		I _O = 4 mA; V _{CC} = 4.5 V	-	0.15	0.26	-	0.33	-	0.4	V
		I _O = 5.2 mA; V _{CC} = 6.0 V	-	0.16	0.26	-	0.33	-	0.4	V
I _I	input leakage current	V _I = V _{CC} or GND; V _{CC} = 6.0 V	-	-	±0.1	-	±1.0	-	±1.0	μA
I _{CC}	supply current	V _I = V _{CC} or GND; I _O = 0 A; V _{CC} = 6.0 V	-	-	4.0	-	40.0	-	80.0	μA
C _I	input capacitance		-	3.5	-	-	-	-	-	pF

10. Dynamic characteristics

Table 7. Dynamic characteristics

GND (ground = 0 V); $C_L = 50$ pF unless otherwise specified; for test circuit, see [Figure 8](#)

Symbol	Parameter	Conditions	25 °C			-40 °C to +85 °C		-40 °C to +125 °C		Unit
			Min	Typ	Max	Min	Max	Min	Max	
t_{pd}	propagation delay	$n\overline{CP}$ to nQ; see Figure 6 ^[1]								
		$V_{CC} = 2.0$ V	-	52	160	-	200	-	240	ns
		$V_{CC} = 4.5$ V	-	19	32	-	40	-	48	ns
		$V_{CC} = 6.0$ V	-	15	27	-	34	-	41	ns
		$V_{CC} = 5.0$ V; $C_L = 15$ pF	-	16	-	-	-	-	-	ns
		$n\overline{CP}$ to n \overline{Q} ; see Figure 6								
		$V_{CC} = 2.0$ V	-	52	160	-	200	-	240	ns
		$V_{CC} = 4.5$ V	-	19	32	-	40	-	48	ns
		$V_{CC} = 6.0$ V	-	15	27	-	34	-	41	ns
		$V_{CC} = 5.0$ V; $C_L = 15$ pF	-	16	-	-	-	-	-	ns
		$n\overline{R}$ to nQ, n \overline{Q} ; see Figure 7								
		$V_{CC} = 2.0$ V	-	50	145	-	180	-	220	ns
		$V_{CC} = 4.5$ V	-	18	29	-	36	-	44	ns
$V_{CC} = 6.0$ V	-	14	25	-	31	-	38	ns		
$V_{CC} = 5.0$ V; $C_L = 15$ pF	-	15	-	-	-	-	-	ns		
t_t	transition time	nQ, n \overline{Q} ; see Figure 6 ^[2]								
		$V_{CC} = 2.0$ V	-	19	75	-	95	-	110	ns
		$V_{CC} = 4.5$ V	-	7	15	-	19	-	22	ns
		$V_{CC} = 6.0$ V	-	6	13	-	16	-	19	ns
t_W	pulse width	$n\overline{CP}$ input, HIGH or LOW; see Figure 6								
		$V_{CC} = 2.0$ V	80	22	-	100	-	120	-	ns
		$V_{CC} = 4.5$ V	16	8	-	20	-	24	-	ns
		$V_{CC} = 6.0$ V	14	6	-	17	-	20	-	ns
		$n\overline{R}$ input, HIGH or LOW; see Figure 7								
		$V_{CC} = 2.0$ V	80	22	-	100	-	120	-	ns
		$V_{CC} = 4.5$ V	16	8	-	20	-	24	-	ns
		$V_{CC} = 6.0$ V	14	6	-	17	-	20	-	ns
t_{rec}	recovery time	$n\overline{R}$ to $n\overline{CP}$; see Figure 7								
		$V_{CC} = 2.0$ V	80	22	-	100	-	120	-	ns
		$V_{CC} = 4.5$ V	16	8	-	20	-	24	-	ns
		$V_{CC} = 6.0$ V	14	6	-	17	-	20	-	ns
t_{su}	set-up time	nJ, nK to $n\overline{CP}$; see Figure 6								
		$V_{CC} = 2.0$ V	80	22	-	100	-	120	-	ns
		$V_{CC} = 4.5$ V	16	8	-	20	-	24	-	ns
		$V_{CC} = 6.0$ V	14	6	-	17	-	20	-	ns

Table 7. Dynamic characteristics ...continued
 GND (ground = 0 V); $C_L = 50 \text{ pF}$ unless otherwise specified; for test circuit, see [Figure 8](#)

Symbol	Parameter	Conditions	25 °C			-40 °C to +85 °C		-40 °C to +125 °C		Unit
			Min	Typ	Max	Min	Max	Min	Max	
t_h	hold time	nJ, nK to $\overline{\text{nCP}}$; see Figure 6								
		$V_{CC} = 2.0 \text{ V}$	3	-8	-	3	-	3	-	ns
		$V_{CC} = 4.5 \text{ V}$	3	-3	-	3	-	3	-	ns
		$V_{CC} = 6.0 \text{ V}$	3	-2	-	3	-	3	-	ns
f_{max}	maximum frequency	$\overline{\text{nCP}}$ input; see Figure 6								
		$V_{CC} = 2.0 \text{ V}$	6.0	23	-	4.8	-	4.0	-	MHz
		$V_{CC} = 4.5 \text{ V}$	30	70	-	24	-	20	-	MHz
		$V_{CC} = 6.0 \text{ V}$	35	83	-	28	-	24	-	MHz
C_{PD}	power dissipation capacitance	per flip-flop; $V_I = \text{GND to } V_{CC}$	[3]	-	30	-	-	-	-	pF

[1] t_{pd} is the same as t_{PHL} , t_{PLH} .

[2] t_t is the same as t_{THL} , t_{TLH} .

[3] C_{PD} is used to determine the dynamic power dissipation (P_D in μW).

$$P_D = C_{PD} \times V_{CC}^2 \times f_i \times N + \sum(C_L \times V_{CC}^2 \times f_o) \text{ where:}$$

f_i = input frequency in MHz;

f_o = output frequency in MHz;

C_L = output load capacitance in pF;

V_{CC} = supply voltage in V;

N = number of inputs switching;

$\sum(C_L \times V_{CC}^2 \times f_o)$ = sum of outputs.

11. Waveforms

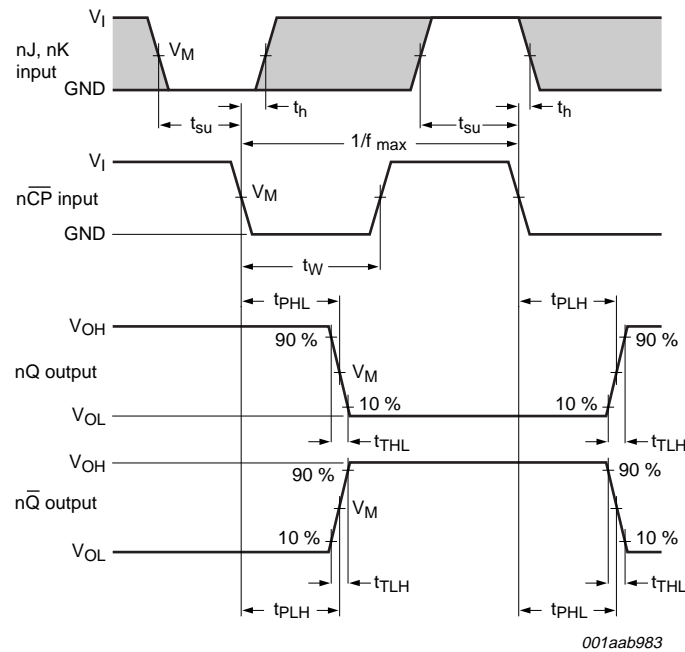

The shaded areas indicate when the input is permitted to change for predictable output performance.

Measurement points are given in [Table 8](#).

V_{OL} and V_{OH} are typical voltage output levels that occur with the output load.

Fig 6. Waveforms showing the clock (nCP) to output (nQ, nQ-bar) propagation delays, the clock pulse width, the J and K to nCP set-up and hold times, the output transition times and the maximum clock frequency

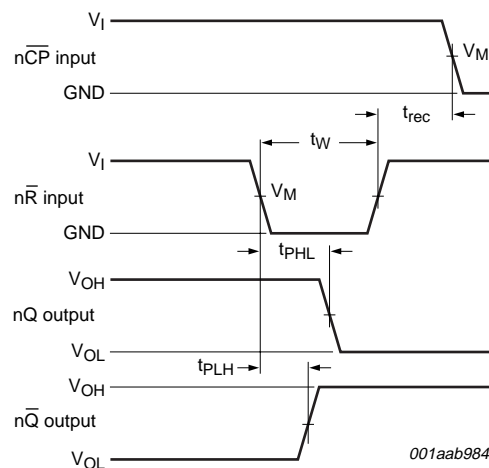

Measurement points are given in [Table 8](#).

V_{OL} and V_{OH} are typical voltage output levels that occur with the output load.

Fig 7. Waveforms showing the reset (nR) input to output (nQ, nQ-bar) propagation delays and the reset pulse width and the nR to nCP removal time

Table 8. Measurement points

Type	Input		Output
	V_I	V_M	V_M
74HC73	V_{CC}	$0.5V_{CC}$	$0.5V_{CC}$

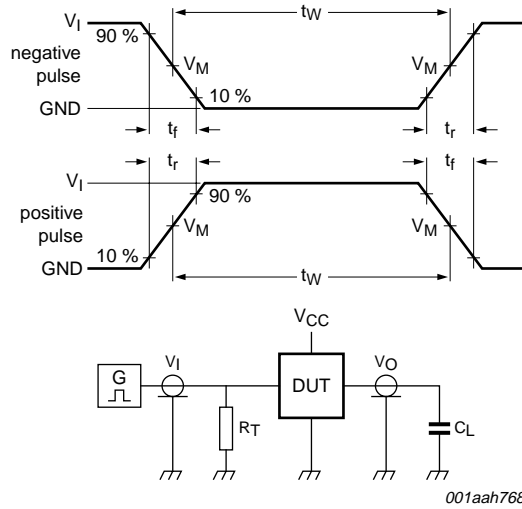

001aah768

Test data is given in [Table 9](#).

Definitions for test circuit:

R_T = Termination resistance should be equal to output impedance Z_o of the pulse generator.

C_L = Load capacitance including jig and probe capacitance.

Fig 8. Test circuit for measuring switching times

Table 9. Test data

Type	Input		Load
	V_I	t_r, t_f	C_L
74HC73	V_{CC}	6 ns	15 pF, 50 pF

12. Package outline

DIP14: plastic dual in-line package; 14 leads (300 mil)

SOT27-1

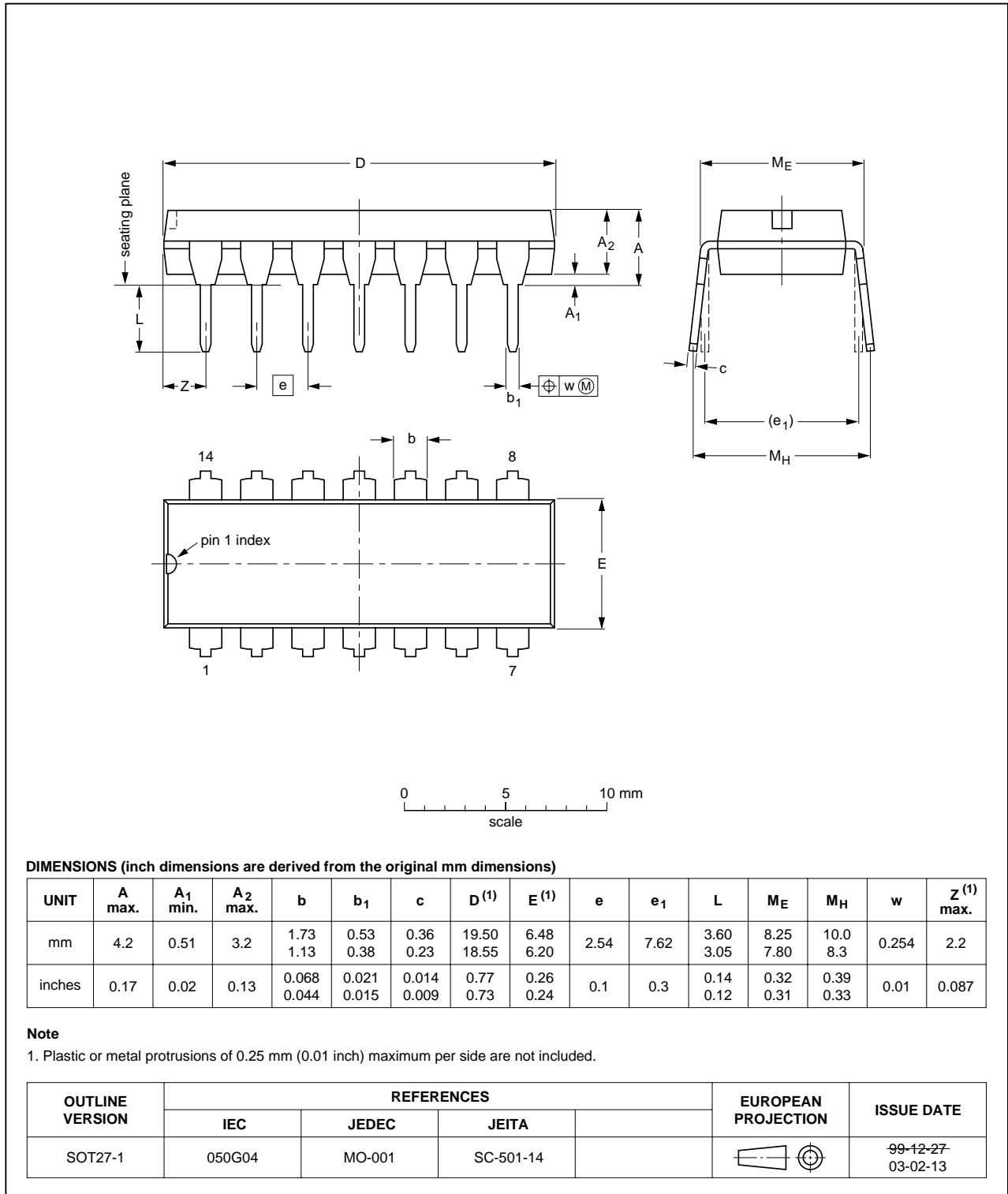

Fig 9. Package outline SOT27-1 (DIP14)

SO14: plastic small outline package; 14 leads; body width 3.9 mm

SOT108-1

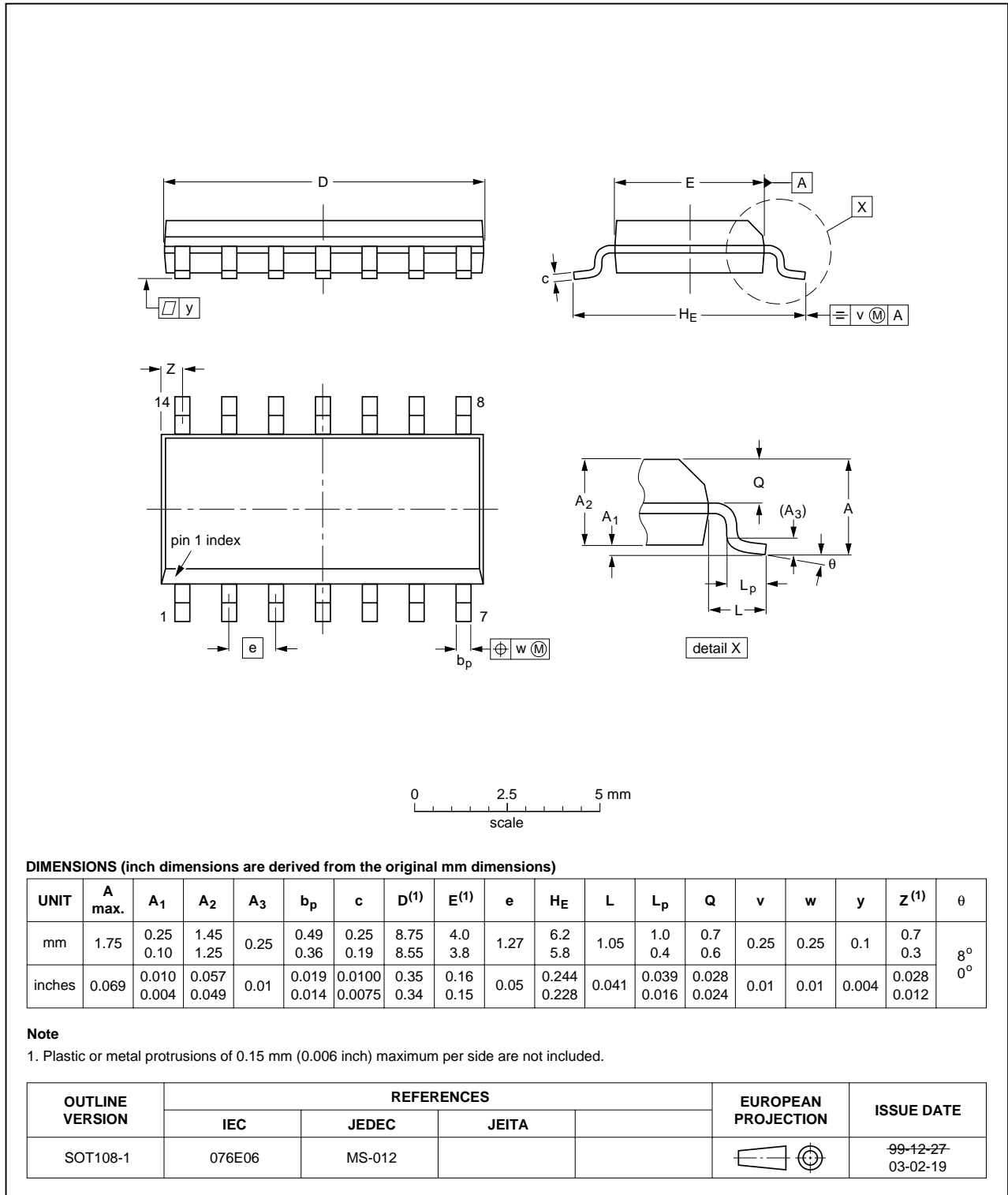

Fig 10. Package outline SOT108-1 (SO14)

SSOP14: plastic shrink small outline package; 14 leads; body width 5.3 mm

SOT337-1

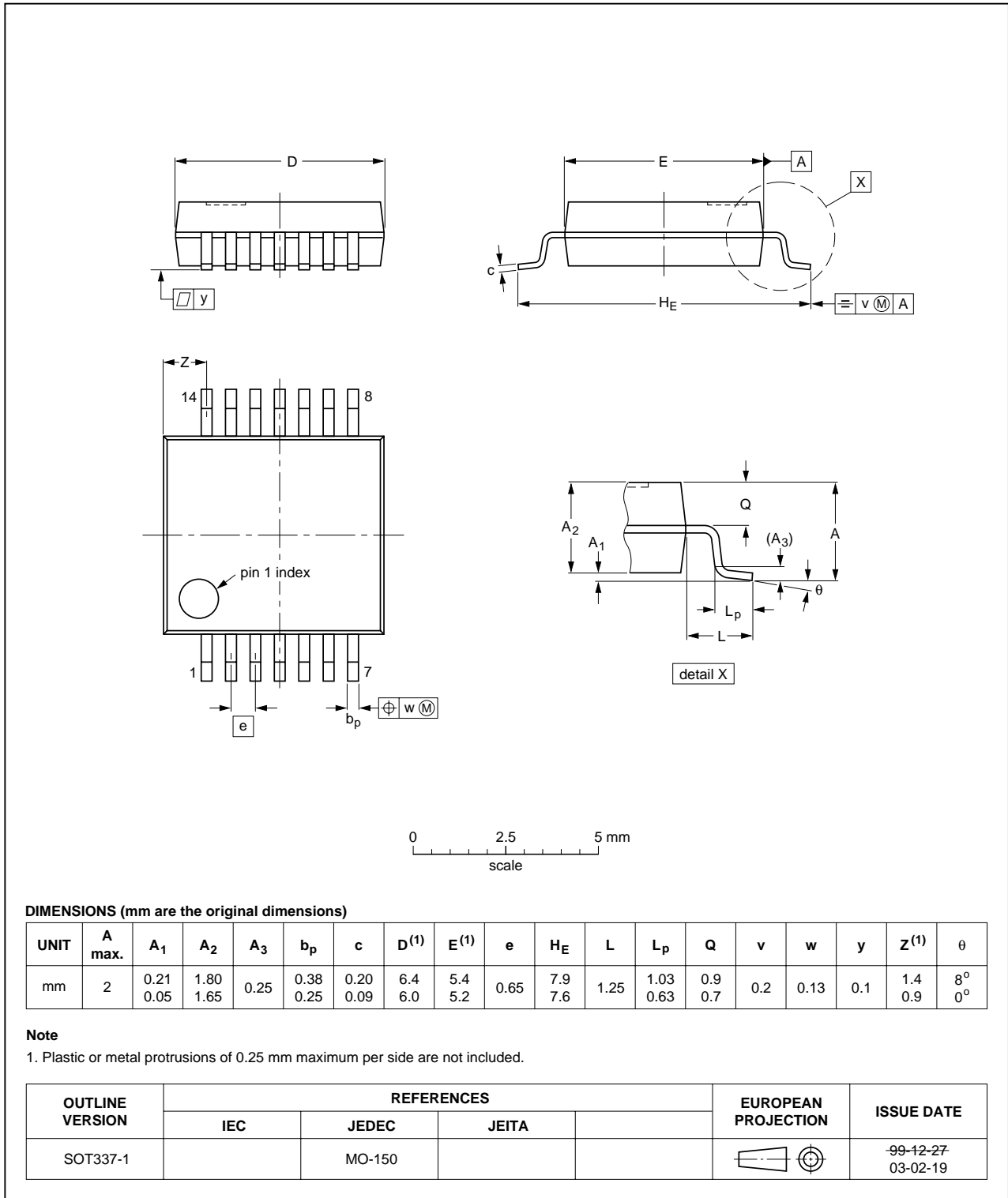

Fig 11. Package outline SOT337-1 (SSOP14)

TSSOP14: plastic thin shrink small outline package; 14 leads; body width 4.4 mm

SOT402-1

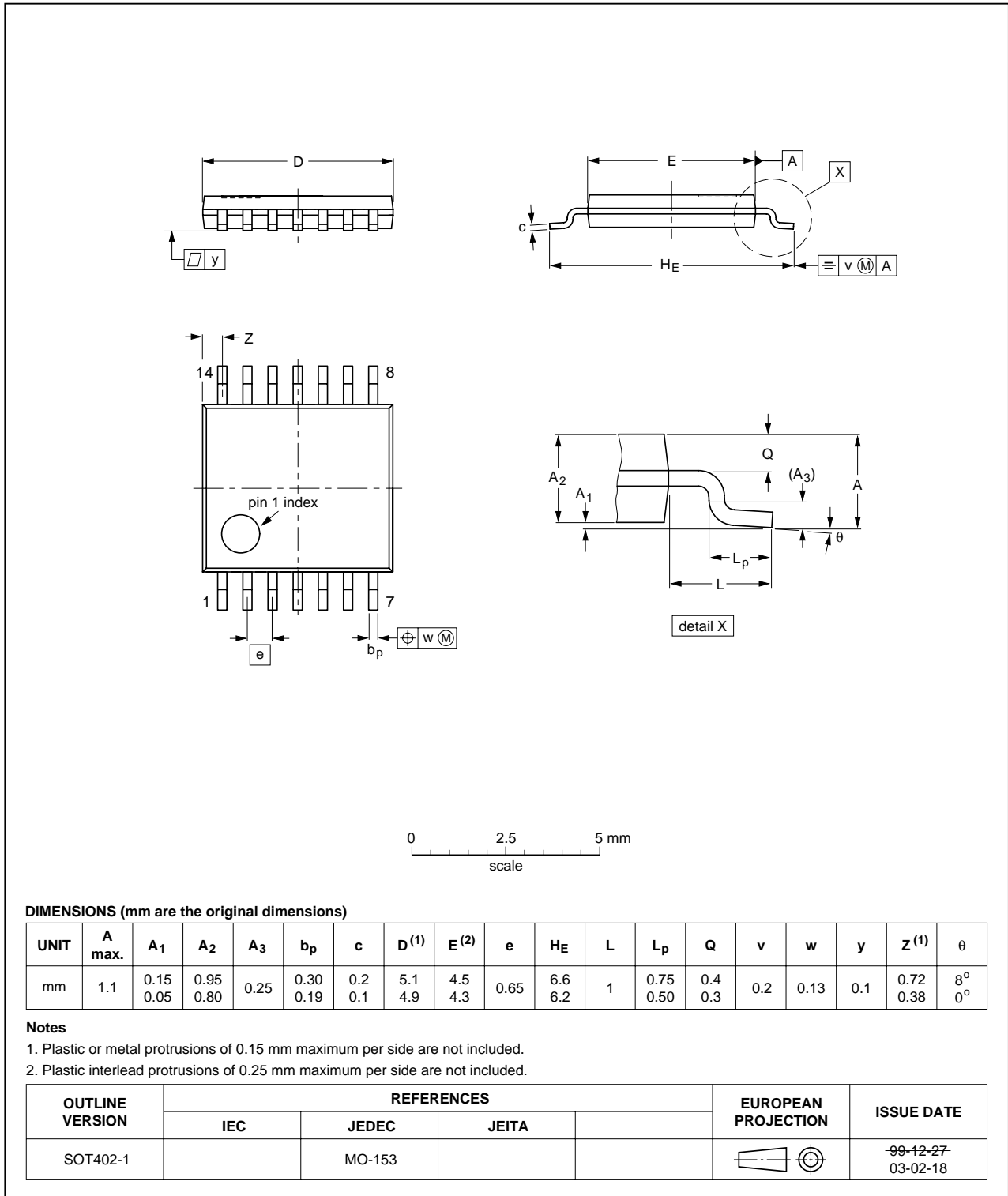

Fig 12. Package outline SOT402-1 (TSSOP14)

13. Abbreviations

Table 10. Abbreviations

Acronym	Description
CMOS	Complementary Metal-Oxide Semiconductor
DUT	Device Under Test
ESD	ElectroStatic Discharge
HBM	Human Body Model
MM	Machine Model
TTL	Transistor-Transistor Logic

14. Revision history

Table 11. Revision history

Document ID	Release date	Data sheet status	Change notice	Supersedes
74HC73_4	20080319	Product data sheet	-	74HC73_3
Modifications:	<ul style="list-style-type: none"> The format of this data sheet has been redesigned to comply with the new identity guidelines of NXP Semiconductors. Legal texts have been adapted to the new company name where appropriate. Quick reference data incorporated into Section 9 and 10. Section 8 "Recommended operating conditions" t_r, t_f converted to $\Delta t/\Delta V$. 			
74HC73_3	20041112	Product data sheet	-	74HC_HCT73_CNV_2
74HC_HCT73_CNV_2	December 1990	Product specification	-	-

15. Legal information

15.1 Data sheet status

Document status ^{[1][2]}	Product status ^[3]	Definition
Objective [short] data sheet	Development	This document contains data from the objective specification for product development.
Preliminary [short] data sheet	Qualification	This document contains data from the preliminary specification.
Product [short] data sheet	Production	This document contains the product specification.

[1] Please consult the most recently issued document before initiating or completing a design.

[2] The term 'short data sheet' is explained in section "Definitions".

[3] The product status of device(s) described in this document may have changed since this document was published and may differ in case of multiple devices. The latest product status information is available on the Internet at URL <http://www.nxp.com>.

15.2 Definitions

Draft — The document is a draft version only. The content is still under internal review and subject to formal approval, which may result in modifications or additions. NXP Semiconductors does not give any representations or warranties as to the accuracy or completeness of information included herein and shall have no liability for the consequences of use of such information.

Short data sheet — A short data sheet is an extract from a full data sheet with the same product type number(s) and title. A short data sheet is intended for quick reference only and should not be relied upon to contain detailed and full information. For detailed and full information see the relevant full data sheet, which is available on request via the local NXP Semiconductors sales office. In case of any inconsistency or conflict with the short data sheet, the full data sheet shall prevail.

15.3 Disclaimers

General — Information in this document is believed to be accurate and reliable. However, NXP Semiconductors does not give any representations or warranties, expressed or implied, as to the accuracy or completeness of such information and shall have no liability for the consequences of use of such information.

Right to make changes — NXP Semiconductors reserves the right to make changes to information published in this document, including without limitation specifications and product descriptions, at any time and without notice. This document supersedes and replaces all information supplied prior to the publication hereof.

Suitability for use — NXP Semiconductors products are not designed, authorized or warranted to be suitable for use in medical, military, aircraft, space or life support equipment, nor in applications where failure or

malfunction of an NXP Semiconductors product can reasonably be expected to result in personal injury, death or severe property or environmental damage. NXP Semiconductors accepts no liability for inclusion and/or use of NXP Semiconductors products in such equipment or applications and therefore such inclusion and/or use is at the customer's own risk.

Applications — Applications that are described herein for any of these products are for illustrative purposes only. NXP Semiconductors makes no representation or warranty that such applications will be suitable for the specified use without further testing or modification.

Limiting values — Stress above one or more limiting values (as defined in the Absolute Maximum Ratings System of IEC 60134) may cause permanent damage to the device. Limiting values are stress ratings only and operation of the device at these or any other conditions above those given in the Characteristics sections of this document is not implied. Exposure to limiting values for extended periods may affect device reliability.

Terms and conditions of sale — NXP Semiconductors products are sold subject to the general terms and conditions of commercial sale, as published at <http://www.nxp.com/profile/terms>, including those pertaining to warranty, intellectual property rights infringement and limitation of liability, unless explicitly otherwise agreed to in writing by NXP Semiconductors. In case of any inconsistency or conflict between information in this document and such terms and conditions, the latter will prevail.

No offer to sell or license — Nothing in this document may be interpreted or construed as an offer to sell products that is open for acceptance or the grant, conveyance or implication of any license under any copyrights, patents or other industrial or intellectual property rights.

15.4 Trademarks

Notice: All referenced brands, product names, service names and trademarks are the property of their respective owners.

16. Contact information

For more information, please visit: <http://www.nxp.com>

For sales office addresses, please send an email to: salesaddresses@nxp.com

17. Contents

1	General description	1
2	Features	1
3	Ordering information	1
4	Functional diagram	2
5	Pinning information	3
5.1	Pinning	3
5.2	Pin description	3
6	Functional description	4
7	Limiting values	4
8	Recommended operating conditions	5
9	Static characteristics	5
10	Dynamic characteristics	6
11	Waveforms	8
12	Package outline	10
13	Abbreviations	14
14	Revision history	14
15	Legal information	15
15.1	Data sheet status	15
15.2	Definitions	15
15.3	Disclaimers	15
15.4	Trademarks	15
16	Contact information	15
17	Contents	16

Please be aware that important notices concerning this document and the product(s) described herein, have been included in section 'Legal information'.



© NXP B.V. 2008.

All rights reserved.

For more information, please visit: <http://www.nxp.com>

For sales office addresses, please send an email to: salesaddresses@nxp.com

Date of release: 19 March 2008

Document identifier: 74HC73_4



LittleDiode supplies new, hard to find or obsolete electronic components and semiconductors all over the world.

With over two million different components listed you are sure to find the part you need.

Feel free to visit us today at our online store:

LittleDiode.com

Looking forward to providing you with the best possible service.