

# DATA SHEET

## **74HC3GU04** Inverter

Product specification  
Supersedes data of 2003 Aug 18

2003 Nov 26

## Inverter

## 74HC3GU04

## FEATURES

- Wide operating voltage range from 2.0 to 6.0 V
- Symmetrical output impedance
- High noise immunity
- Low power dissipation
- Balanced propagation delays
- SOT505-2 and SOT765-1 package
- ESD protection:  
HBM EIA/JESD22-A114-A exceeds 2000 V  
MM EIA/JESD22-A115-A exceeds 200 V.
- Specified from  $-40$  to  $+85$  °C and  $-40$  to  $+125$  °C.

## DESCRIPTION

The 74HC3GU04 is a high-speed Si-gate CMOS device.

The 74HC3GU04 provides the inverting single stage function.

## QUICK REFERENCE DATA

GND = 0 V;  $T_{amb} = 25$  °C;  $t_r = t_f \leq 6.0$  ns.

SYMBOL	PARAMETER	CONDITIONS	TYPICAL	UNIT
$t_{PHL}/t_{PLH}$	propagation delay input nA to output nY	$C_L = 50$ pF; $V_{CC} = 4.5$ V	6	ns
$C_I$	input capacitance		3	pF
$C_{PD}$	power dissipation capacitance	notes 1 and 2	5	pF

## Notes

1.  $C_{PD}$  is used to determine the dynamic power dissipation ( $P_D$  in  $\mu W$ ).

$P_D = C_{PD} \times V_{CC}^2 \times f_i \times N + \Sigma(C_L \times V_{CC}^2 \times f_o)$  where:

$f_i$  = input frequency in MHz;

$f_o$  = output frequency in MHz;

$C_L$  = output load capacitance in pF;

$V_{CC}$  = supply voltage in Volts;

$N$  = total switching outputs;

$\Sigma(C_L \times V_{CC}^2 \times f_o)$  = sum of outputs.

2. The condition is  $V_I = \text{GND to } V_{CC}$ .

## FUNCTION TABLE

See note 1.

INPUT	OUTPUT
nA	nY
L	H
H	L

## Note

1. H = HIGH voltage level;  
L = LOW voltage level.

Inverter

74HC3GU04

ORDERING INFORMATION

TYPE NUMBER	PACKAGE					
	TEMPERATURE RANGE	PINS	PACKAGE	MATERIAL	CODE	MARKING
74HC3GU04DP	-40 to +125 °C	8	TSSOP8	plastic	SOT505-2	HU04
74HC3GU04DC	-40 to +125 °C	8	VSSOP8	plastic	SOT765-1	HU4

PINNING

PIN	SYMBOL	DESCRIPTION
1	1A	data input
2	3Y	data output
3	2A	data input
4	GND	ground (0 V)
5	2Y	data output
6	3A	data input
7	1Y	data output
8	V <sub>CC</sub>	supply voltage

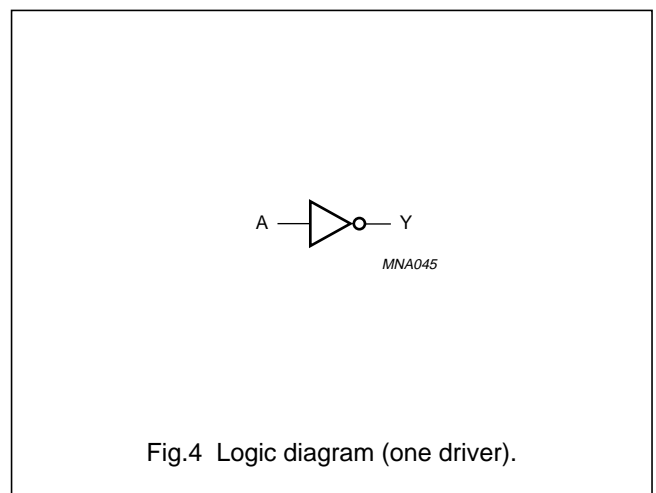
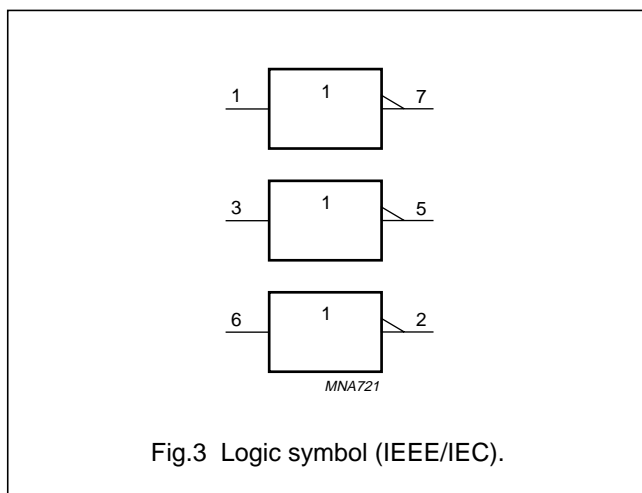
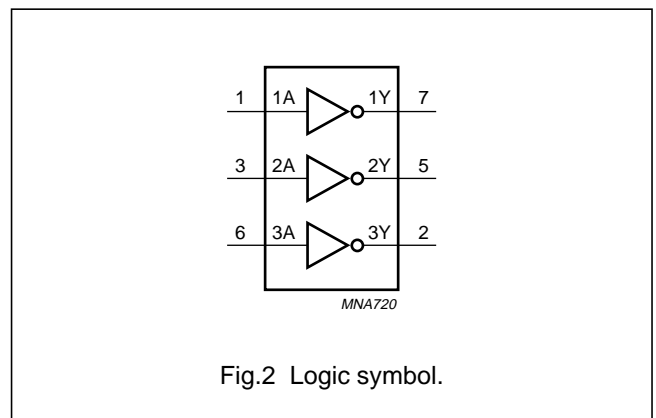
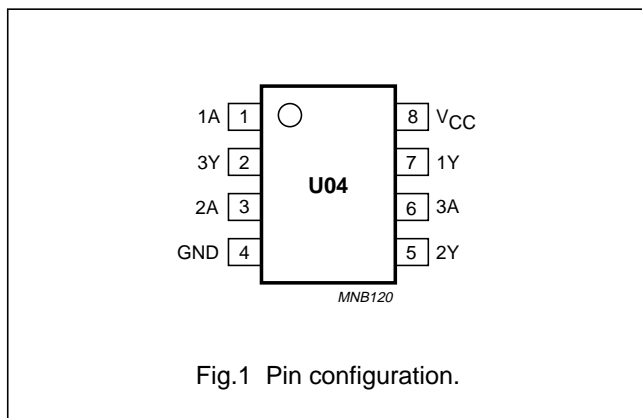

## Inverter

## 74HC3GU04

## RECOMMENDED OPERATING CONDITIONS

SYMBOL	PARAMETER	CONDITIONS	MIN.	TYP.	MAX.	UNIT
$V_{CC}$	supply voltage		2.0	5.0	6.0	V
$V_I$	input voltage		0	–	$V_{CC}$	V
$V_O$	output voltage		0	–	$V_{CC}$	V
$T_{amb}$	operating ambient temperature		–40	+25	+125	°C
$t_r, t_f$	input rise and fall times	$V_{CC} = 2.0\text{ V}$	–	–	1000	ns
		$V_{CC} = 4.5\text{ V}$	–	6.0	500	ns
		$V_{CC} = 6.0\text{ V}$	–	–	400	ns

## LIMITING VALUES

In accordance with the Absolute Maximum Rating System (IEC 60134); voltages are referenced to GND (ground = 0 V).

SYMBOL	PARAMETER	CONDITIONS	MIN.	MAX.	UNIT
$V_{CC}$	supply voltage		–0.5	+7.0	V
$I_{IK}$	input diode current	$V_I < -0.5\text{ V}$ or $V_I > V_{CC} + 0.5\text{ V}$ ; note 1	–	$\pm 20$	mA
$I_{OK}$	output diode current	$V_O < -0.5\text{ V}$ or $V_O > V_{CC} + 0.5\text{ V}$ ; note 1	–	$\pm 20$	mA
$I_O$	output source or sink current	$-0.5\text{ V} < V_O < V_{CC} + 0.5\text{ V}$ ; note 1	–	$\pm 25$	mA
$I_{CC}, I_{GND}$	$V_{CC}$ or GND current	note 1	–	$\pm 50$	mA
$T_{stg}$	storage temperature		–65	+150	°C
$P_D$	power dissipation	$T_{amb} = -40\text{ to }+125\text{ °C}$ ; note 2	–	300	mW

## Notes

1. The input and output voltage ratings may be exceeded if the input and output current ratings are observed.
2. Above 110 °C the value of  $P_D$  derates linearly with 8 mW/K.

## Inverter

## 74HC3GU04

**DC CHARACTERISTICS**

At recommended operating conditions; voltages are referenced to GND (ground = 0 V).

SYMBOL	PARAMETER	TEST CONDITIONS		MIN.	TYP.	MAX.	UNIT
		OTHER	V <sub>CC</sub> (V)				
<b>T<sub>amb</sub> = -40 to +85 °C; note 1</b>							
V <sub>IH</sub>	HIGH-level input voltage		2.0	1.7	1.1	–	V
			4.5	3.6	2.4	–	V
			6.0	4.8	3.1	–	V
V <sub>IL</sub>	LOW-level input voltage		2.0	–	0.9	0.3	V
			4.5	–	2.1	0.9	V
			6.0	–	2.9	1.2	V
V <sub>OH</sub>	HIGH-level output voltage	V <sub>I</sub> = V <sub>IH</sub> or V <sub>IL</sub>	2.0	1.9	2.0	–	V
		I <sub>O</sub> = -20 μA	4.5	4.4	4.5	–	V
		I <sub>O</sub> = -20 μA	6.0	5.9	6.0	–	V
		I <sub>O</sub> = -4.0 mA	4.5	4.13	4.32	–	V
		I <sub>O</sub> = -5.2 mA	6.0	5.63	5.81	–	V
V <sub>OL</sub>	LOW-level output voltage	V <sub>I</sub> = V <sub>IH</sub> or V <sub>IL</sub>	2.0	–	0	0.1	V
		I <sub>O</sub> = 20 μA	4.5	–	0	0.1	V
		I <sub>O</sub> = 20 μA	6.0	–	0	0.1	V
		I <sub>O</sub> = 4.0 mA	4.5	–	0.15	0.33	V
		I <sub>O</sub> = 5.2 mA	6.0	–	0.16	0.33	V
I <sub>LI</sub>	input leakage current	V <sub>I</sub> = V <sub>CC</sub> or GND	6.0	–	–	±1.0	μA
I <sub>CC</sub>	quiescent supply current	V <sub>I</sub> = V <sub>CC</sub> or GND; I <sub>O</sub> = 0	6.0	–	–	10	μA

## Inverter

## 74HC3GU04

SYMBOL	PARAMETER	TEST CONDITIONS		MIN.	TYP.	MAX.	UNIT
		OTHER	V <sub>CC</sub> (V)				
<b>T<sub>amb</sub> = -40 to +125 °C</b>							
V <sub>IH</sub>	HIGH-level input voltage		2.0	1.7	–	–	V
			4.5	3.6	–	–	V
			6.0	4.8	–	–	V
V <sub>IL</sub>	LOW-level input voltage		2.0	–	–	0.3	V
			4.5	–	–	0.9	V
			6.0	–	–	1.2	V
V <sub>OH</sub>	HIGH-level output voltage	V <sub>I</sub> = V <sub>IH</sub> or V <sub>IL</sub> I <sub>O</sub> = -20 µA	2.0	1.9	–	–	V
		I <sub>O</sub> = -20 µA	4.5	4.4	–	–	V
		I <sub>O</sub> = -20 µA	6.0	5.9	–	–	V
		I <sub>O</sub> = -4.0 mA	4.5	3.7	–	–	V
		I <sub>O</sub> = -5.2 mA	6.0	5.2	–	–	V
V <sub>OL</sub>	LOW-level output voltage	V <sub>I</sub> = V <sub>IH</sub> or V <sub>IL</sub> I <sub>O</sub> = 20 µA	2.0	–	–	0.1	V
		I <sub>O</sub> = 20 µA	4.5	–	–	0.1	V
		I <sub>O</sub> = 20 µA	6.0	–	–	0.1	V
		I <sub>O</sub> = 4.0 mA	4.5	–	–	0.4	V
		I <sub>O</sub> = 5.2 mA	6.0	–	–	0.4	V
I <sub>LI</sub>	input leakage current	V <sub>I</sub> = V <sub>CC</sub> or GND	6.0	–	–	±1.0	µA
I <sub>CC</sub>	quiescent supply current	V <sub>I</sub> = V <sub>CC</sub> or GND; I <sub>O</sub> = 0	6.0	–	–	20	µA

**Note**

1. All typical values are measured at T<sub>amb</sub> = 25 °C.

Inverter

74HC3GU04

**AC CHARACTERISTICS**

GND = 0 V;  $t_r = t_f \leq 6.0$  ns.

SYMBOL	PARAMETER	TEST CONDITIONS		MIN.	TYP.	MAX.	UNIT
		WAVEFORMS	V <sub>CC</sub> (V)				
<b>T<sub>amb</sub> = -40 to +85 °C; note 1</b>							
t <sub>PHL</sub> /t <sub>PLH</sub>	propagation delay input nA to output nY	see Figs.5 and 6	2.0	-	13	75	ns
			4.5	-	6	15	ns
			6.0	-	5	13	ns
t <sub>THL</sub> /t <sub>TLH</sub>	output transition time	see Figs.5 and 6	2.0	-	18	95	ns
			4.5	-	6	19	ns
			6.0	-	5	16	ns
<b>T<sub>amb</sub> = -40 to +125 °C</b>							
t <sub>PHL</sub> /t <sub>PLH</sub>	propagation delay input nA to output nY	see Figs.5 and 6	2.0	-	-	90	ns
			4.5	-	-	18	ns
			6.0	-	-	15	ns
t <sub>THL</sub> /t <sub>TLH</sub>	output transition time	see Figs.5 and 6	2.0	-	-	125	ns
			4.5	-	-	25	ns
			6.0	-	-	20	ns

**Note**

1. All typical values are measured at T<sub>amb</sub> = 25 °C.

**AC WAVEFORMS**

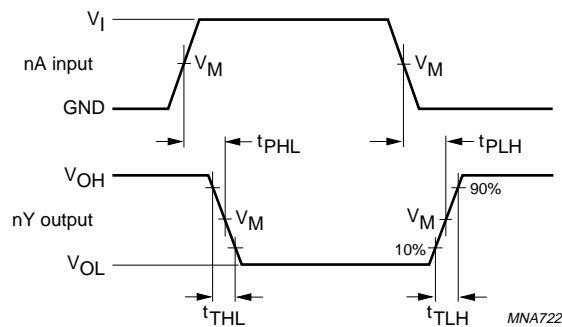

V<sub>M</sub> = 50%; V<sub>I</sub> = GND to V<sub>CC</sub>.

Fig.5 The input (nA) to output (nY) propagation delays and the output transition times.

Inverter

74HC3GU04

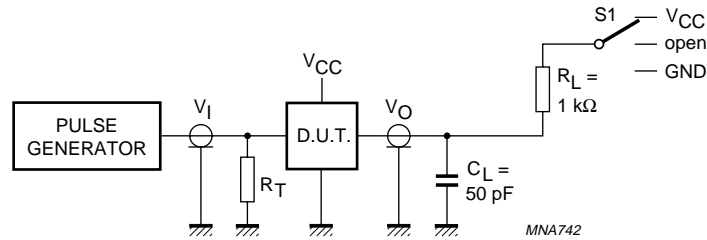

TEST	S1
$t_{PLH}/t_{PHL}$	open
$t_{PLZ}/t_{PZL}$	$V_{CC}$
$t_{PHZ}/t_{PZH}$	GND

Definitions for test circuit:

$R_L$  = load resistor.

$C_L$  = load capacitance including jig and probe capacitance.

$R_T$  = termination resistance should be equal to the output impedance  $Z_o$  of the pulse generator.

Fig.6 Load circuitry for switching times.

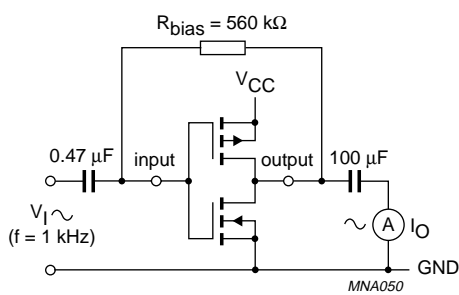

$$g_{fs} = \frac{\Delta I_O}{\Delta V_I}$$

$V_O$  is constant.

Fig.7 Test set-up for measuring forward transconductance.

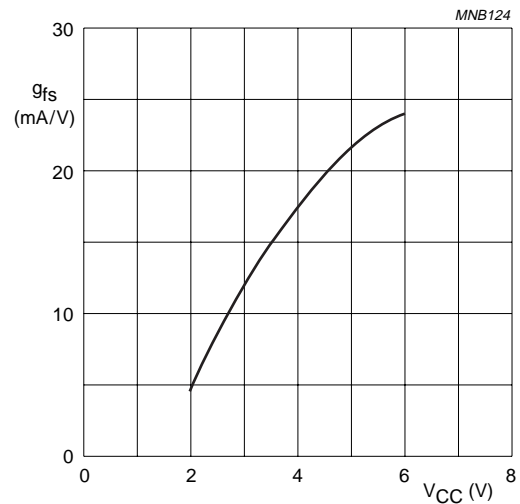

$T_{amb} = 25\text{ }^\circ\text{C}$ .

Fig.8 Typical forward transconductance ( $g_{fs}$ ) as a function of the supply voltage ( $V_{CC}$ ).

Inverter

74HC3GU04

TYPICAL TRANSFER CHARACTERISTICS

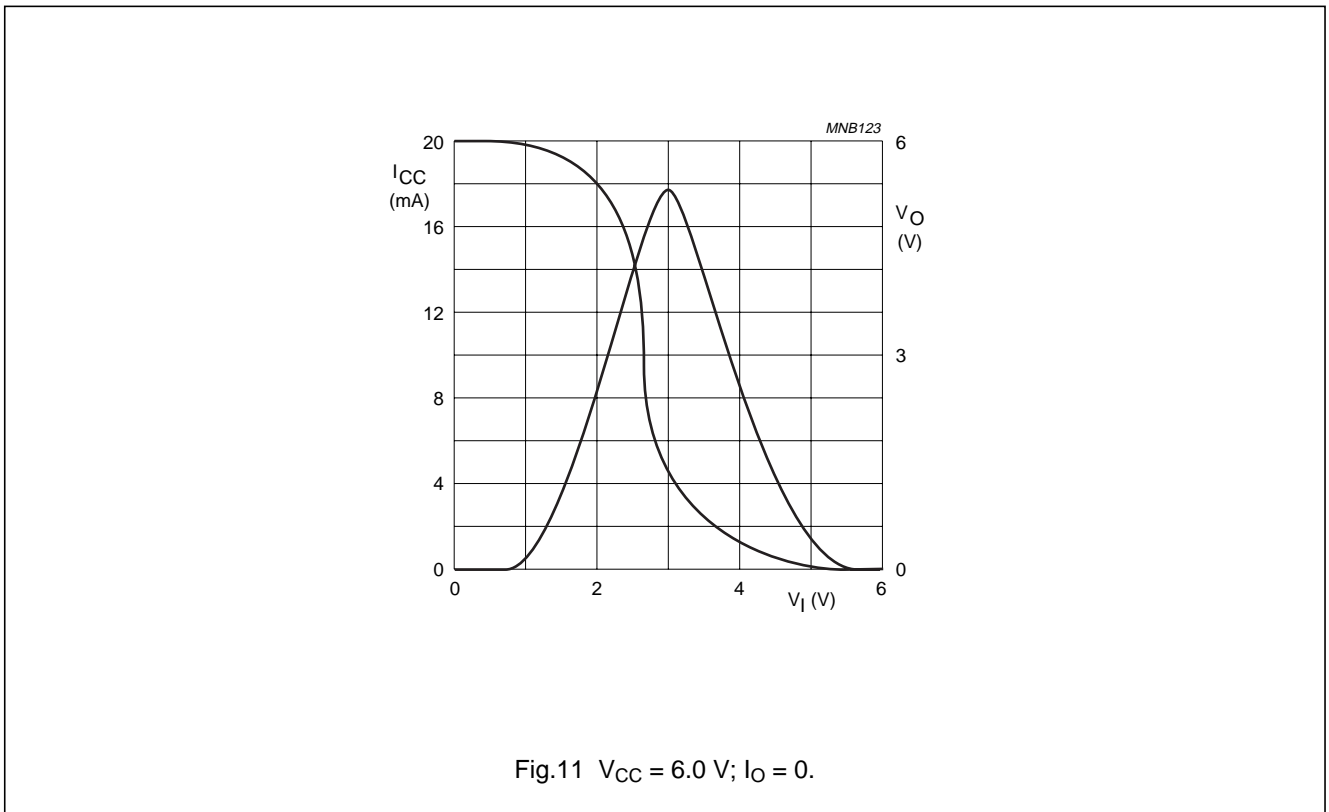
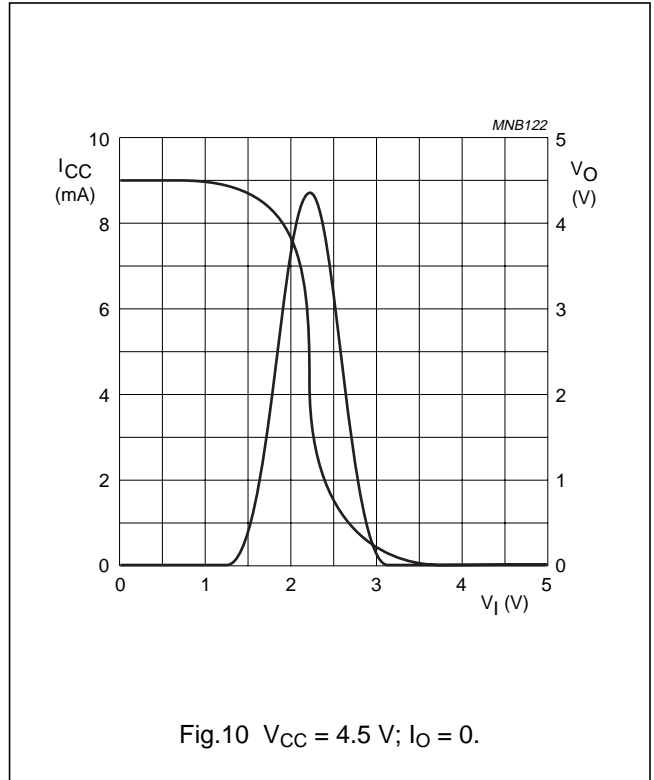
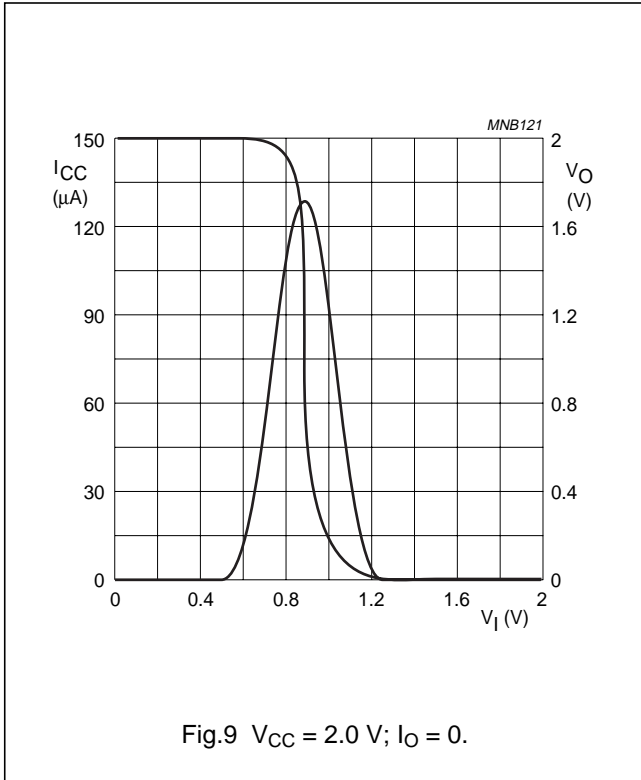

# Inverter

# 74HC3GU04

## APPLICATION INFORMATION

All values given are typical unless otherwise specified.

### Linear amplifier

$V_{O(max)}(p-p) = V_{CC} - 1.5\text{ V}$  centered at  $0.5V_{CC}$  ;  

$$A_u = -\frac{A_{OL}}{1 + \frac{R1}{R2}(1 + A_{OL})}$$

$A_{OL}$  = open loop amplification.  
 $A_u$  = voltage amplification.  
 $R1 \geq 3\text{ k}\Omega$ ,  $R2 \leq 1\text{ M}\Omega$ .  
 $Z_L > 10\text{ k}\Omega$ ;  $A_{OL} = 20$  (typical).  
 Typical unity gain bandwidth product is 5 MHz.  
 Input capacitance see Fig.13.

Fig.12 Linear amplifier configuration.

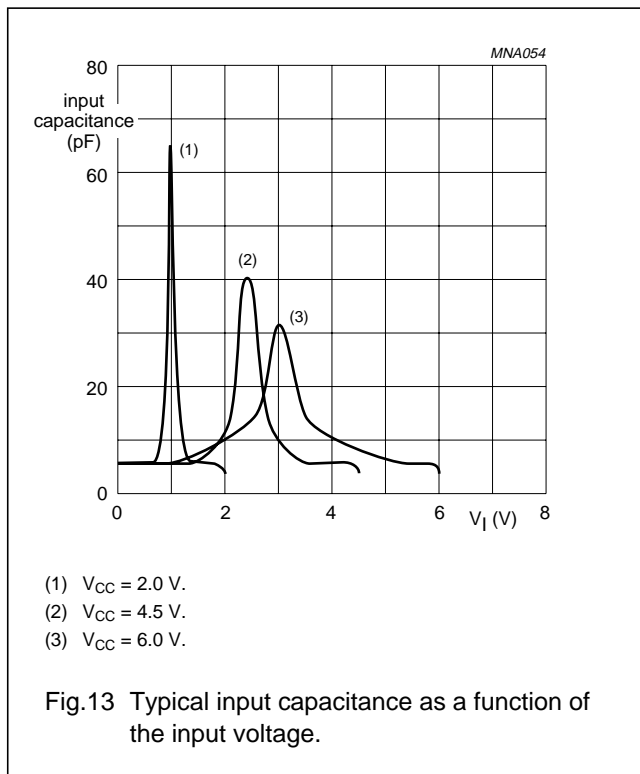

### Crystal oscillator

$C1 = 47\text{ pF}$  (typical).  
 $C2 = 22\text{ pF}$  (typical).  
 $R1 = 1$  to  $10\text{ M}\Omega$  (typical).  
 $R2$  optimum value depends on the frequency and required stability against changes in  $V_{CC}$  or average minimum  $I_{CC}$  ( $I_{CC}$  is typically 2 mA at  $V_{CC} = 3\text{ V}$  and  $f = 1\text{ MHz}$ ).

Fig.14 Crystal oscillator configuration.

Table 1 External components for resonator ( $f < 1\text{ MHz}$ )

FREQUENCY (kHz)	R1 (MΩ)	R2 (kΩ)	C1 (pF)	C2 (pF)
10 to 15.9	2.2	220	56	20
16 to 24.9	2.2	220	56	10
25 to 54.9	2.2	100	56	10
55 to 129.9	2.2	100	47	5
130 to 199.9	2.2	47	47	5
200 to 349.9	2.2	47	47	5
350 to 600	2.2	47	47	5

All values given are typical and must be used as an initial set-up.

Table 2 Optimum value for R2

FREQUENCY (kHz)	R2 (kΩ)	OPTIMUM FOR
3	2.0	minimum required $I_{CC}$
	8.0	minimum influence due to change in $V_{CC}$
6	1.0	minimum required $I_{CC}$
	4.7	minimum influence by $V_{CC}$
10	0.5	minimum required $I_{CC}$
	2.0	minimum influence by $V_{CC}$
14	0.5	minimum required $I_{CC}$
	1.0	minimum influence by $V_{CC}$
>14	replace R2 by C3 = 35 pF (typical)	

Inverter

74HC3GU04

PACKAGE OUTLINES

TSSOP8: plastic thin shrink small outline package; 8 leads; body width 3 mm; lead length 0.5 mm SOT505-2

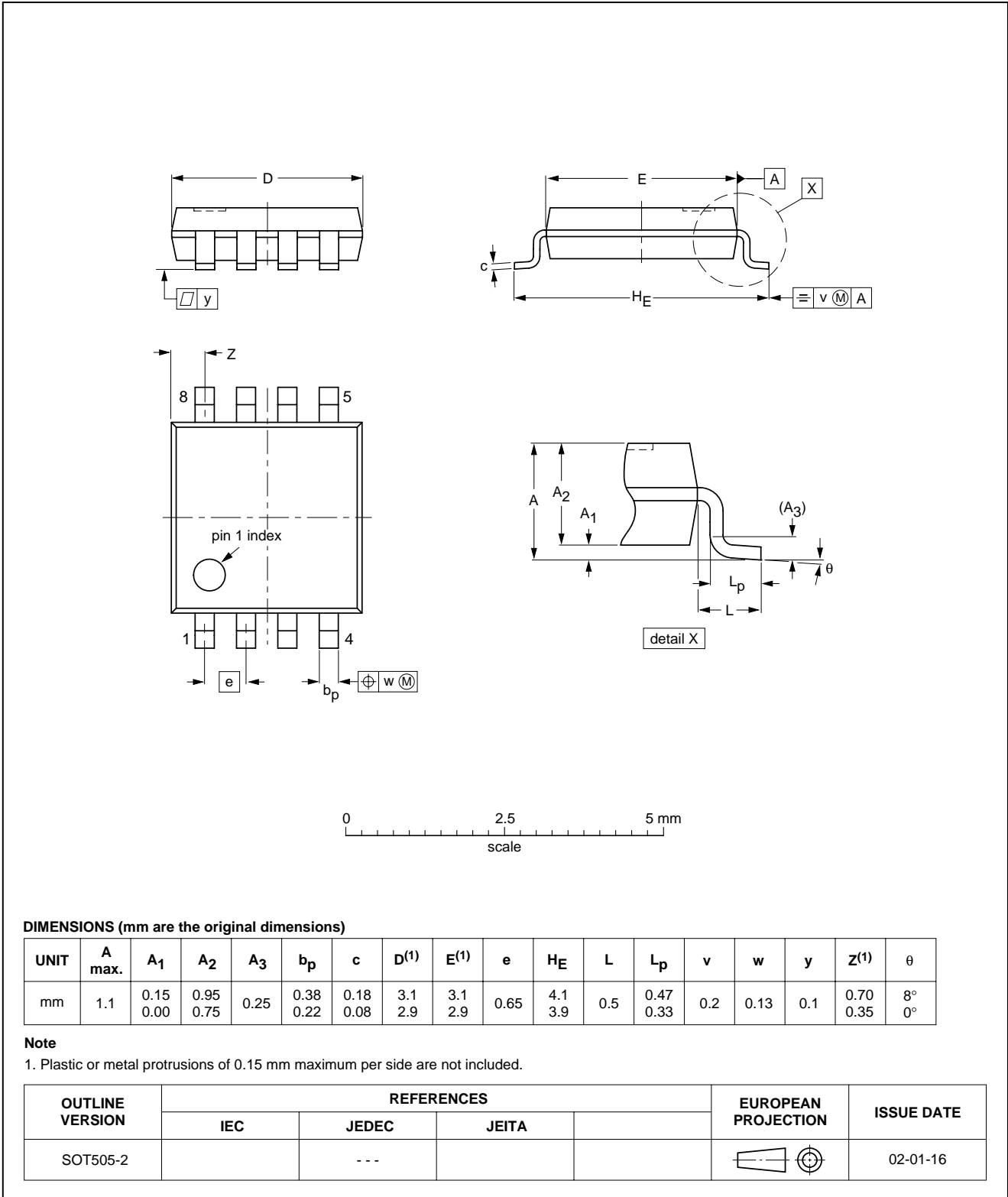

DIMENSIONS (mm are the original dimensions)

UNIT	A max.	A <sub>1</sub>	A <sub>2</sub>	A <sub>3</sub>	b <sub>p</sub>	c	D <sup>(1)</sup>	E <sup>(1)</sup>	e	H <sub>E</sub>	L	L <sub>p</sub>	v	w	y	Z <sup>(1)</sup>	θ
mm	1.1	0.15 0.00	0.95 0.75	0.25	0.38 0.22	0.18 0.08	3.1 2.9	3.1 2.9	0.65	4.1 3.9	0.5	0.47 0.33	0.2	0.13	0.1	0.70 0.35	8° 0°

Note

1. Plastic or metal protrusions of 0.15 mm maximum per side are not included.

OUTLINE VERSION	REFERENCES				EUROPEAN PROJECTION	ISSUE DATE
	IEC	JEDEC	JEITA			
SOT505-2		---				02-01-16

Inverter

74HC3GU04

VSSOP8: plastic very thin shrink small outline package; 8 leads; body width 2.3 mm

SOT765-1

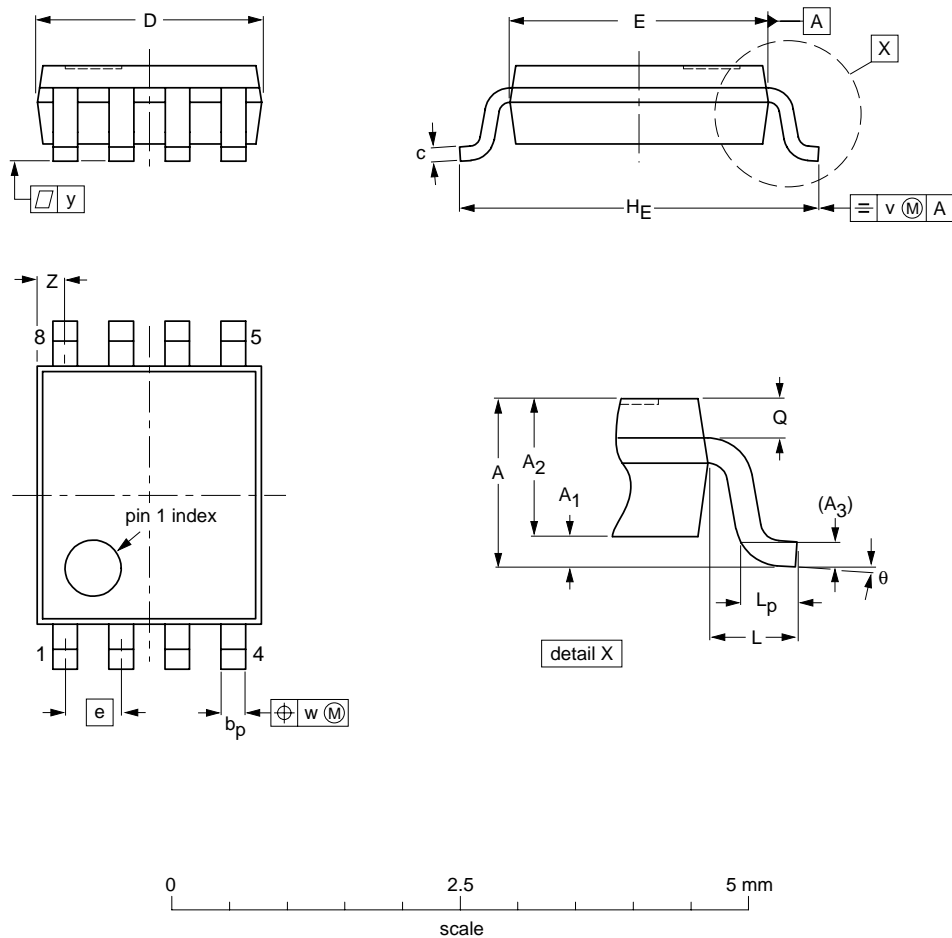

**DIMENSIONS (mm are the original dimensions)**

UNIT	A max.	A <sub>1</sub>	A <sub>2</sub>	A <sub>3</sub>	b <sub>p</sub>	c	D <sup>(1)</sup>	E <sup>(2)</sup>	e	H <sub>E</sub>	L	L <sub>p</sub>	Q	v	w	y	Z <sup>(1)</sup>	θ
mm	1	0.15 0.00	0.85 0.60	0.12	0.27 0.17	0.23 0.08	2.1 1.9	2.4 2.2	0.5	3.2 3.0	0.4	0.40 0.15	0.21 0.19	0.2	0.13	0.1	0.4 0.1	8° 0°

**Notes**

1. Plastic or metal protrusions of 0.15 mm maximum per side are not included.
2. Plastic or metal protrusions of 0.25 mm maximum per side are not included.

OUTLINE VERSION	REFERENCES				EUROPEAN PROJECTION	ISSUE DATE
	IEC	JEDEC	JEITA			
SOT765-1		MO-187				02-06-07

## Inverter

## 74HC3GU04

## DATA SHEET STATUS

LEVEL	DATA SHEET STATUS <sup>(1)</sup>	PRODUCT STATUS <sup>(2)(3)</sup>	DEFINITION
I	Objective data	Development	This data sheet contains data from the objective specification for product development. Philips Semiconductors reserves the right to change the specification in any manner without notice.
II	Preliminary data	Qualification	This data sheet contains data from the preliminary specification. Supplementary data will be published at a later date. Philips Semiconductors reserves the right to change the specification without notice, in order to improve the design and supply the best possible product.
III	Product data	Production	This data sheet contains data from the product specification. Philips Semiconductors reserves the right to make changes at any time in order to improve the design, manufacturing and supply. Relevant changes will be communicated via a Customer Product/Process Change Notification (CPCN).

## Notes

1. Please consult the most recently issued data sheet before initiating or completing a design.
2. The product status of the device(s) described in this data sheet may have changed since this data sheet was published. The latest information is available on the Internet at URL <http://www.semiconductors.philips.com>.
3. For data sheets describing multiple type numbers, the highest-level product status determines the data sheet status.

## DEFINITIONS

**Short-form specification** — The data in a short-form specification is extracted from a full data sheet with the same type number and title. For detailed information see the relevant data sheet or data handbook.

**Limiting values definition** — Limiting values given are in accordance with the Absolute Maximum Rating System (IEC 60134). Stress above one or more of the limiting values may cause permanent damage to the device. These are stress ratings only and operation of the device at these or at any other conditions above those given in the Characteristics sections of the specification is not implied. Exposure to limiting values for extended periods may affect device reliability.

**Application information** — Applications that are described herein for any of these products are for illustrative purposes only. Philips Semiconductors make no representation or warranty that such applications will be suitable for the specified use without further testing or modification.

## DISCLAIMERS

**Life support applications** — These products are not designed for use in life support appliances, devices, or systems where malfunction of these products can reasonably be expected to result in personal injury. Philips Semiconductors customers using or selling these products for use in such applications do so at their own risk and agree to fully indemnify Philips Semiconductors for any damages resulting from such application.

**Right to make changes** — Philips Semiconductors reserves the right to make changes in the products - including circuits, standard cells, and/or software - described or contained herein in order to improve design and/or performance. When the product is in full production (status 'Production'), relevant changes will be communicated via a Customer Product/Process Change Notification (CPCN). Philips Semiconductors assumes no responsibility or liability for the use of any of these products, conveys no licence or title under any patent, copyright, or mask work right to these products, and makes no representations or warranties that these products are free from patent, copyright, or mask work right infringement, unless otherwise specified.

# ***Philips Semiconductors – a worldwide company***

## **Contact information**

For additional information please visit <http://www.semiconductors.philips.com>. Fax: +31 40 27 24825

For sales offices addresses send e-mail to: [sales.addresses@www.semiconductors.philips.com](mailto:sales.addresses@www.semiconductors.philips.com).

© Koninklijke Philips Electronics N.V. 2003

SCA75

All rights are reserved. Reproduction in whole or in part is prohibited without the prior written consent of the copyright owner.

The information presented in this document does not form part of any quotation or contract, is believed to be accurate and reliable and may be changed without notice. No liability will be accepted by the publisher for any consequence of its use. Publication thereof does not convey nor imply any license under patent- or other industrial or intellectual property rights.

Printed in The Netherlands

R44/02/pp14

Date of release: 2003 Nov 26

Document order number: 9397 750 12345

*Let's make things better.*

**Philips  
Semiconductors**



**PHILIPS**



LittleDiode supplies new, hard to find or obsolete electronic components and semiconductors all over the world.

With over two million different components listed you are sure to find the part you need.

Feel free to visit us today at our online store:

[LittleDiode.com](http://LittleDiode.com)

Looking forward to providing you with the best possible service.