

DATA SHEET

74HC1G32
74HCT1G32
2-input OR gate

Product specification
File under Integrated Circuits, IC06

1997 Dec 16

2-input OR gate

74HC1G32
74HCT1G32

FEATURES

- Wide operating voltage : 2.0 to 6.0 V
- Symmetrical output impedance
- High noise immunity
- Low power dissipation
- Balanced propagation delays
- Very small 5 pins package
- Output capability : standard

DESCRIPTION

The 74HC1G/HCT1G32 is a highspeed Si-gate CMOS device.

The 74HC1G/HCT1G32 provides the 2-input OR function. The standard output currents are $\frac{1}{2}$ compared to the 74HC/HCT32.

FUNCTION TABLE

INPUTS		OUTPUT
inA	inB	outY
L	L	L
L	H	H
H	L	H
H	H	H

H = HIGH voltage level

L = LOW voltage level

QUICK REFERENCE DATA

GND = 0 V; $T_{amb} = 25\text{ }^{\circ}\text{C}$; $t_r = t_f \leq 6.0\text{ ns}$

SYMBOL	PARAMETER	CONDITIONS	TYPICAL		UNIT
			HC1G	HCT1G	
t_{PHL}/t_{PLH}	propagation delay inA, inB to outY	$C_L = 15\text{ pF}$ $V_{CC} = 5\text{ V}$	8	10	ns
C_I	input capacitance		1.5	1.5	pF
C_{PD}	power dissipation capacitance	notes 1 and 2	19	20	pF

Notes

1. C_{PD} is used to determine the dynamic power dissipation (P_D in μW).
 $P_D = C_{PD} \times V_{CC}^2 \times f_i + \sum (C_L \times V_{CC}^2 \times f_o)$ where:
 f_i = input frequency in MHz;
 f_o = output frequency in MHz;
 C_L = output load capacitance in pF;
 V_{CC} = supply voltage in V;
 $\sum (C_L \times V_{CC}^2 \times f_o)$ = sum of outputs.
2. For HC1G the condition is $V_I = \text{GND to } V_{CC}$.
 For HCT1G the condition is $V_I = \text{GND to } V_{CC} - 1.5\text{ V}$.

PIN DESCRIPTION

PIN NO.	SYMBOL	NAME AND FUNCTION
1, 2	inB, inA	data inputs
3	GND	ground (0 V)
4	outY	data output
5	V_{CC}	positive supply voltage

2-input OR gate

74HC1G32
74HCT1G32

ORDERING AND PACKAGE INFORMATION

OUTSIDE NORTH AMERICA	NORTH AMERICA	PACKAGES					
		TEMPERATURE RANGE	PINS	PACKAGE	MATERIAL	CODE	MARKING
74HC1G32GW		-40 °C to +125 °C	5	SC88A	plastic	SOT353	HG
74HCT1G32GW			5	SC88A	plastic	SOT353	TG

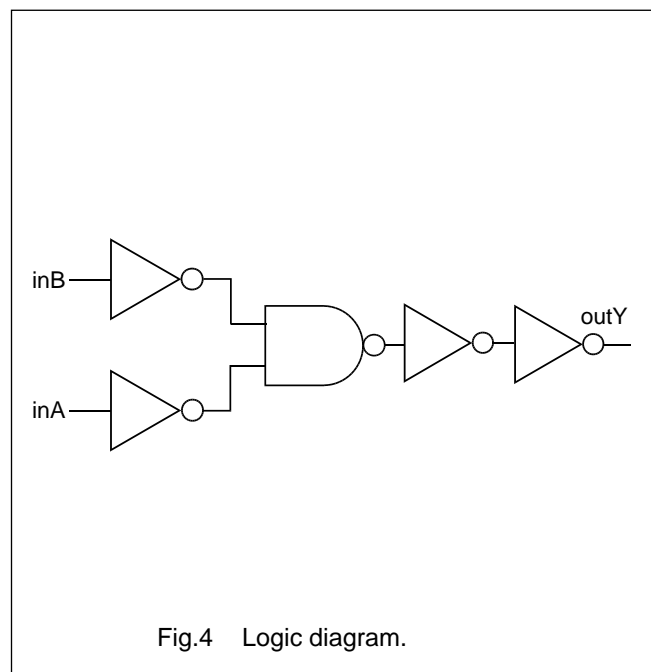
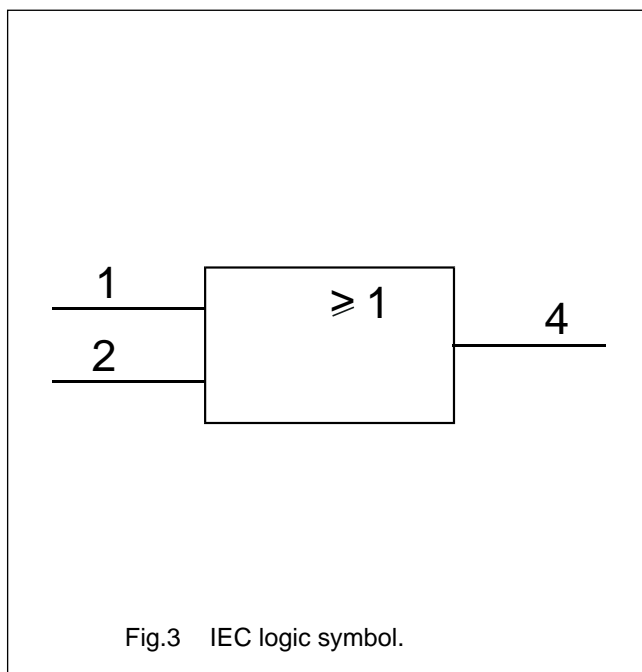
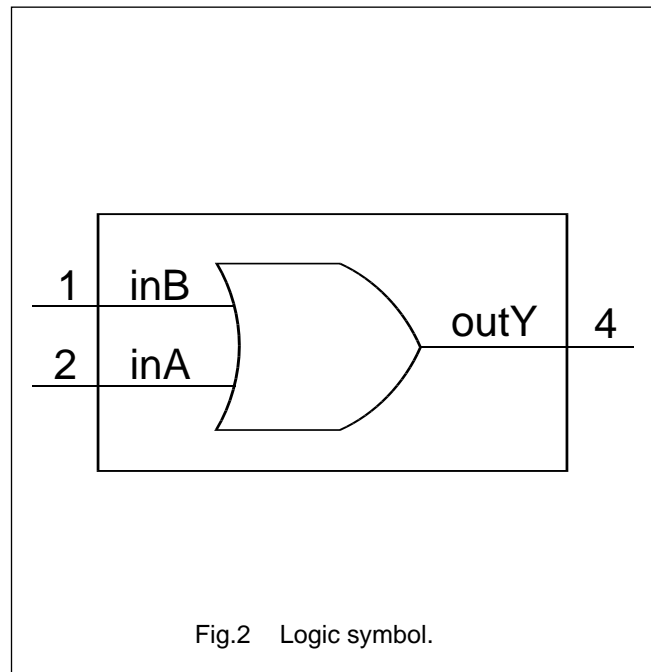
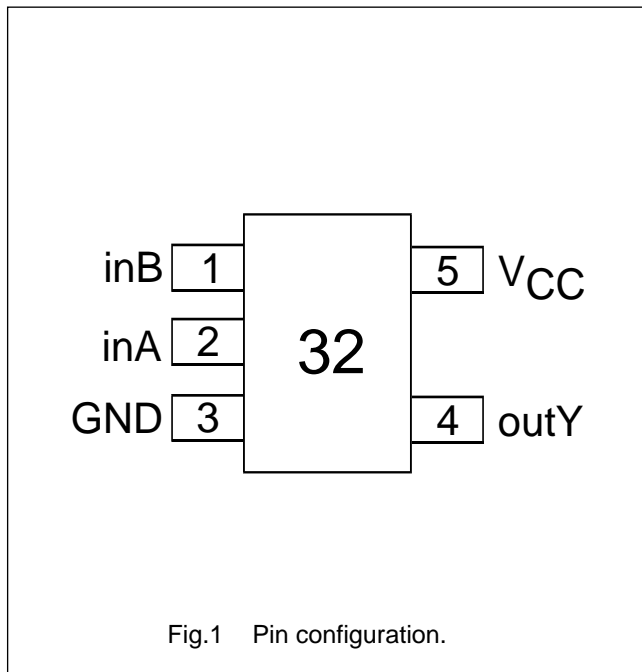

2-input OR gate

74HC1G32
74HCT1G32

RECOMMENDED OPERATING CONDITIONS

SYMBOL	PARAMETER	74HC1G			74HCT1G			UNIT	CONDITIONS
		MIN.	TYP.	MAX.	MIN.	TYP.	MAX.		
V_{CC}	DC supply voltage	2.0	5.0	6.0	4.5	5.0	5.5	V	
V_I	input voltage	0	–	V_{CC}	0	–	V_{CC}	V	
V_O	output voltage	0	–	V_{CC}	0	–	V_{CC}	V	
T_{amb}	operating ambient temperature range	–40	25	+125	–40	25	+125	°C	see DC and AC characteristics per device
t_r, t_f	input rise and fall times except for Schmitt-trigger inputs	–	–	1000	–	–	–	ns	$V_{CC} = 2.0\text{ V}$
		–	–	500	–	–	500		$V_{CC} = 4.5\text{ V}$
		–	–	400	–	–	–		$V_{CC} = 6.0\text{ V}$

ABSOLUTE MAXIMUM RATINGS

Limiting values is accordance with the Absolute Maximum Rating System (IEC 134).

Voltages are referenced to GND (ground = 0 V)

SYMBOL	PARAMETER	CONDITIONS	MIN.	MAX.	UNIT
V_{CC}	DC supply voltage		–0.5	+7.0	V
$\pm I_{IK}$	DC input diode current	$V_I < -0.5$ or $V_I > V_{CC} + 0.5\text{ V}$	–	20	mA
$\pm I_{OK}$	DC output diode current	$V_O < -0.5$ or $V_O > V_{CC} + 0.5\text{ V}$	–	20	mA
$\pm I_O$	DC output source or sink current standard outputs	$-0.5\text{ V} < V_O < V_{CC} + 0.5\text{ V}$	–	12.5	mA
$\pm I_{CC}$	DC V_{CC} or GND current for types with standard outputs		–	25	mA
T_{stg}	storage temperature range		–65	+150	°C
P_D	power dissipation per package 5 pins plastic SC88A	for temperature range: – 40 to + 125 °C above +55 °C derate linearly with 2.5 mW/K	–	200	mW

Notes

- Stresses beyond those listed may cause permanent damage to the device. These are stress rating only and functional operation of the device at these or any other conditions beyond those under 'recommended operating conditions' is not implied. Exposure to absolute maximum rated conditions for extended periods may affect device reliability.
- The input and output voltage ratings may be exceeded if the input and output current ratings are observed.

2-input OR gate

74HC1G32
74HCT1G32**DC CHARACTERISTICS FOR THE 74HC1G**

Over recommended operating conditions.

Voltage are referenced to GND (ground = 0 V)

SYMBOL	PARAMETER	T_{amb} (°C)					UNIT	TEST CONDITIONS	
		-40 to +85			-40 to +125			V_{CC} (V)	OTHER
		MIN.	TYP. ⁽¹⁾	MAX.	MIN.	MAX.			
V_{IH}	HIGH level input voltage	1.5	1.2	–	1.5	–	V	2.0	
		3.15	2.4	–	3.15	–		4.5	
		4.2	3.2	–	4.2	–		6.0	
V_{IL}	LOW level input voltage	–	0.8	0.5	–	0.5	V	2.0	
		–	2.1	1.35	–	1.35		4.5	
		–	2.8	1.8	–	1.8		6.0	
V_{OH}	HIGH level output voltage; all outputs	1.9	2.0	–	1.9	–	V	2.0	$V_I = V_{IH}$ or V_{IL} , $-I_O = 20 \mu A$
		4.4	4.5	–	4.4	–		4.5	
		5.9	6.0	–	5.9	–		6.0	
V_{OH}	HIGH level output voltage; standard outputs	4.13	4.32	–	3.7	–	V	4.5	$V_I = V_{IH}$ or V_{IL} , $-I_O = 2.0 \text{ mA}$
		5.63	5.81	–	5.2	–		6.0	$V_I = V_{IH}$ or V_{IL} , $-I_O = 2.6 \text{ mA}$
V_{OL}	LOW level output voltage; all outputs	–	0	0.1	–	0.1	V	2.0	$V_I = V_{IH}$ or V_{IL} , $I_O = 20 \mu A$
		–	0	0.1	–	0.1		4.5	
		–	0	0.1	–	0.1		6.0	
V_{OL}	LOW level output voltage; standard outputs	–	0.15	0.33	–	0.4	V	4.5	$V_I = V_{IH}$ or V_{IL} , $I_O = 2.0 \text{ mA}$
		–	0.16	0.33	–	0.4		6.0	$V_I = V_{IH}$ or V_{IL} , $I_O = 2.6 \text{ mA}$
I_I	input leakage current	–	–	1.0	–	1.0	μA	6.0	$V_I = V_{CC}$ or GND
I_{CC}	Quiescent supply current	–	–	10	–	20	μA	6.0	$V_I = V_{CC}$ or GND, $I_O = 0$

Note

1. All typical values are measured at $T_{amb} = 25 \text{ }^\circ\text{C}$.

2-input OR gate

74HC1G32
74HCT1G32**DC CHARACTERISTICS FOR THE 74HCT1G**

Over recommended operating conditions.

Voltage are referenced to GND (ground = 0 V.)

SYMBOL	PARAMETER	T_{amb} (°C)					UNIT	TEST CONDITIONS	
		-40 to +85			-40 to +125			V_{CC} (V)	OTHER
		MIN.	TYP. ⁽¹⁾	MAX.	MIN.	MAX.			
V_{IH}	HIGH level input voltage	2.0	1.6	–	2.0	–	V	4.5 to 5.5	
V_{IL}	LOW level input voltage	–	1.2	0.8	–	0.8	V	4.5 to 5.5	
V_{OH}	HIGH level output voltage; all outputs	4.4	4.5	–	4.4	–	V	4.5	$V_I = V_{IH}$ or V_{IL} , $-I_O = 20 \mu A$
V_{OH}	HIGH level output voltage; standard outputs	4.13	4.32	–	3.7	–	V	4.5	$V_I = V_{IH}$ or V_{IL} , $-I_O = 2.0 \text{ mA}$
V_{OL}	LOW level output voltage; all outputs	–	0	0.1	–	0.1	V	4.5	$V_I = V_{IH}$ or V_{IL} , $I_O = 20 \mu A$
V_{OL}	LOW level output voltage; standard outputs	–	0.15	0.33	–	0.4	V	4.5	$V_I = V_{IH}$ or V_{IL} , $I_O = 2.0 \text{ mA}$
I_I	input leakage current	–	–	1.0	–	1.0	μA	5.5	$V_I = V_{CC}$ or GND
I_{CC}	Quiescent supply current	–	–	10.0	–	20	μA	5.5	$V_I = V_{CC}$ or GND, $I_O = 0$
ΔI_{CC}	Additional supply current per input	–	–	500	–	850	μA	4.5 to 5.5	$V_I = V_{CC} - 2.1$, $I_O = 0$

Note1. All typical values are measured at $T_{amb} = 25 \text{ }^\circ\text{C}$.

2-input OR gate

74HC1G32
74HCT1G32**AC CHARACTERISTICS FOR 74HC1G32**GND = 0 V; $t_r = t_f \leq 6.0$ ns; CL = 50 pF

SYMBOL	PARAMETER	T_{amb} (°C)					UNIT	TEST CONDITIONS	
		-40 to +85			-40 to +125			V_{CC} (V)	WAVEFORMS
		MIN.	TYP. ⁽¹⁾	MAX.	MIN.	MAX.			
t_{PHL}/t_{PLH}	propagation delay inA, inB to outY	–	18	115	–	135	ns	2.0	see Fig.5 and Fig.6
		–	8	23	–	27		4.5	
		–	7	20	–	23		6.0	

Note

- All typical values are measured at $T_{amb} = 25$ °C.

AC CHARACTERISTICS FOR 74HCT1G32GND = 0 V; $t_r = t_f \leq 6.0$ ns; CL = 50 pF

SYMBOL	PARAMETER	T_{amb} (°C)					UNIT	TEST CONDITIONS	
		-40 to +85			-40 to +125			V_{CC} (V)	WAVEFORMS
		MIN.	TYP. ⁽¹⁾	MAX.	MIN.	MAX.			
t_{PHL}/t_{PLH}	propagation delay inA, inB to outY	–	10	24	–	27	ns	4.5	see Fig.5 and Fig.6

Note

- All typical values are measured at $T_{amb} = 25$ °C.

2-input OR gate

74HC1G32
74HCT1G32

AC WAVEFORMS

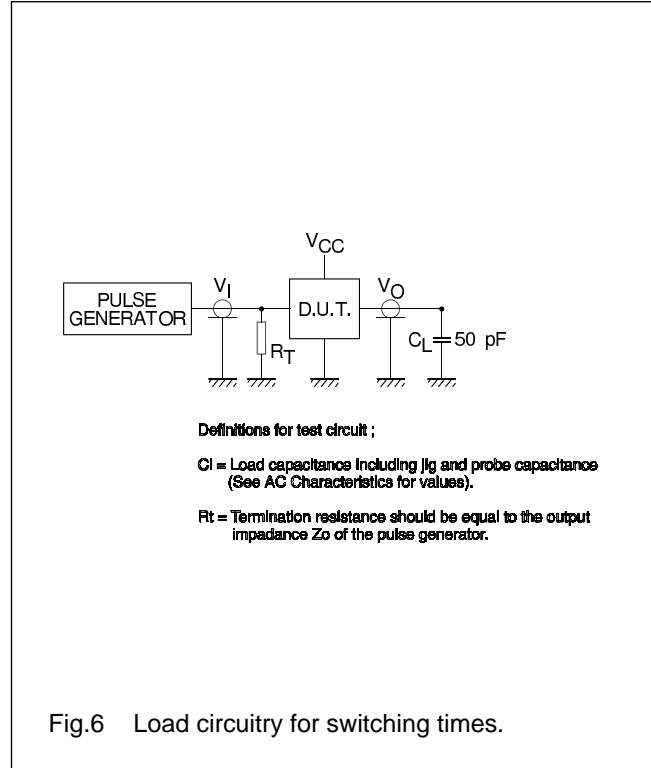
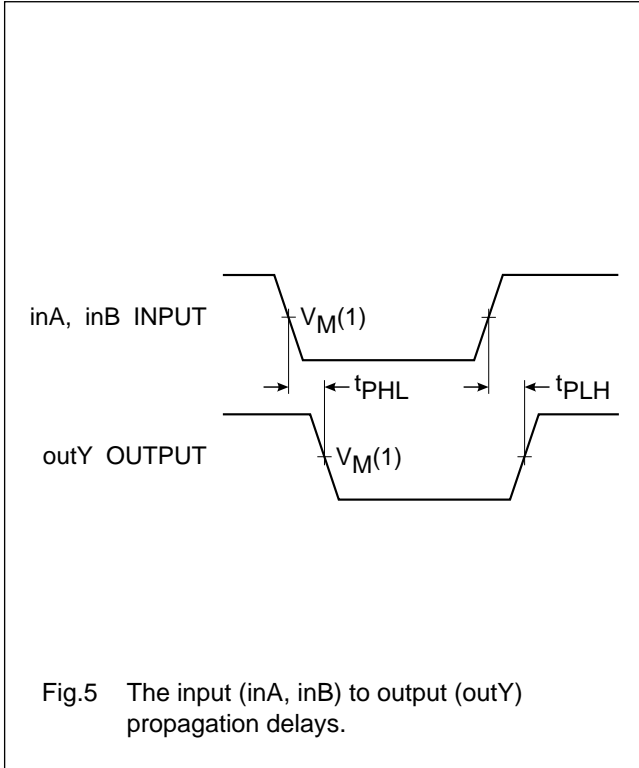

2-input OR gate

74HC1G32
74HCT1G32

PACKAGE OUTLINES

Plastic surface mounted package; 5 leads

SOT353

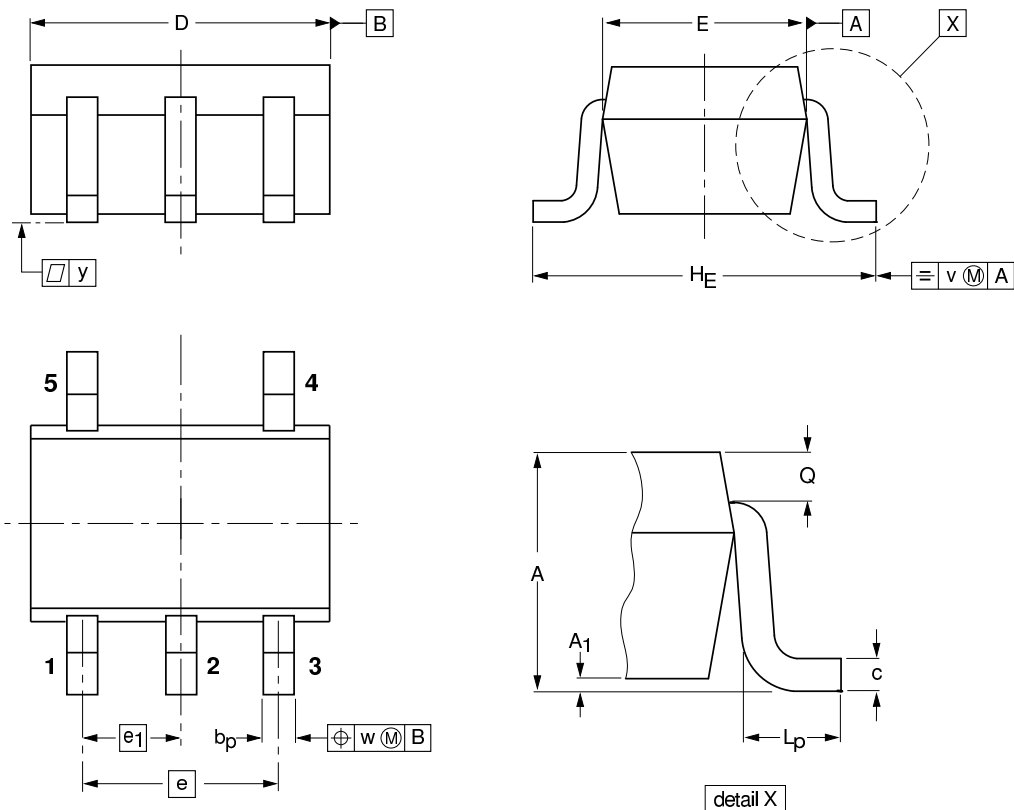

DIMENSIONS (mm are the original dimensions)

UNIT	A	A ₁ max	bp	c	D	E ⁽²⁾	e	e ₁	H _E	L _p	Q	v	w	y
mm	1.1 0.8	0.1	0.30 0.20	0.25 0.10	2.2 1.8	1.35 1.15	1.3	0.65	2.2 2.0	0.45 0.15	0.25 0.15	0.2	0.2	0.1

OUTLINE VERSION	REFERENCES				EUROPEAN PROJECTION	ISSUE DATE
	IEC	JEDEC	EIAJ			
SOT353			SC-88A			97-02-28

2-input OR gate

74HC1G32
74HCT1G32

SOLDERING

Introduction

There is no soldering method that is ideal for all IC packages. Wave soldering is often preferred when through-hole and surface mounted components are mixed on one printed-circuit board. However, wave soldering is not always suitable for surface mounted ICs, or for printed-circuits with high population densities. In these situations reflow soldering is often used.

This text gives a very brief insight to a complex technology. A more in-depth account of soldering ICs can be found in our "IC Package Databook" (order code 9398 652 90011).

Reflow soldering

Reflow soldering techniques are suitable for all SO packages.

Reflow soldering requires solder paste (a suspension of fine solder particles, flux and binding agent) to be applied to the printed-circuit board by screen printing, stencilling or pressure-syringe dispensing before package placement.

Several techniques exist for reflowing; for example, thermal conduction by heated belt. Dwell times vary between 50 and 300 seconds depending on heating method. Typical reflow temperatures range from 215 to 250 °C.

Preheating is necessary to dry the paste and evaporate the binding agent. Preheating duration: 45 minutes at 45 °C.

Wave soldering

Wave soldering techniques can be used for all SO packages if the following conditions are observed:

- A double-wave (a turbulent wave with high upward pressure followed by a smooth laminar wave) soldering technique should be used.
- The longitudinal axis of the package footprint must be parallel to the solder flow.
- The package footprint must incorporate solder thieves at the downstream end.

During placement and before soldering, the package must be fixed with a droplet of adhesive. The adhesive can be applied by screen printing, pin transfer or syringe dispensing. The package can be soldered after the adhesive is cured.

Maximum permissible solder temperature is 260 °C, and maximum duration of package immersion in solder is 10 seconds, if cooled to less than 150 °C within 6 seconds. Typical dwell time is 4 seconds at 250 °C.

A mildly-activated flux will eliminate the need for removal of corrosive residues in most applications.

Repairing soldered joints

Fix the component by first soldering two diagonally- opposite end leads. Use only a low voltage soldering iron (less than 24 V) applied to the flat part of the lead. Contact time must be limited to 10 seconds at up to 300 °C. When using a dedicated tool, all other leads can be soldered in one operation within 2 to 5 seconds between 270 and 320 °C.

2-input OR gate

74HC1G32
74HCT1G32**DEFINITIONS**

Data sheet status	
Objective specification	This data sheet contains target or goal specifications for product development.
Preliminary specification	This data sheet contains preliminary data; supplementary data may be published later.
Product specification	This data sheet contains final product specifications.
Limiting values	
Limiting values given are in accordance with the Absolute Maximum Rating System (IEC 134). Stress above one or more of the limiting values may cause permanent damage to the device. These are stress ratings only and operation of the device at these or at any other conditions above those given in the Characteristics sections of the specification is not implied. Exposure to limiting values for extended periods may affect device reliability.	
Application information	
Where application information is given, it is advisory and does not form part of the specification.	

LIFE SUPPORT APPLICATIONS

These products are not designed for use in life support appliances, devices, or systems where malfunction of these products can reasonably be expected to result in personal injury. Philips customers using or selling these products for use in such applications do so at their own risk and agree to fully indemnify Philips for any damages resulting from such improper use or sale.

Philips Semiconductors – a worldwide company

Argentina: see South America

Australia: 34 Waterloo Road, NORTH RYDE, NSW 2113,
Tel. +61 2 9805 4455, Fax. +61 2 9805 4466

Austria: Computerstr. 6, A-1101 WIEN, P.O. Box 213, Tel. +43 160 1010,
Fax. +43 160 101 1210

Belarus: Hotel Minsk Business Center, Bld. 3, r. 1211, Volodarski Str. 6,
220050 MINSK, Tel. +375 172 200 733, Fax. +375 172 200 773

Belgium: see The Netherlands

Brazil: see South America

Bulgaria: Philips Bulgaria Ltd., Energoproject, 15th floor,
51 James Bouchier Blvd., 1407 SOFIA,
Tel. +359 2 689 211, Fax. +359 2 689 102

Canada: PHILIPS SEMICONDUCTORS/COMPONENTS,
Tel. +1 800 234 7381

China/Hong Kong: 501 Hong Kong Industrial Technology Centre,
72 Tat Chee Avenue, Kowloon Tong, HONG KONG,
Tel. +852 2319 7888, Fax. +852 2319 7700

Colombia: see South America

Czech Republic: see Austria

Denmark: Prags Boulevard 80, PB 1919, DK-2300 COPENHAGEN S,
Tel. +45 32 88 2636, Fax. +45 31 57 0044

Finland: Sinikalliontie 3, FIN-02630 ESPOO,
Tel. +358 9 615800, Fax. +358 9 61580920

France: 4 Rue du Port-aux-Vins, BP317, 92156 SURESNES Cedex,
Tel. +33 1 40 99 6161, Fax. +33 1 40 99 6427

Germany: Hammerbrookstraße 69, D-20097 HAMBURG,
Tel. +49 40 23 53 60, Fax. +49 40 23 536 300

Greece: No. 15, 25th March Street, GR 17778 TAVROS/ATHENS,
Tel. +30 1 4894 339/239, Fax. +30 1 4814 240

Hungary: see Austria

India: Philips INDIA Ltd, Band Box Building, 2nd floor,
254-D, Dr. Annie Besant Road, Worli, MUMBAI 400 025,
Tel. +91 22 493 8541, Fax. +91 22 493 0966

Indonesia: see Singapore

Ireland: Newstead, Clonskeagh, DUBLIN 14,
Tel. +353 1 7640 000, Fax. +353 1 7640 200

Israel: RAPAC Electronics, 7 Kehilat Saloniki St, PO Box 18053,
TEL AVIV 61180, Tel. +972 3 645 0444, Fax. +972 3 649 1007

Italy: PHILIPS SEMICONDUCTORS, Piazza IV Novembre 3,
20124 MILANO, Tel. +39 2 6752 2531, Fax. +39 2 6752 2557

Japan: Philips Bldg 13-37, Kohnan 2-chome, Minato-ku, TOKYO 108,
Tel. +81 3 3740 5130, Fax. +81 3 3740 5077

Korea: Philips House, 260-199 Itaewon-dong, Yongsan-ku, SEOUL,
Tel. +82 2 709 1412, Fax. +82 2 709 1415

Malaysia: No. 76 Jalan Universiti, 46200 PETALING JAYA, SELANGOR,
Tel. +60 3 750 5214, Fax. +60 3 757 4880

Mexico: 5900 Gateway East, Suite 200, EL PASO, TEXAS 79905,
Tel. +9-5 800 234 7381

Middle East: see Italy

Netherlands: Postbus 90050, 5600 PB EINDHOVEN, Bldg. VB,
Tel. +31 40 27 82785, Fax. +31 40 27 88399

New Zealand: 2 Wagener Place, C.P.O. Box 1041, AUCKLAND,
Tel. +64 9 849 4160, Fax. +64 9 849 7811

Norway: Box 1, Manglerud 0612, OSLO,
Tel. +47 22 74 8000, Fax. +47 22 74 8341

Philippines: Philips Semiconductors Philippines Inc.,
106 Valero St. Salcedo Village, P.O. Box 2108 MCC, MAKATI,
Metro MANILA, Tel. +63 2 816 6380, Fax. +63 2 817 3474

Poland: Ul. Lukiska 10, PL 04-123 WARSZAWA,
Tel. +48 22 612 2831, Fax. +48 22 612 2327

Portugal: see Spain

Romania: see Italy

Russia: Philips Russia, Ul. Usatcheva 35A, 119048 MOSCOW,
Tel. +7 095 755 6918, Fax. +7 095 755 6919

Singapore: Lorong 1, Toa Payoh, SINGAPORE 1231,
Tel. +65 350 2538, Fax. +65 251 6500

Slovakia: see Austria

Slovenia: see Italy

South Africa: S.A. PHILIPS Pty Ltd., 195-215 Main Road Martindale,
2092 JOHANNESBURG, P.O. Box 7430 Johannesburg 2000,
Tel. +27 11 470 5911, Fax. +27 11 470 5494

South America: Rua do Rocio 220, 5th floor, Suite 51,
04552-903 São Paulo, SÃO PAULO - SP, Brazil,
Tel. +55 11 821 2333, Fax. +55 11 829 1849

Spain: Balmes 22, 08007 BARCELONA,
Tel. +34 3 301 6312, Fax. +34 3 301 4107

Sweden: Kottbygatan 7, Akalla, S-16485 STOCKHOLM,
Tel. +46 8 632 2000, Fax. +46 8 632 2745

Switzerland: Allmendstrasse 140, CH-8027 ZÜRICH,
Tel. +41 1 488 2686, Fax. +41 1 481 7730

Taiwan: Philips Semiconductors, 6F, No. 96, Chien Kuo N. Rd., Sec. 1,
TAIPEI, Taiwan Tel. +886 2 2134 2865, Fax. +886 2 2134 2874

Thailand: PHILIPS ELECTRONICS (THAILAND) Ltd.,
209/2 Sanpavuth-Bangna Road Prakanong, BANGKOK 10260,
Tel. +66 2 745 4090, Fax. +66 2 398 0793

Turkey: Talatpasa Cad. No. 5, 80640 GÜLTEPE/ISTANBUL,
Tel. +90 212 279 2770, Fax. +90 212 282 6707

Ukraine: PHILIPS UKRAINE, 4 Patrice Lumumba str., Building B, Floor 7,
252042 KIEV, Tel. +380 44 264 2776, Fax. +380 44 268 0461

United Kingdom: Philips Semiconductors Ltd., 276 Bath Road, Hayes,
MIDDLESEX UB3 5BX, Tel. +44 181 730 5000, Fax. +44 181 754 8421

United States: 811 East Arques Avenue, SUNNYVALE, CA 94088-3409,
Tel. +1 800 234 7381

Uruguay: see South America

Vietnam: see Singapore

Yugoslavia: PHILIPS, Trg N. Pasica 5/v, 11000 BEOGRAD,
Tel. +381 11 625 344, Fax. +381 11 635 777

For all other countries apply to: Philips Semiconductors, Marketing & Sales Communications,
Building BE-p, P.O. Box 218, 5600 MD EINDHOVEN, The Netherlands, Fax. +31 40 27 24825

Internet: <http://www.semiconductors.philips.com>

© Philips Electronics N.V. 1997

SCA55

All rights are reserved. Reproduction in whole or in part is prohibited without the prior written consent of the copyright owner.

The information presented in this document does not form part of any quotation or contract, is believed to be accurate and reliable and may be changed without notice. No liability will be accepted by the publisher for any consequence of its use. Publication thereof does not convey nor imply any license under patent- or other industrial or intellectual property rights.

Printed in The Netherlands

budgetnum/printrun/ed/pp12

Date of release: 1997 Dec 16

Document order number: 9397 nnn nnnnn

Let's make things better.

**Philips
Semiconductors**



PHILIPS



LittleDiode supplies new, hard to find or obsolete electronic components and semiconductors all over the world.

With over two million different components listed you are sure to find the part you need.

Feel free to visit us today at our online store:

LittleDiode.com

Looking forward to providing you with the best possible service.