

DATA SHEET

FAMILY SPECIFICATIONS HCMOS family characteristics

March 1988

File under Integrated Circuits, IC06

HCMOS family characteristics

FAMILY SPECIFICATIONS

GENERAL

These family specifications cover the common electrical ratings and characteristics of the entire HCMOS 74HC/HCT/HCU family, unless otherwise specified in the individual device data sheet.

INTRODUCTION

The 74HC/HCT/HCU high-speed Si-gate CMOS logic family combines the low power advantages of the HE4000B family with the high speed and drive capability of the low power Schottky TTL (LSTTL).

The family will have the same pin-out as the 74 series and provide the same circuit functions.

In these families are included several HE4000B family circuits which do not have TTL counterparts, and some special circuits.

The basic family of buffered devices, designated as XX74HCXXXXX, will operate at CMOS input logic levels for high noise immunity, negligible typical quiescent supply and input current. It is operated from a power supply of 2 to 6 V.

A subset of the family, designated as XX74HCTXXXXX, with the same features and functions as the "HC-types", will operate at standard TTL power supply voltage ($5\text{ V} \pm 10\%$) and logic input levels (0.8 to 2.0 V) for use as pin-to-pin compatible CMOS replacements to reduce power consumption without loss of speed. These types are also suitable for converted switching from TTL to CMOS.

Another subset, the XX74HCUXXXXX, consists of single-stage unbuffered CMOS compatible devices for application in RC or crystal controlled oscillators and other types of feedback circuits which operate in the linear mode.

HANDLING MOS DEVICES

Inputs and outputs are protected against electrostatic effects in a wide variety of device-handling situations. However, to be totally safe, it is desirable to take handling precautions into account (see also "HANDLING PRECAUTIONS").

RECOMMENDED OPERATING CONDITIONS FOR 74HC/HCT

SYMBOL	PARAMETER	74HC			74HCT			UNIT	CONDITIONS
		min.	typ.	max.	min.	typ.	max.		
V_{CC}	DC supply voltage	2.0	5.0	6.0	4.5	5.0	5.5	V	
V_I	DC input voltage range	0		V_{CC}	0		V_{CC}	V	
V_O	DC output voltage range	0		V_{CC}	0		V_{CC}	V	
T_{amb}	operating ambient temperature range	-40		+85	-40		+85	°C	see DC and AC CHAR. per device
T_{amb}	operating ambient temperature range	-40		+125	-40		+125	°C	
t_r, t_f	input rise and fall times except for Schmitt-trigger inputs		6.0	1000 500 400		6.0	500	ns	$V_{CC} = 2.0\text{ V}$ $V_{CC} = 4.5\text{ V}$ $V_{CC} = 6.0\text{ V}$

Note

- For analog switches, e.g. "4016", "4051 series", "4351 series", "4066" and "4067", the specified maximum operating supply voltage is 10 V.

HCMOS family characteristics

FAMILY SPECIFICATIONS

RECOMMENDED OPERATING CONDITIONS FOR 74HCU

SYMBOL	PARAMETER	74HCU			UNIT	CONDITIONS
		min.	typ.	max.		
V_{CC}	DC supply voltage	2.0	5.0	6.0	V	
V_I	DC input voltage range	0		V_{CC}	V	
V_O	DC output voltage range	0		V_{CC}	V	
T_{amb}	operating ambient temperature range	-40		+85	°C	see DC and AC CHAR. per device
T_{amb}	operating ambient temperature range	-40		+125	°C	

RATINGS

Limiting values in accordance with the Absolute Maximum System (IEC 134)

Voltages are referenced to GND (ground = 0 V)

SYMBOL	PARAMETER	MIN.	MAX.	UNIT	CONDITIONS
V_{CC}	DC supply voltage	-0.5	+7	V	
$\pm I_{IK}$	DC input diode current		20	mA	for $V_I < -0.5$ or $V_I > V_{CC} + 0.5$ V
$\pm I_{OK}$	DC output diode current		20	mA	for $V_O < -0.5$ or $V_O > V_{CC} + 0.5$ V
$\pm I_O$	DC output source or sink current				for -0.5 V $< V_O < V_{CC} + 0.5$ V
	standard outputs		25	mA	
	bus driver outputs		35	mA	
$\pm I_{CC}$; $\pm I_{GND}$	DC V_{CC} or GND current for types with:				
	standard outputs		50	mA	
	bus driver outputs		70	mA	
T_{stg}	storage temperature range	-65	+150	°C	
P_{tot}	power dissipation per package				for temperature range: -40 to +125 °C 74HC/HCT/HCU
	plastic DIL		750	mW	above +70 °C: derate linearly with 12 mW/K
	plastic mini-pack (SO)		500	mW	above +70 °C: derate linearly with 8 mW/K

Note

- For analog switches, e.g. "4016", "4051 series", "4351 series", "4066" and "4067", the specified maximum operating supply voltage is 11 V.

HCMOS family characteristics

FAMILY SPECIFICATIONS

DC CHARACTERISTICS FOR 74HC

Voltages are referenced to GND (ground = 0 V)

SYMBOL	PARAMETER	T_{amb} (°C)							UNIT	TEST CONDITIONS		
		74HC								V_{CC} (V)	V_I	OTHER
		+25			-40 to +85		-40 to +125					
		min.	typ.	max.	min.	max.	min.	max.				
V_{IH}	HIGH level input voltage	1.5 3.15 4.2	1.2 2.4 3.2		1.5 3.15 4.2		1.5 3.15 4.2		V	2.0 4.5 6.0		
V_{IL}	LOW level input voltage		0.8 2.1 2.8	0.5 1.35 1.8		0.5 1.35 1.8		0.5 1.35 1.8	V	2.0 4.5 6.0		
V_{OH}	HIGH level output voltage all outputs	1.9 4.4 5.9	2.0 4.5 6.0		1.9 4.4 5.9		1.9 4.4 5.9		V	2.0 4.5 6.0	V_{IH} or V_{IL}	$-I_O = 20 \mu A$ $-I_O = 20 \mu A$ $-I_O = 20 \mu A$
V_{OH}	HIGH level output voltage standard outputs	3.98 5.48	4.32 5.81		3.84 5.34		3.7 5.2		V	4.5 6.0	V_{IH} or V_{IL}	$-I_O = 4.0 \text{ mA}$ $-I_O = 5.2 \text{ mA}$
V_{OH}	HIGH level output voltage bus driver outputs	3.98 5.48	4.32 5.81		3.84 5.34		3.7 5.2		V	4.5 6.0	V_{IH} or V_{IL}	$-I_O = 6.0 \text{ mA}$ $-I_O = 7.8 \text{ mA}$
V_{OL}	LOW level output voltage all outputs		0 0 0	0.1 0.1 0.1		0.1 0.1 0.1		0.1 0.1 0.1	V	2.0 4.5 6.0	V_{IH} or V_{IL}	$I_O = 20 \mu A$ $I_O = 20 \mu A$ $I_O = 20 \mu A$
V_{OL}	LOW level output voltage standard outputs		0.15 0.16	0.26 0.26		0.33 0.33		0.4 0.4	V	4.5 6.0	V_{IH} or V_{IL}	$I_O = 4.0 \text{ mA}$ $I_O = 5.2 \text{ mA}$
V_{OL}	LOW level output voltage bus driver outputs		0.15 0.16	0.26 0.26		0.33 0.33		0.4 0.4	V	4.5 6.0	V_{IH} or V_{IL}	$I_O = 6.0 \text{ mA}$ $I_O = 7.8 \text{ mA}$
$\pm I_I$	input leakage current			0.1		1.0		1.0	μA	6.0	V_{CC} or GND	
$\pm I_{OZ}$	3-state OFF-state current			0.5		5.0		10.0	μA	6.0	V_{IH} or V_{IL}	$V_O = V_{CC}$ or GND
I_{CC}	quiescent supply current											
	SSI			2.0		20.0		40.0	μA	6.0	V_{CC}	$I_O = 0$
	flip-flops			4.0		40.0		80.0		6.0	or GND	$I_O = 0$
	MSI			8.0		80.0		160.0		6.0		$I_O = 0$
	LSI			50.0		500		1000		6.0		$I_O = 0$

HCMOS family characteristics

FAMILY SPECIFICATIONS

DC CHARACTERISTICS FOR 74HCT

Voltages are referenced to GND (ground = 0 V)

SYMBOL	PARAMETER	T _{amb} (°C)							UNIT	TEST CONDITIONS		
		74HCT								V _{CC} (V)	V _I	OTHER
		+25			-40 to +85		-40 to +125					
		min.	typ.	max.	min.	max.	min.	max.				
V _{IH}	HIGH level input voltage	2.0	1.6		2.0		2.0		V	4.5 to 5.5		
V _{IL}	LOW level input voltage		1.2	0.8		0.8		0.8	V	4.5 to 5.5		
V _{OH}	HIGH level output voltage all outputs	4.4	4.5		4.4		4.4		V	4.5	V _{IH} or V _{IL}	-I _O = 20 μA
V _{OH}	HIGH level output voltage standard outputs	3.98	4.32		3.84		3.7		V	4.5	V _{IH} or V _{IL}	-I _O = 4.0 mA
V _{OH}	HIGH level output voltage bus driver outputs	3.98	4.32		3.84		3.7		V	4.5	V _{IH} or V _{IL}	-I _O = 6.0 mA
V _{OL}	LOW level output voltage all outputs		0	0.1		0.1		0.1	V	4.5	V _{IH} or V _{IL}	I _O = 20 μA
V _{OL}	LOW level output voltage standard outputs		0.15	0.26		0.33		0.4	V	4.5	V _{IH} or V _{IL}	I _O = 4.0 mA
V _{OL}	LOW level output voltage bus driver outputs		0.16	0.26		0.33		0.4	V	4.5	V _{IH} or V _{IL}	I _O = 6.0 mA
±I _I	input leakage current			0.1		1.0		1.0	μA	5.5	V _{CC} or GND	
±I _{OZ}	3-state OFF-state current			0.5		5.0		10.0	μA	5.5	V _{IH} or V _{IL}	V _O = V _{CC} or GND per input pin; other inputs at V _{CC} or GND; I _O = 0
I _{CC}	quiescent supply current											
	SSI			2.0		20.0		40.0	μA	5.5	V _{CC} or GND	I _O = 0
	flip-flops			4.0		40.0		80.0		5.5		I _O = 0
	MSI			8.0		80.0		160.0		5.5		I _O = 0
	LSI			50.0		500		1000		5.5		I _O = 0

HCMOS family characteristics

FAMILY SPECIFICATIONS

SYMBOL	PARAMETER	T _{amb} (°C)							UNIT	TEST CONDITIONS		
		74HCT								V _{CC} (V)	V _I	OTHER
		+25			-40 to +85		-40 to +125					
		min.	typ.	max.	min.	max.	min.	max.				
ΔI_{CC}	additional quiescent supply current per input pin for unit load coefficient is 1 (note 1)		100	360		450		490	μA	4.5 to 5.5	V _{CC} -2.1 V	other inputs at V _{CC} or GND; I _O = 0

Note

1. The additional quiescent supply current per input is determined by the ΔI_{CC} unit load, which has to be multiplied by the unit load coefficient as given in the individual data sheets. For dual supply systems the theoretical worst-case (V_I = 2.4 V; V_{CC} = 5.5 V) specification is: ΔI_{CC} = 0.65 mA (typical) and 1.8 mA (maximum) across temperature.

HCMOS family characteristics

FAMILY SPECIFICATIONS

DC CHARACTERISTICS FOR 74HCU

Voltages are referenced to GND (ground = 0 V)

SYMBOL	PARAMETER	T _{amb} (°C)							UNIT	TEST CONDITIONS		
		74HCU								V _{CC} (V)	V _I	OTHER
		+25			-40 to +85		-40 to +125					
		min.	typ.	max.	min.	max.	min.	max.				
V _{IH}	HIGH level input voltage	1.7	1.4		1.7		1.7		V	2.0		
		3.6	2.6		3.6		3.6			4.5		
		4.8	3.4		4.8		4.8			6.0		
V _{IL}	LOW level input voltage		0.6	0.3		0.3		0.3	V	2.0		
			1.9	0.9		0.9		0.9		4.5		
			2.6	1.2		1.2		1.2		6.0		
V _{OH}	HIGH level output voltage	1.8	2.0		1.8		1.8		V	2.0	V _{IH}	-I _O = 20 μA
		4.0	4.5		4.0		4.0			4.5	or	-I _O = 20 μA
		5.5	6.0		5.5		5.5			6.0	V _{IL}	-I _O = 20 μA
V _{OH}	HIGH level output voltage	3.98	4.32		3.84		3.7		V	4.5	V _{CC}	-I _O = 4.0 mA
		5.48	5.81		5.34		5.2			6.0	or	-I _O = 5.2 mA
											GND	
V _{OL}	LOW level output voltage		0	0.2		0.2		0.2	V	2.0	V _{IH}	I _O = 20 μA
			0	0.5		0.5		0.5		4.5	or	I _O = 20 μA
			0	0.5		0.5		0.5		6.0	V _{IL}	I _O = 20 μA
V _{OL}	LOW level output voltage		0.15	0.26		0.33		0.4	V	4.5	V _{CC}	I _O = 4.0 mA
			0.16	0.26		0.33		0.4		6.0	or	I _O = 5.2 mA
											GND	
±I _I	input leakage current			0.1		1.0		1.0	μA	6.0	V _{CC}	
											or	
											GND	
I _{CC}	quiescent supply current SSI			2.0		20.0		40.0	μA	6.0	V _{CC}	I _O = 0
											or	
											GND	

HCMOS family characteristics

FAMILY SPECIFICATIONS

AC CHARACTERISTICS FOR 74HC

GND = 0 V; $t_r = t_f = 6$ ns; $C_L = 50$ pF

SYMBOL	PARAMETER	T_{amb} (°C)						UNIT	TEST CONDITIONS		
		74HC							V_{CC} (V)	WAVEFORMS	
		+25			-40 to +85		-40 to +125				
		min.	typ.	max.	min.	max.	min.				max.
t_{THL} / t_{TLH}	output transition time standard outputs		19	75		95		110	ns	2.0 4.5 6.0	Figs 3 and 4
			7	15		19		22			
			6	13		16		19			
t_{THL} / t_{TLH}	output transition time bus driver outputs		14	60		75		90	ns	2.0 4.5 6.0	Figs 3 and 4
			5	12		15		18			
			4	10		13		15			

AC CHARACTERISTICS FOR 74HCU

GND = 0 V; $t_r = t_f = 6$ ns; $C_L = 50$ pF

SYMBOL	PARAMETER	T_{amb} (°C)						UNIT	TEST CONDITIONS		
		74HCU							V_{CC} (V)	WAVEFORMS	
		+25			-40 to +85		-40 to +125				
		min.	typ.	max.	min.	max.	min.				max.
t_{THL} / t_{TLH}	output transition time		19	75		95		110	ns	2.0 4.5 6.0	Fig.1
			7	15		19		22			
			6	13		16		19			

AC CHARACTERISTICS FOR 74HCT

GND = 0 V; $t_r = t_f = 6$ ns; $C_L = 50$ pF

SYMBOL	PARAMETER	T_{amb} (°C)						UNIT	TEST CONDITIONS		
		74HCT							V_{CC} (V)	WAVEFORMS	
		+25			-40 to +85		-40 to +125				
		min.	typ.	max.	min.	max.	min.				max.
t_{THL} / t_{TLH}	output transition time standard outputs		7	15		19		22	ns	4.5	Figs 8 and 9
t_{THL} / t_{TLH}	output transition time bus driver outputs		5	12		15		18			

HCU TYPES

AC waveforms 74HCU

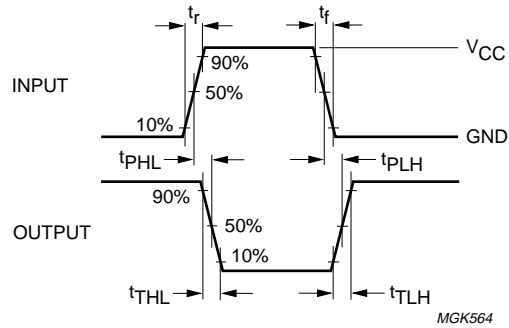
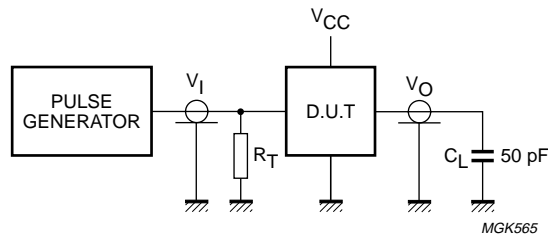

Fig.1 Input rise and fall times, transition times and propagation delays for combinatorial logic ICs.

Test circuit for 74HCU



- C_L = load capacitance including jig and probe capacitance (see AC CHARACTERISTICS for values).
- R_T = termination resistance should be equal to the output impedance Z_o of the pulse generator.

Fig.2 Test circuit.

HC TYPES

AC waveforms 74HC

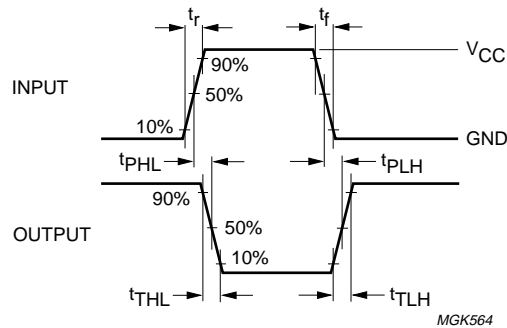
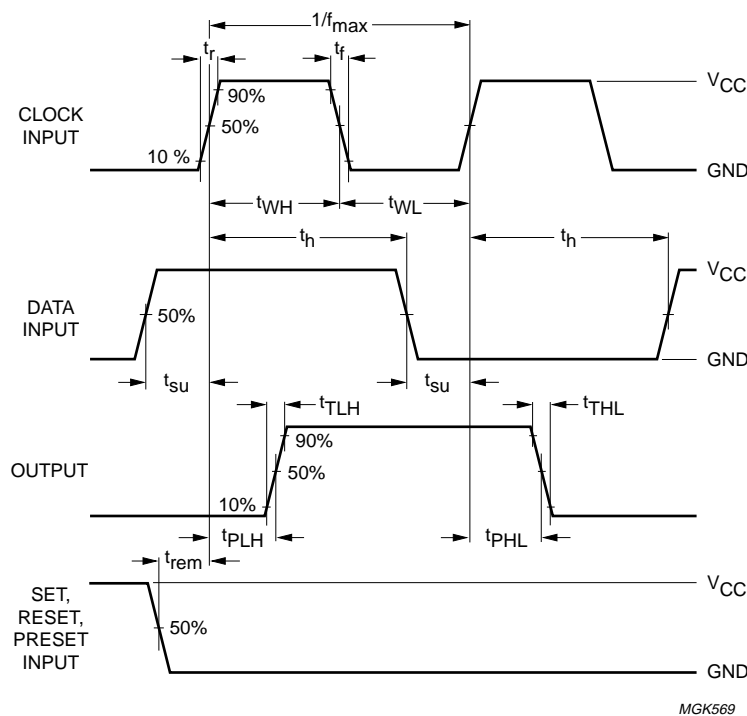

Fig.3 Input rise and fall times, transition times and propagation delays for combinatorial logic ICs.

AC waveforms 74HC



- (1) In Fig.4 the active transition of the clock is going from LOW-to-HIGH and the active level of the forcing signals (SET, RESET and PRESET) is HIGH. The actual direction of the transition of the clock input and the actual active levels of the forcing signals are specified in the individual device data sheet.
- (2) For AC measurements: $t_r = t_f = 6$ ns; when measuring f_{max} , there is no constraint on t_r , t_f with 50% duty factor.

Fig.4 Set-up times, hold times, removal times, propagation delays and the maximum clock pulse frequency for sequential logic ICs.

Test circuit for 74HC

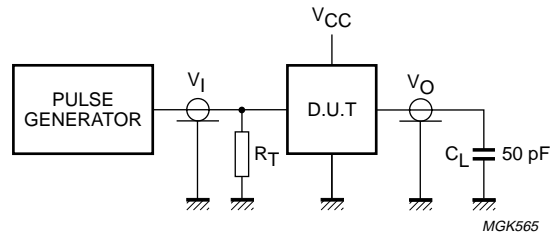

- C_L = load capacitance including jig and probe capacitance (see AC CHARACTERISTICS for values).
- R_T = termination resistance should be equal to the output impedance Z_o of the pulse generator.

Fig.5 Test circuit.

AC waveforms 74HC (continued)

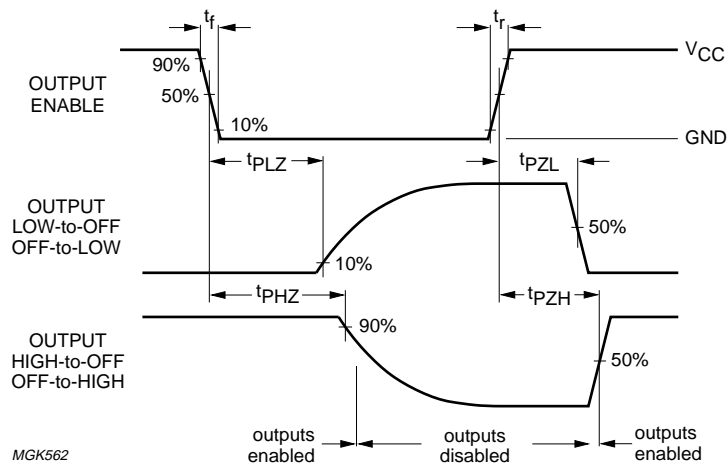
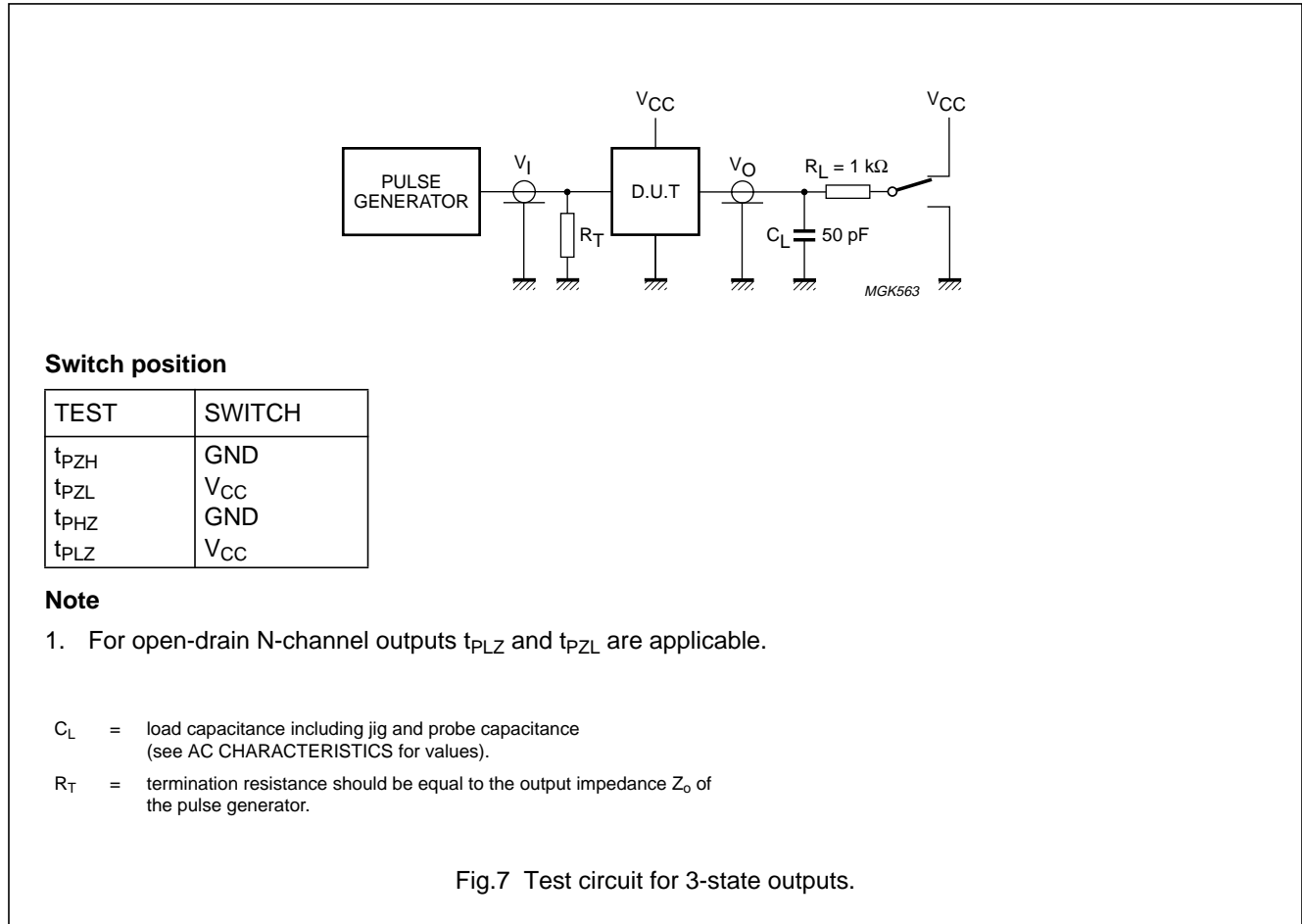

Fig.6 Propagation delays of 3-state outputs.

Test circuit for 74HC



HCT TYPES

AC waveforms 74HCT

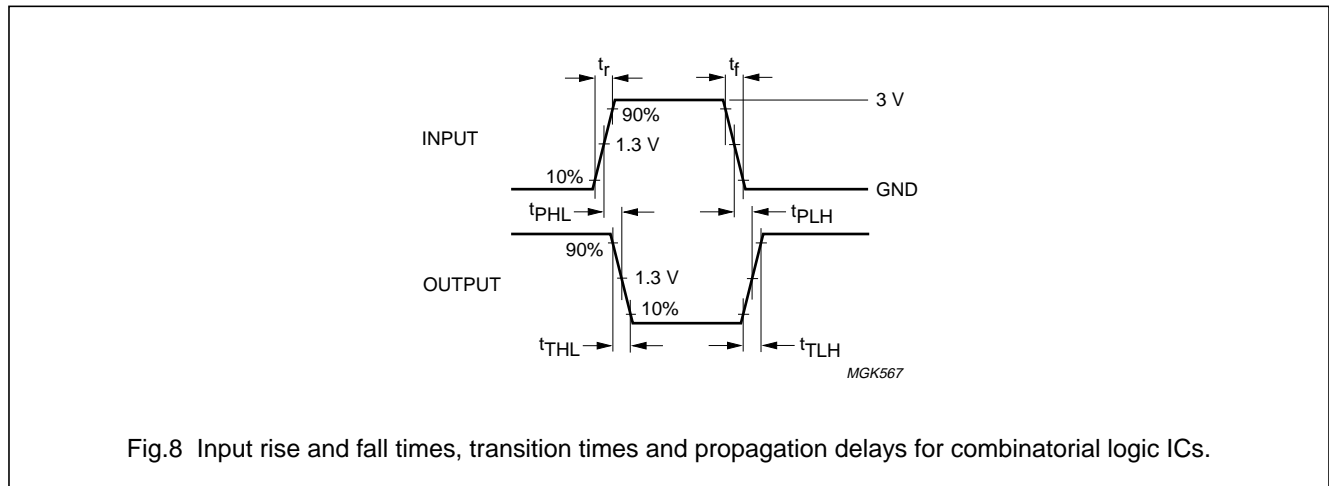

AC waveforms 74HCT

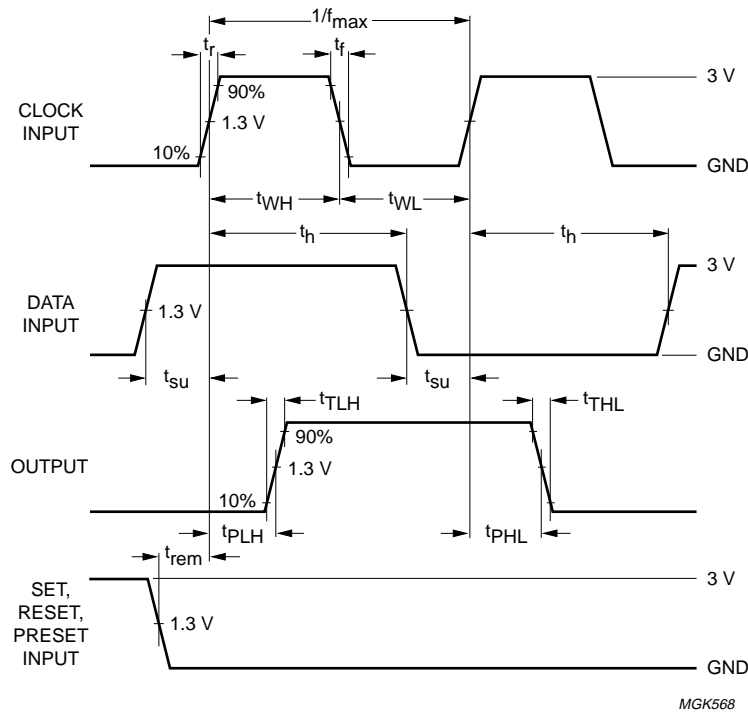

MGK568

- (1) In Fig.9 the active transition of the clock is going from LOW-to-HIGH and the active level of the forcing signals (SET, RESET and PRESET) is HIGH. The actual direction of the transition of the clock input and the actual active levels of the forcing signals are specified in the individual device data sheet.
- (2) For AC measurements: $t_r = t_f = 6$ ns; when measuring f_{max} , there is no constraint on t_r, t_f with 50% duty factor.

Fig.9 Set-up times, hold times, removal times, propagation delays and the maximum clock pulse frequency for sequential logic ICs.

Test circuit for 74HCT

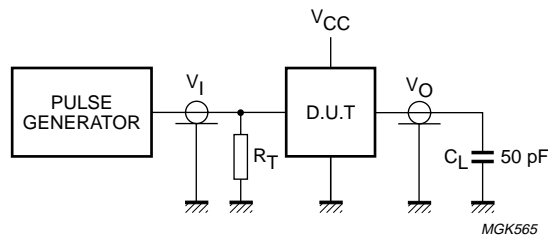

MGK565

- C_L = load capacitance including jig and probe capacitance (see AC CHARACTERISTICS for values).
- R_T = termination resistance should be equal to the output impedance Z_o of the pulse generator.

Fig.10 Test circuit.

AC waveforms 74HCT (continued)

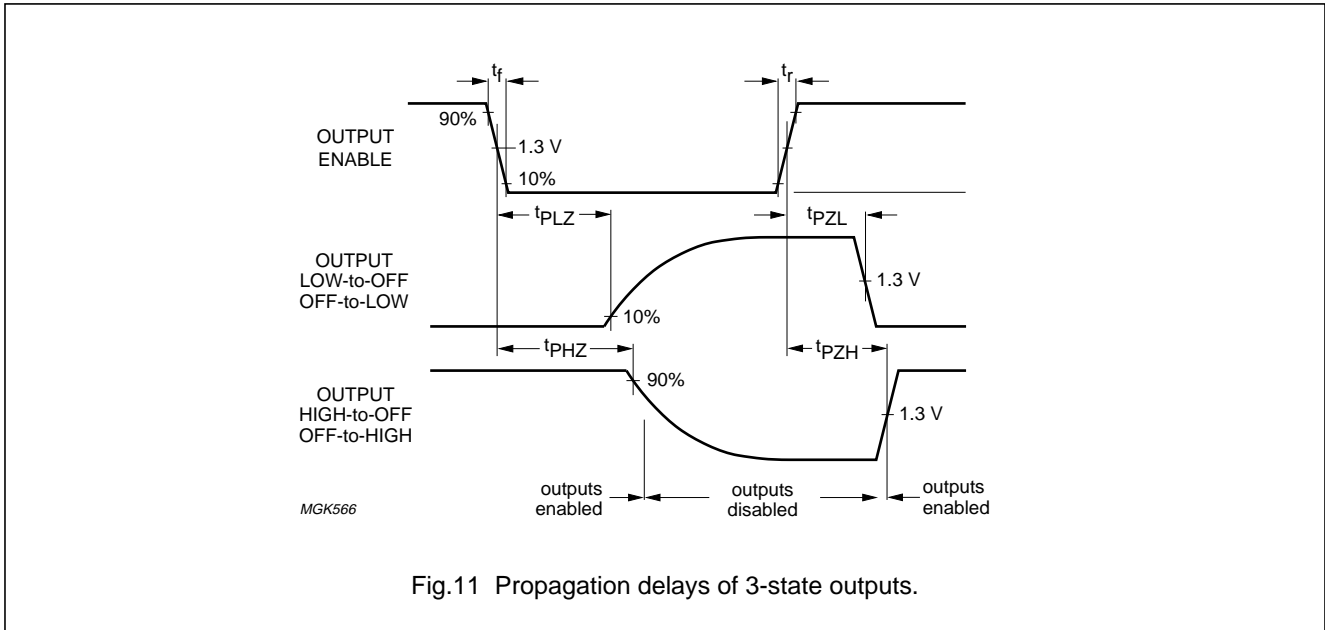

Fig.11 Propagation delays of 3-state outputs.

Test circuit for 74HCT

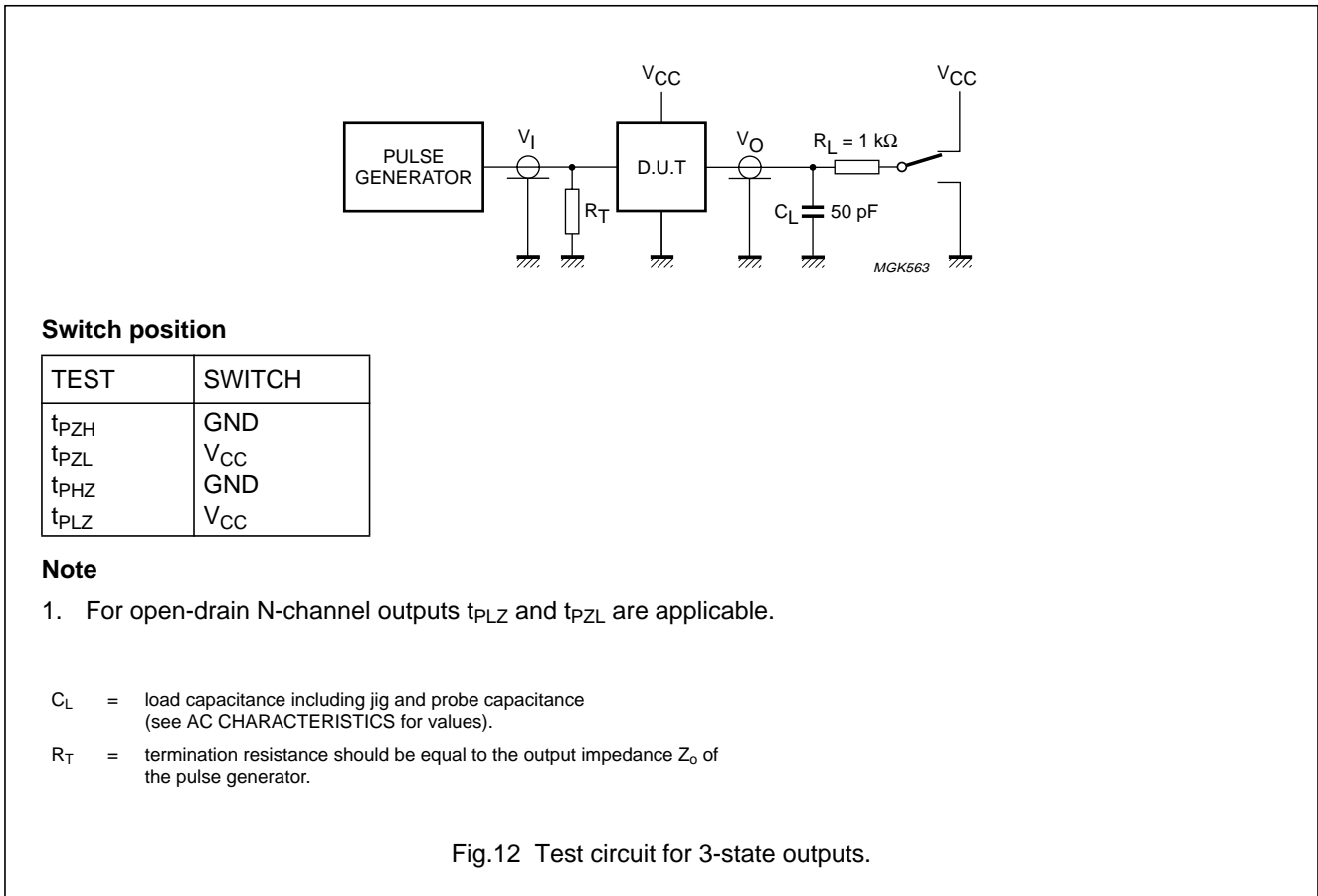

Fig.12 Test circuit for 3-state outputs.

HCMOS family characteristics

FAMILY SPECIFICATIONS

DATA SHEET SPECIFICATION GUIDE

INTRODUCTION

The 74HCMOS data sheets have been designed for ease-of-use. A minimum of cross-referencing for more information is needed.

TYPICAL PROPAGATION DELAY AND FREQUENCY

The typical propagation delays listed at the top of the data sheets are the average of t_{PLH} and t_{PHL} for the longest data path through the device with a 15 pF load.

For clocked devices, the maximum frequency of operation is also given. The typical operating frequency is the maximum device operating frequency with a 50% duty factor and no constraints on t_r and t_f .

LOGIC SYMBOLS

Two logic symbols are given for each device - the conventional one (Logic Symbol) which explicitly shows the internal logic (except for complex logic) and the IEC Logic Symbol as developed by the IEC (International Electrotechnical Commission).

The IEC has been developing a very powerful symbolic language that can show the relationship of each input of a digital logic current to each output without explicitly showing the internal logic.

Internationally, Working Group 2 of IEC Technical Committee TC-3 has prepared a new document (Publication 617-12) which supersedes Publication 117-15, published in 1972.

RATINGS

The "RATINGS" table (Limiting values in accordance with the Absolute Maximum System - IEC134) lists the maximum limits to which the device can be subjected without damage. This doesn't imply that the device will function at these extreme conditions, only that, when these conditions are removed and the device operated within the Recommended Operating Conditions, it will still be functional and its useful life won't have been shortened.

The maximum rated supply voltage of 7 V is well below the typical breakdown voltage of 18 V.

RECOMMENDED OPERATING CONDITIONS

The "RECOMMENDED OPERATING CONDITIONS" table lists the operating ambient temperature and the

conditions under which the limits in the "DC CHARACTERISTICS" and "AC CHARACTERISTICS" tables will be met. The table should not be seen as a set of limits guaranteed by the manufacturer, but as the conditions used to test the devices and guarantee that they will then meet the limits in the DC and AC CHARACTERISTICS tables.

DC CHARACTERISTICS

The "DC CHARACTERISTICS" table reflects the DC limits used during testing. The values published are guaranteed.

The threshold values of V_{IH} and V_{IL} can be tested by the user. If V_{IH} and V_{IL} are applied to the inputs, the output voltages will be those published in the "DC CHARACTERISTICS" table. There is a tendency, by some, to use the published V_{IH} and V_{IL} thresholds to test a device for functionality in a "function-table exercizer" mode. This frequently causes problems because of the noise present at the test head of automated test equipment with cables up to 1 metre. Parametric tests, such as those used for the output levels under the V_{IH} and V_{IL} conditions are done fairly slowly, in the order of milliseconds, so that there is no noise at the inputs when the outputs are measured. But in functionality testing, the outputs are measured much faster, so there can be noise on the inputs, before the device has assumed its final and correct output state. Thus, never use V_{IH} and V_{IL} to test the functionality of any HCMOS device type; instead, use input voltages of V_{CC} (for the HIGH state) and 0 V (for the LOW state). In no way does this imply that the devices are noise-sensitive in the final system.

In the data sheets, it may appear strange that the typical V_{IL} is higher than the maximum V_{IL} . However, this is because V_{ILmax} is the maximum V_{IL} (guaranteed) for all devices that will be recognized as a logic LOW. However, typically a **higher** V_{IL} will also be recognized as a logic LOW. Conversely, the typical V_{IH} is lower than its minimum guaranteed level.

For 74HCMOS, unlike TTL, no output HIGH short-circuit current is specified. The use of this current, for example, to calculate propagation delays with capacitive loads, is covered by the HCMOS graphs showing the output drive capability and those showing the dependence of propagation delay on load capacitance.

The quiescent supply current I_{CC} is the leakage current of all the reversed-biased diodes and the OFF-state MOS transistors. It is measured with the inputs at V_{CC} or GND and is typically a few nA.

HCMOS family characteristics

FAMILY SPECIFICATIONS

AC CHARACTERISTICS

The "AC CHARACTERISTICS" table lists the guaranteed limits when a device is tested under the conditions given in the AC Test Circuits and Waveforms section.

TEST CIRCUITS

Good high-frequency wiring practices should be used in test circuits. Capacitor leads should be as short as possible to minimize ripples on the output waveform transitions and undershoot. Generous ground metal (preferably a ground-plane) should be used for the same reasons. A V_{CC} decoupling capacitor should be provided at the test socket, also with short leads. Input signals should have rise and fall times of 6 ns, a signal swing of 0 V to V_{CC} for 74HC and 0 V to 3 V for 74HCT; a 1.0 MHz square wave is recommended for most propagation delay tests. The repetition rate must be increased for testing f_{max} . Two pulse generators are usually required for testing such parameters as set-up time, hold time and removal time. f_{max} is also tested with 6 ns input rise and fall times, with a 50% duty factor, but for typical f_{max} as high as 60 MHz, there are no constraints on rise and fall times.

HCMOS family characteristics

FAMILY SPECIFICATIONS

DEFINITIONS OF SYMBOLS AND TERMS USED IN HCMOS DATA SHEETS

Currents

Positive current is defined as conventional current flow into a device.

Negative current is defined as conventional current flow out of a device.

I_{CC}	Quiescent power supply current; the current flowing into the V_{CC} supply terminal.
ΔI_{CC}	Additional quiescent supply current per input pin at a specified input voltage and V_{CC} .
I_{GND}	Quiescent power supply current; the current flowing into the GND terminal.
I_I	Input leakage current; the current flowing into a device at a specified input voltage and V_{CC} .
I_{IK}	Input diode current; the current flowing into a device at a specified input voltage.
I_O	Output source or sink current: the current flowing into a device at a specified output voltage.
I_{OK}	Output diode current; the current flowing into a device at a specified output voltage.
I_{OZ}	OFF-state output current; the leakage current flowing into the output of a 3-state device in the OFF-state, when the output is connected to V_{CC} or GND.
I_S	Analog switch leakage current; the current flowing into an analog switch at a specified voltage across the switch and V_{CC} .

Voltages

All voltages are referenced to GND (ground), which is typically 0 V.

GND	Supply voltage; for a device with a single negative power supply, the most negative power supply, used as the reference level for other voltages; typically ground.
V_{CC}	Supply voltage; the most positive potential on the device.
V_{EE}	Supply voltage; one of two (GND and V_{EE}) negative power supplies.
V_H	Hysteresis voltage; difference between the trigger levels, when applying a positive and a negative-going input signal.
V_{IH}	HIGH level input voltage; the range of input voltages that represents a logic HIGH level in the system.

V_{IL}	LOW level input voltage; the range of input voltages that represents a logic LOW level in the system.
V_{OH}	HIGH level output voltage; the range of voltages at an output terminal with a specified output loading and supply voltage. Device inputs are conditioned to establish a HIGH level at the output.
V_{OL}	LOW level output voltage; the range of voltages at an output terminal with a specified output loading and supply voltage. Device inputs are conditioned to establish a LOW level at the output.
V_{T+}	Trigger threshold voltage; positive-going signal.
V_{T-}	Trigger threshold voltage; negative-going signal.

Analog terms

R_{ON}	ON-resistance; the effective ON-state resistance of an analog switch, at a specified voltage across the switch and output load.
ΔR_{ON}	Δ ON-resistance; the difference in ON-resistance between any two switches of an analog device at a specified voltage across the switch and output load.

Capacitances

C_I	Input capacitance; the capacitance measured at a terminal connected to an input of a device.
$C_{I/O}$	Input/Output capacitance; the capacitance measured at a terminal connected to an I/O-pin (e.g. a transceiver).
C_L	Output load capacitance; the capacitance connected to an output terminal including jig and probe capacitance.
C_{PD}	Power dissipation capacitance; the capacitance used to determine the dynamic power dissipation per logic function, when no extra load is provided to the device.
C_S	Switch capacitance; the capacitance of a terminal to a switch of an analog device.

HCMOS family characteristics

FAMILY SPECIFICATIONS

AC switching parameters

f_i	Input frequency; for combinatorial logic devices the maximum number of inputs and outputs switching in accordance with the device function table. For sequential logic devices the clock frequency using alternate HIGH and LOW for data input or using the toggle mode, whichever is applicable.	t_{PLZ}	3-state output disable time; the time between the specified reference points, normally the 50% points for the 74HC devices and the 1.3 V points for the 74HCT devices on the output enable input voltage waveform and a point representing 10% of the output swing on the output voltage waveform of a 3-state device, with the output changing from a LOW level (V_{OL}) to a high impedance OFF-state (Z).
f_o	Output frequency; each output.	t_{PZH}	3-state output enable time; the time between the specified reference points, normally the 50% points for the 74HC devices and 1.3 V points for the 74HCT devices on the output enable input voltage waveform and the 50% point on the output voltage waveform of a 3-state device, with the output changing from a high impedance OFF-state (Z) to a HIGH level (V_{OH}).
f_{max}	Maximum clock frequency; clock input waveforms should have a 50% duty factor and be such as to cause the outputs to be switching from 10% V_{CC} to 90% V_{CC} in accordance with the device function table.	t_{PZL}	3-state output enable time; the time between the specified reference points, normally the 50% points for the 74HC devices and the 1.3 V points for the 74HCT devices on the output enable input voltage waveform and the 50% point on the output voltage waveform of a 3-state device, with the output changing from a high impedance OFF-state (Z) to a LOW level (V_{OL}).
t_h	Hold time; the interval immediately following the active transition of the timing pulse (usually the clock pulse) or following the transition of the control input to its latching level, during which interval the data to be recognized must be maintained at the input to ensure their continued recognition. A negative hold time indicates that the correct logic level may be released prior to the timing pulse and still be recognized.	t_{rem}	Removal time; the time between the end of an overriding asynchronous input, typically a clear or reset input, and the earliest permissible beginning of a synchronous control input, typically a clock input, normally measured at the 50% points for 74HC devices and the 1.3 V points for the 74HCT devices on both input voltage waveforms.
t_r , t_f	Clock input rise and fall times; 10% and 90% values.	t_{su}	Set-up time; the interval immediately preceding the active transition of the timing pulse (usually the clock pulse) or preceding the transition of the control input to its latching level, during which interval the data to be recognized must be maintained at the input to ensure their recognition. A negative set-up time indicates that the correct logic level may be initiated sometime after the active transition of the timing pulse and still be recognized.
t_{PHL}	Propagation delay; the time between the specified reference points, normally the 50% points for 74HC and 74HCU devices on the input and output waveforms and the 1.3 V points for the 74HCT devices, with the output changing from the defined HIGH level to the defined LOW level.		
t_{PLH}	Propagation delay; the time between the specified reference points, normally the 50% points for 74HC and 74HCU devices on the input and output waveforms and the 1.3 V point for the 74HCT devices, with the output changing from the defined LOW level to the defined HIGH level.		
t_{PHZ}	3-state output disable time; the time between the specified reference points, normally the 50% points for the 74HC and 74HCU devices and the 1.3 V points for the 74HCT devices on the output enable input voltage waveform and a point representing 10% of the output swing on the output voltage waveform of a 3-state device, with the output changing from a HIGH level (V_{OH}) to a high impedance OFF-state (Z).		

HCMOS family characteristics

FAMILY SPECIFICATIONS

- t_{THL} Output transition time; the time between two specified reference points on a waveform, normally 90% and 10% points, that is changing from HIGH-to-LOW.
- t_{TLH} Output transition time; the time between two specified reference points on a waveform, normally 10% and 90% points, that is changing from LOW-to-HIGH.
- t_W Pulse width; the time between the 50% amplitude points on the leading and trailing edges of a pulse for 74HC and 74HCU devices and at the 1.3 V points for 74HCT devices.



LittleDiode supplies new, hard to find or obsolete electronic components and semiconductors all over the world.

With over two million different components listed you are sure to find the part you need.

Feel free to visit us today at our online store:

LittleDiode.com

Looking forward to providing you with the best possible service.