

DATA SHEET

74F821/822/823/824/825/826 Bus interface registers

Product specification

1996 Jan 05

IC15 Data Handbook

Bus interface registers

74F821/822/823/824/825/826

- 74F821 10-bit bus interface register, non-inverting (3-State)
 74F822 10-bit bus interface register, inverting (3-State)
 74F823 9-bit bus interface register, non-inverting (3-State)
 74F824 9-bit bus interface register, inverting (3-State)
 74F825 8-bit bus interface register, non-inverting (3-State)
 74F826 8-bit bus interface register, inverting (3-State)

FEATURES

- High speed parallel registers with positive edge-triggered D-type flip-flops
- High performance bus interface buffering for wide data/address paths or busses carrying parity
- High impedance PNP base inputs for reduced loading (20 μ A in high and low states)
- I_{IL} is 20 μ A vs 1000 μ A for AM29821 series
- Buffered control inputs to reduce AC effects
- Ideal where high speed, light loading, or increased fan-in as required with MOS microprocessor
- Positive and negative over-shoots are clamped to ground
- 3-State outputs glitch free during power-up and power-down
- Slim Dip 300 mil package
- Broadside pinout compatible with AMD AM 29821-29826 series
- Outputs sink 64mA and source 24mA
- Industrial temperature range available (-40°C to +85°C) for 74F823

DESCRIPTION

The 74F821 series bus interface registers are designed to eliminate the extra packages required to buffer existing registers and provide extra data width for wider data/address paths of busses carrying parity.

The 74F821/74F822 are buffered 10-bit wide versions of the popular 74F374/74F534 functions.

The 74F822 is the inverted output version of 74F821.

The 74F823 and 74F824 are 9-bit wide buffered registers with clock enable (\overline{CE}) and master reset (\overline{MR}) which are ideal for parity bus interfacing in high microprogrammed systems.

The 74F824 is the inverted version of 74F823.

The 74F825 and 74F826 are 8-bit buffered registers with all the 74F823/74F824 controls plus output enable ($\overline{OE0}$, $\overline{OE1}$, $\overline{OE2}$) to allow multiuser control of the interface, e.g., \overline{CS} , DMA, and RD/ \overline{WR} . They are ideal for uses as an output port requiring high I_{OL}/I_{OH} .

The 74F826 is the inverted version of 74F825.

TYPE	TYPICAL f_{max}	TYPICAL SUPPLY CURRENT (TOTAL)
74F821, 74F822	180MHz	75mA
74F823, 74F824	180MHz	70mA
74F825, 74F826	180MHz	65mA

ORDERING INFORMATION

DESCRIPTION	ORDER CODE		PKG. DWG. #
	COMMERCIAL RANGE $V_{CC} = 5V \pm 10\%$, $T_{amb} = 0^{\circ}C$ to $+70^{\circ}C$	INDUSTRIAL RANGE $V_{CC} = 5V \pm 10\%$, $T_{amb} = -40^{\circ}C$ to $+85^{\circ}C$	
24-pin plastic slim DIP (300mil)	N74F821N, N74F822N, N74F823N, N74F824N, N74F825N, N74F826N	I74F823N	SOT222-1
24-pin plastic SOL	N74F821D, N74F822D, N74F823D, N74F824D, N74F825D, N74F826D	I74F823D	SOT137-1

Bus interface registers

74F821/822/823/824/825/826

INPUT AND OUTPUT LOADING AND FAN OUT TABLE

PINS		DESCRIPTION	74F (U.L.) HIGH/LOW	LOAD VALUE HIGH/LOW
74F821 74F822	Dn	Data inputs	1.0/1.0	20µA/0.6mA
	CP	Clock input	1.0/1.0	20µA/0.6mA
	\overline{OE}	Output enable input (active low)	1.0/3.0	20µA/1.8mA
	Qn, \overline{Qn}	Data outputs	1200/106.7	24mA/64mA
74F823 74F824	Dn	Data inputs	1.0/1.0	20µA/0.6mA
	CP	Clock input	1.0/1.0	20µA/0.6mA
	\overline{CE}	Clock enable input (active low)	1.0/3.0	20µA/1.8mA
	\overline{MR}	Master reset input (active low)	1.0/3.0	20µA/1.8mA
	\overline{OE}	Output enable input (active low)	1.0/3.0	20µA/1.8mA
	Qn, \overline{Qn}	Data outputs	1200/106.7	24mA/64mA
74F825 74F826	Dn	Data inputs	1.0/1.0	20µA/0.6mA
	CP	Clock input	1.0/1.0	20µA/0.6mA
	\overline{CE}	Clock enable input (active low)	1.0/3.0	20µA/1.8mA
	\overline{MR}	Master reset input (active low)	1.0/3.0	20µA/1.8mA
	\overline{OE}	Output enable input (active low)	1.0/3.0	20µA/1.8mA
	Qn, \overline{Qn}	Data outputs	1200/106.7	24mA/64mA

NOTE: One (1.0) FAST unit load is defined as: 20µA in the high state and 0.6mA in the low state.

PIN CONFIGURATION – 74F821

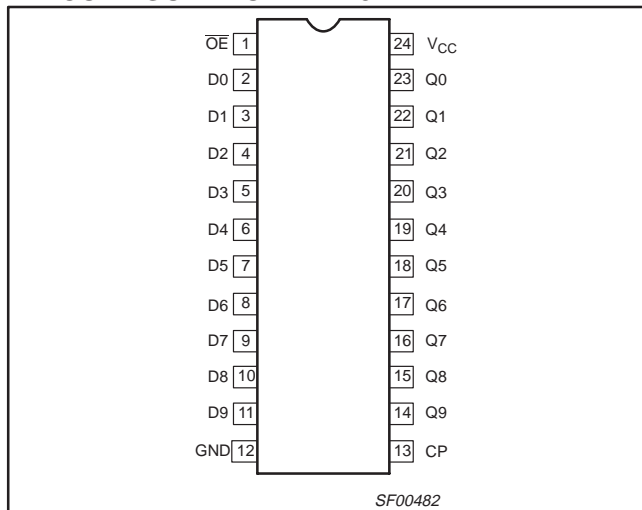

LOGIC SYMBOL – 74F821

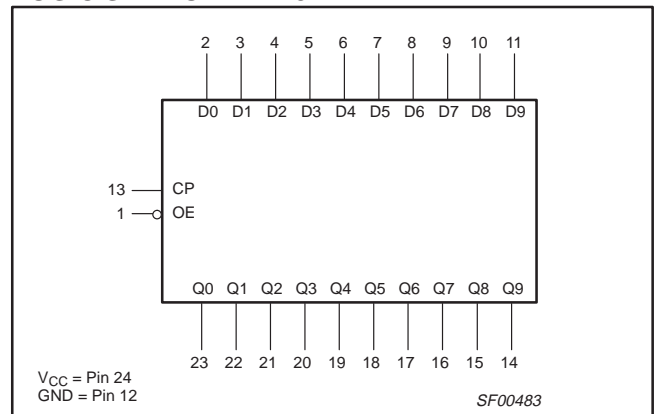

Bus interface registers

74F821/822/823/824/825/826

IEC/IEEE SYMBOL – 74F821

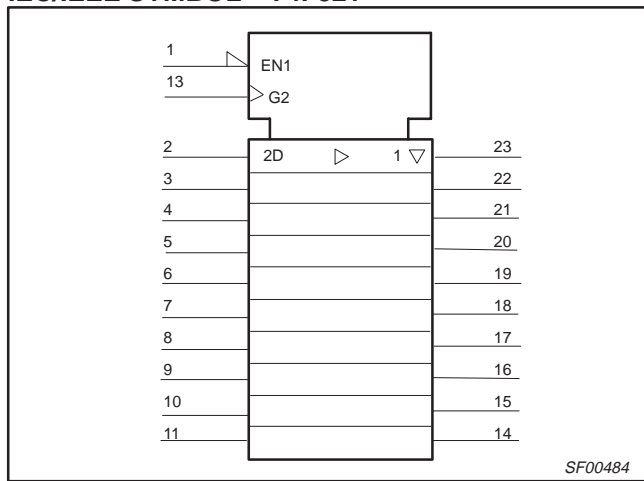

IEC/IEEE SYMBOL – 74F822

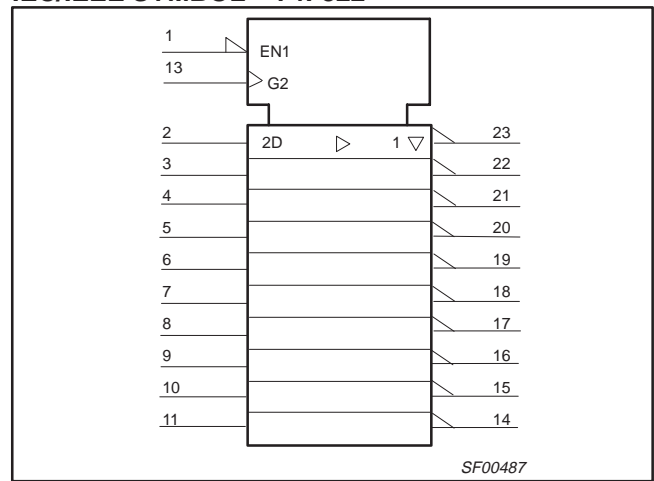

PIN CONFIGURATION – 74F822

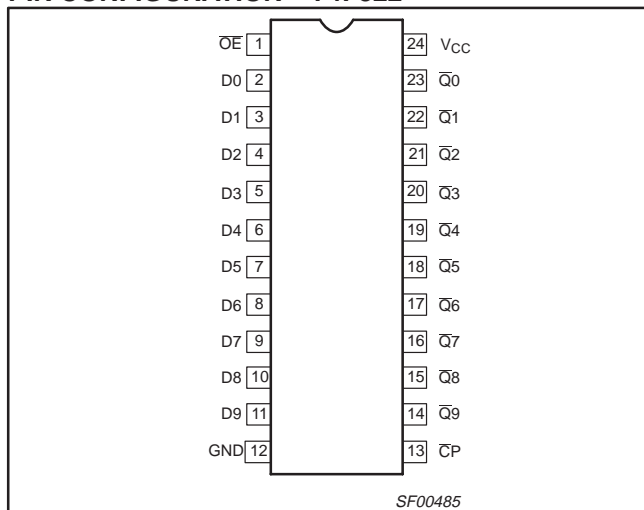

PIN CONFIGURATION – 74F823

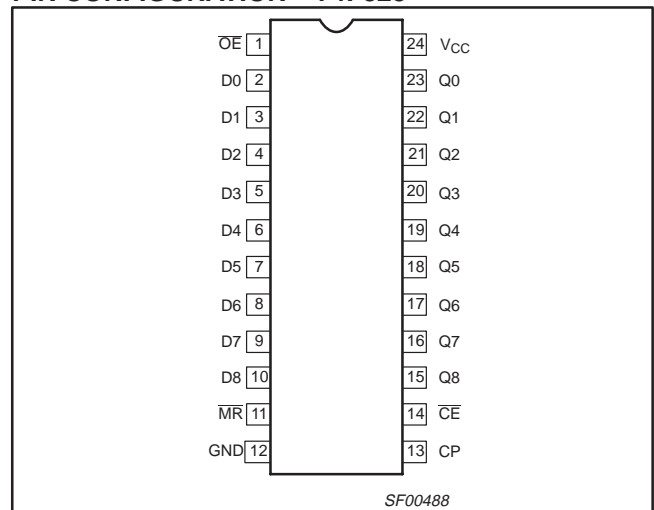

LOGIC SYMBOL – 74F822

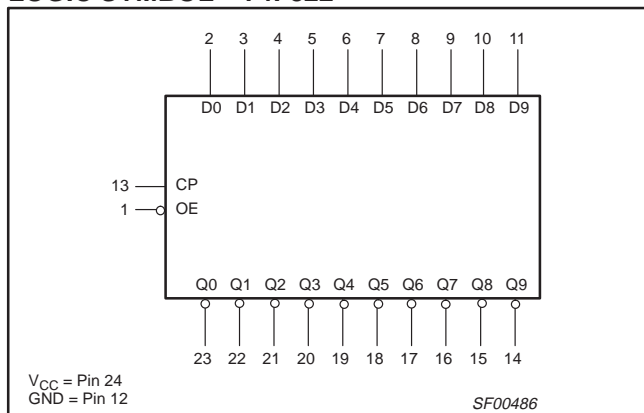

LOGIC SYMBOL – 74F823

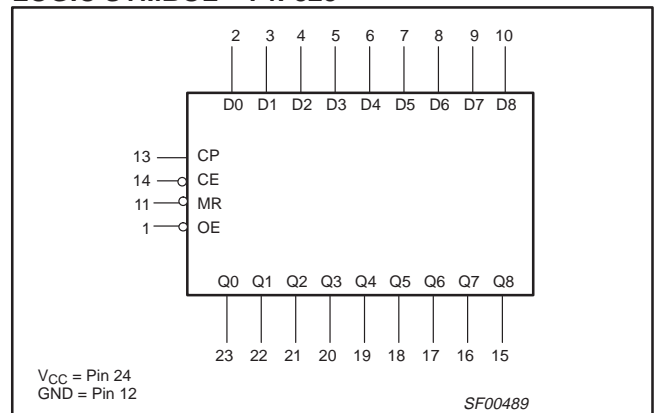

Bus interface registers

74F821/822/823/824/825/826

IEC/IEEE SYMBOL – 74F823

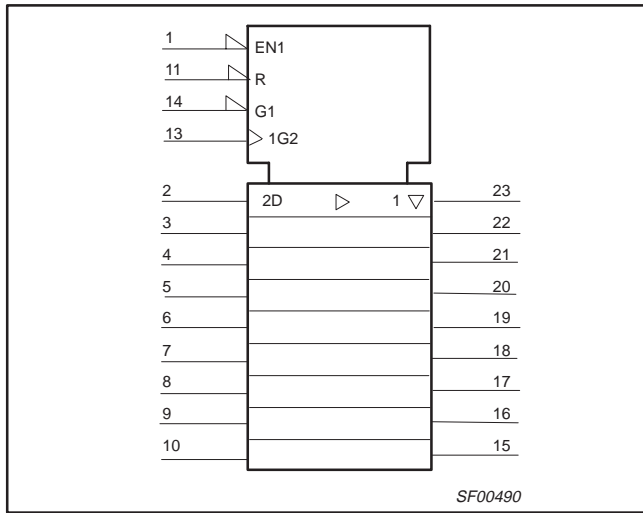

IEC/IEEE SYMBOL – 74F824

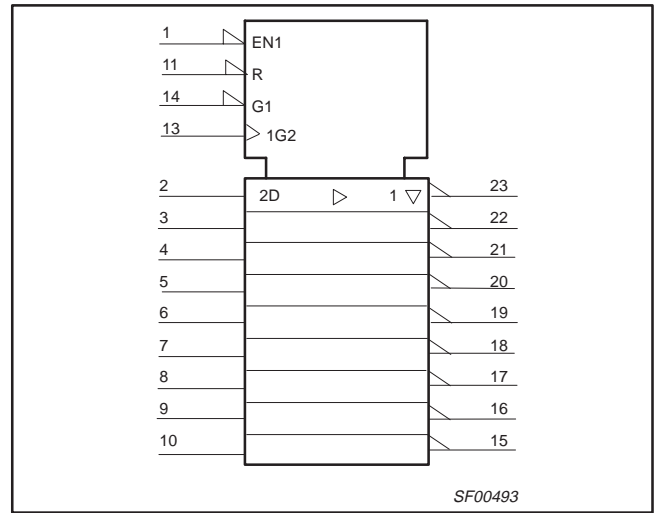

PIN CONFIGURATION – 74F824

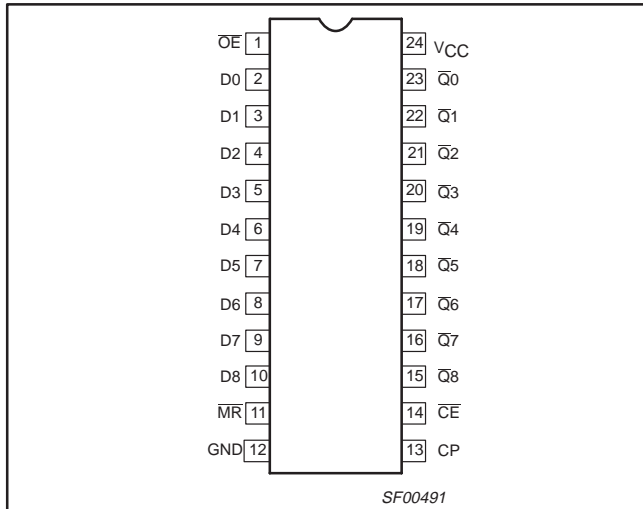

PIN CONFIGURATION – 74F825

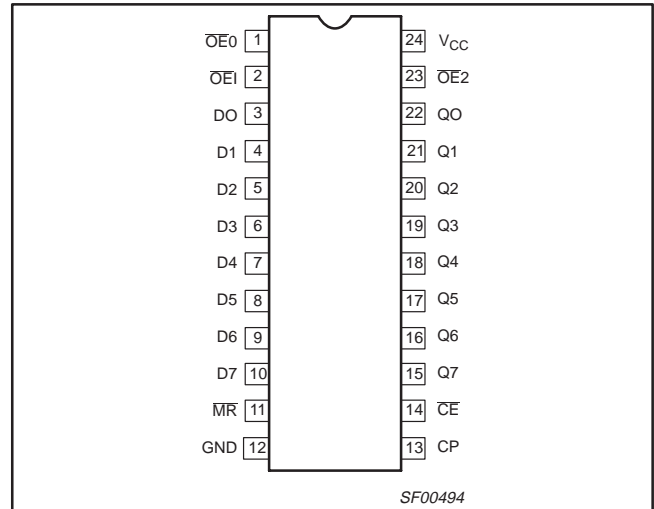

LOGIC SYMBOL – 74F824

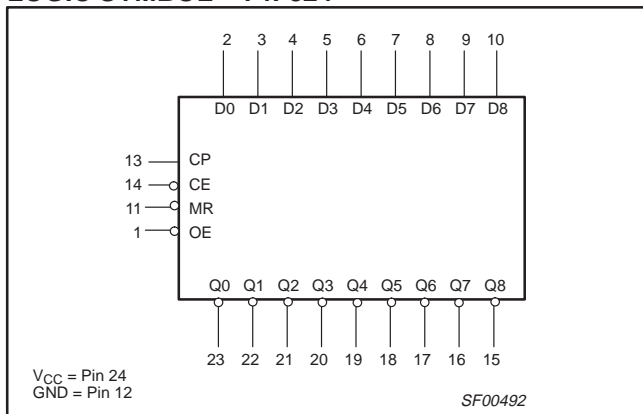

LOGIC SYMBOL – 74F825

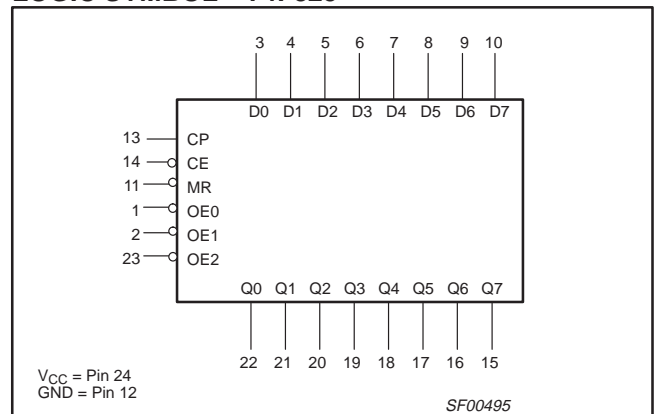

Bus interface registers

74F821/822/823/824/825/826

IEC/IEEE SYMBOL – 74F825

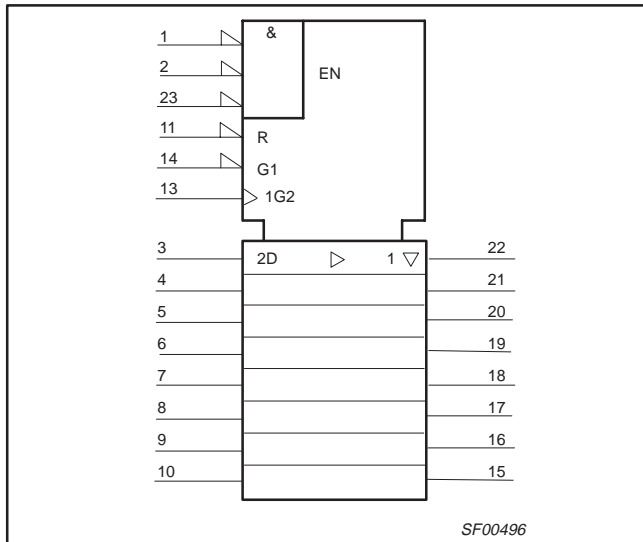

LOGIC SYMBOL – 74F826

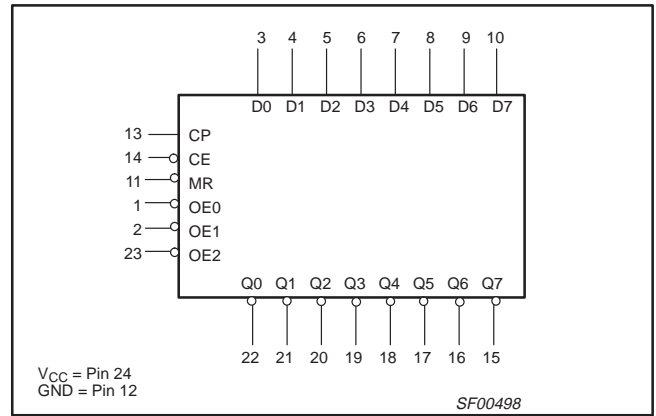

PIN CONFIGURATION – 74F826

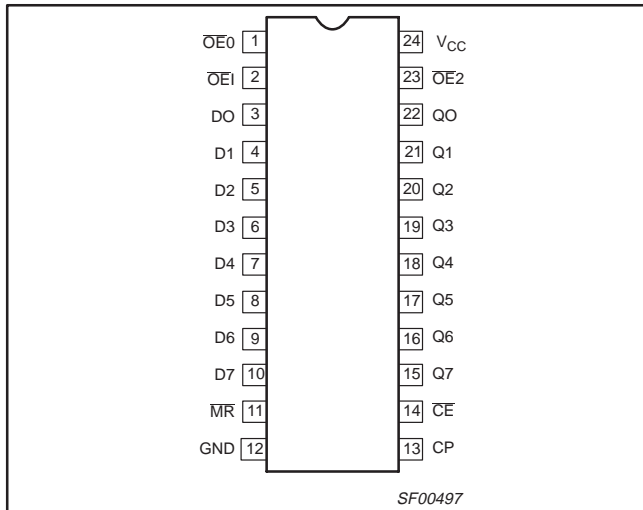

IEC/IEEE SYMBOL – 74F826

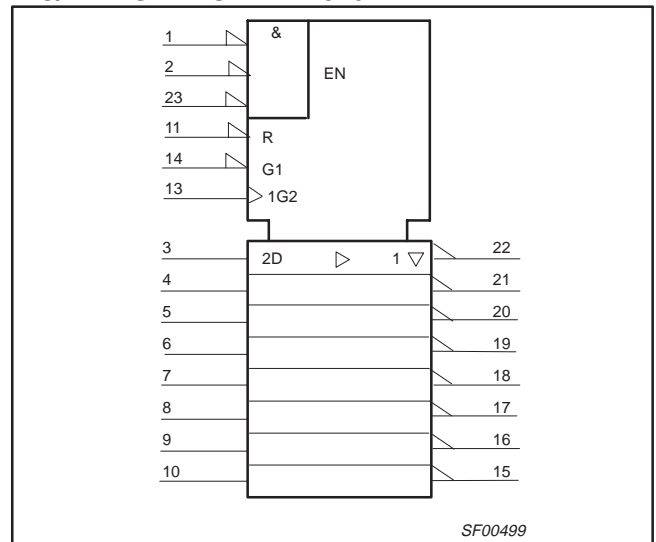

LOGIC DIAGRAM FOR 74F821

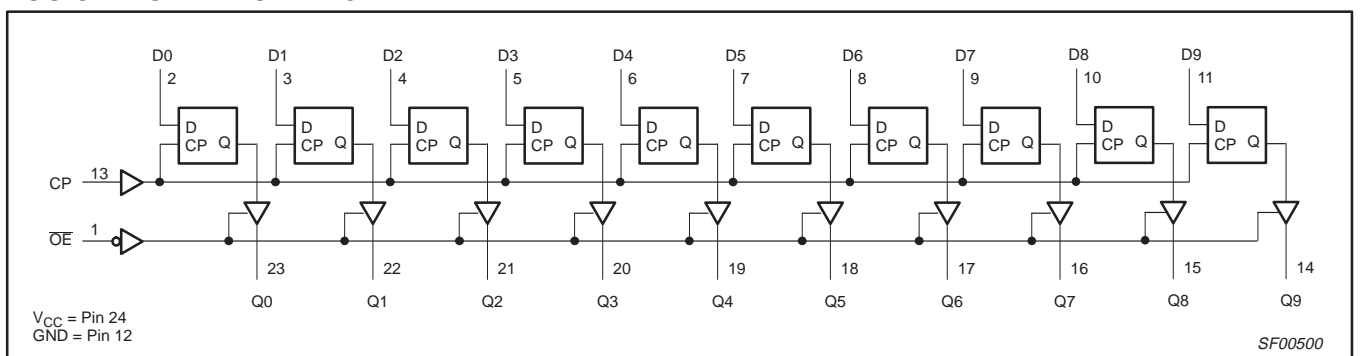

Bus interface registers

74F821/822/823/824/825/826

LOGIC DIAGRAM FOR 74F822

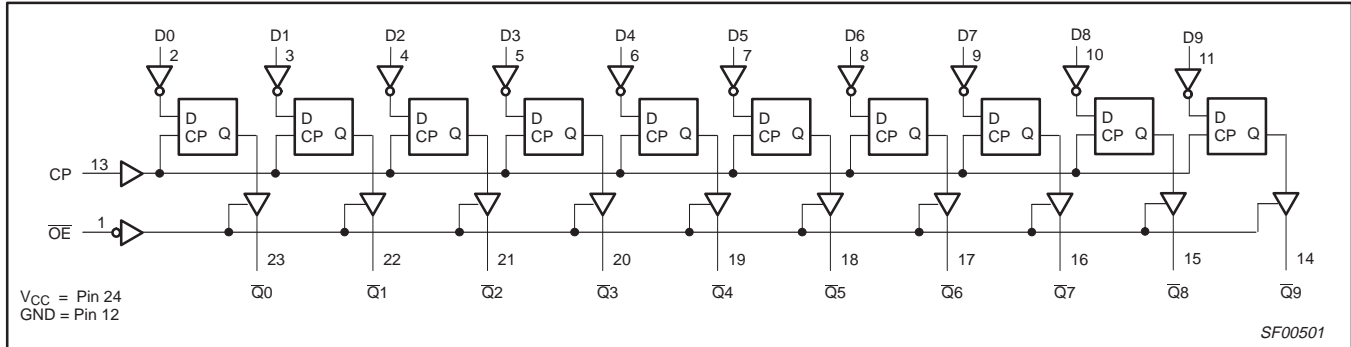

FUNCTION TABLE FOR 74F821 AND 74F822

INPUTS			OUTPUTS		OPERATING MODE
			74F821	74F822	
OE	CP	Dn	Q	Q̄	
L	↑	l	L	H	Load and read data
L	↑	h	H	L	
L	↕	X	NC	NC	Hold
H	X	X	Z	Z	High impedance

- H = High-voltage level
- h = High state must be present one setup time before the low-to-high clock transition
- L = Low-voltage level
- l = Low state must be present one setup time before the low-to-high clock transition
- NC= No change
- X = Don't care
- Z = High impedance "off" state
- ↑ = Low-to-high clock transition
- ↕ = Not low-to-high clock transition

LOGIC DIAGRAM FOR 74F823

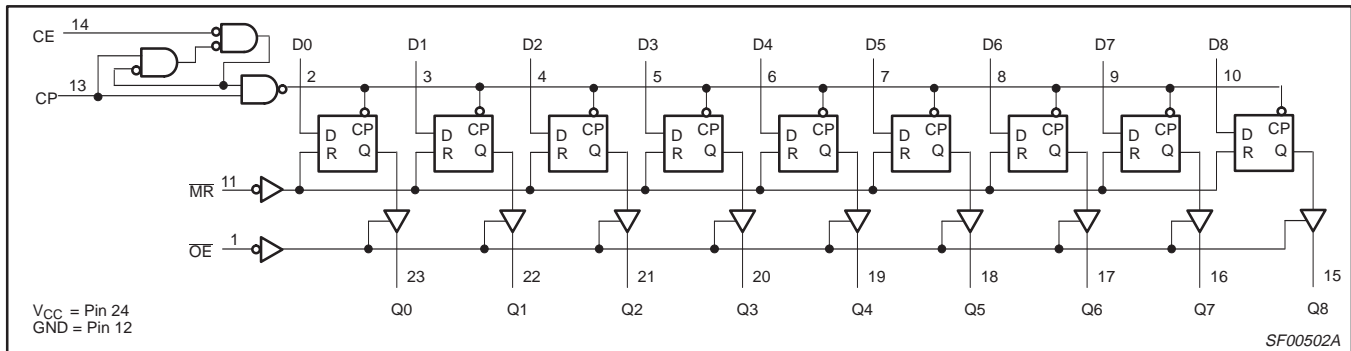

Bus interface registers

74F821/822/823/824/825/826

LOGIC DIAGRAM FOR 74F824

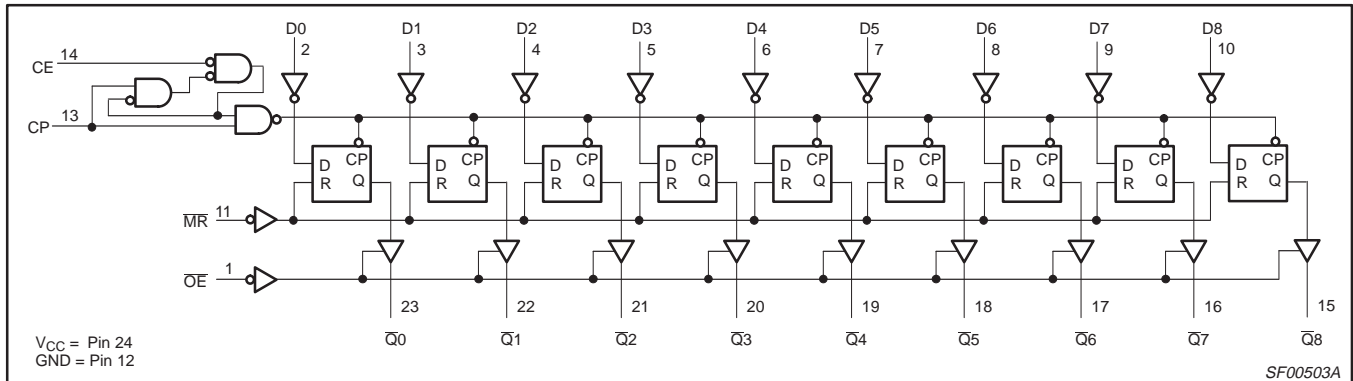

FUNCTION TABLE for 74F823 and 74F824

INPUTS					OUTPUTS		OPERATING MODE
					74F823	74F824	
OE	MR	CE*	CP	Dn	Q	Q̄	
L	L	X	X	X	L	L	Clear
L	H	L	↑	h	H	L	Load and read data
L	H	L	↑	l	L	H	
L	H	H	X	X	NC	NC	Hold
H	X	X	X	X	Z	Z	High impedance

- H = High-voltage level
- h = High state must be present one setup time before the low-to-high clock transition
- L = Low-voltage level
- l = Low state must be present one setup time before the low-to-high clock transition
- NC = No change
- X = Don't care
- Z = High impedance "off" state
- * = Since CE input is sensitive to very short (<3ns) high-to-low-to-high going spikes while CP is high, users should avoid the use of decoders or other potentially glitch prone device on the CE input.
- ↑ = Low-to-high clock transition

LOGIC DIAGRAM FOR 74F825

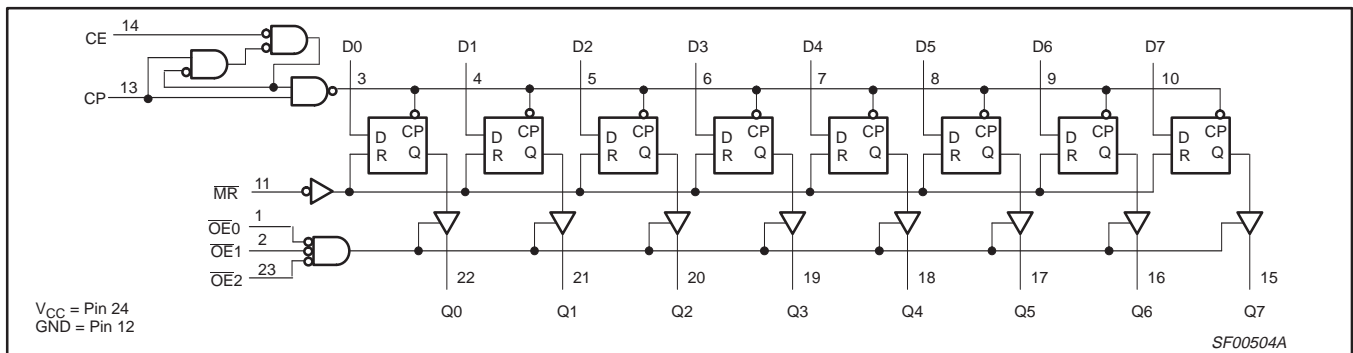

Bus interface registers

74F821/822/823/824/825/826

LOGIC DIAGRAM FOR 74F826

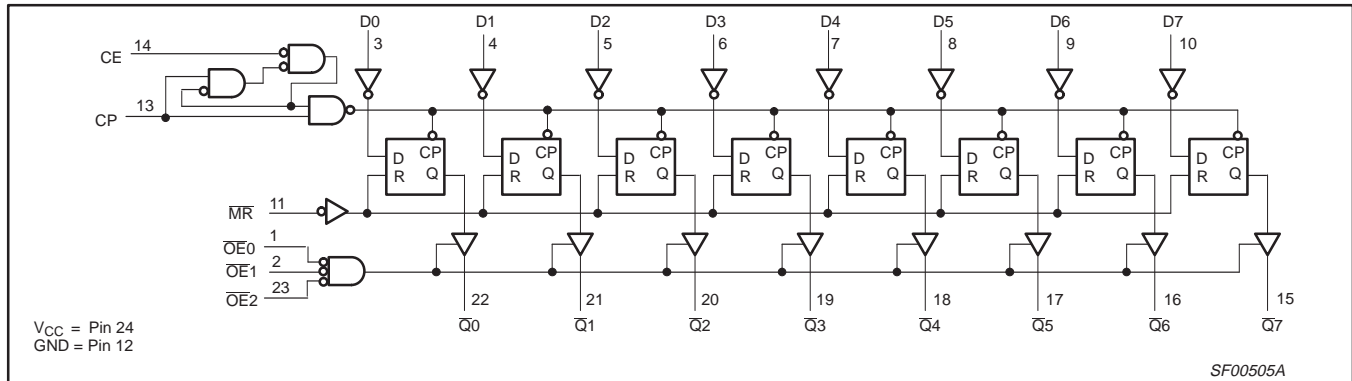

FUNCTION TABLE FOR 74F825 AND 74F826

INPUTS					OUTPUTS		OPERATING MODE
					74F825	74F826	
OE _n	MR	CE*	CP	D _n	Q	Q̄	
L	L	X	X	X	L	L	Clear
L	H	L	↑	h	H	L	Load and read data
L	H	L	↑	l	L	H	
L	H	H	X	X	NC	NC	Hold
H	X	X	X	X	Z	Z	High impedance

- H = High-voltage level
- h = High state must be present one setup time before the low-to-high clock transition
- L = Low-voltage level
- l = Low state must be present one setup time before the low-to-high clock transition
- NC= No change
- X = Don't care
- Z = High impedance "off" state
- * = Since CE input is sensitive to very short (<3ns) high-to-low-to-high going spikes while CP is high, users should avoid the use of decoders or other potentially glitch prone device on the CE input.
- ↑ = Low-to-high clock transition

ABSOLUTE MAXIMUM RATINGS

(Operation beyond the limit set forth in this table may impair the useful life of the device. Unless otherwise noted these limits are over the operating free-air temperature range.)

SYMBOL	PARAMETER	RATING	UNIT
V _{CC}	Supply voltage	-0.5 to +7.0	V
V _{IN}	Input voltage	-0.5 to +7.0	V
I _{IN}	Input current	-30 to +5	mA
V _{OUT}	Voltage applied to output in high output state	-0.5 to V _{CC}	V
I _{OUT}	Current applied to output in low output state	128	mA
T _{amb}	Operating free-air temperature range	Commercial range	0 to +70
		Industrial range	-40 to +85
T _{stg}	Storage temperature range	-65 to +150	°C

Bus interface registers

74F821/822/823/824/825/826

RECOMMENDED OPERATING CONDITIONS

SYMBOL	PARAMETER	LIMITS			UNIT
		MIN	NOM	MAX	
V _{CC}	Supply voltage	4.5	5.0	5.5	V
V _{IH}	High-level input voltage	2.0			V
V _{IL}	Low-level input voltage			0.8	V
I _{Ik}	Input clamp current			-18	mA
I _{OH}	High-level output current			-24	mA
I _{OL}	Low-level output current			64	mA
T _{amb}	Operating free-air temperature range	Commercial range	0	+70	°C
		Industrial range	-40	+85	°C

DC ELECTRICAL CHARACTERISTICS

(Over recommended operating free-air temperature range unless otherwise noted.)

SYMBOL	PARAMETER	TEST CONDITIONS ¹	LIMITS			UNIT	
			MIN	TYP ²	MAX		
V _{OH}	High-level output voltage	V _{CC} = MIN, V _{IL} = MAX, V _{IH} = MIN	I _{OH} = -15mA	±10%V _{CC}	2.4		V
				±5%V _{CC}	2.4		V
			I _{OH} = -24mA	±10%V _{CC}	2.0		V
				±5%V _{CC}	2.0		V
V _{OL}	Low-level output voltage	V _{CC} = MIN, V _{IL} = MAX, V _{IH} = MIN	I _{OL} = MAX	±10%V _{CC}		0.55	V
				±5%V _{CC}		0.42	0.55
V _{IK}	Input clamp voltage	V _{CC} = MIN, I _I = I _{IK}		-0.73	-1.2	V	
I _I	Input current at maximum input voltage	V _{CC} = 0.0V, V _I = 7.0V			100	μA	
I _{IH}	High-level input current	V _{CC} = MAX, V _I = 2.7V			20	μA	
I _{IL}	Low-level input current	V _{CC} = MAX, V _I = 0.5V			-20	μA	
I _{OZH}	Off-state output current, high-level voltage applied	V _{CC} = MAX, V _O = 2.7V			50	μA	
I _{OZL}	Off-state output current, low-level voltage applied	V _{CC} = MAX, V _O = 0.5V			-50	μA	
I _{OS}	Short-circuit output current ³	V _{CC} = MAX	-100		-225	mA	
I _{CC}	Supply current (total)	74F821, 74F822	I _{CCH}	V _{CC} = MAX	75	105	mA
			I _{CCL}		75	105	mA
			I _{CCZ}		75	115	mA
		74F823, 74F824	I _{CCH}	V _{CC} = MAX	65	100	mA
			I _{CCL}		70	105	mA
			I _{CCZ}		75	110	mA
		74F825, 74F826	I _{CCH}	V _{CC} = MAX	60	85	mA
			I _{CCL}		60	90	mA
			I _{CCZ}		65	95	mA

NOTES:

- For conditions shown as MIN or MAX, use the appropriate value specified under recommended operating conditions for the applicable type.
- All typical values are at V_{CC} = 5V, T_{amb} = 25°C.
- Not more than one output should be shorted at a time. For testing I_{OS}, the use of high-speed test apparatus and/or sample-and-hold techniques are preferable in order to minimize internal heating and more accurately reflect operational values. Otherwise, prolonged shorting of a high output may raise the chip temperature well above normal and thereby cause invalid readings in other parameter tests. In any sequence of parameter tests, I_{OS} tests should be performed last.

Bus interface registers

74F821/822/823/824/825/826

AC ELECTRICAL CHARACTERISTICS FOR 74F821/74F822/74F824/74F825/74F826

SYMBOL	PARAMETER		TEST CONDITION	LIMITS					UNIT
				T _{amb} = +25°C V _{CC} = +5.0V C _L = 50pF, R _L = 500Ω			T _{amb} = 0°C to +70°C V _{CC} = +5.0V ± 10% C _L = 50pF, R _L = 500Ω		
				MIN	TYP	MAX	MIN	MAX	
f _{max}	Maximum clock frequency		Waveform 1	150	180		140		ns
t _{PLH} t _{PHL}	Propagation delay CP to Qn or \bar{Q} n	74F821, 74F825, 74F826	Waveform 1	4.0 4.0	6.5 6.0	8.5 8.5	4.0 3.5	9.5 9.0	ns
t _{PLH} t _{PHL}	Propagation delay CP to \bar{Q} n	74F822, 74F824	Waveform 1	4.5 4.5	6.5 6.5	9.0 9.0	4.5 4.5	10.0 9.0	ns
t _{PHL}	Propagation delay $\bar{M}R$ to Qn or \bar{Q} n	74F824 74F825, 74F826	Waveform 2	3.0	5.0	8.0	3.0	8.0	ns
t _{PZH} t _{PZL}	Output enable time $\bar{O}E$ n to Qn or \bar{Q} n		Waveform 4 Waveform 5	2.0 3.0	4.5 5.0	8.0 8.0	2.0 2.5	9.0 9.0	ns
t _{PHZ} t _{PLZ}	Output disable time $\bar{O}E$ n to Qn or \bar{Q} n		Waveform 4 Waveform 5	1.5 1.5	3.5 3.5	6.5 6.5	1.5 1.5	7.5 7.5	ns

AC SETUP REQUIREMENTS FOR 74F821/74F822/74F824/74F825/74F826

SYMBOL	PARAMETER		TEST CONDITION	LIMITS					UNIT
				T _{amb} = +25°C V _{CC} = +5.0V C _L = 50pF, R _L = 500Ω			T _{amb} = 0°C to +70°C V _{CC} = +5.0V ± 10% C _L = 50pF, R _L = 500Ω		
				MIN	TYP	MAX	MIN	MAX	
t _{SU} (H) t _{SU} (L)	Setup time, high or low Dn to CP		Waveform 3	1.0 1.0			1.0 1.0		ns
t _H (H) t _H (L)	Hold time, high or low Dn to CP		Waveform 3	2.0 2.0			2.0 2.0		ns
t _W (H) t _W (L)	CP Pulse width, high or low		Waveform 1	3.5 3.5			4.0 4.0		ns
t _{SU} (H) t _{SU} (L)	Setup time, high or low, $\bar{C}E$ to CP	74F824, 74F825, 74F826	Waveform 3	0.0 2.0			0.0 2.0		ns
t _H (H) t _H (L)	Hold time, high or low $\bar{C}E$ to CP		Waveform 3	0.0 3.0			0.0 3.5		ns
t _W (L)	$\bar{M}R$ Pulse width, low		Waveform 2	4.5			4.5		ns
t _{rec}	Recovery time, $\bar{M}R$ to CP		Waveform 2	2.5			2.5		ns

Bus interface registers

74F821/822/823/824/825/826

AC ELECTRICAL CHARACTERISTICS FOR 74F823

SYMBOL	PARAMETER	TEST CONDITION	LIMITS						UNIT	
			$T_{amb} = +25^{\circ}\text{C}$ $V_{CC} = +5.0\text{V}$ $C_L = 50\text{pF}$ $R_L = 500\Omega$			$T_{amb} = 0^{\circ}\text{C to } +70^{\circ}\text{C}$ $V_{CC} = +5.0\text{V} \pm 10\%$ $C_L = 50\text{pF}$ $R_L = 500\Omega$		$T_{amb} = -40^{\circ}\text{C to } +85^{\circ}\text{C}$ $V_{CC} = +5.0\text{V} \pm 10\%$ $C_L = 50\text{pF}$ $R_L = 500\Omega$		
			MIN	TYP	MAX	MIN	MAX	MIN		MAX
f_{max}	Maximum clock frequency	Waveform 1	150	180		140		130		ns
t_{PLH} t_{PHL}	Propagation delay CP to Q_n or \bar{Q}_n	Waveform 1	4.0 4.0	6.5 6.0	8.5 8.5	4.0 3.5	9.5 9.0	4.0 3.5	10.0 9.0	ns
t_{PHL}	Propagation delay $\bar{M}R$ to Q_n or \bar{Q}_n	Waveform 2	3.0	5.0	8.0	3.0	8.0	3.0	8.5	ns
t_{PZH} t_{PZL}	Output enable time OEn to Q_n or \bar{Q}_n	Waveform 4 Waveform 5	2.0 3.0	4.5 5.0	8.0 8.0	2.0 2.5	9.0 9.0	2.0 2.5	11.0 9.0	ns
t_{PHZ} t_{PLZ}	Output disable time OEn to Q_n or \bar{Q}_n	Waveform 4 Waveform 5	1.5 1.5	3.5 3.5	6.5 6.5	1.5 1.5	7.5 7.5	1.5 1.5	8.5 8.5	ns

AC SETUP REQUIREMENTS FOR 74F823

SYMBOL	PARAMETER	TEST CONDITION	LIMITS						UNIT	
			$T_{amb} = +25^{\circ}\text{C}$ $V_{CC} = +5.0\text{V}$ $C_L = 50\text{pF}$ $R_L = 500\Omega$			$T_{amb} = 0^{\circ}\text{C to } +70^{\circ}\text{C}$ $V_{CC} = +5.0\text{V} \pm 10\%$ $C_L = 50\text{pF}$ $R_L = 500\Omega$		$T_{amb} = -40^{\circ}\text{C to } +85^{\circ}\text{C}$ $V_{CC} = +5.0\text{V} \pm 10\%$ $C_L = 50\text{pF}$ $R_L = 500\Omega$		
			MIN	TYP	MAX	MIN	MAX	MIN		MAX
$t_{su}(H)$ $t_{su}(L)$	Setup time, high or low Dn to CP	Waveform 3	1.0 1.0			1.0 1.0		2.0 1.5		ns
$t_h(H)$ $t_h(L)$	Hold time, high or low Dn to CP	Waveform 3	2.0 2.0			2.0 2.0		2.5 2.0		ns
$t_w(H)$ $t_w(L)$	CP Pulse width, high or low	Waveform 1	3.5 3.5			4.0 4.0		4.0 4.0		ns
$t_{su}(H)$ $t_{su}(L)$	Setup time, high or low, $\bar{C}E$ to CP	Waveform 3	0.0 2.0			0.0 2.0		0.0 2.0		ns
$t_h(H)$ $t_h(L)$	Hold time, high or low $\bar{C}E$ to CP	Waveform 3	0.0 3.0			0.0 3.5		1.5 4.0		ns
$t_w(L)$	$\bar{M}R$ Pulse width, low	Waveform 2	4.5			4.5		4.5		ns
t_{rec}	Recovery time, $\bar{M}R$ to CP	Waveform 2	2.5			2.5		2.5		ns

Bus interface registers

74F821/822/823/824/825/826

AC WAVEFORMS

For all waveforms, $V_M = 1.5V$.

The shaded areas indicate when the input is permitted to change for predictable output performance.

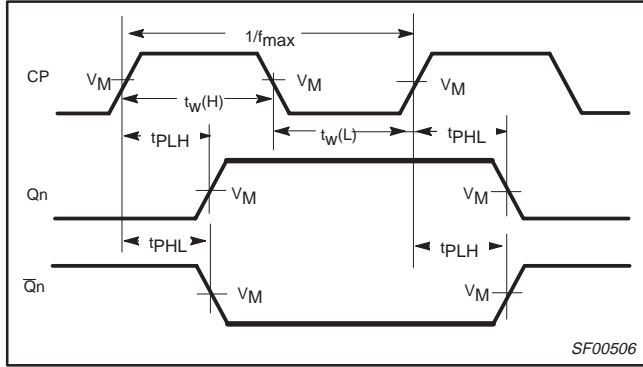

Waveform 1. Propagation delay for clock input to output, clock pulse width, and maximum clock frequency

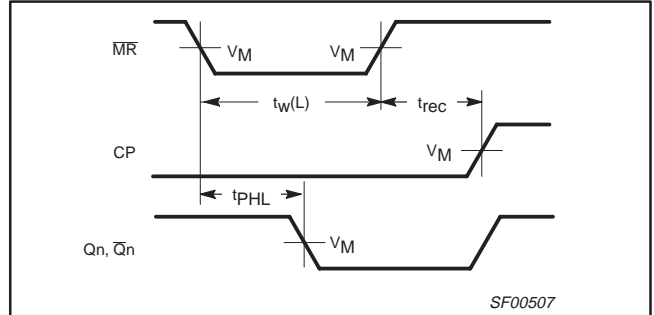

Waveform 2. Master reset pulse width, master reset to output delay and master reset to clock recovery time

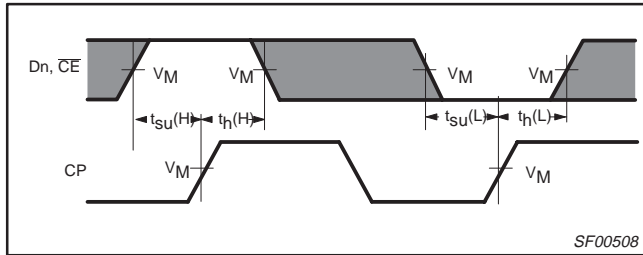

Waveform 3. Data setup time and hold times

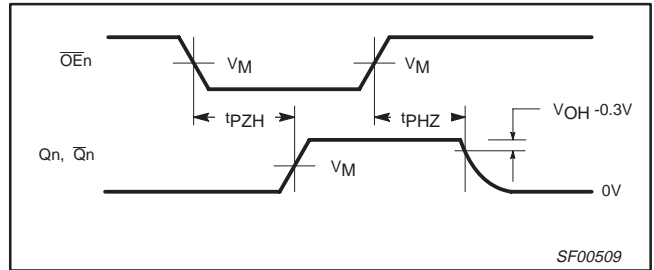

Waveform 4. 3-State output enable time to high level and output disable time from high level

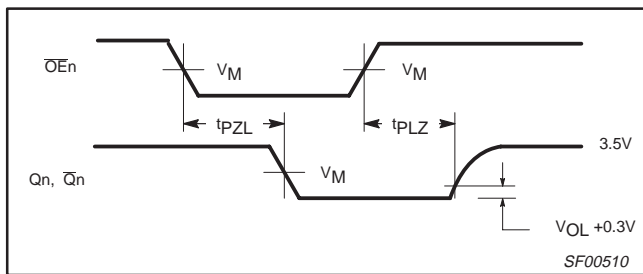

Waveform 5. 3-State output enable time to low level and output disable time from low level

Bus interface registers

74F821/822/823/824/825/826

TEST CIRCUIT AND WAVEFORMS

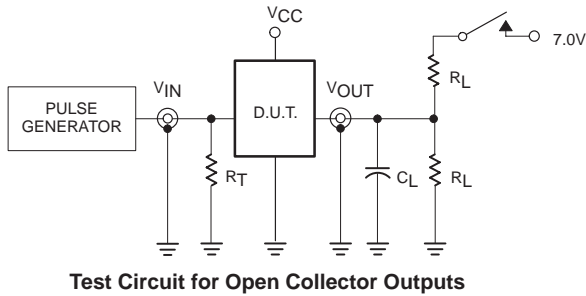

SWITCH POSITION

TEST	SWITCH
t_{PLZ}	closed
t_{PZL}	closed
All other	open

DEFINITIONS:

- R_L = Load resistor; see AC electrical characteristics for value.
- C_L = Load capacitance includes jig and probe capacitance; see AC electrical characteristics for value.
- R_T = Termination resistance should be equal to Z_{OUT} of pulse generators.

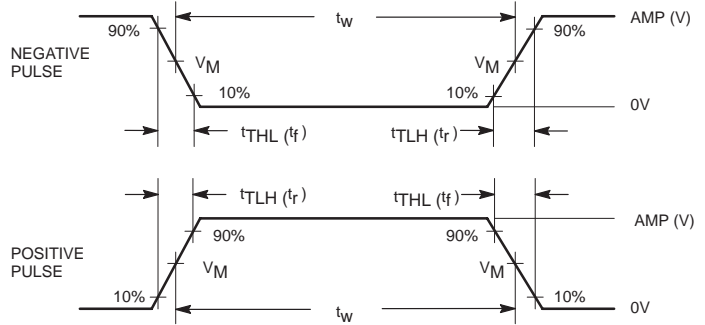

family	INPUT PULSE REQUIREMENTS					
	amplitude	V_M	rep. rate	t_w	t_{TLH}	t_{THL}
74F	3.0V	1.5V	1MHz	500ns	2.5ns	2.5ns

SF00128

Bus interface registers

74F821/822/823/824/825/826

DIP24: plastic dual in-line package; 24 leads (300 mil)

SOT222-1

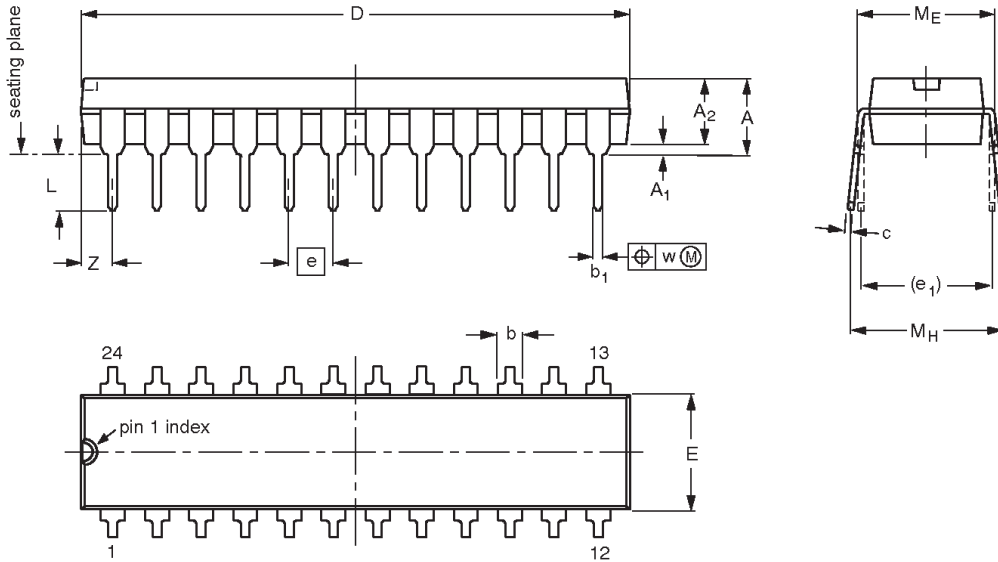

DIMENSIONS (millimetre dimensions are derived from the original inch dimensions)

UNIT	A max.	A ₁ min.	A ₂ max.	b	b ₁	c	D ⁽¹⁾	E ⁽¹⁾	e	e ₁	L	M _E	M _H	w	Z ⁽¹⁾ max.
mm	4.70	0.38	3.94	1.63 1.14	0.56 0.43	0.36 0.25	31.9 31.5	6.73 6.48	2.54	7.62	3.51 3.05	8.13 7.62	10.03 7.62	0.25	2.05
inches	0.185	0.015	0.155	0.064 0.045	0.022 0.017	0.014 0.010	1.256 1.240	0.265 0.255	0.100	0.300	0.138 0.120	0.32 0.30	0.395 0.300	0.01	0.081

Note

1. Plastic or metal protrusions of 0.01 inches maximum per side are not included.

OUTLINE VERSION	REFERENCES				EUROPEAN PROJECTION	ISSUE DATE
	IEC	JEDEC	EIAJ			
SOT222-1		MS-001AF				95-03-11

Bus interface registers

74F821/822/823/824/825/826

SO24: plastic small outline package; 24 leads; body width 7.5 mm

SOT137-1

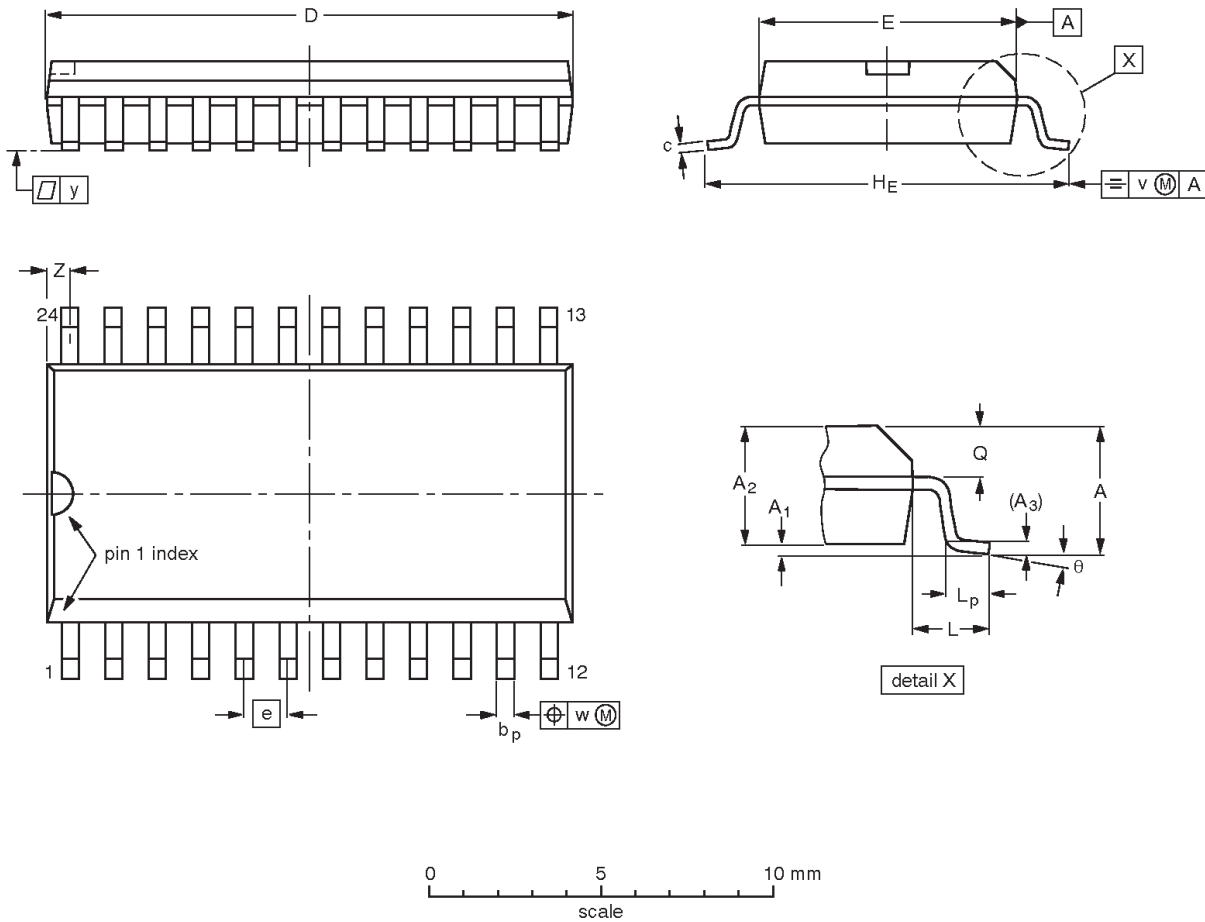

DIMENSIONS (inch dimensions are derived from the original mm dimensions)

UNIT	A max.	A ₁	A ₂	A ₃	b _p	c	D ⁽¹⁾	E ⁽¹⁾	e	H _E	L	L _p	Q	v	w	y	z ⁽¹⁾	θ
mm	2.65	0.30 0.10	2.45 2.25	0.25	0.49 0.36	0.32 0.23	15.6 15.2	7.6 7.4	1.27	10.65 10.00	1.4	1.1 0.4	1.1 1.0	0.25	0.25	0.1	0.9 0.4	8° 0°
inches	0.10	0.012 0.004	0.096 0.089	0.01	0.019 0.014	0.013 0.009	0.61 0.60	0.30 0.29	0.050	0.419 0.394	0.055	0.043 0.016	0.043 0.039	0.01	0.01	0.004	0.035 0.016	

Note

1. Plastic or metal protrusions of 0.15 mm maximum per side are not included.

OUTLINE VERSION	REFERENCES				EUROPEAN PROJECTION	ISSUE DATE
	IEC	JEDEC	EIAJ			
SOT137-1	075E05	MS-013AD				95-01-24 97-05-22

Bus interface registers

74F821/822/823/824/825/826

NOTES

Bus interface registers

74F821/822/823/824/825/826

DEFINITIONS

Data Sheet Identification	Product Status	Definition
<i>Objective Specification</i>	Formative or in Design	This data sheet contains the design target or goal specifications for product development. Specifications may change in any manner without notice.
<i>Preliminary Specification</i>	Preproduction Product	This data sheet contains preliminary data, and supplementary data will be published at a later date. Philips Semiconductors reserves the right to make changes at any time without notice in order to improve design and supply the best possible product.
<i>Product Specification</i>	Full Production	This data sheet contains Final Specifications. Philips Semiconductors reserves the right to make changes at any time without notice, in order to improve design and supply the best possible product.

Philips Semiconductors and Philips Electronics North America Corporation reserve the right to make changes, without notice, in the products, including circuits, standard cells, and/or software, described or contained herein in order to improve design and/or performance. Philips Semiconductors assumes no responsibility or liability for the use of any of these products, conveys no license or title under any patent, copyright, or mask work right to these products, and makes no representations or warranties that these products are free from patent, copyright, or mask work right infringement, unless otherwise specified. Applications that are described herein for any of these products are for illustrative purposes only. Philips Semiconductors makes no representation or warranty that such applications will be suitable for the specified use without further testing or modification.

LIFE SUPPORT APPLICATIONS

Philips Semiconductors and Philips Electronics North America Corporation Products are not designed for use in life support appliances, devices, or systems where malfunction of a Philips Semiconductors and Philips Electronics North America Corporation Product can reasonably be expected to result in a personal injury. Philips Semiconductors and Philips Electronics North America Corporation customers using or selling Philips Semiconductors and Philips Electronics North America Corporation Products for use in such applications do so at their own risk and agree to fully indemnify Philips Semiconductors and Philips Electronics North America Corporation for any damages resulting from such improper use or sale.

Philips Semiconductors
811 East Arques Avenue
P.O. Box 3409
Sunnyvale, California 94088-3409
Telephone 800-234-7381

Philips Semiconductors and Philips Electronics North America Corporation register eligible circuits under the Semiconductor Chip Protection Act.
 © Copyright Philips Electronics North America Corporation 1996
 All rights reserved. Printed in U.S.A.

(print code)

Date of release: July 1994

Document order number:

9397-750-05185



LittleDiode supplies new, hard to find or obsolete electronic components and semiconductors all over the world.

With over two million different components listed you are sure to find the part you need.

Feel free to visit us today at our online store:

LittleDiode.com

Looking forward to providing you with the best possible service.