

Octal shift/count registered transceiver with adder and parity (3–State)

FAST 74F807

FEATURES

- High speed parallel registers with positive edge–triggered D–type flip–flops
- High speed full adder
- 8–bit parity generator
- High impedance PNP inputs for light bus loading
- Center V_{CC} and GND pins and controlled output buffers minimize ground–bounce problems
- 3–State glitch–free power–up and power–down
- Broadside pinout

DESCRIPTION

The 74F807 is a registered transceiver that also has the capability to perform count, shift, and add functions. It is also has the capability to generate a parity bit output. All of this is done within a 28–pin package.

The \overline{MR} input is an overriding asynchronous reset which forces the STATOUT output low as well as the A and B busses.

The A and B busses have separate \overline{OE} inputs (\overline{OEA} , \overline{OEB}). These inputs have no bearing on the internal functioning of

this device only on the output states. Both \overline{OE} pins are enabled low.

All operating modes, other than clear, 3–State, and the two hold modes require the rising edge of the clock. All setup and hold times must be observed for proper functioning.

Data on the internal register can be switched on either the A or B ports for output.

Depeding on the state of the select inputs (S0, S1, S2), and carry in/ serial in/ clock enable (CI/SI/CE), the 74F807 has nine distinct operating modes:

1. Add mode w/carry in – the CI/SI/CE input is used as a carry in signal and the STATOUT output is the carry out signal. (In add mode the COUT is NOT registered. This means the carry output signal appears at the STATOUT output one clock prior to the related data.) In this mode, the CI/SI/CE input is added to the register contents and to the inputs. (The adder uses only the A_n inputs, not the B_n inputs.)
2. Add mode wo/carry in — same as above except the CI/SI/CE input is not included in the addition.
3. Count w/count enable (count) — the CI/SI/CE input is now used as the count enable

input and the STATOUT output is terminal count. In this mode the CI/SI/CE input must be high to enable the count function. The register contents are incremented by one.

4. Count w/count enable (hold) — same as above except no incrementing occurs.

5. Count wo/count enable — same as number 3 except the CI/SI/CE input has no control over counting or holding.

6. Shift — The CI/SI/CE input now becomes the serial input and the STATOUT output becomes the serial output. In this mode the CI/SI/CE input is shifted into the Q0 register, Q0 into the Q1 register etc. The Q7 register is shifted into the STATOUT.

7. Load A inputs — The CI/SI/CE input has no bearing in either of the load modes. The STATOUT output becomes the parity out. The parity out is high for an odd number of registered bits high, and low for even number of registered bits high (even parity). In this mode the A_n inputs are loaded into the internal register and output to the B bus. If $\overline{OEA} = \text{low}$ the internal register would wrap around and be loaded again.

8. Load B inputs — same as number 7 except the A and B busses are switched.

9. Hold — Again the CI/SI/CE input is not used; the STATOUT output is still the parity out. In this mode either the A bus, B bus or both can be held with the registered data. No other operation is performed.

| TYPE | TYPICAL f_{max} | TYPICAL SUPPLY CURRENT (TOTAL) |
|--------|-------------------|--------------------------------|
| 74F807 | 115MHz | 155mA |

ORDERING INFORMATION

| DESCRIPTION | ORDER CODE |
|-------------------------------|---|
| | COMMERCIAL RANGE $V_{CC} = 5V \pm 10\%$, $T_{amb} = 0^\circ C$ to $+70^\circ C$ |
| 28–pin plastic DIP (300 mils) | N74F807N |
| 28–pin SOL ¹ | N74F807D |
| 28–pin PLCC | N74F807A |

Note to ordering information

1. Thermal mounting techniques are recommended. See SMD Process Applications (page 17) for a discussion of thermal consideration for surface mounted devices.

Octal shift/count registered transceiver with adder and parity (3-State)

FAST 74F807

INPUT AND OUTPUT LOADING AND FAN OUT TABLE

| PINS | DESCRIPTION | 74F (U.L.) HIGH/LOW | LOAD VALUE HIGH/LOW |
|-------------------------------------|---------------------------------------|---------------------|---------------------|
| An, Bn | Data I/O inputs | 3.5/0.166 | 70µA/70µA |
| \overline{OEA} , \overline{OEB} | A output enable inputs | 1.0/0.033 | 20µA/20µA |
| CI/SI/CE | Carry in/serial in/clock enable input | 1.0/0.033 | 20µA/20µA |
| CP | Clock input | 1.0/0.033 | 20µA/20µA |
| \overline{MR} | Master reset input (active low) | 1.0/0.033 | 20µA/20µA |
| Sn | Select inputs | 1.0/0.033 | 20µA/20µA |
| STATOUT | Status out output | 150/40 | 3mA/24mA |
| An, Bn | Data I/O outputs | 150/40 | 3mA/24mA |

Note to input and output loading and fan out table

- One (1.0) FAST unit load is defined as: 20µA in the high state and 0.6mA in the low state.

PIN CONFIGURATION

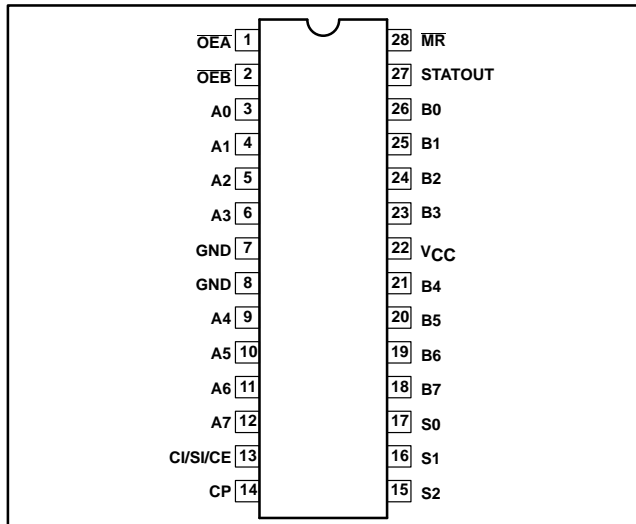

PIN CONFIGURATION PLCC

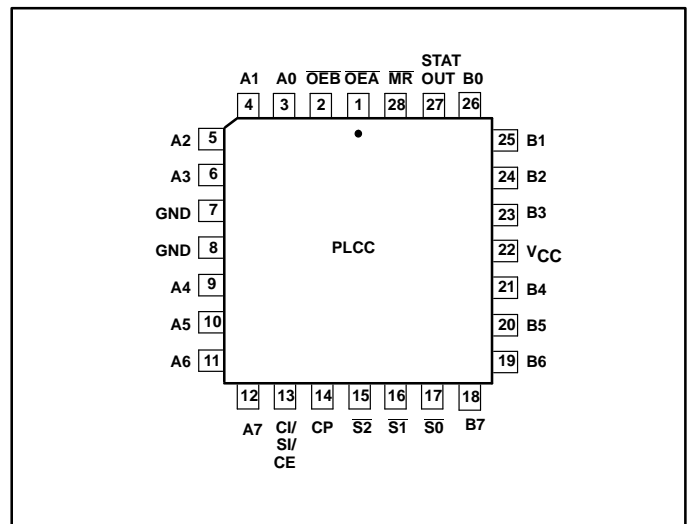

LOGIC SYMBOL

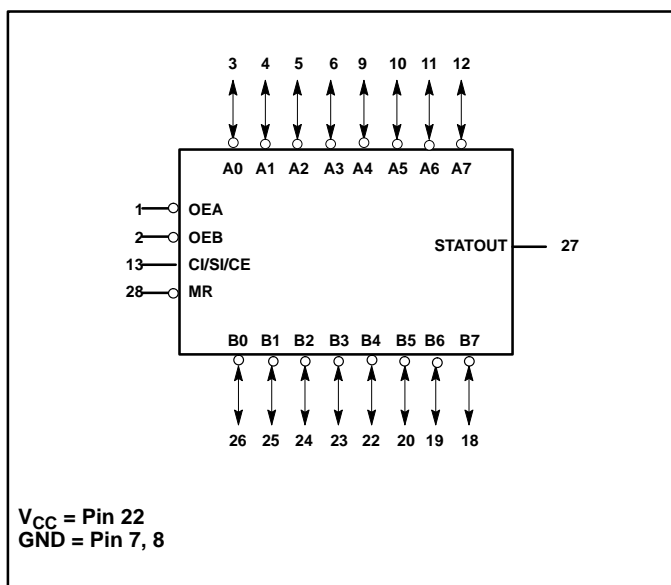

IEC/IEEE SYMBOL

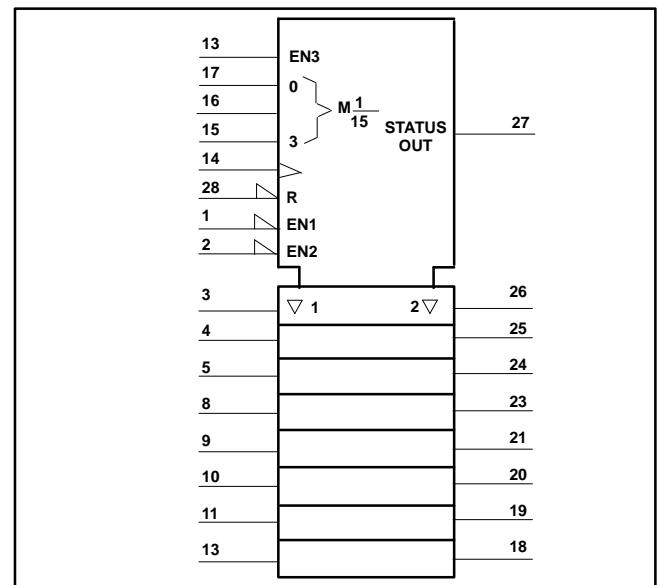

Octal shift/count registered transceiver with adder and parity (3-State)

FAST 74F807

LOGIC DIAGRAM

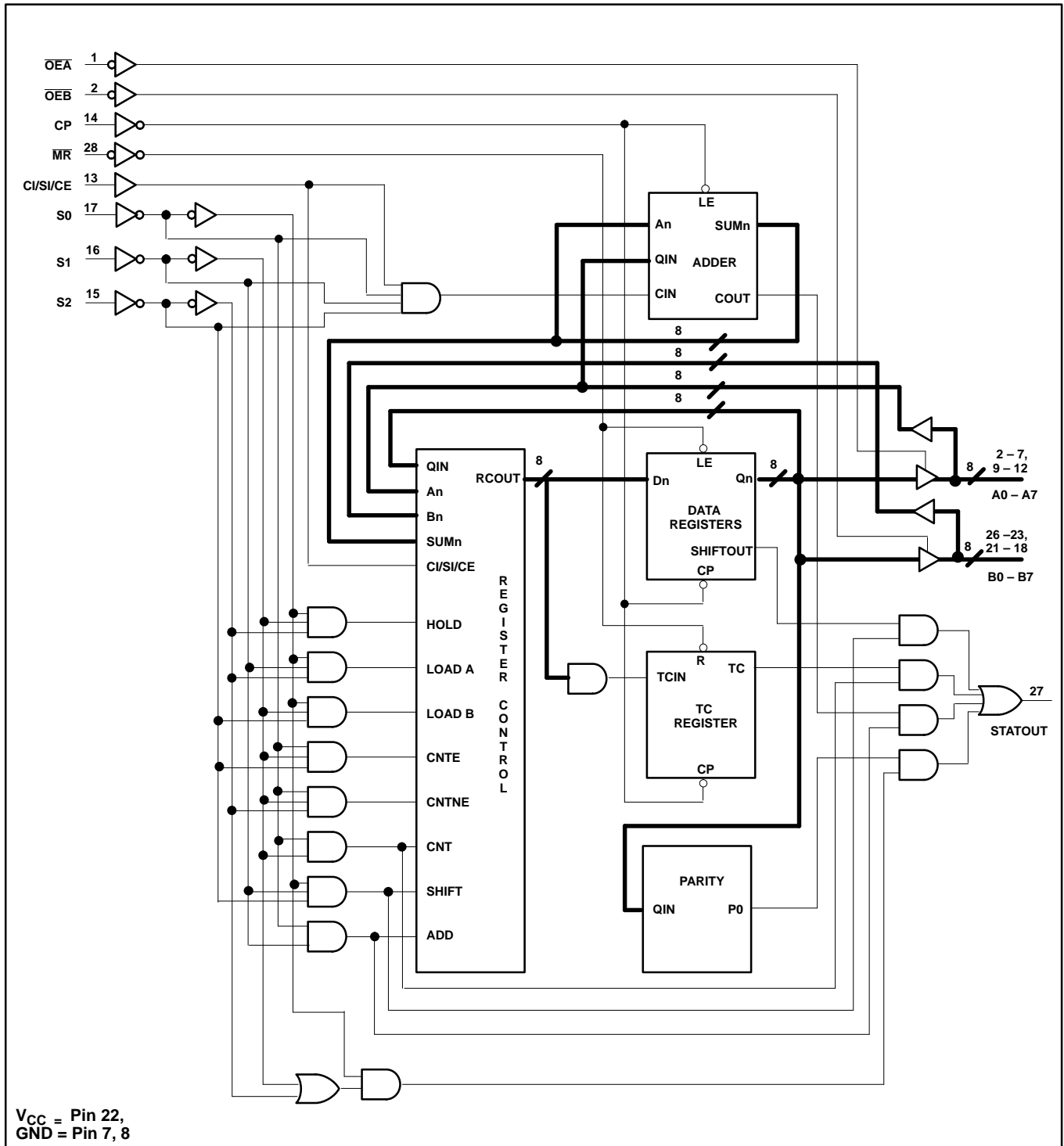

Octal shift/count registered transceiver with adder and parity (3-State)

FAST 74F807

FUNCTION TABLE

| INPUTS | | | | | | INTERNAL REGISTER | OUTPUT | OPERATING MODE |
|--------|----|----|----|----|----------|----------------------|------------|------------------------------|
| MR | CP | SO | S1 | S2 | CI/SI/CE | Qn | STATOUT | |
| L | X | X | X | X | X | L | L | Clear |
| H | ↑ | L | L | L | CI/SI/CE | CI/SI/CE + an0 + qn0 | COUT | Add mode w/carry in |
| H | ↑ | L | L | H | X | an0 + qn0 | COUT | Add mode wo/carry in |
| H | ↑ | L | H | L | H | qn0 + 1 | TC (1) | Count w/count enable (count) |
| H | X | L | H | H | L | qn0 | TC (1) | Count w/count enable (hold) |
| H | ↑ | L | H | H | X | qn0 + 1 | TC (1) | Count wo/count enable |
| H | ↑ | H | L | L | CI/SI/CE | (3) | Q7 | Shift |
| H | ↑ | H | L | H | X | An0 | parity (2) | Load A ports |
| H | ↑ | H | H | L | X | Bn0 | parity (2) | Load B ports |
| H | X | H | H | H | X | Qn0 | parity (2) | Hold |

Notes to function table

1. H = High-voltage level
2. L = Low-voltage level
3. a, b, q = Lower case indicate the state of the referenced output prior to the low-to-high clock transition
4. X = Don't care
5. Z = High impedance "off" state
6. ↑ = Low-to-high clock transition.
7. (1) = Terminal count is high when the output is a terminal count (HHHHHHHH).
8. (2) = Parity is high for odd number of internal register bits high, low for even number of internal register bits high.
9. (3) = CI/SI/CE → Q0 → Q1, etc.

OE FUNCTION TABLE

| INPUTS | | OUTPUTS | | MODE |
|--------|-----|---------------|---------------|----------------------------|
| OEa | OEb | An | Bn | |
| L | L | active output | active output | Enable A and B outputs |
| L | H | active output | input | Enable A outputs, B inputs |
| H | L | input | active output | A inputs, enable B outputs |
| H | H | input | input | A and B are inputs |

NOTE: The outputs, whether An or Bn, are equal to the INTERNAL REGISTER Qn.

ABSOLUTE MAXIMUM RATINGS (Operation beyond the limits set forth in this table may impair the useful life of the device. Unless otherwise noted, these limits are over the operating free-air temperature range.)

| SYMBOL | PARAMETER | RATING | UNIT |
|------------------|--|-------------------------|------|
| V _{CC} | Supply voltage | -0.5 to +7.0 | V |
| V _{IN} | Input voltage | -0.5 to +7.0 | V |
| I _{IN} | Input current | -30 to +5 | mA |
| V _{OUT} | Voltage applied to output in high output state | -0.5 to V _{CC} | V |
| I _{OUT} | Current applied to output in low output state | 48 | mA |
| T _{amb} | Operating free air temperature range | 0 to +70 | °C |
| T _{stg} | Storage temperature range | -65 to +150 | °C |

NOTE: When outputs are disabled the internal registers (Qn) operate as usual.

Octal shift/count registered transceiver with adder and parity (3-State)

FAST 74F807

RECOMMENDED OPERATING CONDITIONS

| SYMBOL | PARAMETER | LIMITS | | | UNIT |
|------------------|--------------------------------|--------|-----|-----|------|
| | | MIN | NOM | MAX | |
| V _{CC} | Supply voltage | 4.5 | 5.0 | 5.5 | V |
| V _{IH} | High-level input voltage | 2.0 | | | V |
| V _{IL} | Low-level input voltage | | | 0.8 | V |
| I _{IK} | Input clamp current | | | -18 | mA |
| I _{OH} | High-level output current | | | -3 | mA |
| I _{OL} | Low-level output current | | | 24 | mA |
| T _{amb} | Operating free air temperature | 0 | | +70 | °C |

DC ELECTRICAL CHARACTERISTICS

(Over recommended operating free-air temperature range unless otherwise noted.)

| SYMBOL | PARAMETER | TEST CONDITIONS ¹ | LIMITS | | | UNIT |
|------------------------------------|--|---|--------|------------------|------|------|
| | | | MIN | TYP ² | MAX | |
| V _{OH} | High-level output voltage | V _{CC} = MIN, V _{IL} = MAX, ±10%V _{CC} | 2.4 | | | V |
| | | V _{IH} = MIN, I _{OH} = MAX, ±5%V _{CC} | 2.7 | 3.4 | | V |
| V _{OL} | Low-level output voltage | V _{CC} = MIN, V _{IL} = MAX, ±10%V _{CC} | | 0.35 | 0.50 | V |
| | | V _{IH} = MIN, I _{OL} = MAX, ±5%V _{CC} | | 0.35 | 0.50 | V |
| V _{IK} | Input clamp voltage | V _{CC} = MIN, I _I = I _{IK} | | -0.73 | -1.2 | V |
| I _I | Input current at maximum input voltage | V _{CC} = MAX, V _I = 7.0V | | | 100 | μA |
| I _{IH} | High-level input current | V _{CC} = MAX, V _I = 2.7V | | | 20 | μA |
| I _{IL} | Low-level input current | V _{CC} = MAX, V _I = 0.5V | | | -20 | μA |
| I _{OZH} + I _{IH} | Off-state output current, high-level voltage applied | An, Bn V _{CC} = MAX, V _O = 2.7V | | | 50 | μA |
| I _{OZL} + I _{IL} | Off-state output current, low-level voltage applied | | | | -50 | μA |
| I _{OS} | Short-circuit output current ³ | V _{CC} = MAX | -60 | | -150 | mA |
| I _{CC} | Supply current (total) | V _{CC} = MAX | | 155 | 210 | mA |

Notes to DC electrical characteristics

- For conditions shown as MIN or MAX, use the appropriate value specified under recommended operating conditions for the applicable type.
- All typical values are at V_{CC} = 5V, T_{amb} = 25°C.
- Not more than one output should be shorted at a time. For testing I_{OS}, the use of high-speed test apparatus and/or sample-and-hold techniques are preferable in order to minimize internal heating and more accurately reflect operational values. Otherwise, prolonged shorting of a high output may raise the chip temperature well above normal and thereby cause invalid readings in other parameter tests. In any sequence of parameter tests, I_{OS} tests should be performed last.

Octal shift/count registered transceiver with adder and parity (3-State)

FAST 74F807

AC ELECTRICAL CHARACTERISTICS

| SYMBOL | PARAMETER | TEST CONDITION | LIMITS | | | | | UNIT |
|--------------------------------------|--|--------------------------|--|--------------|--------------|---|--------------|------|
| | | | T _{amb} = +25°C | | | T _{amb} = 0°C to +70°C | | |
| | | | V _{CC} = +5.0V | | | V _{CC} = +5.0V ± 10% | | |
| | | | C _L = 50pF, R _L = 500Ω | | | C _L = 50p, R _L = 500Ω | | |
| | | | MIN | TYP | MAX | MIN | MAX | |
| f _{max} | Maximum clock frequency | Waveform 1 | 100 | 115 | | 70 | | MHz |
| t _{PLH} t _{PHL} | Propagation delay CP to An or Bn (load) | Waveform 1 | 9.0 5.0 | 10.5 6.5 | 11.5 9.5 | 8.0 4.5 | 13.5 10.0 | ns |
| t _{PLH} t _{PHL} | Propagation delay CP to An or Bn (shift) | Waveform 1 | 9.0 4.5 | 10.5 6.5 | 12.5 9.5 | 8.0 4.5 | 15.0 10.0 | ns |
| t _{PLH} t _{PHL} | Propagation delay CP to An or Bn (count) | Waveform 1 | 9.0 5.0 | 11.5 6.5 | 14.0 9.5 | 8.0 4.5 | 15.5 10.0 | ns |
| t _{PLH} t _{PHL} | Propagation delay CP to Bn (add) | Waveform 1 | 9.0 5.0 | 10.5 6.5 | 11.5 9.5 | 8.0 4.5 | 13.5 10.0 | ns |
| t _{PLH} t _{PHL} | Propagation delay CP to STATOUT (load A) | Waveform 1 | 17.5 12.5 | 19.5 14.5 | 22.5 17.0 | 15.5 11.5 | 26.5 19.0 | ns |
| t _{PLH} t _{PHL} | Propagation delay CP to STATOUT (shift) | Waveform 1 | 11.0 7.0 | 13.0 8.5 | 15.5 11.5 | 9.5 6.5 | 18.0 12.0 | ns |
| t _{PLH} t _{PHL} | Propagation delay CP to STATOUT (count) | Waveform 1 | 10.5 6.5 | 12.0 8.0 | 15.0 11.0 | 9.0 6.0 | 17.0 11.5 | ns |
| t _{PLH} t _{PHL} | Propagation delay CP to STATOUT (add) | Waveform 1 | 13.0 8.5 | 15.0 10.5 | 18.0 13.0 | 11.5 8.0 | 20.5 14.0 | ns |
| t _{PHL} | Propagation delay MR to An or Bn (load A) | Waveform 3 | 6.5 | 8.0 | 11.0 | 6.0 | 12.0 | ns |
| t _{PHL} | Propagation delay MR to STATOUT (load A) | Waveform 3 | 14.0 | 16.0 | 18.5 | 13.0 | 20.5 | ns |
| t _{PHL} | Propagation delay MR to STATOUT (shift) | Waveform 3 | 8.5 | 10.0 | 12.5 | 8.0 | 14.0 | ns |
| t _{PHL} | Propagation delay MR to STATOUT (count) | Waveform 3 | 8.5 | 10.0 | 12.5 | 8.0 | 14.0 | ns |
| t _{PHL} | Propagation delay MR to STATOUT (add) | Waveform 3 | 10.5 | 12.0 | 14.5 | 9.5 | 16.0 | ns |
| t _{PLH} t _{PHL} | Propagation delay An to STATOUT (add) | Waveform 4 | 6.5 8.0 | 14.0 14.0 | 23.5 22.5 | 5.5 7.5 | 26.5 27.0 | ns |
| t _{PLH} t _{PHL} | Propagation delay CI/SI/CE to STATOUT | Waveform 4 | 19.5 21.0 | 21.5 22.5 | 24.0 25.5 | 17.0 20.0 | 28.0 29.5 | ns |
| t _{PLH} t _{PHL} | Propagation delay Sn to STATOUT (load A) | Waveform 4 | 8.0 7.5 | 10.0 11.5 | 12.5 15.5 | 7.0 7.0 | 14.5 17.0 | ns |
| t _{PLH} t _{PHL} | Propagation delay Sn to STATOUT (load B) | Waveform 4 | 6.5 8.0 | 10.0 12.0 | 13.0 15.0 | 5.5 7.0 | 15.0 16.5 | ns |
| t _{PLH} t _{PHL} | Propagation delay Sn to STATOUT (add) | Waveform 4 | 19.0 18.5 | 21.0 20.0 | 23.5 23.0 | 17.0 17.5 | 27.5 26.0 | ns |
| t _{PLH} t _{PHL} | Propagation delay Sn to STATOUT (shift) | Waveform 4 | 6.0 8.0 | 8.0 9.5 | 10.5 12.0 | 5.0 7.0 | 12.0 13.5 | ns |
| t _{PZH} t _{PZL} | Output enable time, OE \bar{A} to An or OE \bar{B} to Bn | Waveform 6 Waveform 7 | 2.5 4.0 | 4.5 5.5 | 7.0 8.5 | 2.0 3.5 | 8.0 9.0 | ns |
| t _{PHZ} t _{PLZ} | Output disable time, OE \bar{A} to An or OE \bar{B} to Bn | Waveform 6 Waveform 7 | 2.0 3.5 | 4.5 5.5 | 7.5 8.5 | 2.0 3.0 | 9.0 9.5 | ns |

Octal shift/count registered transceiver with adder and parity (3-State)

FAST 74F807

AC SETUP REQUIREMENTS

| SYMBOL | PARAMETER | TEST CONDITION | LIMITS | | | | | UNIT |
|--|--|----------------|---|-----|-----|--|-----|------|
| | | | T _{amb} = +25°C V _{CC} = +5.0V C _L = 50pF, R _L = 500Ω | | | T _{amb} = 0°C to +70°C V _{CC} = +5.0V ± 10% C _L = 50pF, R _L = 500Ω | | |
| | | | MIN | TYP | MAX | MIN | MAX | |
| t _{SU} (H) t _{SU} (L) | Setup time, high or low An, Bn to CP (load) | Waveform 5 | 6.0 9.5 | | | 6.5 12.0 | | ns |
| t _H (H) t _H (L) | Hold time, high or low An, Bn to CP (load) | Waveform 5 | 0.0 0.0 | | | 0.0 0.0 | | ns |
| t _{SU} (H) t _{SU} (L) | Setup time, high or low An, Bn to CP (add) | Waveform 5 | 10.5 16.5 | | | 12.0 21.5 | | ns |
| t _H (H) t _H (L) | Hold time, high or low An, Bn to CP (add) | Waveform 5 | 0.0 0.0 | | | 0.0 0.0 | | ns |
| t _{SU} (H) t _{SU} (L) | Setup time, high or low Sn to CP (add) | Waveform 5 | 16.0 16.0 | | | 20.0 28.5 | | ns |
| t _{SU} (H) t _{SU} (L) | Setup time, high or low Sn to CP (count) | Waveform 5 | 16.5 19.5 | | | 19.0 22.5 | | ns |
| t _{SU} (H) t _{SU} (L) | Setup time, high or low Sn to CP (shift) | Waveform 5 | 11.0 7.0 | | | 13.0 8.0 | | ns |
| t _{SU} (H) t _{SU} (L) | Setup time, high or low Sn to CP (load) | Waveform 5 | 17.5 6.5 | | | 20.5 7.0 | | ns |
| t _H (H) t _H (L) | Hold time, high or low Sn to CP (all modes) | Waveform 5 | 0.0 0.0 | | | 0.0 0.0 | | ns |
| t _{SU} (H) t _{SU} (L) | Setup time, high or low CI/SI/CE to CP (add) | Waveform 5 | 10.0 18.0 | | | 11.5 22.0 | | ns |
| t _{SU} (H) t _{SU} (L) | Setup time, high or low CI/SI/CE to CP (count) | Waveform 5 | 8.5 16.0 | | | 10.0 18.5 | | ns |
| t _{SU} (H) t _{SU} (L) | Setup time, high or low CI/SI/CE to CP (shift) | Waveform 5 | 5.0 9.0 | | | 5.5 10.5 | | ns |
| t _H (H) t _H (L) | Hold time, high or low CI/SI/CE to CP (all modes) | Waveform 5 | 0.0 0.0 | | | 0.0 0.0 | | ns |
| t _W (H) t _W (L) | CP pulse width, High or low | Waveform 1 | 5.5 4.5 | | | 6.0 4.5 | | ns |
| t _W (L) | MR pulse width, low | Waveform 3 | 4.5 | | | 5.0 | | ns |
| t _{rec} | Recovery time, MR to CP | Waveform 2 | 2.0 | | | 2.0 | | ns |

Octal shift/count registered transceiver with adder and parity (3-State)

FAST 74F807

AC WAVEFORMS

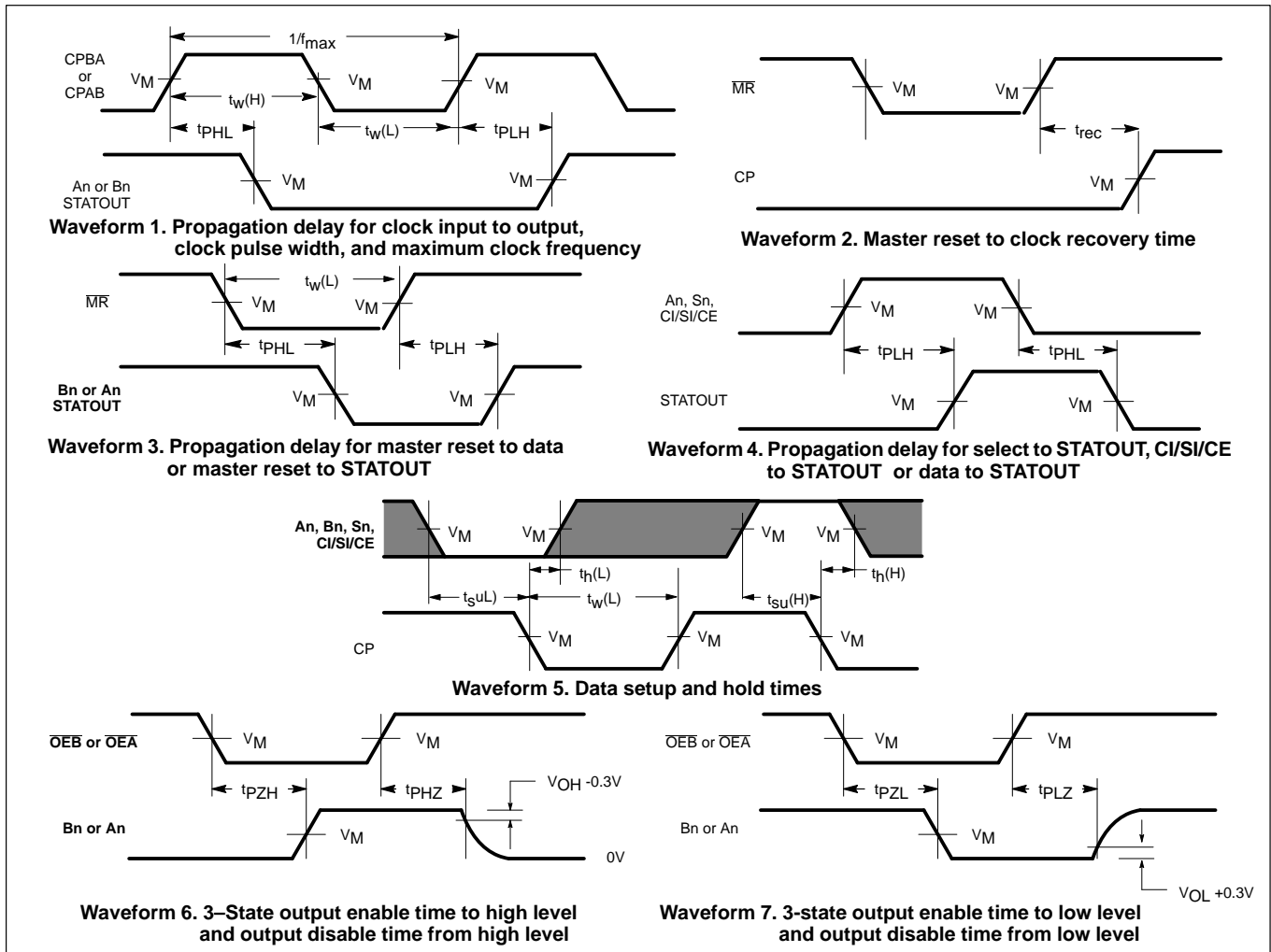

Notes to AC waveforms

- For all waveforms, $V_M = 1.5V$.
- The shaded areas indicate when the input is permitted to change for predictable output performance.

TEST CIRCUIT AND WAVEFORMS

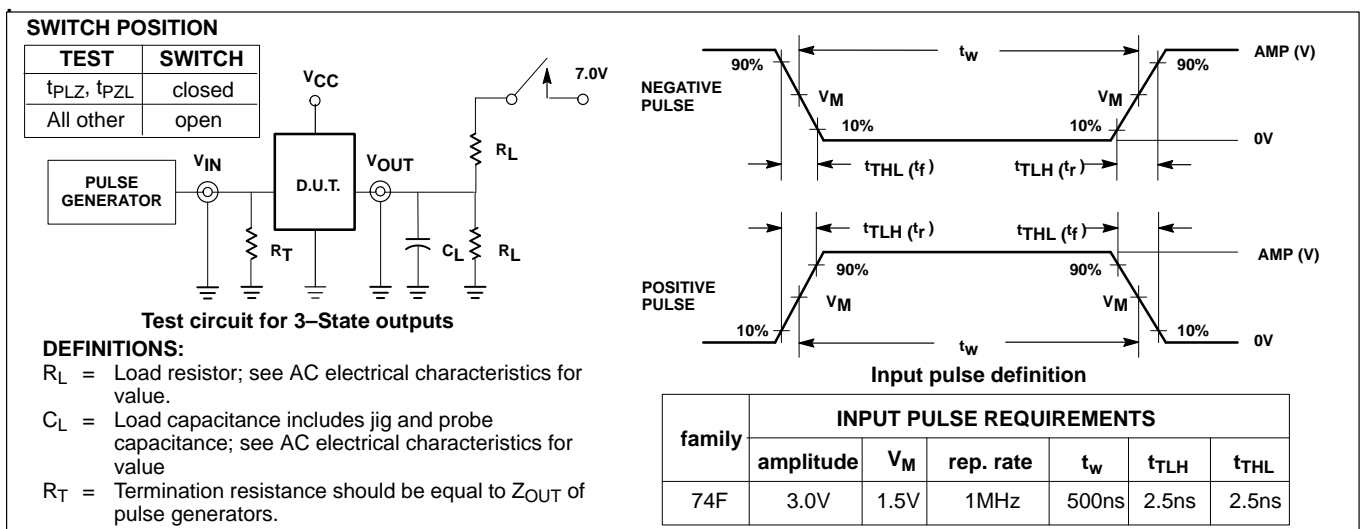



LittleDiode supplies new, hard to find or obsolete electronic components and semiconductors all over the world.

With over two million different components listed you are sure to find the part you need.

Feel free to visit us today at our online store:

LittleDiode.com

Looking forward to providing you with the best possible service.