

# DATA SHEET

## **74F646A**

Octal transceiver/register, non-inverting  
(3-State)

## **74F648A**

Octal transceiver/register, inverting  
(3-State)

Product data

Replaces 74F646/646A/74F648/648A dated 1990 Sep 25

2003 Feb 04

## Transceivers/registers

## 74F646A/74F648A

**74F646A:** Octal transceiver/register, non-inverting (3-State)

**74F648A:** Octal transceiver/register, inverting (3-State)

## FEATURES

- Combines 74F245 and two 74F374 type functions in one chip
- High impedance base inputs for reduced loading (70  $\mu$ A in HIGH and LOW states)
- Independent registers for A and B buses
- Multiplexed real-time and stored data
- Choice of non-inverting and inverting data paths
- Controlled ramp outputs for 74F646A/74F648A
- 3-state outputs
- 300 mil wide 24-pin slim DIP package

## DESCRIPTION

The 74F646A and 74F648A transceivers/registers consist of bus transceiver circuits with 3-state outputs, D-type flip-flops, and control circuitry arranged for multiplexed transmission of data directly from the input bus or the internal registers. Data on the A or B bus will be clocked into the registers as the appropriate clock pin goes HIGH. Output enable ( $\overline{OE}$ ) and DIR pins are provided to control the transceiver function. In the transceiver mode, data present at the high impedance port may be stored in either the A or B register or both.

The select pins (SAB, SBA) determine whether data is stored or transferred through the device in real-time. The DIR determines which bus will receive data when the  $\overline{OE}$  is active LOW. In the isolation mode ( $\overline{OE}$  = HIGH), data from bus A may be stored in the B register and/or data from bus B may be stored in the A register. When an output function is disabled, the input function is still enabled and may be used to store and transmit data. Only one of the two buses, A or B may be driven at a time.

TYPE	TYPICAL $f_{max}$	TYPICAL SUPPLY CURRENT (TOTAL)
74F646A, 74F648A	185 MHz	105 mA

## ORDERING INFORMATION

DESCRIPTION	ORDER CODE	PKG DWG #
	COMMERCIAL RANGE $V_{CC} = 5 V \pm 10\%$ , $T_{amb} = 0^\circ C$ to $+70^\circ C$	
24-pin plastic slim DIP (300 mil)	N74F646AN, N74F648AN	SOT222-1
24-pin plastic SOL	N74F646AD, N74F648AD	SOT137-1

## INPUT AND OUTPUT LOADING AND FAN-OUT TABLE

PINS	DESCRIPTION	74F (U.L.) HIGH/LOW	LOAD VALUE HIGH / LOW
A0-A7, B0-B7	A and B inputs	3.5 / 0.116	70 $\mu$ A / 70 $\mu$ A
CPAB	A-to-B clock input	1.0 / 0.033	20 $\mu$ A / 20 $\mu$ A
CPBA	B-to-A clock input	1.0 / 0.033	20 $\mu$ A / 20 $\mu$ A
SAB	A-to-B select input	1.0 / 0.033	20 $\mu$ A / 20 $\mu$ A
SBA	B-to-A select input	1.0 / 0.033	20 $\mu$ A / 20 $\mu$ A
DIR	Data flow directional control enable input	1.0 / 0.033	20 $\mu$ A / 20 $\mu$ A
$\overline{OE}$	Output enable input	1.0 / 0.033	20 $\mu$ A / 20 $\mu$ A
A0 - A7, B0 - B7	A, B outputs for N74F646A/N74F648A	750 / 80	15 mA / 48 mA

**NOTE:** One (1.0) FAST unit load is defined as: 20  $\mu$ A in the HIGH state and 0.6 mA in the LOW state.

# Transceivers/registers

# 74F646A/74F648A

## PIN CONFIGURATION

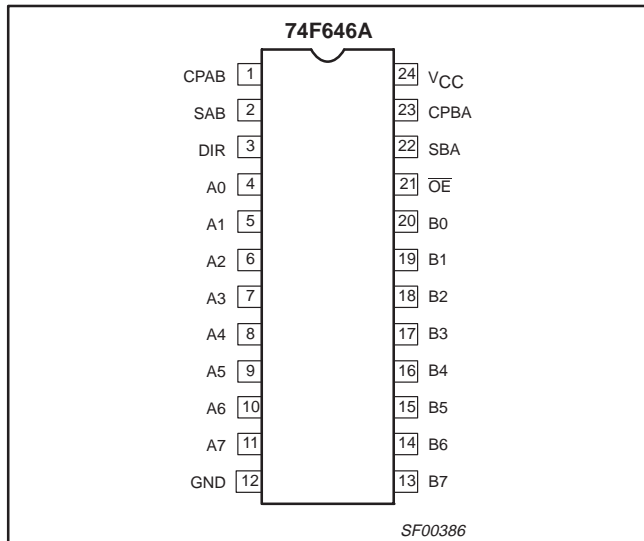

## IEC/IEEE SYMBOL

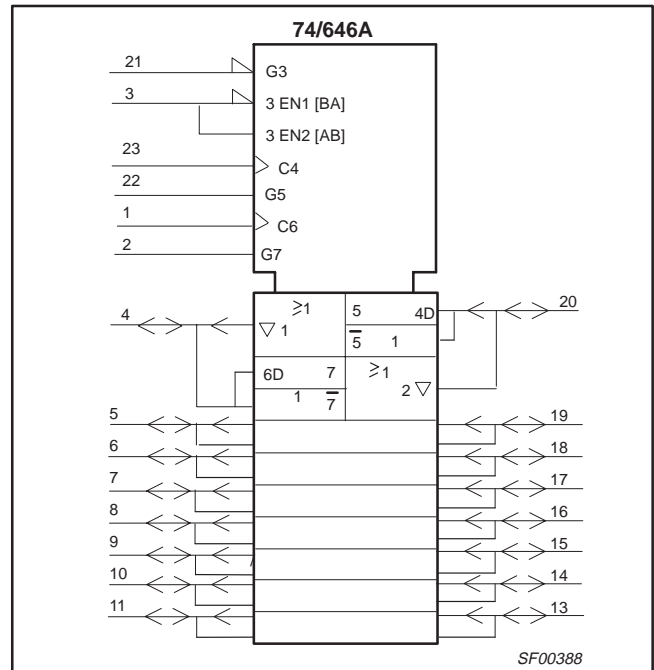

## LOGIC SYMBOL

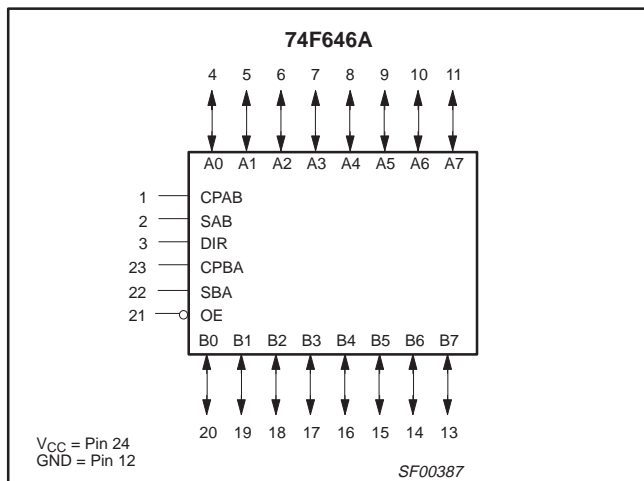

## LOGIC DIAGRAM

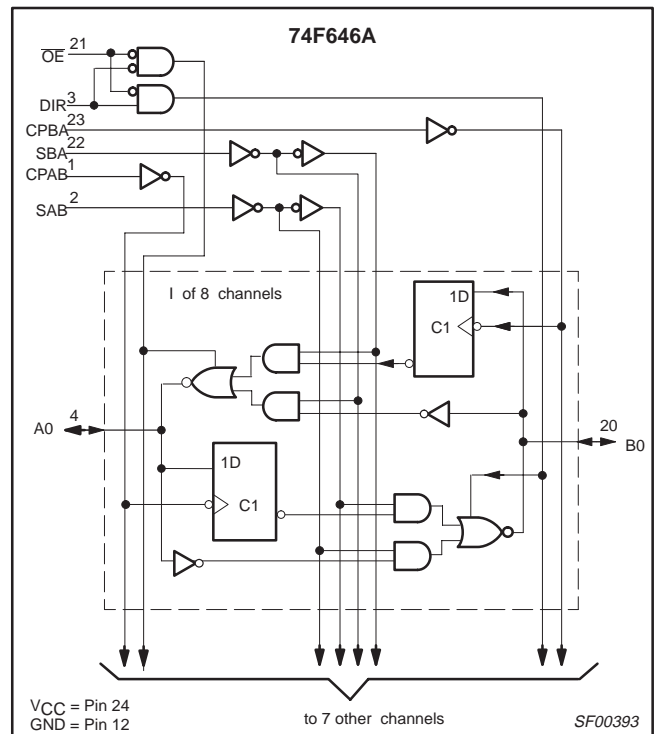



## Transceivers/registers

## 74F646A/74F648A

## FUNCTION TABLE

INPUTS						DATA I/O		OPERATING MODE	
OE	DIR	CPAB	CPBA	SAB	SBA	An	Bn	74F646A	74F648A
X	X	↑	X	X	X	Input	Unspecified*	Store A, B unspecified*	Store A, B unspecified*
X	X	X	↑	X	X	Unspecified*	Input	Store B, A unspecified*	Store B, A unspecified*
H	X	↑	↑	X	X	Input	Input	Store A and B data	Store A and B data
H	X	H or L	H or L	X	X	Input	Input	Isolation, hold storage	Isolation, hold storage
L	L	X	X	X	L	Output	Input	Real time B data to A bus	Real time $\bar{B}$ data to A bus
L	L	X	H or L	X	H	Output	Input	Stored B data to A bus	Stored $\bar{B}$ data to A bus
L	H	X	X	L	X	Input	Output	Real time A data to B bus	Real time $\bar{A}$ data to B bus
L	H	H or L	X	H	X	Input	Output	Stored A data to B bus	Stored $\bar{A}$ data to B bus

## NOTES:

1. H = High-voltage level
2. L = Low-voltage level
3. X = Don't care
4. ↑ = LOW-to-HIGH clock transition
5. \* = The data output function may be enabled or disabled by various signals at the  $\overline{OE}$  and DIR inputs. Data input functions are always enabled, i.e., data at the bus pins will be stored on every LOW-to-HIGH transition of the clock.

## ABSOLUTE MAXIMUM RATINGS

Operation beyond the limit set forth in this table may impair the useful life of the device.  
Unless otherwise noted these limits are over the operating free air temperature range.

SYMBOL	PARAMETER	RATING	UNIT
$V_{CC}$	Supply voltage	-0.5 to +7.0	V
$V_{IN}$	Input voltage	-0.5 to +7.0	V
$I_{IN}$	Input current	-30 to +5	mA
$V_{OUT}$	Voltage applied to output in HIGH output state	-0.5 to $V_{CC}$	V
$I_{OUT}$	Current applied to output in LOW output state	72	mA
$T_{amb}$	Operating free air temperature range	0 to +70	°C
$T_{stg}$	Storage temperature range	-65 to +150	°C

## RECOMMENDED OPERATING CONDITIONS

SYMBOL	PARAMETER	LIMITS			UNIT
		MIN	NOM	MAX	
$V_{CC}$	Supply voltage	4.5	5.0	5.5	V
$V_{IH}$	HIGH-level input voltage	2.0	-	-	V
$V_{IL}$	LOW-level input voltage	-	-	0.8	V
$I_{Ik}$	Input clamp current	-	-	-18	mA
$I_{OH}$	HIGH-level output current	-	-	-15	mA
$I_{OL}$	LOW-level output current	-	-	48	mA
$T_{amb}$	Operating free air temperature range	0	-	+70	°C

# Transceivers/registers

# 74F646A/74F648A

The following examples demonstrate the four fundamental bus-management functions that can be performed with the 74F646A and 74F648A. The select pins determine whether data is stored or transferred through the device in real time. The output enable pins determine the direction of the data flow.

## BUS MANAGEMENT FUNCTIONS

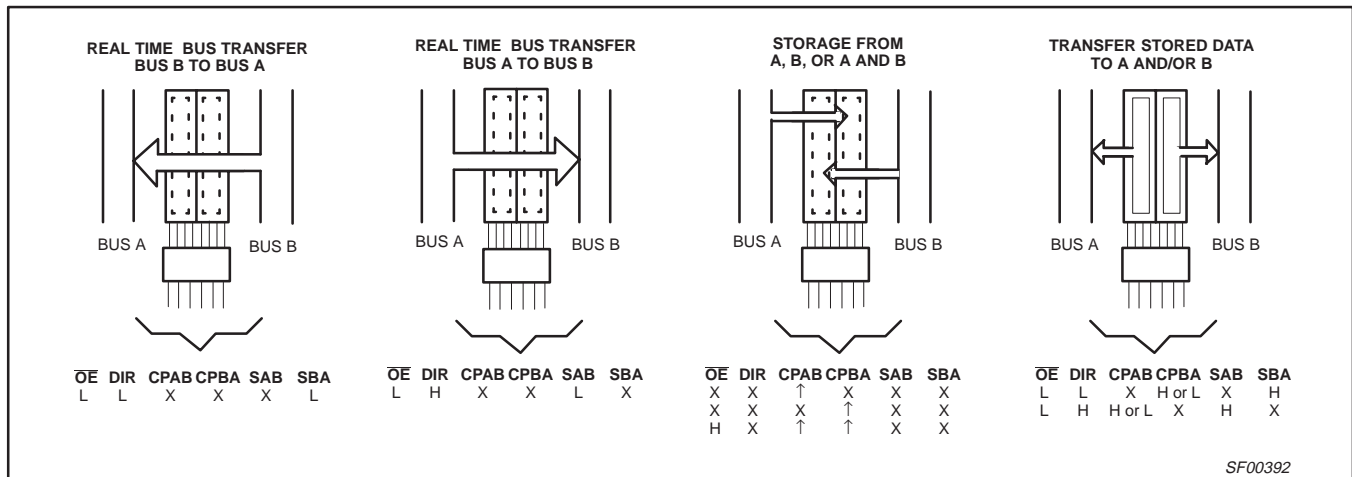

## Transceivers/registers

## 74F646A/74F648A

**DC ELECTRICAL CHARACTERISTICS**

(Over recommended operating free-air temperature range unless otherwise noted.)

SYMBOL	PARAMETER		TEST CONDITIONS <sup>1</sup>		LIMITS			UNIT	
					MIN	TYP <sup>2</sup>	MAX		
V <sub>OH</sub>	HIGH-level output voltage		V <sub>CC</sub> = MIN, V <sub>IL</sub> = MAX, V <sub>IH</sub> = MIN	I <sub>OH</sub> = -3 mA	±10%V <sub>CC</sub>	2.4	-	-	V
					±5%V <sub>CC</sub>	2.7	3.4	-	V
				I <sub>OH</sub> = -15 mA	±10%V <sub>CC</sub>	2.0	-	-	V
V <sub>OL</sub>	LOW-level output voltage		V <sub>CC</sub> = MIN, V <sub>IL</sub> = MAX, V <sub>IH</sub> = MIN	I <sub>OL</sub> = 48 mA	±10%V <sub>CC</sub>	-	0.38	0.55	V
V <sub>IK</sub>	Input clamp voltage		V <sub>CC</sub> = MIN, I <sub>I</sub> = I <sub>IK</sub>		-	-0.73	-1.2	V	
I <sub>I</sub>	Input current at maximum input voltage	others	V <sub>CC</sub> = 0.0 V, V <sub>I</sub> = 7.0 V		-	-	100	μA	
		A0-A7, B0-B7	V <sub>CC</sub> = MAX, V <sub>I</sub> = 5.5 V		-	-	1	mA	
I <sub>IH</sub>	HIGH-level input current	OE, DIR, CPAB, CPBA, SAB, SBA	V <sub>CC</sub> = MAX, V <sub>I</sub> = 2.7 V		-	-	20	μA	
I <sub>IL</sub>	LOW-level input current		V <sub>CC</sub> = MAX, V <sub>I</sub> = 0.5 V		-	-	-20	μA	
I <sub>OZH</sub> + I <sub>IH</sub>	Off-state output current, HIGH-level voltage applied	A0-A7, B0-B7	V <sub>CC</sub> = MAX, V <sub>O</sub> = 2.7 V		-	-	70	μA	
I <sub>OZL</sub> + I <sub>IL</sub>	Off-state output current, LOW-level voltage applied		V <sub>CC</sub> = MAX, V <sub>O</sub> = 0.5 V		-	-	-70	μA	
I <sub>O</sub>	Output current <sup>3</sup>		V <sub>CC</sub> = MAX, V <sub>O</sub> = 2.25 V		-60	-	-150	mA	
I <sub>CC</sub>	Supply current (total)	I <sub>CCH</sub>	V <sub>CC</sub> = MAX		-	100	145	mA	
		I <sub>CCL</sub>			-	110	155	mA	
		I <sub>CCZ</sub>			-	105	155	mA	

**NOTES:**

- For conditions shown as MIN or MAX, use the appropriate value specified under recommended operating conditions for the applicable type. Unless otherwise specified, V<sub>X</sub> = V<sub>CC</sub> for all test conditions.
- All typical values are at V<sub>CC</sub> = 5 V, T<sub>amb</sub> = 25 °C.
- I<sub>O</sub> is tested under conditions that produce current approximately one half of the true short-circuit output current (I<sub>OS</sub>).

## Transceivers/registers

## 74F646A/74F648A

## AC ELECTRICAL CHARACTERISTICS FOR 74F646A

SYMBOL	PARAMETER	TEST CONDITION	LIMITS					UNIT
			T <sub>amb</sub> = +25 °C V <sub>CC</sub> = +5.0 V C <sub>L</sub> = 50 pF, R <sub>L</sub> = 500 Ω			T <sub>amb</sub> = 0 °C to +70 °C V <sub>CC</sub> = +5.0 V ± 10% C <sub>L</sub> = 50 pF, R <sub>L</sub> = 500 Ω		
			MIN	TYP	MAX	MIN	MAX	
f <sub>max</sub>	Maximum clock frequency	Waveform 1	165	185		150		MHz
t <sub>PLH</sub> t <sub>PHL</sub>	Propagation delay CPAB or CPBA to An or Bn	Waveform 1	5.5 4.5	7.0 7.0	10.5 9.5	4.5 4.0	11.0 10.0	ns
t <sub>PLH</sub> t <sub>PHL</sub>	Propagation delay An to Bn or Bn to An	Waveform 2	4.0 2.0	6.0 5.0	9.0 8.0	3.5 2.0	10.0 8.0	ns
t <sub>PLH</sub> t <sub>PHL</sub>	Propagation delay SAB or SBA to An or Bn	Waveform 2, 3	4.5 3.5	6.5 8.0	9.5 10.0	4.0 3.0	10.0 11.5	ns
t <sub>PZH</sub> t <sub>PZL</sub>	Output enable time OE to An or Bn	Waveform 5 Waveform 6	3.0 3.0	5.5 5.5	9.0 10.0	2.5 2.5	10.0 10.5	ns
t <sub>PZH</sub> t <sub>PZL</sub>	Output enable time DIR to An or Bn	Waveform 5 Waveform 6	3.0 3.5	5.0 6.0	8.0 8.5	3.0 3.0	8.5 9.5	ns
t <sub>PHZ</sub> t <sub>PLZ</sub>	Output disable time OE to An or Bn	Waveform 5 Waveform 6	1.5 2.5	4.0 5.5	6.5 8.0	1.0 2.0	8.0 9.5	ns
t <sub>PHZ</sub> t <sub>PLZ</sub>	Output disable time DIR to An or Bn	Waveform 5 Waveform 6	2.0 3.0	4.5 5.0	7.5 8.0	1.5 2.0	8.5 8.5	ns

## AC SET-UP REQUIREMENTS FOR 74F646A

SYMBOL	PARAMETER	TEST CONDITION	LIMITS					UNIT
			T <sub>amb</sub> = +25 °C V <sub>CC</sub> = +5.0 V C <sub>L</sub> = 50 pF, R <sub>L</sub> = 500 Ω			T <sub>amb</sub> = 0 °C to +70 °C V <sub>CC</sub> = +5.0 V ± 10% C <sub>L</sub> = 50 pF, R <sub>L</sub> = 500 Ω		
			MIN	TYP	MAX	MIN	MAX	
t <sub>su</sub> (H) t <sub>su</sub> (L)	Set-up time, HIGH or LOW An or Bn to CPAB or CPBA	Waveform 4	3.5 4.0			4.0 4.5		ns
t <sub>h</sub> (H) t <sub>h</sub> (L)	Hold time, HIGH or LOW An or Bn to CPAB or CPBA	Waveform 4	0 0			0 0		ns
t <sub>w</sub> (H) t <sub>w</sub> (L)	Pulse width, HIGH or LOW CPAB or CPBA	Waveform 1	3.5 3.5			4.5 4.0		ns

## Transceivers/registers

## 74F646A/74F648A

## AC ELECTRICAL CHARACTERISTICS FOR 74F648A

SYMBOL	PARAMETER	TEST CONDITION	LIMITS					UNIT
			T <sub>amb</sub> = +25°C V <sub>CC</sub> = +5.0 V C <sub>L</sub> = 50 pF, R <sub>L</sub> = 500 Ω			T <sub>amb</sub> = 0°C to +70°C V <sub>CC</sub> = +5.0 V ± 10% C <sub>L</sub> = 50 pF, R <sub>L</sub> = 500 Ω		
			MIN	TYP	MAX	MIN	MAX	
f <sub>max</sub>	Maximum clock frequency	Waveform 1	160	185		135		ns
t <sub>PLH</sub> t <sub>PHL</sub>	Propagation delay CPAB or CPBA to An or Bn	Waveform 1	5.0 5.5	7.0 7.5	9.5 10.0	4.5 4.5	10.5 10.5	ns
t <sub>PLH</sub> t <sub>PHL</sub>	Propagation delay An to Bn or Bn to An	Waveform 3	2.5 4.0	4.5 6.0	7.5 8.5	2.0 4.0	8.5 9.5	ns
t <sub>PLH</sub> t <sub>PHL</sub>	Propagation delay SAB or SBA to An or Bn	Waveform 2, 3	4.0 4.5	7.0 7.0	9.5 9.5	3.5 4.5	11.5 10.0	ns
t <sub>PZH</sub> t <sub>PZL</sub>	Output enable time OE to An or Bn	Waveform 5 Waveform 6	3.5 4.5	6.5 6.5	10.0 10.0	3.5 4.0	11.0 11.5	ns
t <sub>PZH</sub> t <sub>PZL</sub>	Output enable time DIR to An or Bn	Waveform 5 Waveform 6	3.5 4.0	5.5 6.5	8.5 9.5	3.0 4.0	9.0 10.0	ns
t <sub>PHZ</sub> t <sub>PLZ</sub>	Output disable time OE to An or Bn	Waveform 5 Waveform 6	2.5 4.0	4.0 6.5	6.5 9.0	2.0 3.5	8.0 10.0	ns
t <sub>PHZ</sub> t <sub>PLZ</sub>	Output disable time DIR to An or Bn	Waveform 5 Waveform 6	2.5 2.5	5.0 5.0	8.5 8.0	2.0 3.5	9.0 9.0	ns

## AC SET-UP REQUIREMENTS FOR 74F648A

SYMBOL	PARAMETER	TEST CONDITION	LIMITS					UNIT
			T <sub>amb</sub> = +25 °C V <sub>CC</sub> = +5.0 V C <sub>L</sub> = 50 pF, R <sub>L</sub> = 500 Ω			T <sub>amb</sub> = 0 °C to +70 °C V <sub>CC</sub> = +5.0 V ± 10% C <sub>L</sub> = 50 pF, R <sub>L</sub> = 500 Ω		
			MIN	TYP	MAX	MIN	MAX	
t <sub>su</sub> (H) t <sub>su</sub> (L)	Set-up time, HIGH or LOW An or Bn to CPAB or CPBA	Waveform 4	4.0 4.0			4.5 4.5		ns
t <sub>h</sub> (H) t <sub>h</sub> (L)	Hold time, HIGH or LOW An or Bn to CPAB or CPBA	Waveform 4	0 0			0 0		ns
t <sub>w</sub> (H) t <sub>w</sub> (L)	Pulse width, HIGH or LOW CPAB or CPBA	Waveform 1	3.5 3.5			4.0 3.5		ns

Transceivers/registers

74F646A/74F648A

AC WAVEFORMS

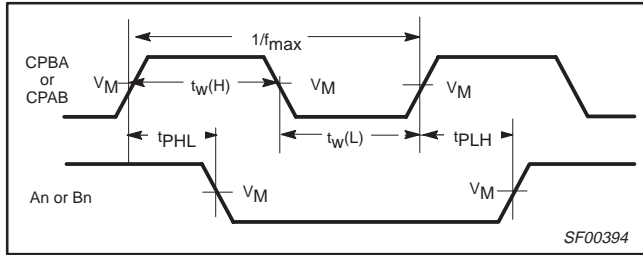

Waveform 1. Propagation delay for clock input to output clock pulse width, and maximum clock frequency

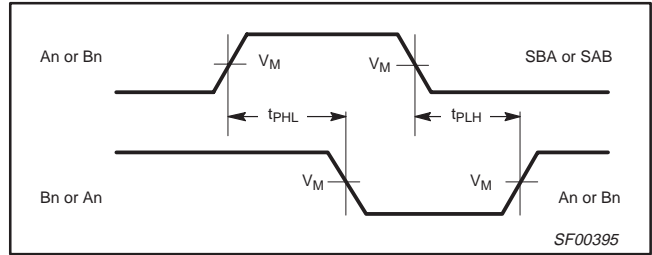

Waveform 2. Propagation delay for An to Bn or Bn to An and SAB or SBA to An or Bn

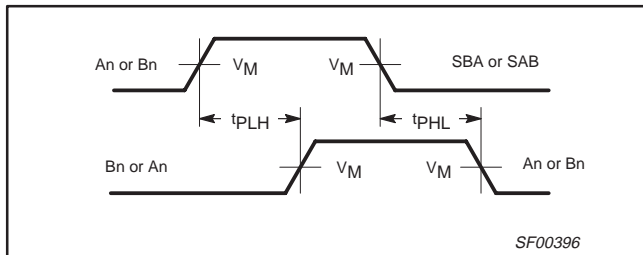

Waveform 3. Propagation delay for An to Bn or Bn to An and SAB or SBA to An or Bn

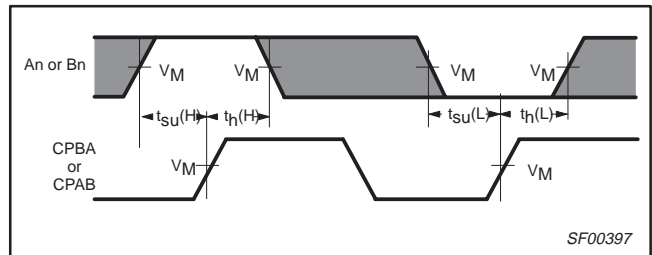

Waveform 4. Data set-up time and hold times

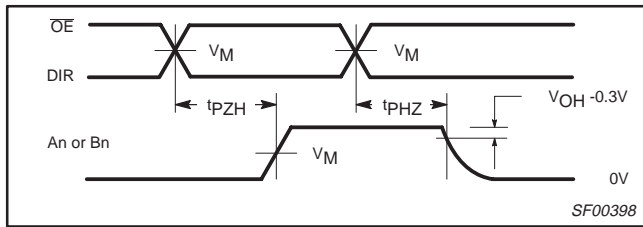

Waveform 5. 3-state output enable time to HIGH level and output disable time from HIGH level

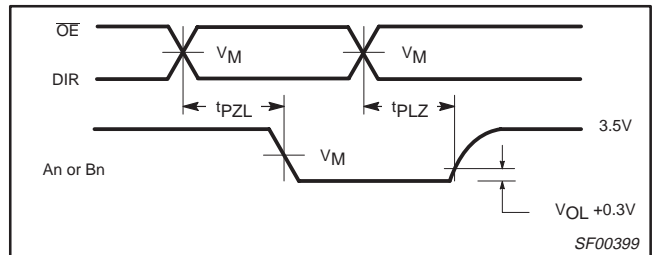

Waveform 6. 3-state output enable time to LOW level and output disable time from LOW level

NOTES:

1. For all waveforms,  $V_M = 1.5\text{ V}$ .
2. The shaded areas indicate when the input is permitted to change for predictable output performance.

# Transceivers/registers

# 74F646A/74F648A

## TEST CIRCUIT AND WAVEFORM

**Test Circuit for Open Collector Outputs**

**SWITCH POSITION**

TEST	SWITCH
$t_{PLZ}$	closed
$t_{PZL}$	closed
All other	open

**DEFINITIONS:**  
 $R_L$  = Load resistor; see AC electrical characteristics for value.  
 $C_L$  = Load capacitance includes jig and probe capacitance; see AC electrical characteristics for value.  
 $R_T$  = Termination resistance should be equal to  $Z_{OUT}$  of pulse generators.

**Input Pulse Definition**

family	INPUT PULSE REQUIREMENTS					
	amplitude	$V_M$	rep. rate	$t_w$	$t_{TLH}$	$t_{THL}$
74F	3.0V	1.5V	1MHz	500ns	2.5ns	2.5ns

SF00128

Transceivers/registers

74F646A/74F648A

DIP24: plastic dual in-line package; 24 leads (300 mil)

SOT222-1

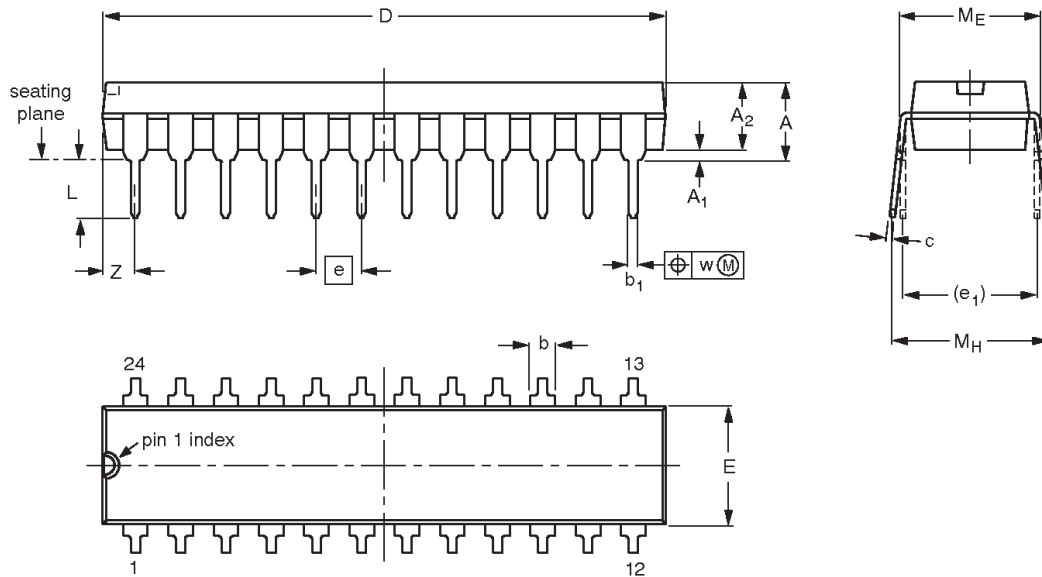

DIMENSIONS (millimetre dimensions are derived from the original inch dimensions)

UNIT	A max.	A <sub>1</sub> min.	A <sub>2</sub> max.	b	b <sub>1</sub>	c	D <sup>(1)</sup>	E <sup>(1)</sup>	e	e <sub>1</sub>	L	M <sub>E</sub>	M <sub>H</sub>	w	Z <sup>(1)</sup> max.
mm	4.70	0.38	3.94	1.63 1.14	0.56 0.43	0.36 0.25	31.9 31.5	6.73 6.25	2.54	7.62	3.51 3.05	8.13 7.62	10.03 7.62	0.25	2.05
inches	0.185	0.015	0.155	0.064 0.045	0.022 0.017	0.014 0.010	1.256 1.240	0.265 0.246	0.100	0.300	0.138 0.120	0.32 0.30	0.395 0.300	0.01	0.081

Note

1. Plastic or metal protrusions of 0.01 inches maximum per side are not included.

OUTLINE VERSION	REFERENCES				EUROPEAN PROJECTION	ISSUE DATE
	IEC	JEDEC	EIAJ			
SOT222-1		MS-001				99-04-28 99-12-27

Transceivers/registers

74F646A/74F648A

SO24: plastic small outline package; 24 leads; body width 7.5 mm

SOT137-1

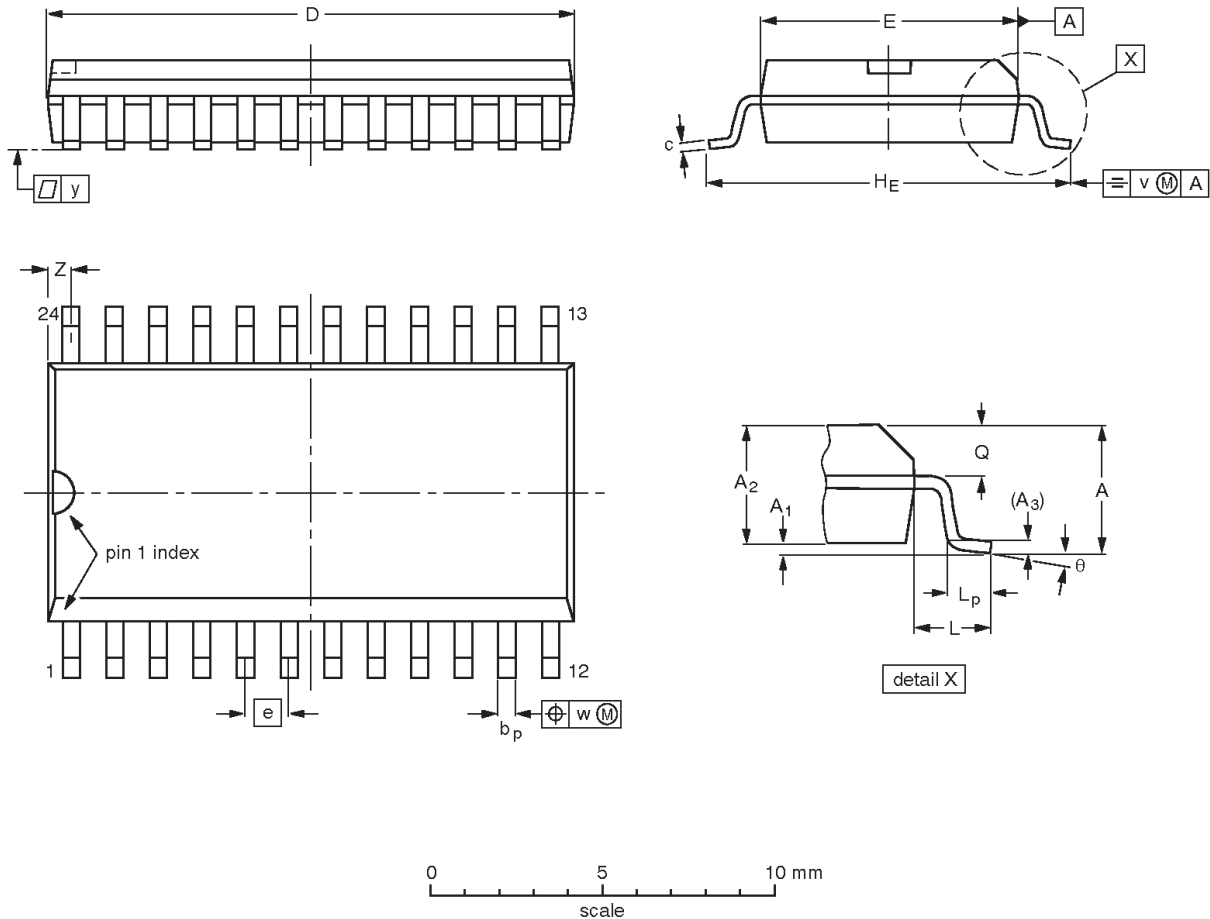

**DIMENSIONS (inch dimensions are derived from the original mm dimensions)**

UNIT	A max.	A <sub>1</sub>	A <sub>2</sub>	A <sub>3</sub>	b <sub>p</sub>	c	D <sup>(1)</sup>	E <sup>(1)</sup>	e	HE	L	L <sub>p</sub>	Q	v	w	y	z <sup>(1)</sup>	θ
mm	2.65	0.30 0.10	2.45 2.25	0.25	0.49 0.36	0.32 0.23	15.6 15.2	7.6 7.4	1.27	10.65 10.00	1.4	1.1 0.4	1.1 1.0	0.25	0.25	0.1	0.9 0.4	8° 0°
inches	0.10	0.012 0.004	0.096 0.089	0.01	0.019 0.014	0.013 0.009	0.61 0.60	0.30 0.29	0.050	0.419 0.394	0.055	0.043 0.016	0.043 0.039	0.01	0.01	0.004	0.035 0.016	

**Note**

1. Plastic or metal protrusions of 0.15 mm maximum per side are not included.

OUTLINE VERSION	REFERENCES				EUROPEAN PROJECTION	ISSUE DATE
	IEC	JEDEC	EIAJ			
SOT137-1	075E05	MS-013				-97-05-22 99-12-27

## Transceivers/registers

74F646A/74F648A

## REVISION HISTORY

Rev	Date	Description
_4	20030204	<b>74F646A/74F648A Product data (9397 750 05151); ECN 853-1124 29306 of 17 December 2002. Supersedes 74F646A/74F648A_3 of 1990Sep25.</b> Modifications: <ul style="list-style-type: none"> <li>• Delete all references to non-A version specifications. The non-A versions of these devices have been discontinued.</li> </ul>
_3	19900925	<b>74F646A/74F648A Product specification (9397 750 05151); ECN 853-1124 00515 of 25 September 1990.</b>

## Data sheet status

Level	Data sheet status <sup>[1]</sup>	Product status <sup>[2] [3]</sup>	Definitions
I	Objective data	Development	This data sheet contains data from the objective specification for product development. Philips Semiconductors reserves the right to change the specification in any manner without notice.
II	Preliminary data	Qualification	This data sheet contains data from the preliminary specification. Supplementary data will be published at a later date. Philips Semiconductors reserves the right to change the specification without notice, in order to improve the design and supply the best possible product.
III	Product data	Production	This data sheet contains data from the product specification. Philips Semiconductors reserves the right to make changes at any time in order to improve the design, manufacturing and supply. Relevant changes will be communicated via a Customer Product/Process Change Notification (CPCN).

[1] Please consult the most recently issued data sheet before initiating or completing a design.

[2] The product status of the device(s) described in this data sheet may have changed since this data sheet was published. The latest information is available on the Internet at URL <http://www.semiconductors.philips.com>.

[3] For data sheets describing multiple type numbers, the highest-level product status determines the data sheet status.

## Definitions

**Short-form specification** — The data in a short-form specification is extracted from a full data sheet with the same type number and title. For detailed information see the relevant data sheet or data handbook.

**Limiting values definition** — Limiting values given are in accordance with the Absolute Maximum Rating System (IEC 60134). Stress above one or more of the limiting values may cause permanent damage to the device. These are stress ratings only and operation of the device at these or at any other conditions above those given in the Characteristics sections of the specification is not implied. Exposure to limiting values for extended periods may affect device reliability.

**Application information** — Applications that are described herein for any of these products are for illustrative purposes only. Philips Semiconductors make no representation or warranty that such applications will be suitable for the specified use without further testing or modification.

## Disclaimers

**Life support** — These products are not designed for use in life support appliances, devices, or systems where malfunction of these products can reasonably be expected to result in personal injury. Philips Semiconductors customers using or selling these products for use in such applications do so at their own risk and agree to fully indemnify Philips Semiconductors for any damages resulting from such application.

**Right to make changes** — Philips Semiconductors reserves the right to make changes in the products—including circuits, standard cells, and/or software—described or contained herein in order to improve design and/or performance. When the product is in full production (status 'Production'), relevant changes will be communicated via a Customer Product/Process Change Notification (CPCN). Philips Semiconductors assumes no responsibility or liability for the use of any of these products, conveys no license or title under any patent, copyright, or mask work right to these products, and makes no representations or warranties that these products are free from patent, copyright, or mask work right infringement, unless otherwise specified.

## Contact information

For additional information please visit  
<http://www.semiconductors.philips.com>. Fax: +31 40 27 24825

© Koninklijke Philips Electronics N.V. 2003  
 All rights reserved. Printed in U.S.A.

Date of release: 02-03

For sales offices addresses send e-mail to:  
[sales.addresses@www.semiconductors.philips.com](mailto:sales.addresses@www.semiconductors.philips.com)

Document order number:

9397 750 11051

*Let's make things better.*



LittleDiode supplies new, hard to find or obsolete electronic components and semiconductors all over the world.

With over two million different components listed you are sure to find the part you need.

Feel free to visit us today at our online store:

[LittleDiode.com](http://LittleDiode.com)

Looking forward to providing you with the best possible service.