

DATA SHEET

74F621

Octal bus transceiver, non-inverting
(open collector)

Product specification

1996 Jan 05

IC15 Data Handbook

Octal bus transceiver, non-inverting (open collector)

74F621

FEATURES

- High-impedance NPN base inputs for reduced loading (20 μ A in High and Low states)
- Octal bidirectional bus interface
- Open collector outputs sink 64mA
- Non-inverting

DESCRIPTION

The 74F621 is an octal transceiver featuring non-inverting open collector bus-compatible outputs in both send and receive directions. The outputs are capable of sinking 64mA, providing very good capacitive drive characteristics.

This octal bus transceiver is designed for asynchronous two-way communication between data buses. The control function implementation allows for maximum flexibility in timing.

The device allows data transmission from the A bus to the B bus or from the B bus to the A bus, depending upon the logic levels at the Enable inputs (\overline{OEBA} and OEAB). The Enable inputs can be used to disable the device so that the buses are effectively isolated.

The dual-enable configuration gives the 74F621 the capability to store data by the simultaneous enabling of \overline{OEBA} and OEAB. Each output reinforces its input in this transceiver configuration. Thus, when both control inputs are enabled and all other data sources to the two sets of the bus lines are at high impedance, both sets of bus lines (16 in all) will remain in their last states.

PIN CONFIGURATION

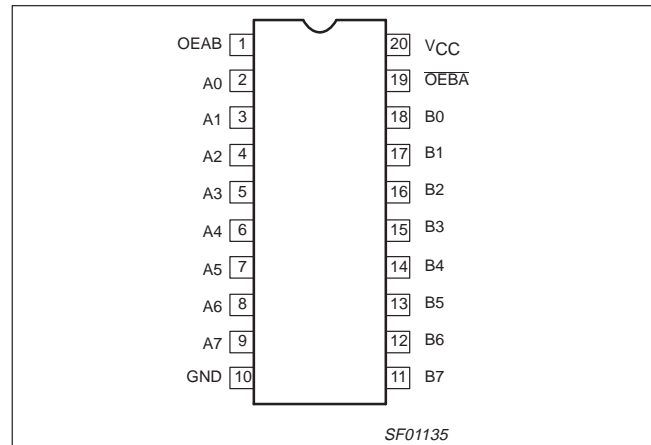

TYPE	TYPICAL PROPAGATION DELAY	TYPICAL SUPPLY CURRENT (TOTAL)
74F621	8.0ns	105mA

ORDERING INFORMATION

DESCRIPTION	COMMERCIAL RANGE $V_{CC} = 5V \pm 10\%$, $T_{amb} = 0^{\circ}C$ to $+70^{\circ}C$	PKG DWG #
20-pin plastic DIP	N74F621N	SOT146-1
20-pin plastic SOL	N74F621D	SOT163-1

INPUT AND OUTPUT LOADING AND FAN-OUT TABLE

PINS	DESCRIPTION	74F(U.L.) HIGH/LOW	LOAD VALUE HIGH/LOW
A0 - A7, B0 - B7	Data inputs	1.0/0.033	20 μ A/20 μ A
\overline{OEBA} , OEAB	Output Enable inputs	1.0/0.033	20 μ A/20 μ A
A0 - A7	Data outputs	OC/40	OC/24mA
B0 - B7	Data outputs	OC/106.7	OC/64mA

NOTE: One (1.0) FAST unit load is defined as: 20 μ A in the High state and 0.6mA in the Low state. OC = Open Collector.

Octal bus transceiver, non-inverting (open collector)

74F621

LOGIC SYMBOL

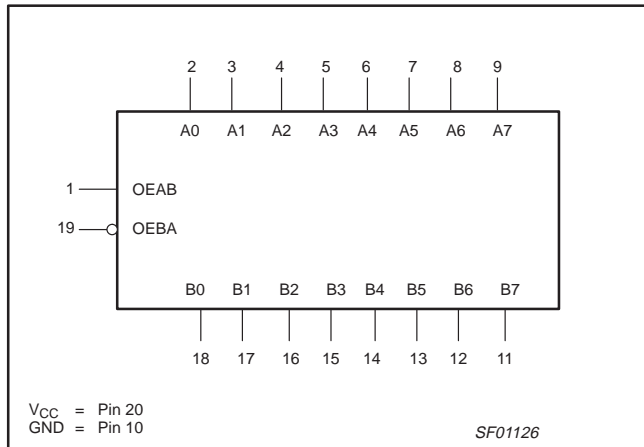

LOGIC SYMBOL (IEEE/IEC)

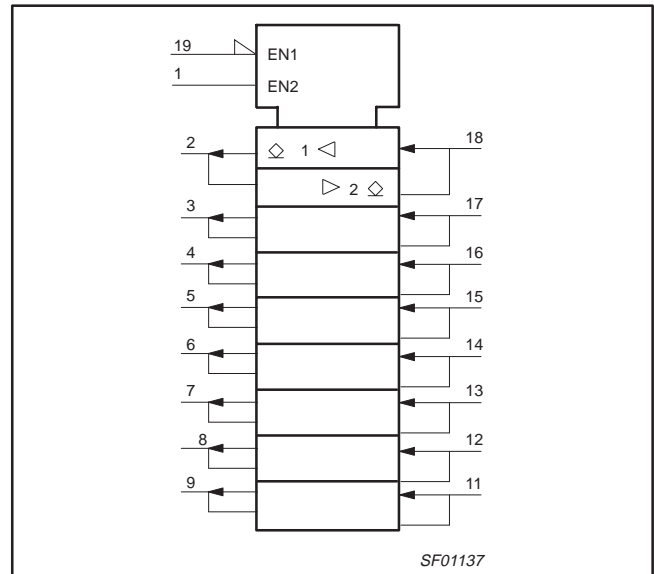

LOGIC DIAGRAM

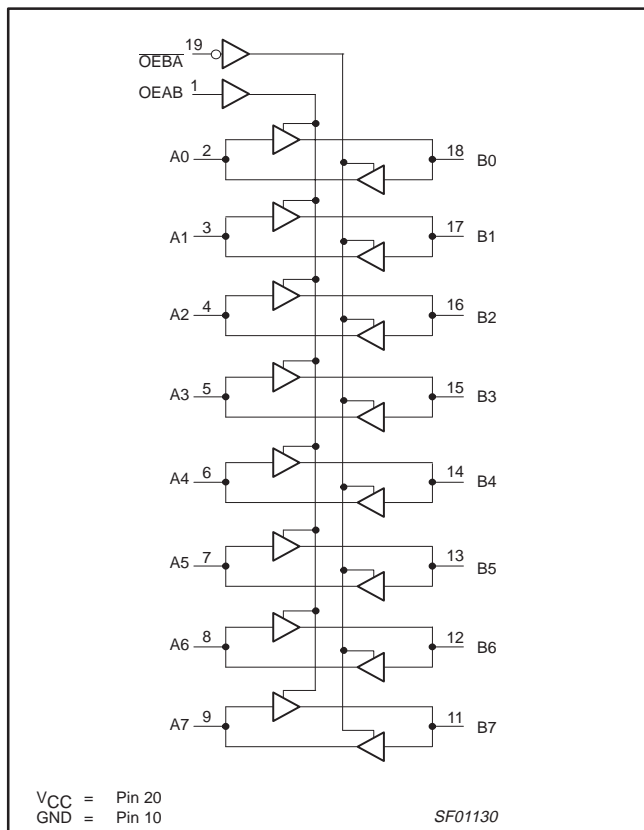

FUNCTION TABLE

INPUTS		OPERATING MODES
OEBA	OEAB	
L	L	B data to A bus
H	H	A data to B bus
H	L	OFF
L	H	B data to A bus
		A data to B bus

H = High voltage level
 L = Low voltage level
 X = Don't care
 OFF= High if pull-up resistor is connected to open collector output

Octal bus transceiver, non-inverting (open collector)

74F621

ABSOLUTE MAXIMUM RATINGS

(Operation beyond the limits set forth in this table may impair the useful life of the device.
Unless otherwise noted these limits are over the operating free-air temperature range.)

SYMBOL	PARAMETER		RATING	UNIT
V_{CC}	Supply voltage		-0.5 to +7.0	V
V_{IN}	Input voltage		-0.5 to +7.0	V
I_{IN}	Input current		-30 to +5	mA
V_{OUT}	Voltage applied to output in High output state		-0.5 to +5.5	V
I_{OUT}	Current applied to output in Low output state	A0–A7	48	mA
		B0–B7	128	mA
T_{amb}	Operating free-air temperature range		0 to +70	°C
T_{stg}	Storage temperature range		-65 to +150	°C

RECOMMENDED OPERATING CONDITIONS

SYMBOL	PARAMETER	LIMITS			UNIT
		MIN	NOM	MAX	
V_{CC}	Supply voltage	4.5	5.0	5.5	V
V_{IH}	High-level input voltage	2.0			V
V_{IL}	Low-level input voltage			0.8	V
I_{IK}	Input clamp current			-18	mA
V_{OH}	High-level output current			4.5	V
I_{OL}	Low-level output current	A0–A7		24	mA
		B0–B7		64	mA
T_{amb}	Operating free-air temperature range	0		70	°C

DC ELECTRICAL CHARACTERISTICS

(Over recommended operating free-air temperature range unless otherwise noted.)

SYMBOL	PARAMETER	TEST CONDITIONS ^{NO TAG}	LIMITS			UNIT	
			MIN	TYP NO TAG	MAX		
I_{OH}	High-level output current	$V_{CC} = \text{MIN}, V_{IL} = \text{MAX}, V_{IH} = \text{MIN}, V_{OH} = \text{MAX}$			250	μA	
V_{OL}	Low-level output voltage	A0–A7	$V_{CC} = \text{MIN}, V_{IL} = \text{MAX}, V_{IH} = \text{MIN}, I_{OL} = 24\text{mA}$	$\pm 10\%V_{CC}$	0.35	0.50	V
				$\pm 5\%V_{CC}$	0.35	0.50	V
		B0–B7	$V_{CC} = \text{MIN}, V_{IL} = \text{MAX}, V_{IH} = \text{MIN}, I_{OL} = 48\text{mA}$	$\pm 10\%V_{CC}$	0.38	0.55	V
				$\pm 5\%V_{CC}$	0.42	0.55	V
V_{IK}	Input clamp voltage	$V_{CC} = \text{MIN}, I_I = I_{IK}$		-0.73	-1.2	V	
I_I	Input current at maximum input voltage	$\overline{OEBA}, OEAB$	$V_{CC} = \text{MAX}, V_I = 7.0\text{V}$		100	μA	
		others	$V_{CC} = 0.0\text{V}, V_I = 5.5\text{V}$		1	mA	
I_{IH}	High-level input current	$V_{CC} = \text{MAX}, V_I = 2.7\text{V}$			20	μA	
I_{IL}	Low-level input current	$V_{CC} = \text{MAX}, V_I = 0.5\text{V}$			-20	μA	
I_{CC}	Supply current (total)	I_{CCH}	$V_{CC} = \text{MAX}$	$\overline{OEBA} = OEAB = A0-A7 = 4.5\text{V}$	105	140	mA
		I_{CCL}		$\overline{OEBA} = OEAB = 4.5\text{V}, A0-A7 = \text{GND}$	105	140	mA

NOTES:

- For conditions shown as MIN or MAX, use the appropriate value specified under recommended operating conditions for the applicable type.
- All typical values are at $V_{CC} = 5\text{V}, T_{amb} = 25^\circ\text{C}$.

Octal bus transceiver, non-inverting (open collector)

74F621

AC ELECTRICAL CHARACTERISTICS

SYMBOL	PARAMETER	TEST CONDITION	LIMITS					UNIT
			V _{CC} = +5V T _{amb} = +25°C C _L = 50pF, R _L = 500Ω			V _{CC} = +5V ± 10% T _{amb} = 0°C to +70°C C _L = 50pF, R _L = 500Ω		
			MIN	TYP	MAX	MIN	MAX	
t _{PLH} t _{PHL}	Propagation delay An to Bn	Waveform 1	6.0 4.0	9.5 6.0	12.0 8.0	5.5 3.5	13.0 8.5	ns
t _{PLH} t _{PHL}	Propagation delay Bn to An	Waveform 1	6.0 3.5	9.0 5.5	12.0 7.5	5.5 3.0	12.5 8.0	ns
t _{PLH} t _{PHL}	Propagation delay OEBA to An	Waveform 2	6.0 3.5	10.0 6.5	13.5 10.5	5.5 3.0	14.0 11.0	ns
t _{PLH} t _{PHL}	Propagation delay OEAB to Bn	Waveform 3	7.0 3.5	12.0 6.5	15.0 9.5	6.0 3.0	17.0 10.0	ns

AC WAVEFORMS

For all waveforms, V_M = 1.5V.

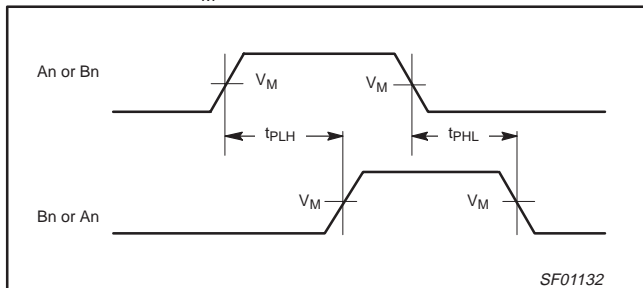

Waveform 1. For Non-Inverting Outputs

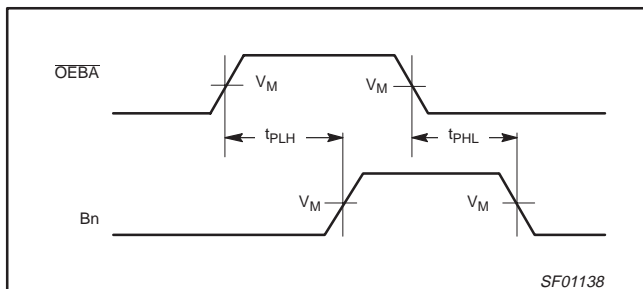

Waveform 2. Propagation Delay, OEBA to An

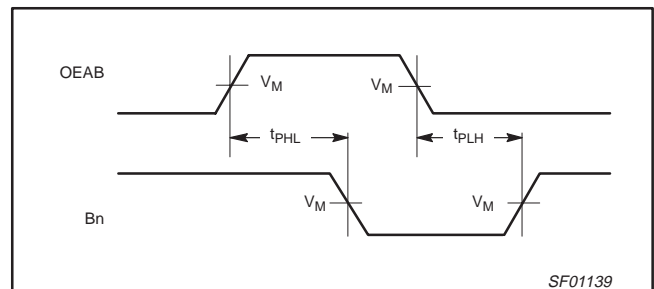

Waveform 3. Propagation Delay, OEAB to Bn

Octal bus transceiver, non-inverting (open collector)

74F621

TYPICAL PROPAGATION DELAYS VERSUS LOAD FOR OPEN COLLECTOR OUTPUTS

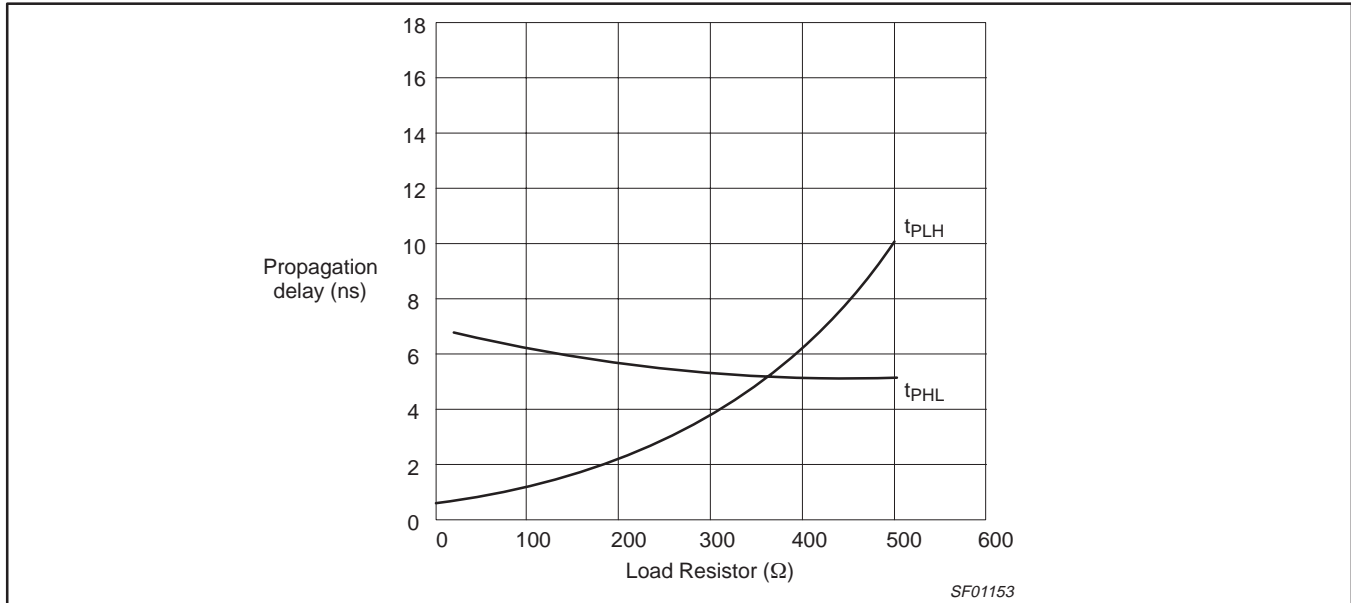

NOTE:

When using open-collector parts, the value of the pull-up resistor greatly affects the value of the t_{PLH}. For example, changing the pull-up resistor value from 500Ω to 100Ω will improve the t_{PLH} up to 50% with only slight increase in the t_{PHL}. However, if the pull-up resistor is changed, the user must take certain that the total I_{OL} current through the resistor and the total I_{IL}'s of the receivers do not exceed the I_{OL} maximum specification.

TEST CIRCUIT AND WAVEFORMS

Test Circuit for Open Collector Outputs

DEFINITIONS:
 R_L = Load resistor; see AC electrical characteristics for value.
 C_L = Load capacitance includes jig and probe capacitance; see AC electrical characteristics for value.
 R_T = Termination resistance should be equal to Z_{OUT} of pulse generators.

Input Pulse Definition

family	INPUT PULSE REQUIREMENTS					
	amplitude	V _M	rep. rate	t _w	t _{TLH}	t _{THL}
74F	3.0V	1.5V	1MHz	500ns	2.5ns	2.5ns

SF00027

Octal bus transceiver, non-inverting (open collector)

74F621

DIP20: plastic dual in-line package; 20 leads (300 mil)

SOT146-1

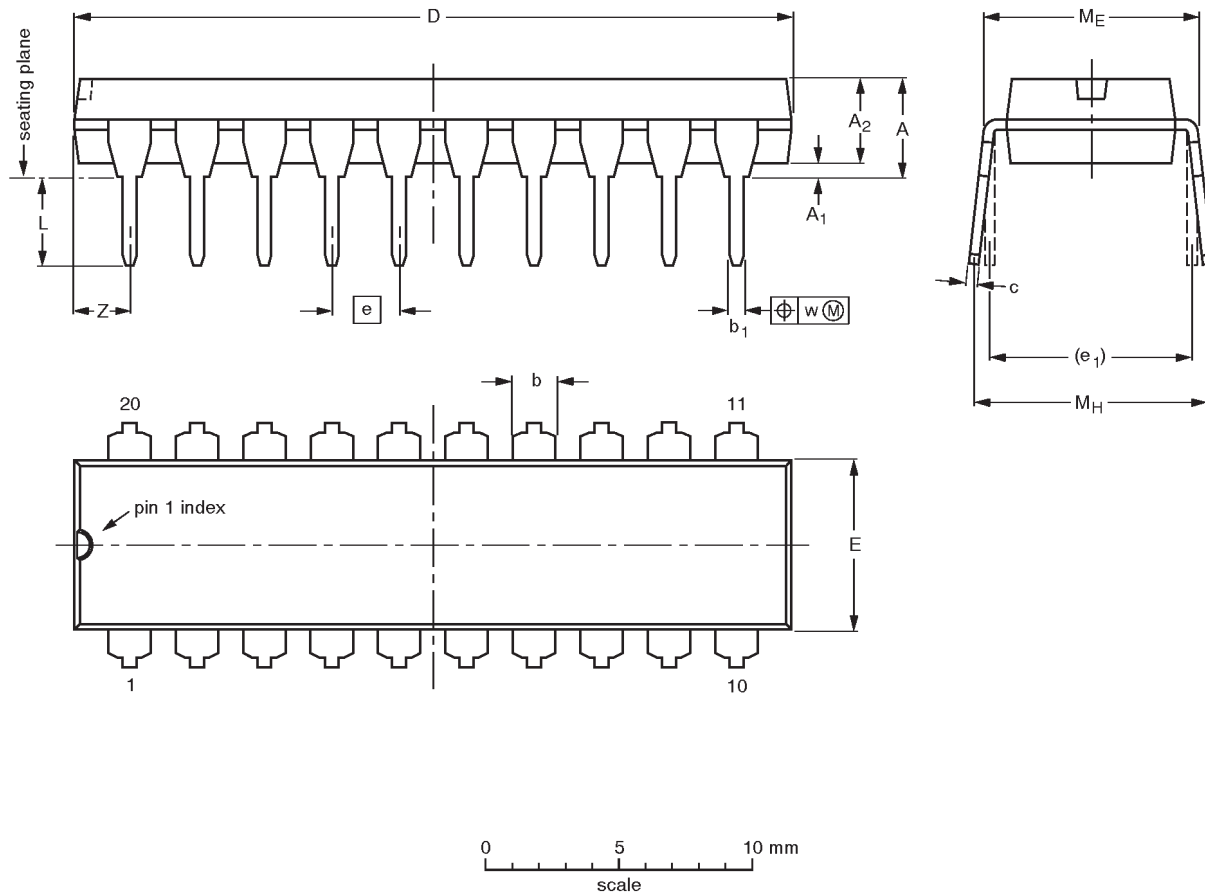

DIMENSIONS (inch dimensions are derived from the original mm dimensions)

UNIT	A max.	A ₁ min.	A ₂ max.	b	b ₁	c	D ⁽¹⁾	E ⁽¹⁾	e	e ₁	L	M _E	M _H	w	Z ⁽¹⁾ max.
mm	4.2	0.51	3.2	1.73 1.30	0.53 0.38	0.36 0.23	26.92 26.54	6.40 6.22	2.54	7.62	3.60 3.05	8.25 7.80	10.0 8.3	0.254	2.0
inches	0.17	0.020	0.13	0.068 0.051	0.021 0.015	0.014 0.009	1.060 1.045	0.25 0.24	0.10	0.30	0.14 0.12	0.32 0.31	0.39 0.33	0.01	0.078

Note

1. Plastic or metal protrusions of 0.25 mm maximum per side are not included.

OUTLINE VERSION	REFERENCES				EUROPEAN PROJECTION	ISSUE DATE
	IEC	JEDEC	EIAJ			
SOT146-1			SC603			92-11-17 95-05-24

Octal bus transceiver, non-inverting (open collector)

74F621

SO20: plastic small outline package; 20 leads; body width 7.5 mm

SOT163-1

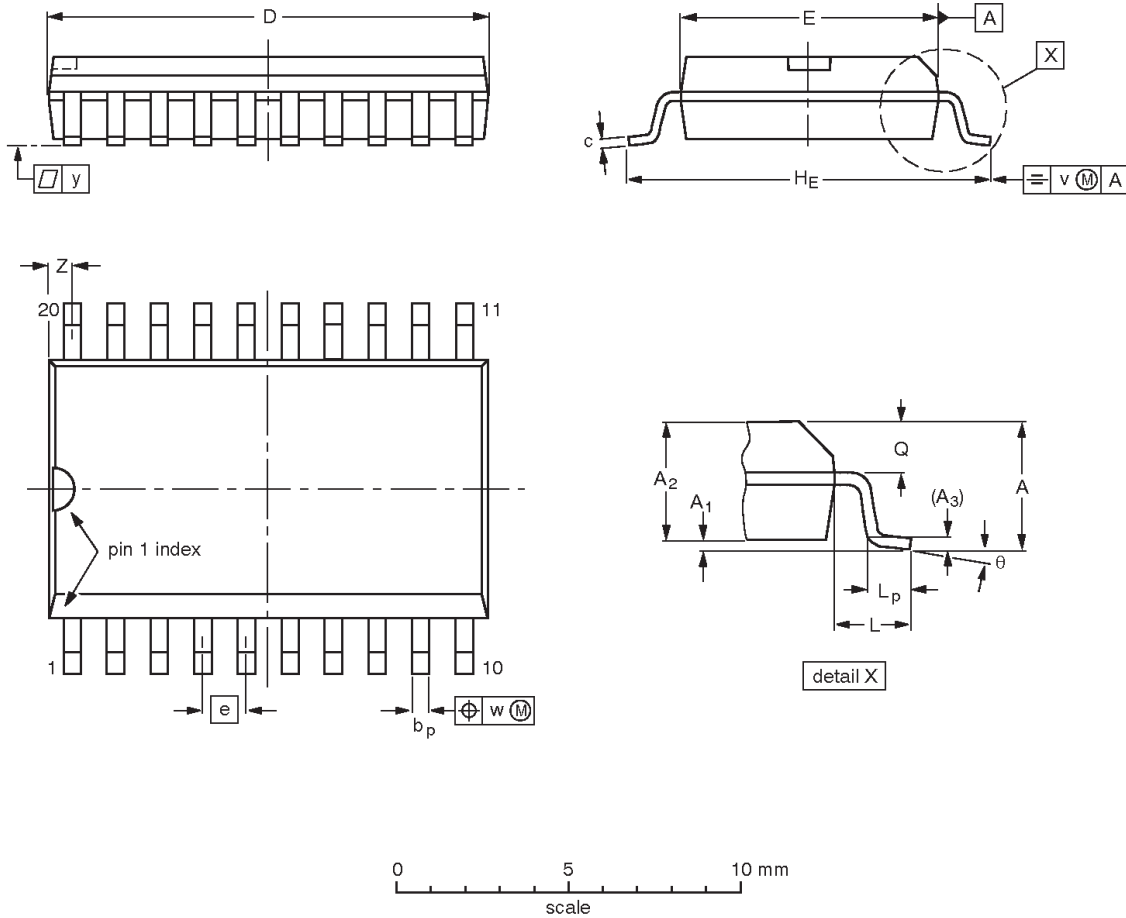

DIMENSIONS (inch dimensions are derived from the original mm dimensions)

UNIT	A max.	A ₁	A ₂	A ₃	b _p	c	D ⁽¹⁾	E ⁽¹⁾	e	H _E	L	L _p	Q	v	w	y	Z ⁽¹⁾	θ
mm	2.65	0.30 0.10	2.45 2.25	0.25	0.49 0.36	0.32 0.23	13.0 12.6	7.6 7.4	1.27	10.65 10.00	1.4	1.1 0.4	1.1 1.0	0.25	0.25	0.1	0.9 0.4	8° 0°
inches	0.10	0.012 0.004	0.096 0.089	0.01	0.019 0.014	0.013 0.009	0.51 0.49	0.30 0.29	0.050	0.419 0.394	0.055	0.043 0.016	0.043 0.039	0.01	0.01	0.004	0.035 0.016	

Note

1. Plastic or metal protrusions of 0.15 mm maximum per side are not included.

OUTLINE VERSION	REFERENCES				EUROPEAN PROJECTION	ISSUE DATE
	IEC	JEDEC	EIAJ			
SOT163-1	075E04	MS-013AC				95-01-24 97-05-22

Octal bus transceiver, non-inverting (open collector)

74F621

NOTES

Octal bus transceiver, non-inverting (open collector)

74F621

DEFINITIONS

Data Sheet Identification	Product Status	Definition
<i>Objective Specification</i>	Formative or in Design	This data sheet contains the design target or goal specifications for product development. Specifications may change in any manner without notice.
<i>Preliminary Specification</i>	Preproduction Product	This data sheet contains preliminary data, and supplementary data will be published at a later date. Philips Semiconductors reserves the right to make changes at any time without notice in order to improve design and supply the best possible product.
<i>Product Specification</i>	Full Production	This data sheet contains Final Specifications. Philips Semiconductors reserves the right to make changes at any time without notice, in order to improve design and supply the best possible product.

Philips Semiconductors and Philips Electronics North America Corporation reserve the right to make changes, without notice, in the products, including circuits, standard cells, and/or software, described or contained herein in order to improve design and/or performance. Philips Semiconductors assumes no responsibility or liability for the use of any of these products, conveys no license or title under any patent, copyright, or mask work right to these products, and makes no representations or warranties that these products are free from patent, copyright, or mask work right infringement, unless otherwise specified. Applications that are described herein for any of these products are for illustrative purposes only. Philips Semiconductors makes no representation or warranty that such applications will be suitable for the specified use without further testing or modification.

LIFE SUPPORT APPLICATIONS

Philips Semiconductors and Philips Electronics North America Corporation Products are not designed for use in life support appliances, devices, or systems where malfunction of a Philips Semiconductors and Philips Electronics North America Corporation Product can reasonably be expected to result in a personal injury. Philips Semiconductors and Philips Electronics North America Corporation customers using or selling Philips Semiconductors and Philips Electronics North America Corporation Products for use in such applications do so at their own risk and agree to fully indemnify Philips Semiconductors and Philips Electronics North America Corporation for any damages resulting from such improper use or sale.

Philips Semiconductors
811 East Arques Avenue
P.O. Box 3409
Sunnyvale, California 94088-3409
Telephone 800-234-7381

Philips Semiconductors and Philips Electronics North America Corporation register eligible circuits under the Semiconductor Chip Protection Act.
 © Copyright Philips Electronics North America Corporation 1996
 All rights reserved. Printed in U.S.A.

(print code)

Date of release: July 1994

Document order number:

9397-750-05147



LittleDiode supplies new, hard to find or obsolete electronic components and semiconductors all over the world.

With over two million different components listed you are sure to find the part you need.

Feel free to visit us today at our online store:

LittleDiode.com

Looking forward to providing you with the best possible service.