



November 1990

54F/74F579 8-Bit Bidirectional Binary Counter with TRI-STATE Outputs

54F/74F579 8-Bit Bidirectional Binary Counter with TRI-STATE® Outputs

General Description

The 'F579 is a fully synchronous 8-stage up/down counter with multiplexed TRI-STATE I/O ports for bus-oriented applications. It features a preset capability for programmable operation, carry lookahead for easy cascading and a U/ \bar{D} input to control the direction of counting. All state changes, whether in counting or parallel loading, are initiated by the rising edge of the clock.

Features

- Multiplexed TRI-STATE I/O ports
- Built-in lookahead carry capability
- Count frequency 100 MHz typical
- Supply current 75 mA typical
- Guaranteed 4000V minimum ESD protection

Logic Symbol

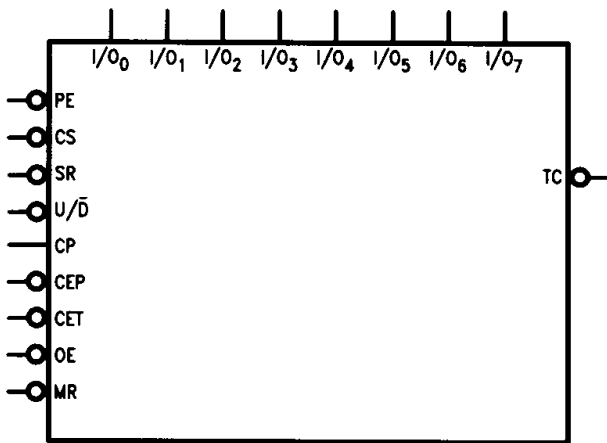

TL/F/9568-1

Connection Diagrams

Pin Assignment
for DIP, SOIC and Flatpak

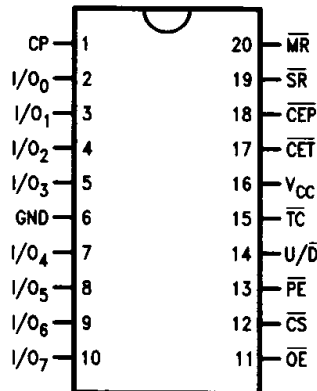

TL/F/9568-2

FAST® and TRI-STATE® are registered trademarks of National Semiconductor Corporation.

Logic Diagram

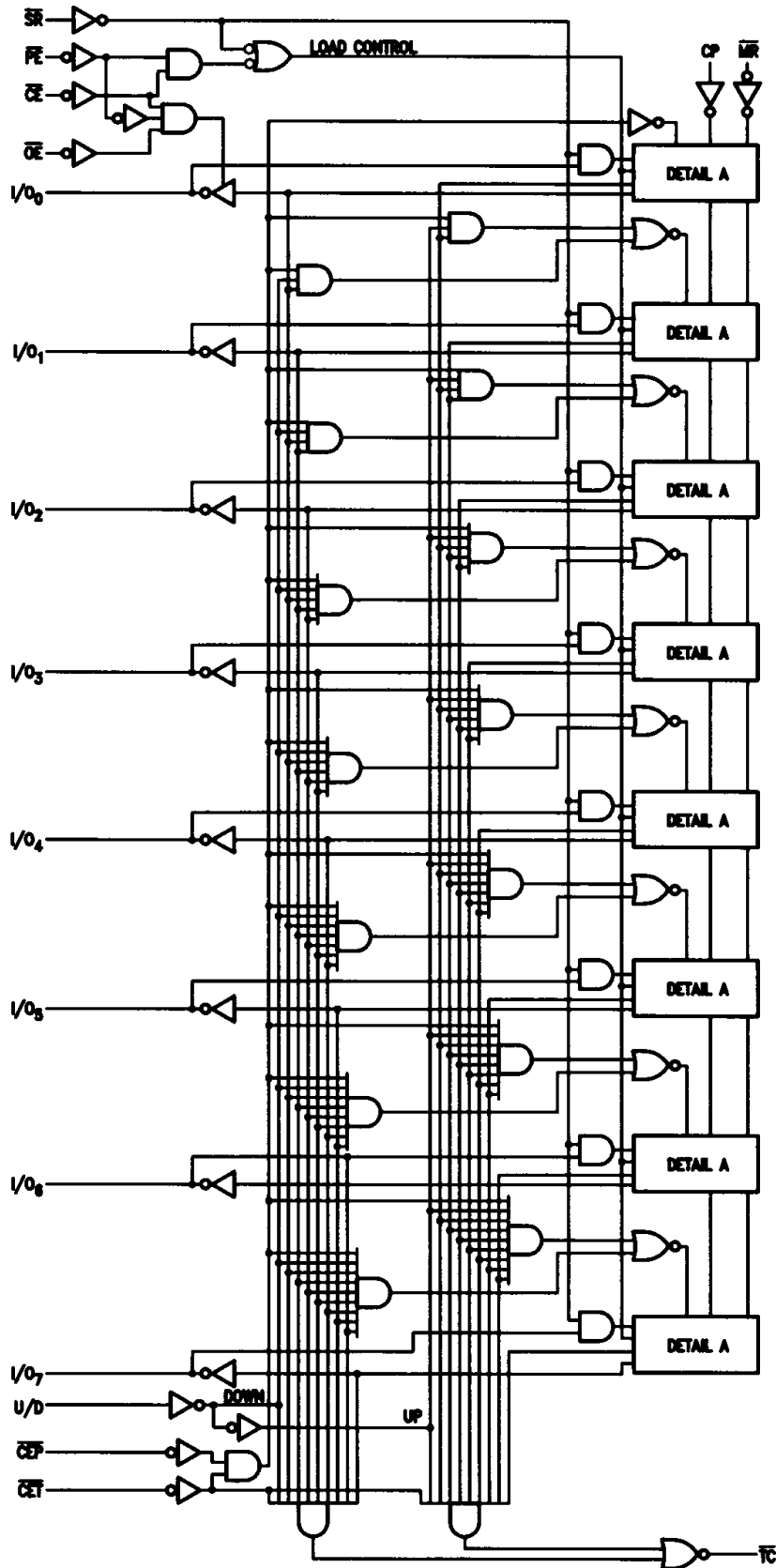

TL/F/9568-5

Please note that this diagram is provided only for the understanding of logic operations and should not be used to estimate propagation delays.

Logic Diagram (Continued)

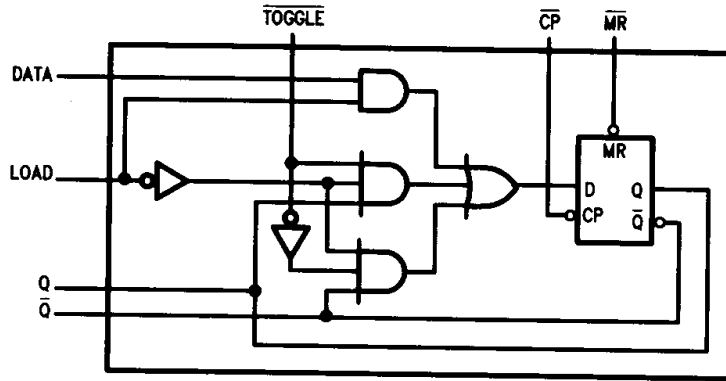

V_{CC} = Pin 16
 GND = Pin 6
 () = Pin Numbers

Detail A

TL/F/9568-6

Unit Loading/Fan Out

Pin Names	Description	54F/74F	
		U.L. HIGH/LOW	Input I _{IH} /I _{IL} Output I _{OH} /I _{OL}
I/O ₀ -I/O ₇	Data Inputs or TRI-STATE Outputs	3.5/0.333 75/15 (12.5)	70 μA/ -0.2 mA -3 mA/24 mA (20 mA)
PE	Parallel Enable Input (Active LOW)	0.25/0.333	5 μA/ -0.2 mA
U/D	Up-Down Count Control Input	0.25/0.333	5 μA/ -0.2 mA
MR	Master Reset Input (Active LOW)	0.25/0.333	5 μA/ -0.2 mA
SR	Synchronous Reset Input (Active LOW)	0.25/0.333	5 μA/ -0.2 mA
CEP	Count Enable Parallel Input (Active LOW)	0.25/0.333	5 μA/ -0.2 mA
CET	Count Enable Trickle Input (Active LOW)	0.25/0.333	5 μA/ -0.2 mA
CS	Chip Select Input Active (Active LOW)	0.25/0.333	5 μA/ -0.2 mA
OE	Output Enable Input (Active LOW)	0.25/0.333	5 μA/ -0.2 mA
CP	Clock Pulse Input (Active Rising Edge)	0.25/0.333	5 μA/ -0.2 mA
TC	Terminal Count Output (Active LOW)	25/12.5	-1 mA/5 mA

Function Table

MR	SR	CS	PE	CEP	CET	U/D	OE	CP	Function
X	X	H	X	X	X	X	X	X	I/O _a to I/O _h in High Z (PE Disabled)
X	X	L	H	X	X	X	H	X	I/O _a to I/O _h in High Z
X	X	L	H	X	X	X	L	X	Flip-Flop Outputs Appear on I/O Lines
L	X	X	X	X	X	X	X	X	Asynchronous Reset for all Flip-Flops
H	L	X	X	X	X	X	X	⎯	Synchronous Reset for all Flip-Flops
H	H	L	L	X	X	X	X	⎯	Parallel Load all Flip-Flops
H	H	(Not LL)		H	X	X	X	⎯	Hold
H	H	(Not LL)		X	H	X	X	⎯	Hold (TC Held HIGH)
H	H	(Not LL)		L	L	H	X	⎯	Count Up
H	H	(Not LL)		L	L	L	X	⎯	Count Down

H = HIGH Voltage Level

L = LOW Voltage Level

X = Immaterial

⎯ = LOW to HIGH Clock Transition

Not LL = CS and PE should never both be LOW voltage level at the same time.

Absolute Maximum Ratings (Note 1)

If Military/Aerospace specified devices are required, please contact the National Semiconductor Sales Office/Distributors for availability and specifications.

Storage Temperature	-65°C to +150°C
Ambient Temperature under Bias	-55°C to +125°C
Junction Temperature under Bias	-55°C to +175°C
V _{CC} Pin Potential to Ground Pin	-0.5V to +7.0V
Input Voltage (Note 2)	-0.5V to +7.0V
Input Current (Note 2)	-30 mA to +5.0 mA
Voltage Applied to Output in HIGH State (with V _{CC} = 0V)	
Standard Output	-0.5V to V _{CC}
TRI-STATE Output	-0.5V to +5.5V
Current Applied to Output in LOW State (Max)	twice the rated I _{OL} (mA)
ESD Last Passing Voltage (Min)	4000V

Note 1: Absolute maximum ratings are values beyond which the device may be damaged or have its useful life impaired. Functional operation under these conditions is not implied.

Note 2: Either voltage limit or current limit is sufficient to protect inputs.

Recommended Operating Conditions

Free Air Ambient Temperature	
Military	-55°C to +125°C
Commercial	0°C to +70°C
Supply Voltage	
Military	+4.5V to +5.5V
Commercial	+4.5V to +5.5V

DC Electrical Characteristics

Symbol	Parameter	54F/74F			Units	V _{CC}	Conditions
		Min	Typ	Max			
V _{IH}	Input HIGH Voltage	2.0			V		Recognized as a HIGH Signal
V _{IL}	Input LOW Voltage			0.8	V		Recognized as a LOW Signal
V _{CD}	Input Clamp Diode Voltage			-1.2	V	Min	I _{IN} = -18 mA
V _{OH}	Output HIGH Voltage	Mil 10% V _{CC} 5% V _{CC}	2.4 2.4 2.7		V	Min	I _{OH} = -3 mA
V _{OL}	Output LOW Voltage	Mil 10% V _{CC} 5% V _{CC}		0.5 0.5 0.5	V	Min	I _{OL} = 24 mA (TC, I/O _n) I _{OL} = 20 mA (TC), I _{OL} = 24 mA (I/O _n) I _{OL} = 20 mA (TC), I _{OL} = 24 mA (I/O _n)
I _{IH}	Input HIGH Current	54F 74F		20.0 5.0	μA	Max	V _{IN} = 2.7V (Non-I/O Pins)
I _{BVI}	Input HIGH Current Breakdown Test	54F 74F		100 7.0	μA	Max	V _{IN} = 7.0V (Non-I/O Pins)
I _{BVIT}	Input HIGH Current Breakdown (I/O)	54F 74F		1.0 0.5	mA	Max	V _{IN} = 5.5V (I/O _n)
I _{CEX}	Output HIGH Leakage Current	54F 74F		250 50	μA	Max	V _{OUT} = V _{CC}
V _{ID}	Input Leakage Test	74F	4.75		V	0.0	I _{ID} = 1.9 μA All Other Pins Grounded
I _{OD}	Output Leakage Circuit Control	74F		3.75	μA	0.0	V _{IOD} = 150 mV All Other Pins Grounded
I _{ZZ}	Bus Drainage Test			500	μA	0.0	V _{OUT} = 5.25V
I _{IL}	Input LOW Current			-0.2	mA	Max	V _{IN} = 0.5V (Non-I/O Pins)
I _{IH} & I _{OZH}	Output Leakage Current			70	μA	Max	V _{OUT} = 2.7V (I/O _n)
I _{IL} & I _{OZL}	Output Leakage Current			-200	μA	Max	V _{OUT} = 0.5V (I/O _n)
I _{OS}	Output Short-Circuit Current		-60	-150	mA	Max	V _{OUT} = 0V
I _{CCH}	Power Supply Current		70	110	mA	Max	V _O = HIGH
I _{CCL}	Power Supply Current		85	120	mA	Max	V _O = LOW
I _{CCZ}	Power Supply Current		85	125	mA	Max	V _O = HIGH Z

AC Electrical Characteristics

Symbol	Parameter	74F			54F		74F		Units
		T _A = +25°C V _{CC} = +5.0V C _L = 50 pF			T _A , V _{CC} = Mil C _L = 50 pF		T _A , V _{CC} = Comm C _L = 50 pF		
		Min	Typ	Max	Min	Max	Min	Max	
f _{max}	Maximum Clock Frequency	90	105			80			
t _{PLH} t _{PHL}	Propagation Delay CP to I/O _n	3.0 5.0	5.0 8.0	7.5 11.5			3.0 5.0	8.0 11.5	ns
t _{PLH} t _{PHL}	Propagation Delay CP to \overline{TC}	5.0 5.0	7.5 9.0	11.5 11.5			5.0 5.0	12.0 12.0	ns
t _{PLH} t _{PHL}	Propagation Delay U/ \overline{D} to \overline{TC}	4.5 4.5	7.0 8.0	9.0 9.5			4.5 4.5	10.0 10.0	ns
t _{PLH} t _{PHL}	Propagation Delay \overline{CEP} or \overline{CET} to \overline{TC}	2.5 3.5	3.8 6.0	6.0 8.0			2.5 3.5	6.5 8.5	ns
t _{PHL}	Propagation Delay \overline{MR} to I/O _n	5.0	7.5	10.0			5.0	10.0	ns
t _{PHL}	Propagation Delay \overline{MR} to TC	6.5	10.0	13.0			6.5	13.5	ns
t _{PZH} t _{PZL}	Output Enable Time \overline{CS} or \overline{PE} to I/O	3.0 5.5	5.0 8.0	8.5 10.5			3.0 5.5	9.0 11.5	ns
t _{PHZ} t _{PLZ}	Output Disable Time \overline{CS} or \overline{PE} to I/O	2.0 2.0	5.0 4.5	8.5 8.0			2.0 2.0	9.0 8.5	ns
t _{PZH} t _{PZL}	Output Enable Time \overline{OE} to I/O _n	3.0 5.0	5.0 8.0	8.0 11.0			3.0 5.0	8.5 12.0	ns
t _{PHZ} t _{PLZ}	Output Disable Time \overline{OE} to I/O _n	2.0 2.0	4.0 4.0	6.5 6.0			2.0 2.0	6.5 6.5	ns

AC Operating Requirements

Symbol	Parameter	74F			54F		74F	
		T _A = +25°C V _{CC} = +5.0V			T _A , V _{CC} = Mil		T _A , V _{CC} = Comm	
		Min	Typ	Max	Min	Max	Min	Max
t _s (H)	Setup Time	4.0					4.0	
t _s (L)	I/O _n to CP	4.0					4.0	
t _h (H)	Hold Time	0.0					0.0	
t _h (L)	I/O _n to CP	0.0					0.0	
t _s (H)	Setup Time	9.5					9.5	
t _s (L)	\overline{PE} , \overline{CS} or \overline{SR} to CP	9.5					9.5	
t _h (H)	Hold Time	0.0					0.0	
t _h (L)	\overline{PE} , \overline{CS} or \overline{SR} to CP	0.0					0.0	
t _s (H)	Setup Time	6.5					6.5	
t _s (L)	$\overline{CE\overline{T}}$ or $\overline{CE\overline{P}}$ to CP	9.5					9.5	
t _h (H)	Hold Time	0.0					0.0	
t _h (L)	$\overline{CE\overline{T}}$ or $\overline{CE\overline{P}}$ to CP	0.0					0.0	
t _s (H)	Setup Time	9.0					9.5	
t _s (L)	U/ \overline{D} to CP	9.0					9.5	
t _h (H)	Hold Time	0.0					0.0	
t _h (L)	U/ \overline{D} to CP	0.0					0.0	
t _w (H)	Clock Pulse Width	4.5					4.5	
t _w (L)	High or Low	4.5					4.5	
t _w (L)	\overline{MR} Pulse Width	3.0					3.0	
t _{rec}	Recovery Time \overline{MR} to CP	4.0					4.0	

Ordering Information

The device number is used to form part of a simplified purchasing code where a package type and temperature range are defined as follows:

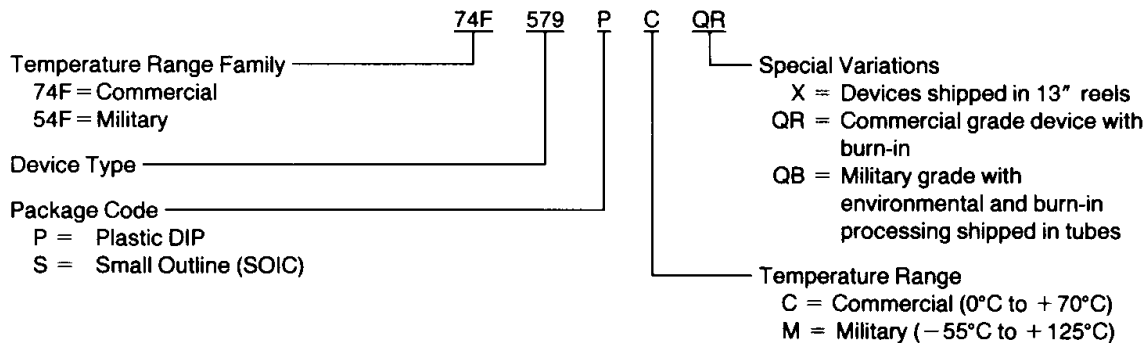

Physical Dimensions inches (millimeters)

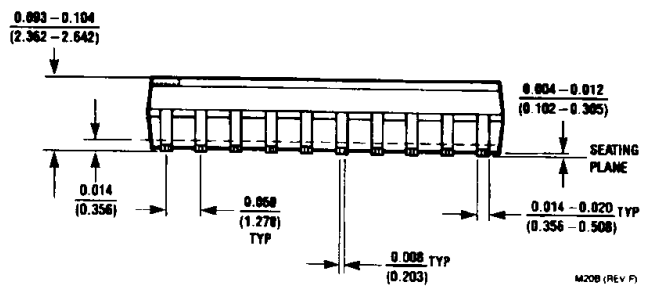
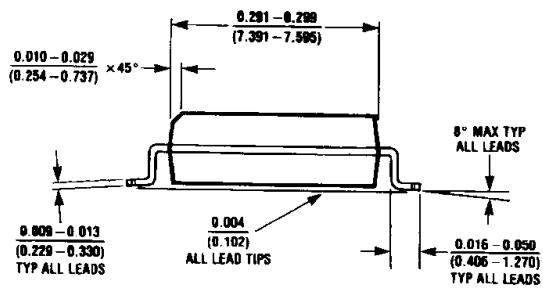
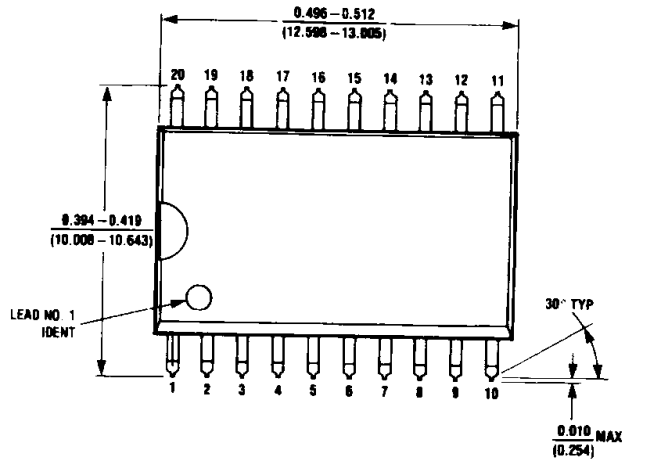

**20-Lead Small Outline Package - JEDEC (S)
NS Package Number M20B**

M20B (REV F)

Physical Dimensions inches (millimeters) (Continued)

Lit # 114651

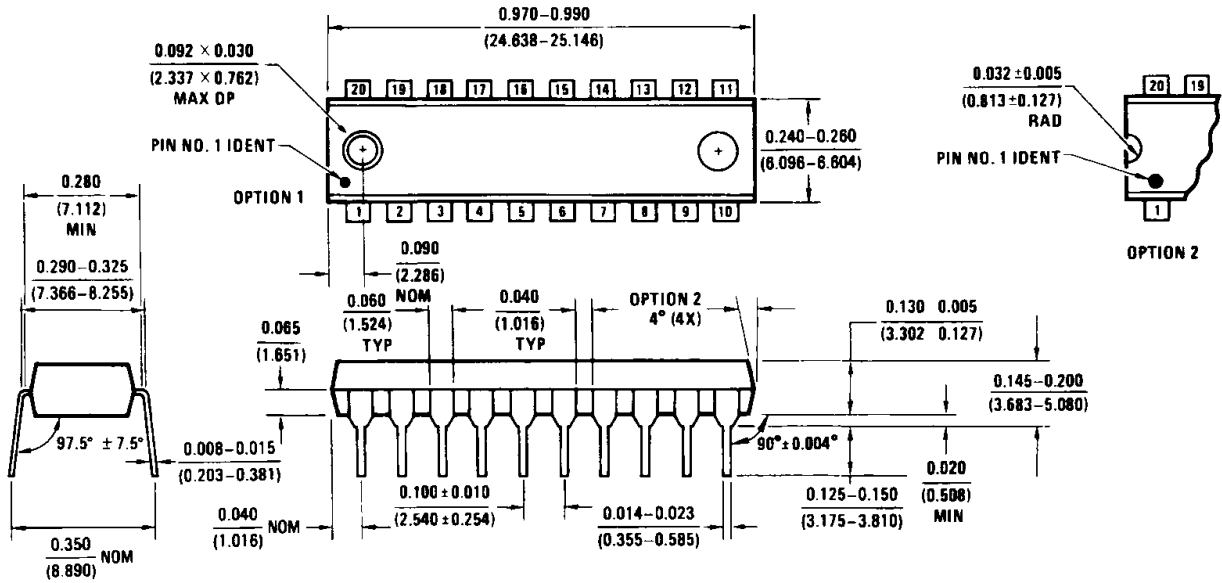

**20-Lead Plastic Dual In-Line Package (P)
NS Package Number N20B**

N20B (REV A)

LIFE SUPPORT POLICY

NATIONAL'S PRODUCTS ARE NOT AUTHORIZED FOR USE AS CRITICAL COMPONENTS IN LIFE SUPPORT DEVICES OR SYSTEMS WITHOUT THE EXPRESS WRITTEN APPROVAL OF THE PRESIDENT OF NATIONAL SEMICONDUCTOR CORPORATION. As used herein:

1. Life support devices or systems are devices or systems which, (a) are intended for surgical implant into the body, or (b) support or sustain life, and whose failure to perform, when properly used in accordance with instructions for use provided in the labeling, can be reasonably expected to result in a significant injury to the user.
2. A critical component is any component of a life support device or system whose failure to perform can be reasonably expected to cause the failure of the life support device or system, or to affect its safety or effectiveness.

022508 ✓



National Semiconductor Corporation
2900 Semiconductor Drive
P.O. Box 58090
Santa Clara, CA 95052-8090
Tel: (408) 721-5000
TWX: (910) 339-9240

National Semiconductor GmbH
Industriestrasse 10
D-8080 Furstenfeldbruck
West Germany
Tel: (0-81-41) 103-0
Telex: 527-649
Fax: (08141) 103554

National Semiconductor Japan Ltd.
Sanso Bldg. 5F
4-15 Nishi Shinjuku
Shinjuku-Ku,
Tokyo 160, Japan
Tel: 3-299-7001
FAX: 3-299-7000

National Semiconductor Hong Kong Ltd.
Suite 513, 5th Floor
Chinachem Golden Plaza,
77 Mody Road, Tsimshatsui East,
Kowloon, Hong Kong
Tel: 3-7231290
Telex: 52996 NSSEA HX
Fax: 3-3112536

National Semicondutores Do Brasil Ltda.
Av. Brig. Faria Lima, 1383
6.0 Andor-Corj. 62
01451 Sao Paulo, SP, Brasil
Tel: (55/11) 212-5066
Fax: (55/11) 211-1181 NSBR BR

National Semiconductor (Australia) PTY, Ltd.
1st Floor, 441 St. Kilda Rd.
Melbourne, 3004
Victoria, Australia
Tel: (03) 267-5000
Fax: 61-3-2677458

This datasheet has been downloaded from:

www.DatasheetCatalog.com

Datasheets for electronic components.

National Semiconductor was acquired by Texas Instruments.

http://www.ti.com/corp/docs/investor_relations/pr_09_23_2011_national_semiconductor.html

This file is the datasheet for the following electronic components:

74F579PCQR - <http://www.ti.com/product/74f579pcqr?HQS=TI-null-null-dscatalog-df-pf-null-wwe>



LittleDiode supplies new, hard to find or obsolete electronic components and semiconductors all over the world.

With over two million different components listed you are sure to find the part you need.

Feel free to visit us today at our online store:

LittleDiode.com

Looking forward to providing you with the best possible service.