

# DATA SHEET

**74F377A**

Octal D-type flip-flop with enable

Product specification

1996 Mar 12

IC15 Data Handbook

# Octal D-type flip-flop with enable

# 74F377A

## FEATURES

- High impedance inputs for reduced loading (20µA in Low and High states)
- Ideal for addressable register applications
- Enable for address and data synchronization applications
- Eight edge-triggered D-type flip-flops
- Buffered common clock
- See 'F273A for Master Reset version
- See 'F373 for transparent latch version
- See 'F374 for 3-State version

## DESCRIPTION

The 74F377A has 8 edge-triggered D-type flip-flops with individual D inputs and Q outputs. The common buffered clock (CP) input loads all flip-flops simultaneously when the Enable ( $\bar{E}$ ) input is Low.

The register is fully edge triggered. The state of each D input, one set-up time before the Low-to-High clock transition, is transferred to the corresponding flip-flop's Q output.

The  $\bar{E}$  input must be stable one setup time prior to the Low-to-High clock transition for predictable operation.

TYPE	TYPICAL $f_{MAX}$	TYPICAL SUPPLY CURRENT (TOTAL)
74F377A	165MHz	29mA

## ORDERING INFORMATION

PACKAGES	COMMERCIAL RANGE $V_{CC} = 5V \pm 10\%$ ; $T_{amb} = 0^\circ C$ to $+70^\circ C$	PKG. DWG. #
20-pin plastic DIP	N74F377AN	SOT146-1
20-pin plastic SOL	N74F377AD	SOT163-1

## INPUT AND OUTPUT LOADING AND FAN-OUT TABLE

PINS	DESCRIPTION	74F(U.L.) HIGH/LOW	LOAD VALUE HIGH/LOW
D0 – D7	Data inputs	1.0/0.033	20µA/20µA
CP	Clock pulse input (active rising edge)	1.0/0.033	20µA/20µA
$\bar{E}$	Enable input (active-Low)	1.0/0.033	20µA/20µA
Q0 – Q7	Data outputs	50/33	1.0mA/20mA

## PIN CONFIGURATION

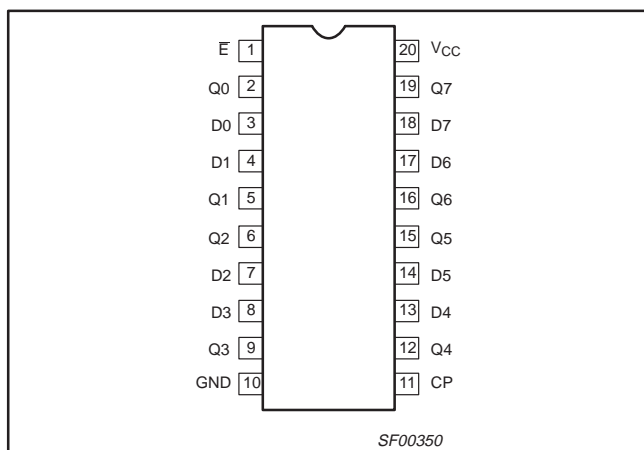

## LOGIC SYMBOL

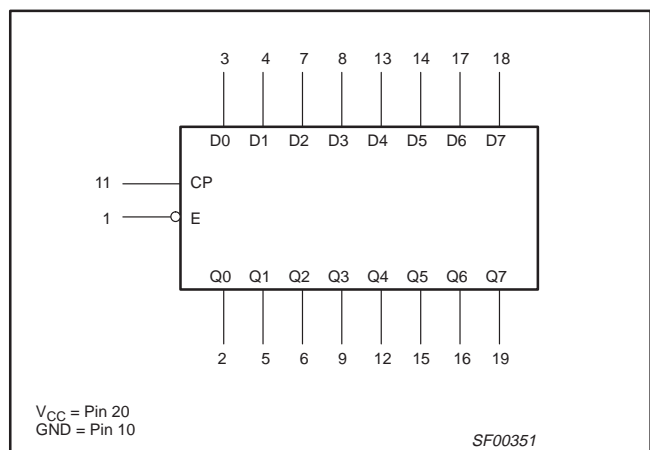

# Octal D-type flip-flop with enable

## 74F377A

### LOGIC SYMBOL (IEEE/IEC)

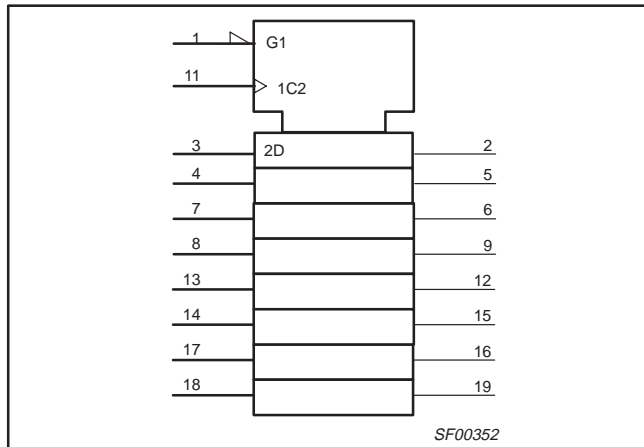

### FUNCTION TABLE

INPUTS			OUTPUTS	OPERATING MODE
$\bar{E}$	CP	Dn	Qn	
l	↑	h	H	Load "1"
l	↑	l	L	Load "0"
h H	↑ X	X X	no change no change	Hold (do nothing)

H = High voltage level  
 h = High voltage level one set-up time prior to the Low-to-High clock transition  
 L = Low voltage level  
 l = Low voltage level one set-up time prior to the Low-to-High clock transition  
 X = Don't care  
 ↑ = Low-to-High clock transition

### LOGIC DIAGRAM

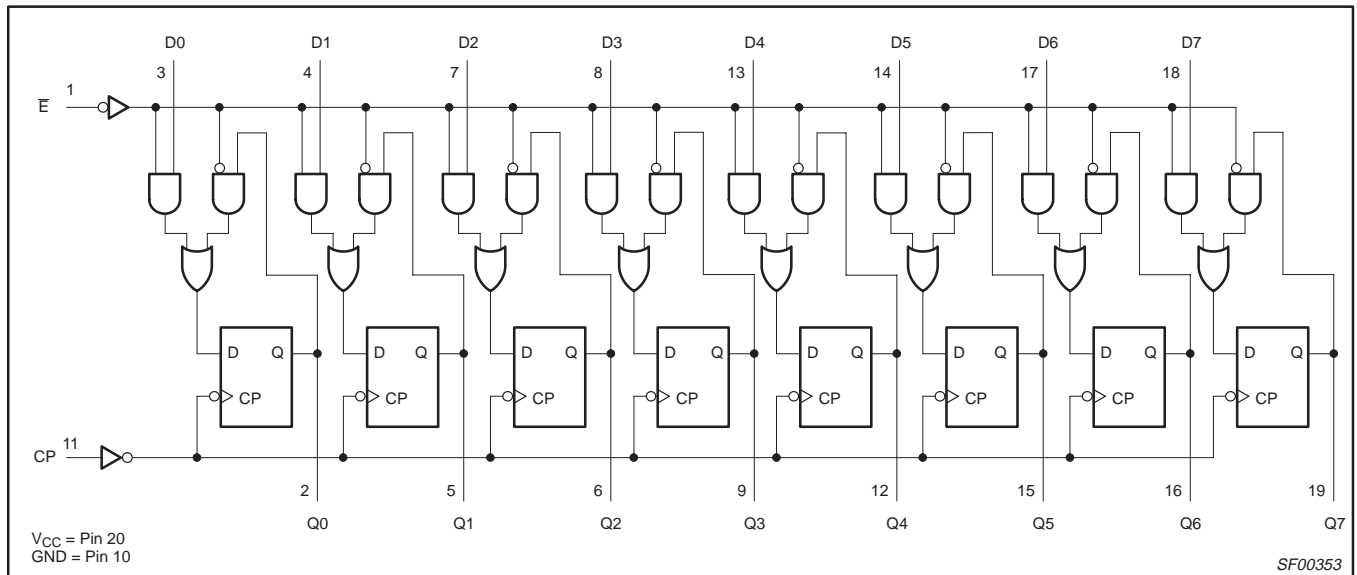

## Octal D-type flip-flop with enable

74F377A

**ABSOLUTE MAXIMUM RATINGS**

(Operation beyond the limit set forth in this table may impair the useful life of the device.)

Unless otherwise noted these limits are over the operating free air temperature range.)

SYMBOL	PARAMETER	RATING	UNIT
$V_{CC}$	Supply voltage	-0.5 to +7.0	V
$V_{IN}$	Input voltage	-0.5 to +7.0	V
$I_{IN}$	Input current	-30 to +5	mA
$V_{OUT}$	Voltage applied to output in High output state	-0.5 to $V_{CC}$	V
$I_{OUT}$	Current applied to output in Low output state	40	mA
$T_{amb}$	Operating free air temperature range	0 to +70	°C
$T_{stg}$	Storage temperature range	-65 to +150	°C

**RECOMMENDED OPERATING CONDITIONS**

SYMBOL	PARAMETER	LIMITS			UNIT
		MIN	NOM	MAX	
$V_{CC}$	Supply voltage	4.5	5.0	5.5	V
$V_{IH}$	High-level input voltage	2.0			V
$V_{IL}$	Low-level input voltage			0.8	V
$I_{IK}$	Input clamp current			-18	mA
$I_{OH}$	High-level output current			-1	mA
$I_{OL}$	Low-level output current			20	mA
$T_{amb}$	Operating free air temperature range	0		+70	°C

**DC ELECTRICAL CHARACTERISTICS**

(Over recommended operating free-air temperature range unless otherwise noted.)

SYMBOL	PARAMETER		TEST CONDITIONS <sup>1</sup>	LIMITS			UNIT
				MIN	TYP <sup>2</sup>	MAX	
$V_{OH}$	High-level output voltage	E & CP inputs	$V_{CC} = \text{MIN}, V_{IL} = 0.0V^3,$ $V_{IH} = 4.5V^3, I_{OH} = \text{MAX}$	$\pm 10\%V_{CC}$	2.5		V
				$\pm 5\%V_{CC}$	2.7	3.4	V
		Other inputs	$V_{CC} = \text{MIN}, V_{IL} = \text{MAX},$ $V_{IH} = \text{MIN}, I_{OH} = \text{MAX}$	$\pm 10\%V_{CC}$	2.5		V
				$\pm 5\%V_{CC}$	2.7		V
$V_{OL}$	Low-level output voltage	$V_{CC} = \text{MIN}, V_{IL} = \text{MAX},$ $V_{IH} = \text{MIN}, I_{OL} = \text{MAX}$	$\pm 10\%V_{CC}$		0.35	0.50	V
			$\pm 5\%V_{CC}$		0.35	0.50	V
$V_{IK}$	Input clamp voltage	$V_{CC} = \text{MIN}, I_I = I_{IK}$		-0.73	-1.2	V	
$I_I$	Input current at maximum input voltage	$V_{CC} = 0.0V, V_I = 7.0V$			100	$\mu\text{A}$	
$I_{IH}$	High-level input current	$V_{CC} = \text{MAX}, V_I = 2.7V$			20	$\mu\text{A}$	
$I_{IL}$	Low-level input current	$V_{CC} = \text{MAX}, V_I = 0.5V$			-20	$\mu\text{A}$	
$I_{OS}$	Short circuit output current <sup>4</sup>	$V_{CC} = \text{MAX}$		-60		-150	mA
$I_{CC}$	Supply current (total)	$I_{CCH}$	$V_{CC} = \text{MAX}$		27	40	mA
		$I_{CCL}$	$V_{CC} = \text{MAX}$		29	43	mA

**Notes to DC electrical characteristics**

- For conditions shown as MIN or MAX, use the appropriate value specified under recommended operating conditions for the applicable type.
- All typical values are at  $V_{CC} = 5V, T_{amb} = 25^\circ\text{C}$ .
- To reduce the effect of external noise during test. Special test conditions are not necessary for the '377A.
- Not more than one output should be shorted at a time. For testing  $I_{OS}$ , the use of high-speed test apparatus and/or sample-and-hold techniques are preferable in order to minimize internal heating and more accurately reflect operational values. Otherwise, prolonged shorting of a high output may raise the chip temperature well above normal and thereby cause invalid readings in other parameter tests. In any sequence of parameter tests,  $I_{OS}$  tests should be performed last.

# Octal D-type flip-flop with enable

74F377A

## AC CHARACTERISTICS

SYMBOL	PARAMETER	WAVEFORM	LIMITS				UNIT	
			T <sub>amb</sub> = +25°C V <sub>CC</sub> = +5.0V C <sub>L</sub> = 50pF R <sub>L</sub> = 500Ω			T <sub>amb</sub> = 0°C to +70°C V <sub>CC</sub> = +5.0V ±10% C <sub>L</sub> = 50pF R <sub>L</sub> = 500Ω		
			MIN	TYP	MAX	MIN		MAX
f <sub>MAX</sub>	Maximum clock frequency	1	150	165		120	MHz	
t <sub>PLH</sub> t <sub>PHL</sub>	Propagation delay CP to Qn	1	3.0 4.5	5.0 6.5	8.0 9.0	2.5 4.0	9.0 10.5	ns

## AC SETUP REQUIREMENTS

SYMBOL	PARAMETER	WAVEFORM	LIMITS				UNIT	
			T <sub>amb</sub> = +25°C V <sub>CC</sub> = +5.0V C <sub>L</sub> = 50pF R <sub>L</sub> = 500Ω			T <sub>amb</sub> = 0°C to +70°C V <sub>CC</sub> = +5.0V ±10% C <sub>L</sub> = 50pF R <sub>L</sub> = 500Ω		
			MIN	TYP	MAX	MIN		MAX
t <sub>s</sub> (H) t <sub>s</sub> (L)	Setup time, High or Low Dn to CP	2	2.5 2.5			2.5 2.5	ns	
t <sub>h</sub> (H) t <sub>h</sub> (L)	Hold time, High or Low Dn to CP	2	1.0 0.0			1.0 0.0	ns	
t <sub>s</sub> (H) t <sub>s</sub> (L)	Setup time, High or Low E to CP	2	3.0 4.0			3.0 4.5	ns	
t <sub>h</sub> (H) t <sub>h</sub> (L)	Hold time, High or Low E to CP	2	0.0 0.0			0.0 0.0	ns	
t <sub>w</sub> (H) t <sub>w</sub> (L)	Clock Pulse width High or Low	1	4.0 4.0			5.0 4.0	ns	

## AC WAVEFORMS

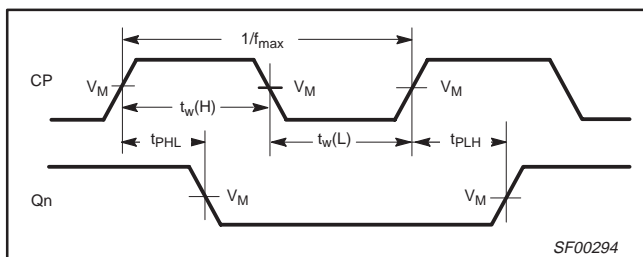

**Waveform 1. Propagation Delay, Clock Input to Output, Clock Pulse Width and Maximum Clock Frequency**

**NOTE:** For all waveforms, V<sub>M</sub> = 1.5V.  
The shaded areas indicate when the input is permitted to change for predictable output performance.

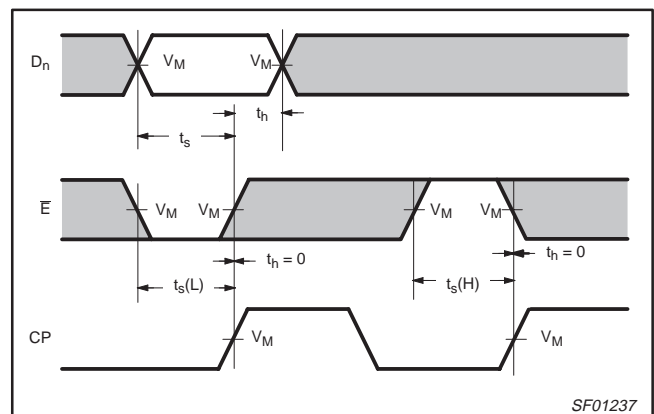

**Waveform 2. Data and Enable Setup and Hold Times**

# Octal D-type flip-flop with enable

# 74F377A

## TEST CIRCUIT AND WAVEFORM

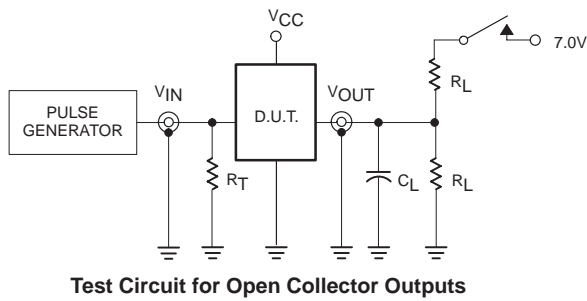

Test Circuit for Open Collector Outputs

### SWITCH POSITION

TEST	SWITCH
$t_{PLZ}$	closed
$t_{PZL}$	closed
All other	open

### DEFINITIONS:

- $R_L$  = Load resistor; see AC electrical characteristics for value.
- $C_L$  = Load capacitance includes jig and probe capacitance; see AC electrical characteristics for value.
- $R_T$  = Termination resistance should be equal to  $Z_{OUT}$  of pulse generators.

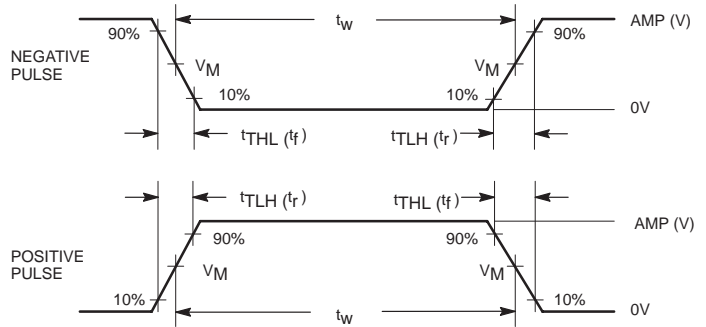

Input Pulse Definition

family	INPUT PULSE REQUIREMENTS					
	amplitude	$V_M$	rep. rate	$t_w$	$t_{TLH}$	$t_{THL}$
74F	3.0V	1.5V	1MHz	500ns	2.5ns	2.5ns

SF00128

# Octal D-type flip-flop with enable

## 74F377A

DIP20: plastic dual in-line package; 20 leads (300 mil)

SOT146-1

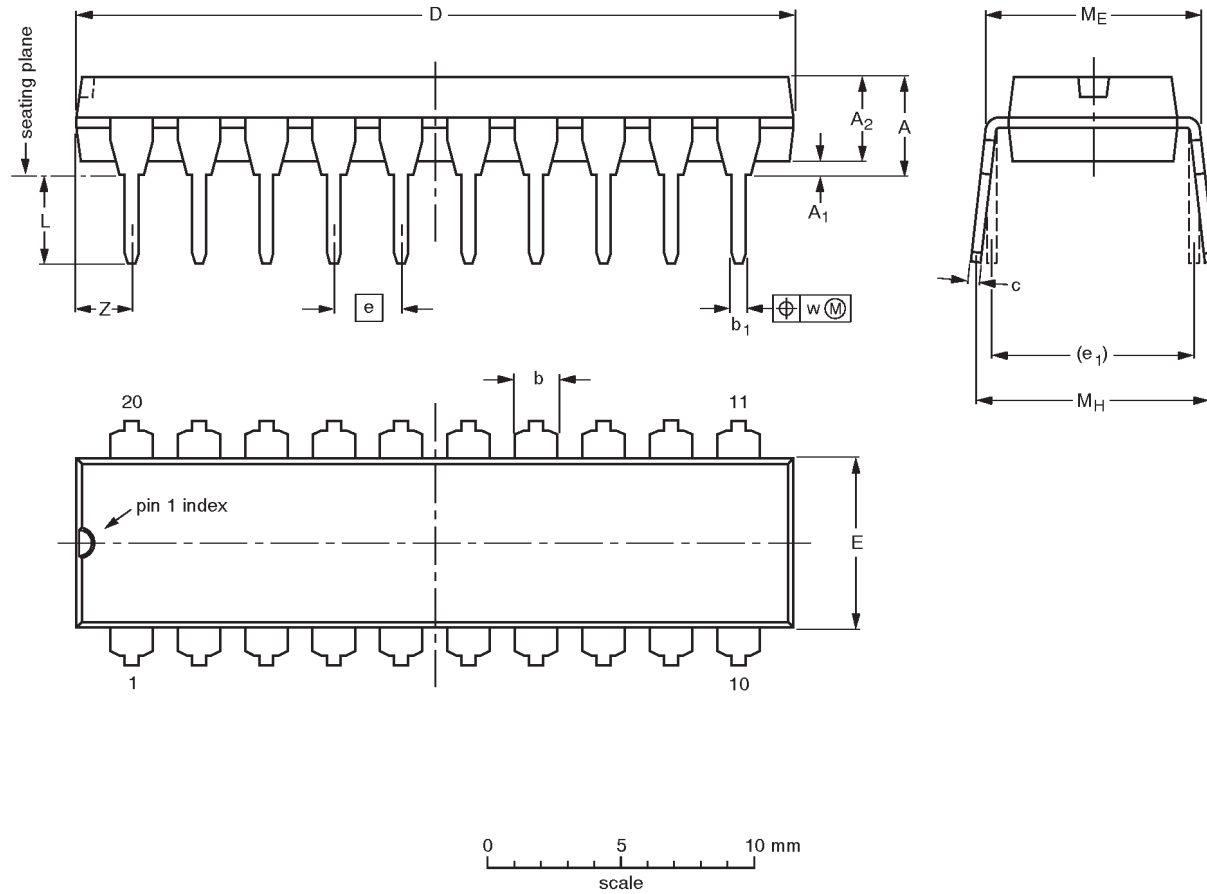

**DIMENSIONS** (inch dimensions are derived from the original mm dimensions)

UNIT	A max.	A <sub>1</sub> min.	A <sub>2</sub> max.	b	b <sub>1</sub>	c	D <sup>(1)</sup>	E <sup>(1)</sup>	e	e <sub>1</sub>	L	M <sub>E</sub>	M <sub>H</sub>	w	Z <sup>(1)</sup> max.
mm	4.2	0.51	3.2	1.73 1.30	0.53 0.38	0.36 0.23	26.92 26.54	6.40 6.22	2.54	7.62	3.60 3.05	8.25 7.80	10.0 8.3	0.254	2.0
inches	0.17	0.020	0.13	0.068 0.051	0.021 0.015	0.014 0.009	1.060 1.045	0.25 0.24	0.10	0.30	0.14 0.12	0.32 0.31	0.39 0.33	0.01	0.078

**Note**

1. Plastic or metal protrusions of 0.25 mm maximum per side are not included.

OUTLINE VERSION	REFERENCES				EUROPEAN PROJECTION	ISSUE DATE
	IEC	JEDEC	EIAJ			
SOT146-1			SC603			92-11-17 95-05-24

# Octal D-type flip-flop with enable

## 74F377A

**SO20:** plastic small outline package; 20 leads; body width 7.5 mm

**SOT163-1**

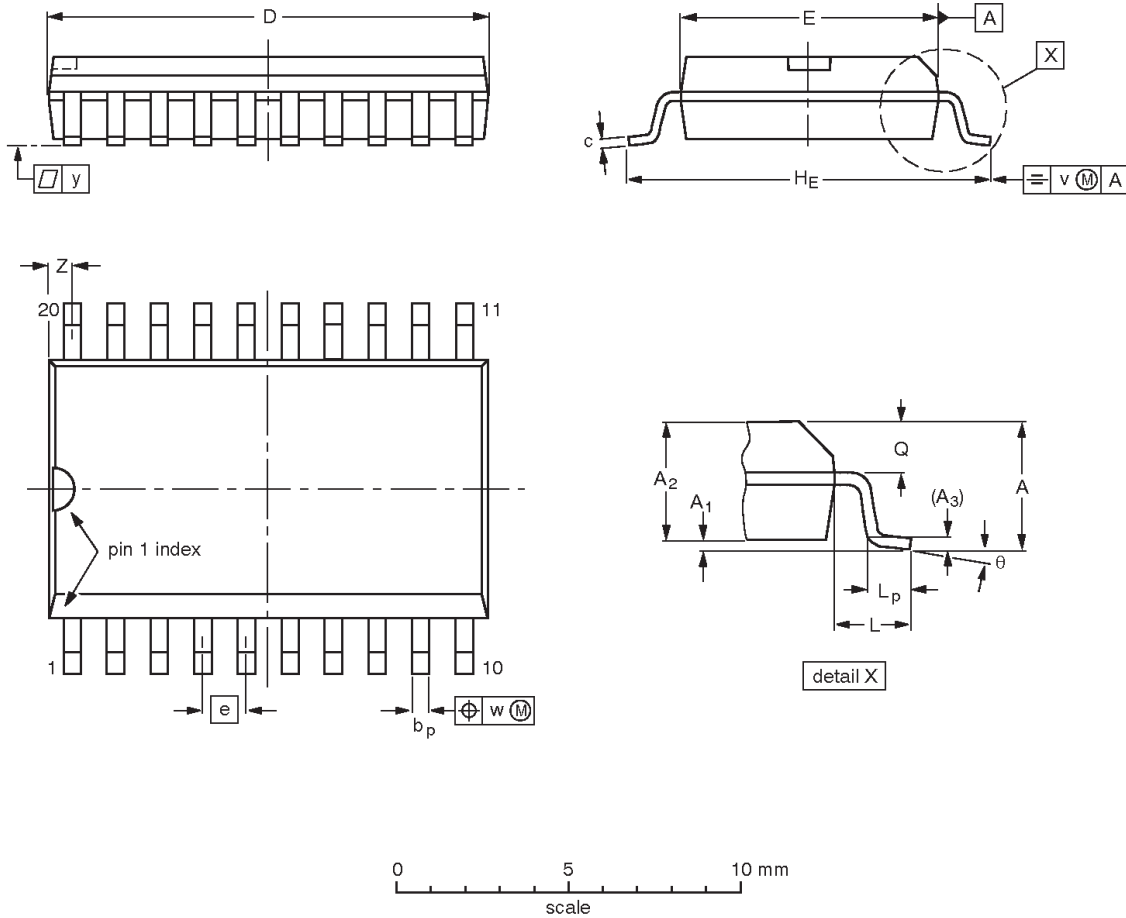

**DIMENSIONS (inch dimensions are derived from the original mm dimensions)**

UNIT	A max.	A <sub>1</sub>	A <sub>2</sub>	A <sub>3</sub>	b <sub>p</sub>	c	D <sup>(1)</sup>	E <sup>(1)</sup>	e	H <sub>E</sub>	L	L <sub>p</sub>	Q	v	w	y	z <sup>(1)</sup>	θ
mm	2.65	0.30 0.10	2.45 2.25	0.25	0.49 0.36	0.32 0.23	13.0 12.6	7.6 7.4	1.27	10.65 10.00	1.4	1.1 0.4	1.1 1.0	0.25	0.25	0.1	0.9 0.4	8° 0°
inches	0.10	0.012 0.004	0.096 0.089	0.01	0.019 0.014	0.013 0.009	0.51 0.49	0.30 0.29	0.050	0.419 0.394	0.055	0.043 0.016	0.043 0.039	0.01	0.01	0.004	0.035 0.016	

**Note**

1. Plastic or metal protrusions of 0.15 mm maximum per side are not included.

OUTLINE VERSION	REFERENCES				EUROPEAN PROJECTION	ISSUE DATE
	IEC	JEDEC	EIAJ			
SOT163-1	075E04	MS-013AC				95-01-24 97-05-22

---

Octal D-type flip-flop with enable

74F377A

---

**NOTES**

## Octal D-type flip-flop with enable

74F377A

## Data sheet status

Data sheet status	Product status	Definition [1]
Objective specification	Development	This data sheet contains the design target or goal specifications for product development. Specification may change in any manner without notice.
Preliminary specification	Qualification	This data sheet contains preliminary data, and supplementary data will be published at a later date. Philips Semiconductors reserves the right to make changes at any time without notice in order to improve design and supply the best possible product.
Product specification	Production	This data sheet contains final specifications. Philips Semiconductors reserves the right to make changes at any time without notice in order to improve design and supply the best possible product.

[1] Please consult the most recently issued datasheet before initiating or completing a design.

## Definitions

**Short-form specification** — The data in a short-form specification is extracted from a full data sheet with the same type number and title. For detailed information see the relevant data sheet or data handbook.

**Limiting values definition** — Limiting values given are in accordance with the Absolute Maximum Rating System (IEC 134). Stress above one or more of the limiting values may cause permanent damage to the device. These are stress ratings only and operation of the device at these or at any other conditions above those given in the Characteristics sections of the specification is not implied. Exposure to limiting values for extended periods may affect device reliability.

**Application information** — Applications that are described herein for any of these products are for illustrative purposes only. Philips Semiconductors make no representation or warranty that such applications will be suitable for the specified use without further testing or modification.

## Disclaimers

**Life support** — These products are not designed for use in life support appliances, devices or systems where malfunction of these products can reasonably be expected to result in personal injury. Philips Semiconductors customers using or selling these products for use in such applications do so at their own risk and agree to fully indemnify Philips Semiconductors for any damages resulting from such application.

**Right to make changes** — Philips Semiconductors reserves the right to make changes, without notice, in the products, including circuits, standard cells, and/or software, described or contained herein in order to improve design and/or performance. Philips Semiconductors assumes no responsibility or liability for the use of any of these products, conveys no license or title under any patent, copyright, or mask work right to these products, and makes no representations or warranties that these products are free from patent, copyright, or mask work right infringement, unless otherwise specified.

Philips Semiconductors  
811 East Arques Avenue  
P.O. Box 3409  
Sunnyvale, California 94088-3409  
Telephone 800-234-7381

© Copyright Philips Electronics North America Corporation 1998  
All rights reserved. Printed in U.S.A.

print code

Date of release: 10-98

Document order number:

9397-750-05121

*Let's make things better.*



LittleDiode supplies new, hard to find or obsolete electronic components and semiconductors all over the world.

With over two million different components listed you are sure to find the part you need.

Feel free to visit us today at our online store:

[LittleDiode.com](http://LittleDiode.com)

Looking forward to providing you with the best possible service.