

54F/74F322 Octal Serial/Parallel Register with Sign Extend

General Description

The 'F322 is an 8-bit shift register with provision for either serial or parallel loading and with TRI-STATE® parallel outputs plus a bi-state serial output. Parallel data inputs and parallel outputs are multiplexed to minimize pin count. State changes are initiated by the rising edge of the clock. Four synchronous modes of operation are possible: hold (store), shift right with serial entry, shift right with sign extend and parallel load. An asynchronous Master Reset (\overline{MR}) input overrides clocked operation and clears the register.

Features

- Multiplexed parallel I/O ports
- Separate serial input and output
- Sign extend function
- TRI-STATE outputs for bus applications

Commercial	Military	Package Number	Package Description
74F322PC		N20A	20-Lead (0.300" Wide) Molded Dual-In-Line
	54F322DM (Note 2)	J20A	20-Lead Ceramic Dual-In-Line
74F322SJ (Note 1)		M20D	20-Lead (0.300" Wide) Molded Small Outline, EIAJ
	54F322FM (Note 2)	W20A	20-Lead Cerpack
	54F322LM (Note 2)	E20A	20-Lead Ceramic Leadless Chip Carrier, Type C

Note 1: Devices also available in 13" reel. Use suffix = SJX.

Note 2: Military grade device with environmental and burn-in processing. Use suffix = DMQB, FMQB and LMQB.

Logic Symbols

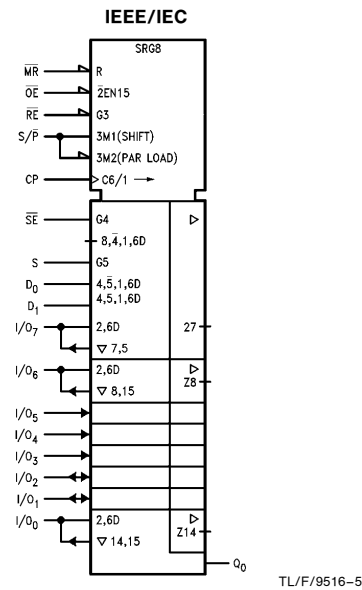
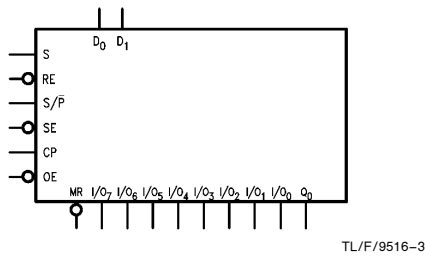

TRI-STATE® is a registered trademark of National Semiconductor Corporation.

Unit Loading/Fan Out

Pin Names	Description	54F/74F	
		U.L. HIGH/LOW	Input I _H /I _L Output I _{OH} /I _{OL}
\overline{RE}	Register Enable Input (Active LOW)	1.0/1.0	20 μ A/ -0.6 mA
S/ \overline{P}	Serial (HIGH) or Parallel (LOW) Mode Control Input	1.0/1.0	20 μ A/ -0.6 mA
\overline{SE}	Sign Extend Input (Active LOW)	1.0/3.0	20 μ A/ -1.8 mA
S	Serial Data Select Input	1.0/2.0	20 μ A/ -1.2 mA
D ₀ , D ₁	Serial Data Inputs	1.0/1.0	20 μ A/ -0.6 mA
CP	Clock Pulse Input (Active Rising Edge)	1.0/1.0	20 μ A/ -0.6 mA
\overline{MR}	Asynchronous Master Reset Input (Active LOW)	1.0/1.0	20 μ A/ -0.6 mA
\overline{OE}	TRI-STATE Output Enable Input (Active LOW)	1.0/1.0	20 μ A/ -0.6 mA
Q ₀	Bi-State Serial Output	50/33.3	-1 mA/ -20 mA
I/O ₀ -I/O ₇	Multiplexed Parallel Data Inputs or TRI-STATE Parallel Data Outputs	3.5/1.083 150/40 (33.3)	70 μ A/ -0.65 mA -3 mA/24 mA (20 mA)

Functional Description

The 'F322 contains eight D-type edge triggered flip-flops and the interstage gating required to perform right shift and the intrastage gating necessary for hold and synchronous parallel load operations. A LOW signal on \overline{RE} enables shifting or parallel loading, while a HIGH signal enables the hold mode. A HIGH signal on S/ \overline{P} enables shift right, while a LOW signal disables the TRI-STATE output buffers and enables parallel loading. In the shift right mode a HIGH signal

on \overline{SE} enables serial entry from either D₀ or D₁, as determined by the S input. A LOW signal on \overline{SE} enables shift right but Q₇ reloads its contents, thus performing the sign extend function required for the 'F384 Twos Complement Multiplier. A HIGH signal on \overline{OE} disables the TRI-STATE output buffers, regardless of the other control inputs. In this condition the shifting and loading operations can still be performed.

Mode Select Table

Mode	Inputs							Outputs							Q ₀	
	\overline{MR}	\overline{RE}	S/ \overline{P}	\overline{SE}	S	\overline{OE} *	CP	I/O ₇	I/O ₆	I/O ₅	I/O ₄	I/O ₃	I/O ₂	I/O ₁		I/O ₀
Clear	L	X	X	X	X	L	X	L	L	L	L	L	L	L	L	L
	L	X	X	X	X	H	X	Z	Z	Z	Z	Z	Z	Z	Z	Z
Parallel Load	H	L	L	X	X	X	\nearrow	I ₇	I ₆	I ₅	I ₄	I ₃	I ₂	I ₁	I ₀	I ₀
Shift Right	H	L	H	H	L	L	\nearrow	D ₀	O ₇	O ₆	O ₅	O ₄	O ₃	O ₂	O ₁	O ₁
	H	L	H	H	H	L	\nearrow	D ₁	O ₇	O ₆	O ₅	O ₄	O ₃	O ₂	O ₁	O ₁
Sign Extend	H	L	H	L	X	L	\nearrow	O ₇	O ₇	O ₆	O ₅	O ₄	O ₃	O ₂	O ₁	O ₁
Hold	H	H	X	X	X	L	\nearrow	NC	NC	NC	NC	NC	NC	NC	NC	NC

*When the \overline{OE} input is HIGH all I/O_n terminals are at the high impedance state; sequential operation or clearing of the register is not affected.

Note 1: I₇-I₀ = The level of the steady-state input at the respective I/O terminal is loaded into the flip-flop while the flip-flop outputs (except Q₀) are isolated from the I/O terminal.

Note 2: D₀, D₁ = The level of the steady-state inputs to the serial multiplexer input.

Note 3: O₇-O₀ = The level of the respective Q_n flip-flop prior to the last Clock LOW-to-HIGH transition.

H = HIGH Voltage Level

L = LOW Voltage Level

Z = High Impedance Output State

\nearrow = LOW-to-HIGH Transition

NC = No Change

Logic Diagram

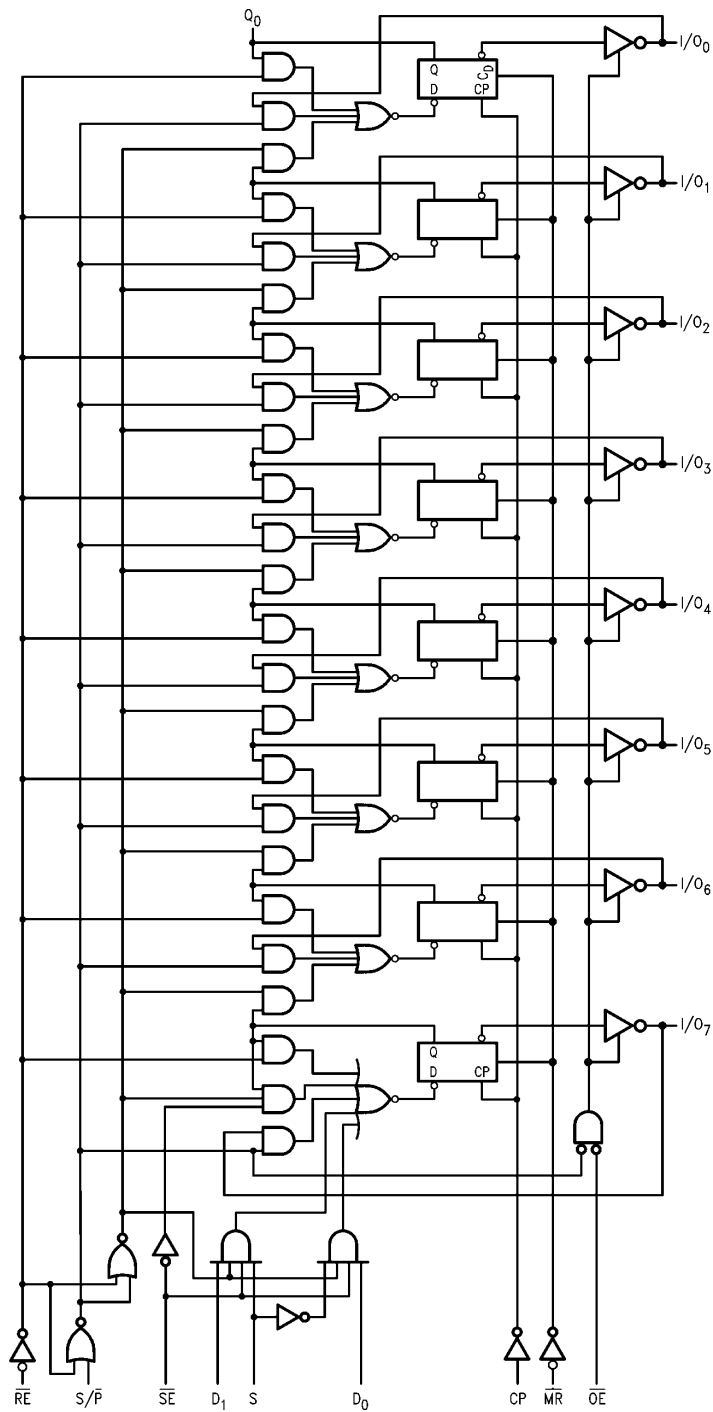

TL/F/9516-4

Please note that this diagram is provided only for the understanding of logic operations and should not be used to estimate propagation delays.

Absolute Maximum Ratings (Note 1)

If Military/Aerospace specified devices are required, please contact the National Semiconductor Sales Office/Distributors for availability and specifications.

Storage Temperature	-65°C to +150°C
Ambient Temperature under Bias	-55°C to +125°C
Junction Temperature under Bias	-55°C to +175°C
Plastic	-55°C to +150°C
V _{CC} Pin Potential to Ground Pin	-0.5V to +7.0V
Input Voltage (Note 2)	-0.5V to +7.0V
Input Current (Note 2)	-30 mA to +5.0 mA

Note 1: Absolute maximum ratings are values beyond which the device may be damaged or have its useful life impaired. Functional operation under these conditions is not implied.

Note 2: Either voltage limit or current limit is sufficient to protect inputs.

Voltage Applied to Output in HIGH State (with V _{CC} = 0V)	-0.5V to V _{CC}
Standard Output	-0.5V to +5.5V
TRI-STATE Output	-0.5V to +5.5V

Current Applied to Output in LOW State (Max) twice the rated I_{OL} (mA)

Recommended Operating Conditions

Free Air Ambient Temperature	-55°C to +125°C
Military	0°C to +70°C
Commercial	

Supply Voltage	+4.5V to +5.5V
Military	+4.5V to +5.5V
Commercial	+4.5V to +5.5V

DC Electrical Characteristics

Symbol	Parameter	54F/74F			Units	V _{CC}	Conditions
		Min	Typ	Max			
V _{IH}	Input HIGH Voltage	2.0			V		Recognized as a HIGH Signal
V _{IL}	Input LOW Voltage				V		Recognized as a LOW Signal
V _{CD}	Input Clamp Diode Voltage				V	Min	I _{IN} = -18 mA
V _{OH}	Output HIGH Voltage	54F 10% V _{CC}	2.5		V	Min	I _{OH} = -1 mA (Q ₀ , I/O _n) I _{OH} = -3 mA (I/O _n) I _{OH} = -1 mA (Q ₀ , I/O _n) I _{OH} = -3 mA (I/O _n) I _{OH} = -1 mA (Q ₀ , I/O _n) I _{OH} = -3 mA (I/O _n)
		54F 10% V _{CC}	2.4				
		74F 10% V _{CC}	2.5				
		74F 10% V _{CC}	2.4				
		74F 5% V _{CC}	2.7				
		74F 5% V _{CC}	2.7				
V _{OL}	Output LOW Voltage	54F 10% V _{CC}	0.5		V	Min	I _{OL} = 20 mA (Q ₀ , I/O _n) I _{OL} = 20 mA (Q ₀) I _{OL} = 24 mA (I/O _n)
		74F 10% V _{CC}	0.5				
		74F 10% V _{CC}	0.5				
I _{IH}	Input HIGH Current	54F	20.0		μA	Max	V _{IN} = 2.7V
		74F	5.0				
I _{BVI}	Input HIGH Current Breakdown Test	54F	100		μA	Max	V _{IN} = 7.0V (Non-I/O Inputs)
		74F	7.0				
I _{BVIT}	Input HIGH Current Breakdown Test (I/O)	54F	1.0		mA	Max	V _{IN} = 5.5V (I/O _n)
		74F	0.5				
I _{CEX}	Output HIGH Leakage Current	54F	250		μA	Max	V _{OUT} = V _{CC}
		74F	50				
V _{ID}	Input Leakage Test	74F	4.75		V	0.0	I _{ID} = 1.9 μA All Other Pins Grounded
I _{OD}	Output Leakage Circuit Current	74F	3.75		μA	0.0	V _{IOD} = 150 mV All Other Pins Grounded
I _{IL}	Input LOW Current			-0.6	mA	Max	V _{IN} = 0.5V (RE, S/P, D _n , CP, MR, OE)
				-1.2			
				-1.8			
I _{IH} + I _{OZH}	Output Leakage Current			70	μA	Max	V _{I/O} = 2.7V (I/O _n)
I _{IL} + I _{OZL}	Output Leakage Current			-650	μA	Max	V _{I/O} = 0.5V (I/O _n)
I _{OS}	Output Short-Circuit Current			-60	mA	Max	V _{OUT} = 0V
				-150			
I _{ZZ}	Bus Drainage Test			500	μA	0.0V	V _{OUT} = 5.25V
I _{CC}	Power Supply Current			60	mA	Max	
				90			

AC Electrical Characteristics

Symbol	Parameter	74F			54F		74F		Units
		T _A = +25°C V _{CC} = +5.0V C _L = 50 pF			T _A , V _{CC} = Mil C _L = 50 pF		T _A , V _{CC} = Com C _L = 50 pF		
		Min	Typ	Max	Min	Max	Min	Max	
f _{max}	Maximum Clock Frequency	70	90		50		70		MHz
t _{PLH}	Propagation Delay CP to I/O _n	3.5	7.0	7.5	3.5	9.5	3.5	8.5	ns
t _{PHL}	Propagation Delay CP to I/O _n	5.0	8.5	11.0	3.5	10.0	5.0	12.0	
t _{PLH}	Propagation Delay CP to Q ₀	3.5	7.0	9.0	3.5	11.0	3.5	10.0	ns
t _{PHL}	Propagation Delay CP to Q ₀	3.5	7.0	8.0	3.5	10.0	3.5	9.0	
t _{PHL}	Propagation Delay MR to I/O _n	6.0	10.0	13.0	6.0	15.0	6.0	14.0	ns
t _{PHL}	Propagation Delay MR to Q ₀	5.5	7.5	12.0	5.5	14.0	5.5	13.0	ns
t _{PZH}	Output Enable Time OE to I/O _n	3.0	6.5	9.0	3.0	12.5	3.0	10.0	ns
t _{PZL}	Output Enable Time OE to I/O _n	4.0	8.5	11.0	4.0	14.5	4.0	12.0	
t _{PHZ}	Output Disable Time OE to I/O _n	2.0	4.5	6.0	2.0	8.0	2.0	7.0	ns
t _{PLZ}	Output Disable Time OE to I/O _n	2.0	5.0	7.0	2.0	10.0	2.0	8.0	
t _{PZH}	Output Enable Time S/P to I/O _n	4.5	8.0	10.5	4.5	13.5	4.5	11.5	ns
t _{PZL}	Output Enable Time S/P to I/O _n	5.5	10.0	14.0	5.5	17.0	5.5	15.0	
t _{PHZ}	Output Disable Time S/P to I/O _n	5.0	9.0	11.5	5.0	16.5	5.0	12.5	ns
t _{PLZ}	Output Disable Time S/P to I/O _n	6.0	12.0	15.5	6.0	19.5	6.0	16.5	

AC Operating Requirements

Symbol	Parameter	74F		54F		74F		Units
		T _A = +25°C V _{CC} = +5.0V		T _A , V _{CC} = Mil		T _A , V _{CC} = Com		
		Min	Max	Min	Max	Min	Max	
t _s (H)	Setup Time, HIGH or LOW RE to CP	6.0		14.0		7.0		ns
t _s (L)	Setup Time, HIGH or LOW RE to CP	14.0		18.0		16.0		
t _h (H)	Hold Time, HIGH or LOW RE to CP	0		0		0		ns
t _h (L)	Hold Time, HIGH or LOW RE to CP	0		0		0		
t _s (H)	Setup Time, HIGH or LOW D ₀ , D ₁ or I/O _n to CP	6.5		8.5		7.5		ns
t _s (L)	Setup Time, HIGH or LOW D ₀ , D ₁ or I/O _n to CP	6.5		8.5		7.5		
t _h (H)	Hold Time, HIGH or LOW D ₀ , D ₁ or I/O _n to CP	2.0		3.0		3.0		ns
t _h (L)	Hold Time, HIGH or LOW D ₀ , D ₁ or I/O _n to CP	2.0		3.0		3.0		
t _s (H)	Setup Time, HIGH or LOW SE to CP	7.0		9.0		8.0		ns
t _s (L)	Setup Time, HIGH or LOW SE to CP	2.5		11.0		3.5		
t _h (H)	Hold Time, HIGH or LOW SE to CP	2.0		2.0		2.0		ns
t _h (L)	Hold Time, HIGH or LOW SE to CP	0.0		1.0		0.0		
t _s (H)	Setup Time, HIGH or LOW S/P to CP	11.0		13.0		12.0		ns
t _s (L)	Setup Time, HIGH or LOW S/P to CP	13.5		21.0		15.5		
t _s (H)	Setup Time, HIGH or LOW S to CP	6.5		8.5		7.5		ns
t _s (L)	Setup Time, HIGH or LOW S to CP	9.0		11.0		10.0		
t _h (H)	Hold Time, HIGH or LOW S or S/P to CP	0		1.0		0		ns
t _h (L)	Hold Time, HIGH or LOW S or S/P to CP	0		0		0		
t _w (H)	CP Pulse Width, HIGH or LOW	7.0		8.0		7.0		ns
t _w (L)	CP Pulse Width, HIGH or LOW	7.0		8.0		7.0		
t _w (L)	MR Pulse Width, LOW	5.5		7.5		6.5		ns
t _{rec}	Recovery Time MR to CP	8.0		12.0		8.0		ns

Ordering Information

The device number is used to form part of a simplified purchasing code where the package type and temperature range are defined as follows:

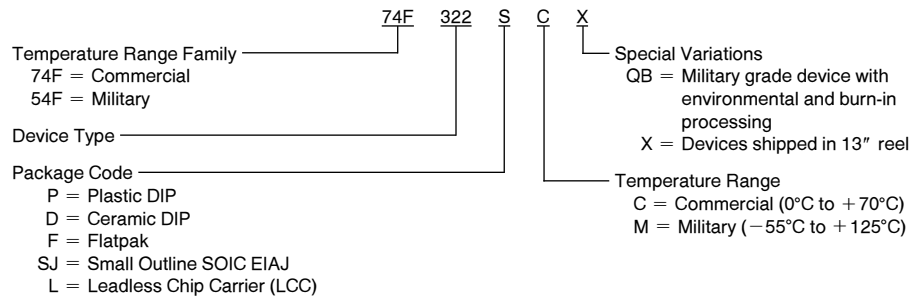

Physical Dimensions inches (millimeters)

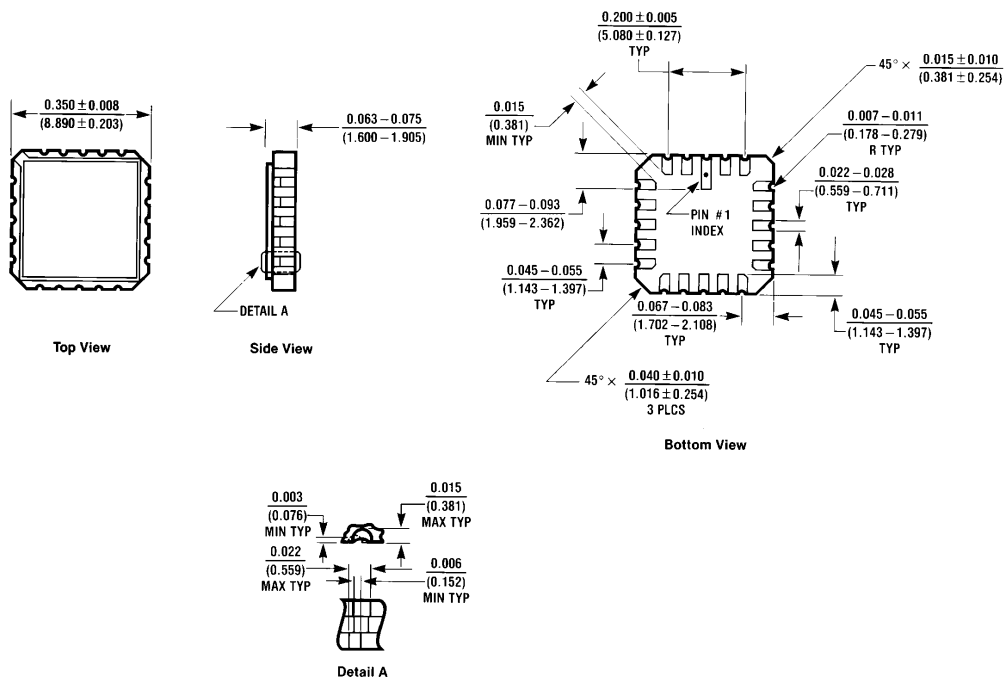

**20-Lead Ceramic Leadless Chip Carrier (L)
NS Package Number E20A**

E20A (REV D1)

Physical Dimensions inches (millimeters) (Continued)

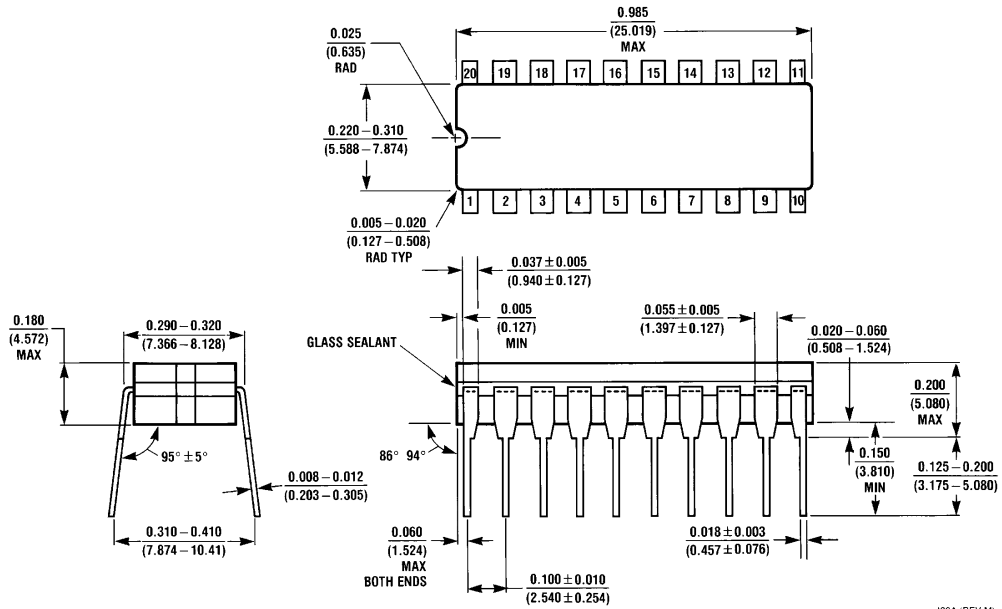

20-Lead Ceramic Dual-In-Line Package (D)
NS Package Number J20A

J20A (REV M)

Physical Dimensions inches (millimeters) (Continued)

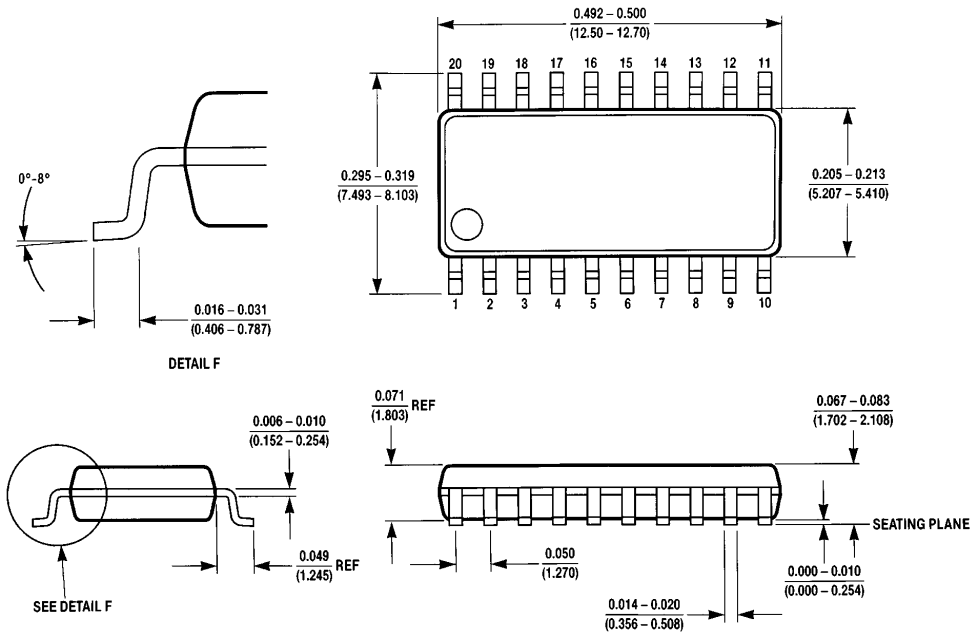

**20-Lead (0.300" Wide) Molded Small Outline Package, EIAJ (SJ)
NS Package Number M20D**

M20D (REV A)

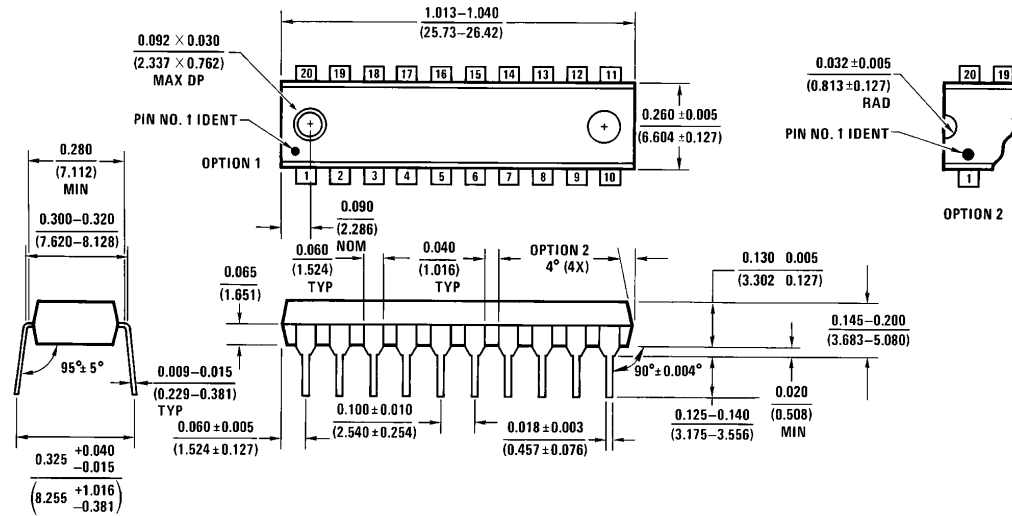

**20-Lead (0.300" Wide) Molded Dual-In-Line Package (P)
NS Package Number N20A**

N20A (REV G)

Physical Dimensions inches (millimeters) (Continued)

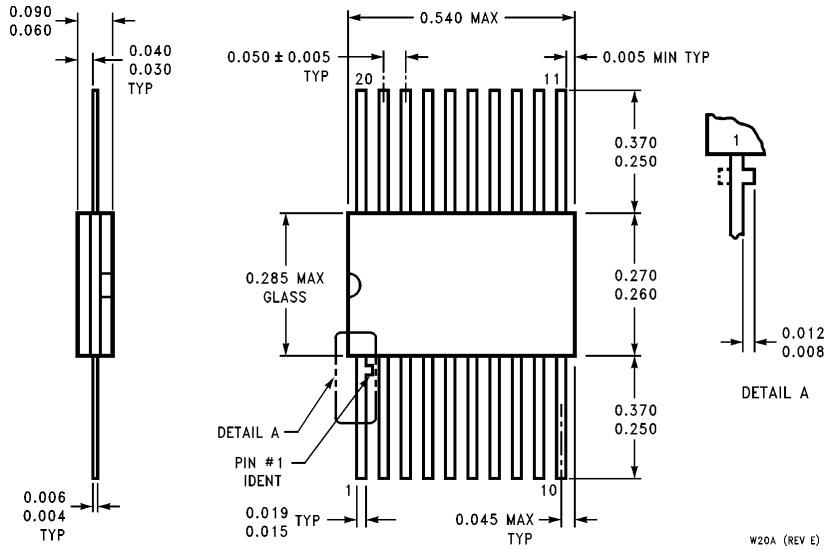

**20-Lead Ceramic Flatpak (F)
NS Package Number W20A**

LIFE SUPPORT POLICY

NATIONAL'S PRODUCTS ARE NOT AUTHORIZED FOR USE AS CRITICAL COMPONENTS IN LIFE SUPPORT DEVICES OR SYSTEMS WITHOUT THE EXPRESS WRITTEN APPROVAL OF THE PRESIDENT OF NATIONAL SEMICONDUCTOR CORPORATION. As used herein:

1. Life support devices or systems are devices or systems which, (a) are intended for surgical implant into the body, or (b) support or sustain life, and whose failure to perform, when properly used in accordance with instructions for use provided in the labeling, can be reasonably expected to result in a significant injury to the user.
2. A critical component is any component of a life support device or system whose failure to perform can be reasonably expected to cause the failure of the life support device or system, or to affect its safety or effectiveness.



National Semiconductor Corporation
1111 West Bardin Road
Arlington, TX 76017
Tel: 1(800) 272-9959
Fax: 1(800) 737-7018

National Semiconductor Europe
Fax: (+49) 0-180-530 85 86
Email: cnjwge@tevm2.nsc.com
Deutsch Tel: (+49) 0-180-530 85 85
English Tel: (+49) 0-180-532 78 32
Français Tel: (+49) 0-180-532 93 58
Italiano Tel: (+49) 0-180-534 16 80

National Semiconductor Hong Kong Ltd.
19th Floor, Straight Block,
Ocean Centre, 5 Canton Rd.
Tsimshatsui, Kowloon
Hong Kong
Tel: (852) 2737-1600
Fax: (852) 2736-9960

National Semiconductor Japan Ltd.
Tel: 81-043-299-2309
Fax: 81-043-299-2408

National does not assume any responsibility for use of any circuitry described, no circuit patent licenses are implied and National reserves the right at any time without notice to change said circuitry and specifications.

This datasheet has been downloaded from:

www.DatasheetCatalog.com

Datasheets for electronic components.

National Semiconductor was acquired by Texas Instruments.

http://www.ti.com/corp/docs/investor_relations/pr_09_23_2011_national_semiconductor.html

This file is the datasheet for the following electronic components:

74F322SJ - <http://www.ti.com/product/74f322sj?HQS=TI-null-null-dscatalog-df-pf-null-ww>

74F322PC - <http://www.ti.com/product/74f322pc?HQS=TI-null-null-dscatalog-df-pf-null-ww>



LittleDiode supplies new, hard to find or obsolete electronic components and semiconductors all over the world.

With over two million different components listed you are sure to find the part you need.

Feel free to visit us today at our online store:

LittleDiode.com

Looking forward to providing you with the best possible service.