

# DATA SHEET

**74F225**

**16X5 asynchronous FIFO (3-State)**

Product specification

1992 Jun 15

IC15 Data Handbook

**16 × 5 asynchronous FIFO (3-State)****74F225****FEATURES**

- Independent synchronous inputs and outputs
- Organized as 16 words of 5 bits
- DC to 25MHz data rate
- 3-State outputs
- Cascadable in word-width and depth direction

**DESCRIPTION**

This 80-bit active element First-In-First-Out (FIFO) is a monolithic Schottky-clamped transistor-transistor logic (STTL) array organized as 16-words of 5-bits each. A memory system using the 'F225 can be easily expanded in multiples of 16-words of 5-bits as shown in Figure 1. The 3-State outputs controlled by a single enable input ( $\overline{OE}$ ) make bus connection and multiplexing simple. The 'F225 processes data in a parallel format at any desired clock rate from DC to 25MHz. Status of the 'F225 is provided by three outputs, Input

Ready (IR), Unload Clock Output (UNCPOUT) and Output Ready (OR). The data outputs are non-inverting with respect to the data inputs and are disabled when the  $\overline{OE}$  input is High. When  $\overline{OE}$  is Low, the data outputs are enabled to function as totem-pole outputs.

TYPE	TYPICAL $f_{MAX}$	TYPICAL SUPPLY CURRENT (TOTAL)
74F225	25MHz	65mA

**ORDERING INFORMATION**

DESCRIPTION	ORDER CODE	PKG DWG #
	COMMERCIAL RANGE $V_{CC} = 5V \pm 10\%$ , $T_{amb} = 0^{\circ}C \text{ to } +70^{\circ}C$	
20-pin plastic DIP	N74F225N	SOT146-1
20-pin plastic SOL	N74F225D	SOT163-1

**INPUT AND OUTPUT LOADING AND FAN OUT TABLE**

PINS	DESCRIPTION	74F (U.L.) HIGH/LOW	LOAD VALUE HIGH/LOW
CPA, CPB	Load clock A and load clock B inputs	1.0/0.033	20 $\mu$ A/20 $\mu$ A
D0 – D4	Data inputs	1.0/0.033	20 $\mu$ A/20 $\mu$ A
$\overline{OE}$	Output enable input (active-Low)	1.0/0.033	20 $\mu$ A/20 $\mu$ A
UNCPIN	Unload clock input	1.0/0.033	20 $\mu$ A/20 $\mu$ A
$\overline{MR}$	Master reset input (active-Low)	1.0/0.033	20 $\mu$ A/20 $\mu$ A
IR	Input ready output	50/33	1.0mA/20mA
UNCPOUT	Unload clock output (active-Low)	50/33	1.0mA/20mA
Q0 – Q4	Data outputs	150/40	3.0mA/24mA
OR	Output ready output	50/33	1.0mA/20mA

**NOTE:** One (1.0) FAST unit load is defined as: 20 $\mu$ A in the High state and 0.6mA in the Low state.

**RESET MODE**

A High-to-Low transition on the Master Reset ( $\overline{MR}$ ) input invalidates all data stored in the FIFO by clearing the control logic and setting OR Low. This High-to-Low transition on the  $\overline{MR}$  input does not effect the data outputs but since OR is driven Low, it signifies invalid data on the outputs.

**WRITE MODE**

Data may be written into the array on the Low-to-High transition of either load clock (CPA or CPB) input. When writing data into the FIFO, one of the load clock inputs must be held High while the other strobes data into the FIFO. This arrangement allows either load clock to function as an inhibit for the other. Input Ready (IR) monitors the status of the last word location and signifies when the FIFO is full. This output is High whenever the FIFO is available to accept new data. The unload clock output (UNCPOUT) also monitors the last word location. This output generates a Low-logic-level pulse (synchronized to the internal clock pulse) when the last word location is vacant

**READ MODE**

The Output Ready (OR) output is High when valid data is present on the data outputs. Data in the array is shifted on the Low-to-High transition of the Unload Clock Input (UNCPIN). In order for Output Ready (OR) to go High, Unload Clock Input (UNCPIN) must also be High.

# 16 × 5 asynchronous FIFO (3-State)

# 74F225

## PIN CONFIGURATION

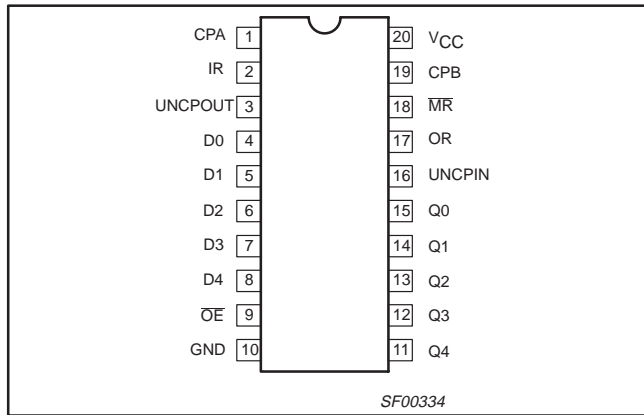

## IEC/IEEE SYMBOL

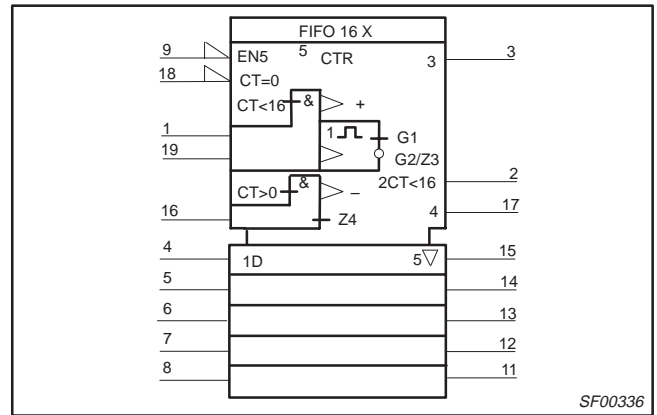

## LOGIC SYMBOL

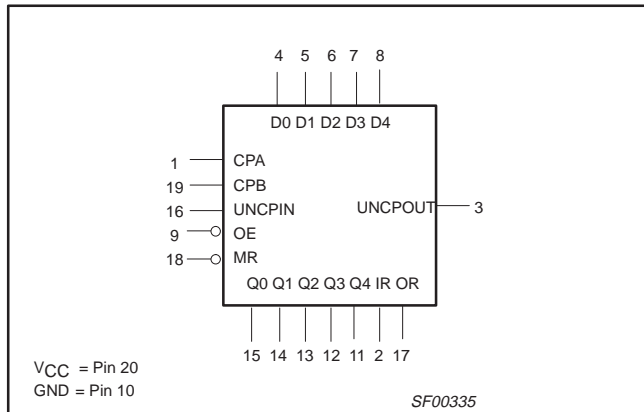

# 16 × 5 asynchronous FIFO (3-State)

## 74F225

### LOGIC DIAGRAM

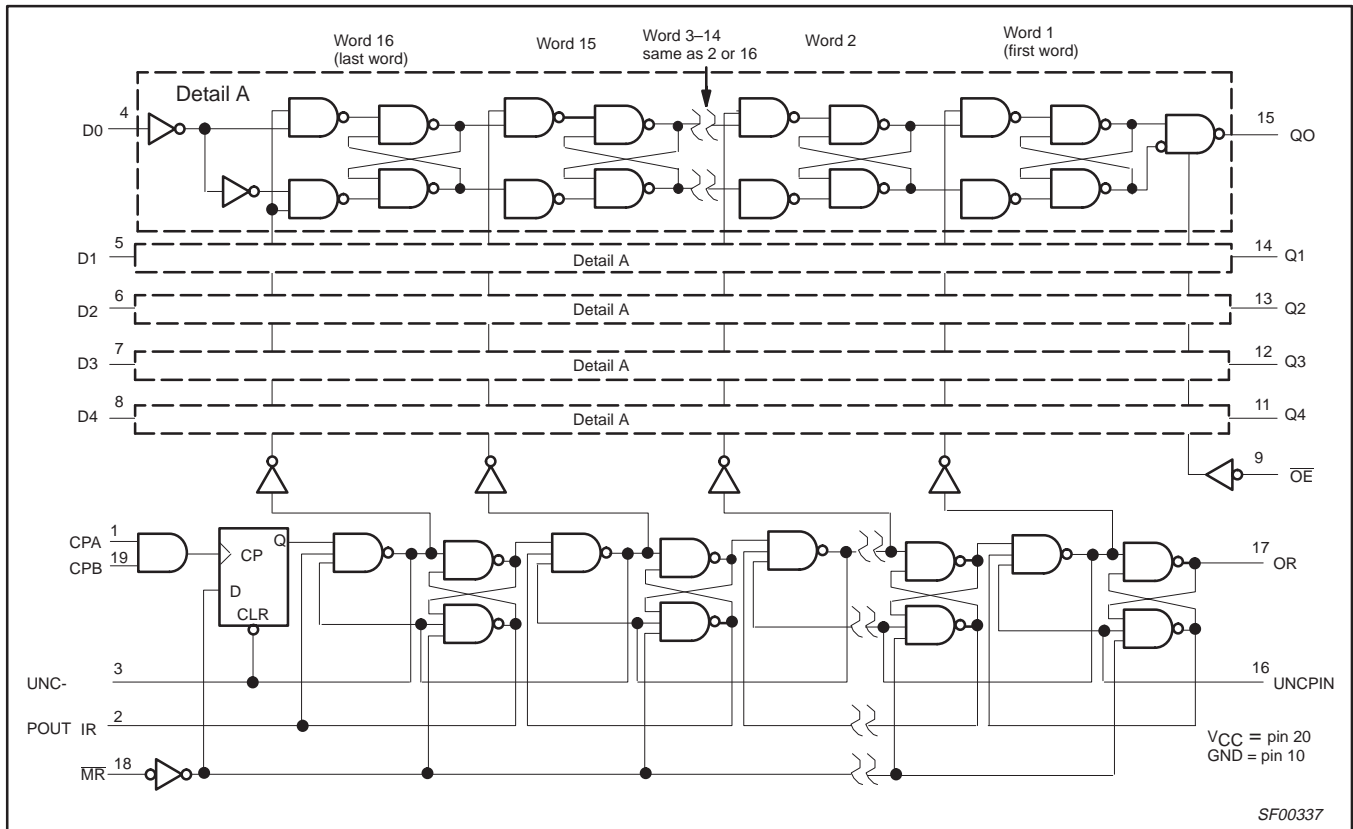

## 16 × 5 asynchronous FIFO (3-State)

74F225

**ABSOLUTE MAXIMUM RATINGS**

(Operation beyond the limit set forth in this table may impair the useful life of the device. Unless otherwise noted these limits are over the operating free air temperature range.)

SYMBOL	PARAMETER		RATING	UNIT
V <sub>CC</sub>	Supply voltage		-0.5 to +7.0	V
V <sub>IN</sub>	Input voltage		-0.5 to +7.0	V
I <sub>IN</sub>	Input current		-30 to +5	mA
V <sub>OUT</sub>	Voltage applied to output in High output state		-0.5 to V <sub>CC</sub>	V
I <sub>OUT</sub>	Current applied to output in Low output state	IR, OR, UNCPOUT	40	mA
	Current applied to output in Low output state	Data outputs	48	mA
T <sub>amb</sub>	Operating free air temperature range		0 to +70	°C
T <sub>stg</sub>	Storage temperature range		-65 to +150	°C

**RECOMMENDED OPERATING CONDITIONS**

SYMBOL	PARAMETER	LIMITS			UNIT
		MIN	NOM	MAX	
V <sub>CC</sub>	Supply voltage	4.5	5.0	5.5	V
V <sub>IN</sub>	High-level input voltage	2.0			V
V <sub>IL</sub>	Low-level input voltage			0.8	V
I <sub>Ik</sub>	Input clamp current			-18	mA
I <sub>OH</sub>	High-level output current	IR, OR, UNCPOUT		-1	mA
		Data outputs		-3	mA
I <sub>OL</sub>	Low-level output current	IR, OR, UNCPOUT		20	mA
		Data outputs		24	mA
T <sub>amb</sub>	Operating free air temperature range	0		+70	°C

## 16 × 5 asynchronous FIFO (3-State)

74F225

**DC ELECTRICAL CHARACTERISTICS**

(Over recommended operating free-air temperature range unless otherwise noted.)

SYMBOL	PARAMETER		TEST CONDITIONS <sup>1</sup>		LIMITS			UNIT
					MIN	TYP <sup>2</sup>	MAX	
V <sub>OH</sub>	High-level output voltage	IR, OR, UNCPOUT	V <sub>CC</sub> = MIN, V <sub>IL</sub> = MAX	±10%V <sub>CC</sub>	2.5			V
			V <sub>IH</sub> = MIN, I <sub>OH</sub> = MAX	±5%V <sub>CC</sub>	2.7			V
		Data outputs	V <sub>CC</sub> = MIN, V <sub>IL</sub> = MAX	±10%V <sub>CC</sub>	2.4			V
			V <sub>IH</sub> = MIN, I <sub>OH</sub> = MAX	±5%V <sub>CC</sub>	2.7			V
V <sub>OL</sub>	Low-level output voltage		V <sub>CC</sub> = MIN, V <sub>IL</sub> = MAX	±10%V <sub>CC</sub>		0.35	0.50	V
			V <sub>IH</sub> = MIN, I <sub>OL</sub> = MAX	±5%V <sub>CC</sub>		0.35	0.50	V
V <sub>IK</sub>	Input clamp voltage		V <sub>CC</sub> = MIN, I <sub>I</sub> = I <sub>IK</sub>			-0.73	-1.2	V
I <sub>I</sub>	Input current at maximum input voltage		V <sub>CC</sub> = MAX, V <sub>I</sub> = 7.0V				100	μA
I <sub>IH</sub>	High-level input current		V <sub>CC</sub> = MAX, V <sub>I</sub> = 2.7V				20	μA
I <sub>IL</sub>	Low-level input current		V <sub>CC</sub> = MAX, V <sub>I</sub> = 0.5V				-20	μA
I <sub>OZH</sub>	Offset-output current, High-level voltage applied		V <sub>CC</sub> = MAX, V <sub>I</sub> = 2.7V				50	μA
I <sub>OZL</sub>	Offset-output current, Low-level voltage applied		V <sub>CC</sub> = MAX, V <sub>I</sub> = 0.5V				-50	μA
I <sub>OS</sub>	Short-circuit output current <sup>3</sup>		V <sub>CC</sub> = MAX			-60	-150	mA
I <sub>CC</sub>	Supply current (total)		V <sub>CC</sub> = MAX			65	95	mA

**NOTES:**

- For conditions shown as MIN or MAX, use the appropriate value specified under recommended operating conditions for the applicable type.
- All typical values are at V<sub>CC</sub> = 5V, T<sub>amb</sub> = 25°C.
- Not more than one output should be shorted at a time. For testing I<sub>OS</sub>, the use of High-speed test apparatus and/or sample-and-hold techniques are preferable in order to minimize internal heating and more accurately reflect operational values. Otherwise, prolonged shorting of a High output may raise the chip temperature well above normal and thereby cause invalid readings in other parameter tests. In any sequence of parameter tests, I<sub>OS</sub> tests should be performed last.

## 16 × 5 asynchronous FIFO (3-State)

74F225

## AC ELECTRICAL CHARACTERISTICS

SYMBOL	PARAMETER	TEST CONDITION	LIMITS					UNIT
			T <sub>amb</sub> = +25°C V <sub>CC</sub> = +5.0V C <sub>L</sub> = 50pF, R <sub>L</sub> = 500Ω			T <sub>amb</sub> = 0°C to +70°C V <sub>CC</sub> = +5.0V ± 10% C <sub>L</sub> = 50pF, R <sub>L</sub> = 500Ω		
			MIN	TYP	MAX	MIN	MAX	
f <sub>MAX</sub>	Maximum clock frequency, Cascade mode	Waveform 2 and 3	25			25		MHz
t <sub>PLH</sub> t <sub>PHL</sub>	Propagation delay UNCPIN to Qn	Waveform 2	10.0 9.5	13.0 12.0	19.5 16.0	9.0 8.5	22.0 19.0	ns
t <sub>PLH</sub> t <sub>PHL</sub>	Propagation delay UNCPIN to OR	Waveform 2	16.0 6.0	20.0 8.5	25.0 11.0	14.0 5.0	29.0 12.0	ns
t <sub>SK</sub>	Output skew Qn to OR ↑	Waveform 4	2.0		12.0	0.0	15.0	ns
t <sub>PLH</sub>	Propagation delay UNCPIN to IR	Waveform 2	50	60	70	50	85	ns
t <sub>PLH</sub>	Propagation delay CPA or CPB to OR	Waveform 4	55	65	75	50	90	ns
t <sub>PLH</sub> t <sub>PHL</sub>	Propagation delay CPA or CPB to UNCPOUT	Waveform 4	20.0 8.5	23.0 11.5	27.0 15.0	17.0 7.5	29.0 16.0	ns
t <sub>w(L)</sub>	Pulse width, Low UNCPOUT	Waveform 4		12.0				ns
t <sub>PHL</sub>	Propagation delay CPA or CPB to IR	Waveform 3	11.0	13.5	17.0	9.0	19.0	ns
t <sub>PHL</sub>	Propagation delay MR to OR	Waveform 3	5.5	8.5	11.5	5.0	13.0	ns
t <sub>PHL</sub>	Propagation delay MR to IR	Waveform 3	2.0	4.0	7.0	1.5	7.5	ns
t <sub>PZH</sub> t <sub>PZL</sub>	Output enable time to High or Low level	Waveform 5 Waveform 6	1.5 2.5	3.5 4.5	6.5 7.5	1.0 2.0	7.0 9.0	ns
t <sub>PHZ</sub> t <sub>PLZ</sub>	Output disable time from High or Low level	Waveform 5 Waveform 6	1.5 2.0	3.5 4.0	7.0 7.0	1.0 1.5	7.5 7.5	ns

## AC SETUP REQUIREMENTS

SYMBOL	PARAMETER	TEST CONDITION	LIMITS					UNIT
			T <sub>amb</sub> = +25°C V <sub>CC</sub> = +5.0V C <sub>L</sub> = 50pF, R <sub>L</sub> = 500Ω			T <sub>amb</sub> = 0°C to +70°C V <sub>CC</sub> = +5.0V ± 10% C <sub>L</sub> = 50pF, R <sub>L</sub> = 500Ω		
			MIN	TYP	MAX	MIN	MAX	
t <sub>s(H)</sub> t <sub>s(L)</sub>	Setup time, High or Low Dn to CPA or CPB	Waveform 1	0.0 0.0			0.0 0.0		ns
t <sub>h(H)</sub> t <sub>h(L)</sub>	Hold time, High or Low Dn to CPA or CPB	Waveform 1	14.0 12.5			16.5 14.0		ns
t <sub>rec</sub>	Recovery time MR to CPA or CPB	Waveform 1	0.0			0.0		ns
t <sub>w(H)</sub> t <sub>w(L)</sub>	CPA or CPB pulse width, High or Low	Waveform 1	6.5 3.0			8.5 3.5		ns
t <sub>w(L)</sub>	UNCPIN pulse width, High or Low	Waveform 2	24.0 3.5			28.0 4.0		ns
t <sub>w(L)</sub>	$\overline{\text{MR}}$ pulse width, Low	Waveform 1	3.5			4.5		ns

# 16 × 5 asynchronous FIFO (3-State)

74F225

## TYPICAL TIMING DIAGRAM

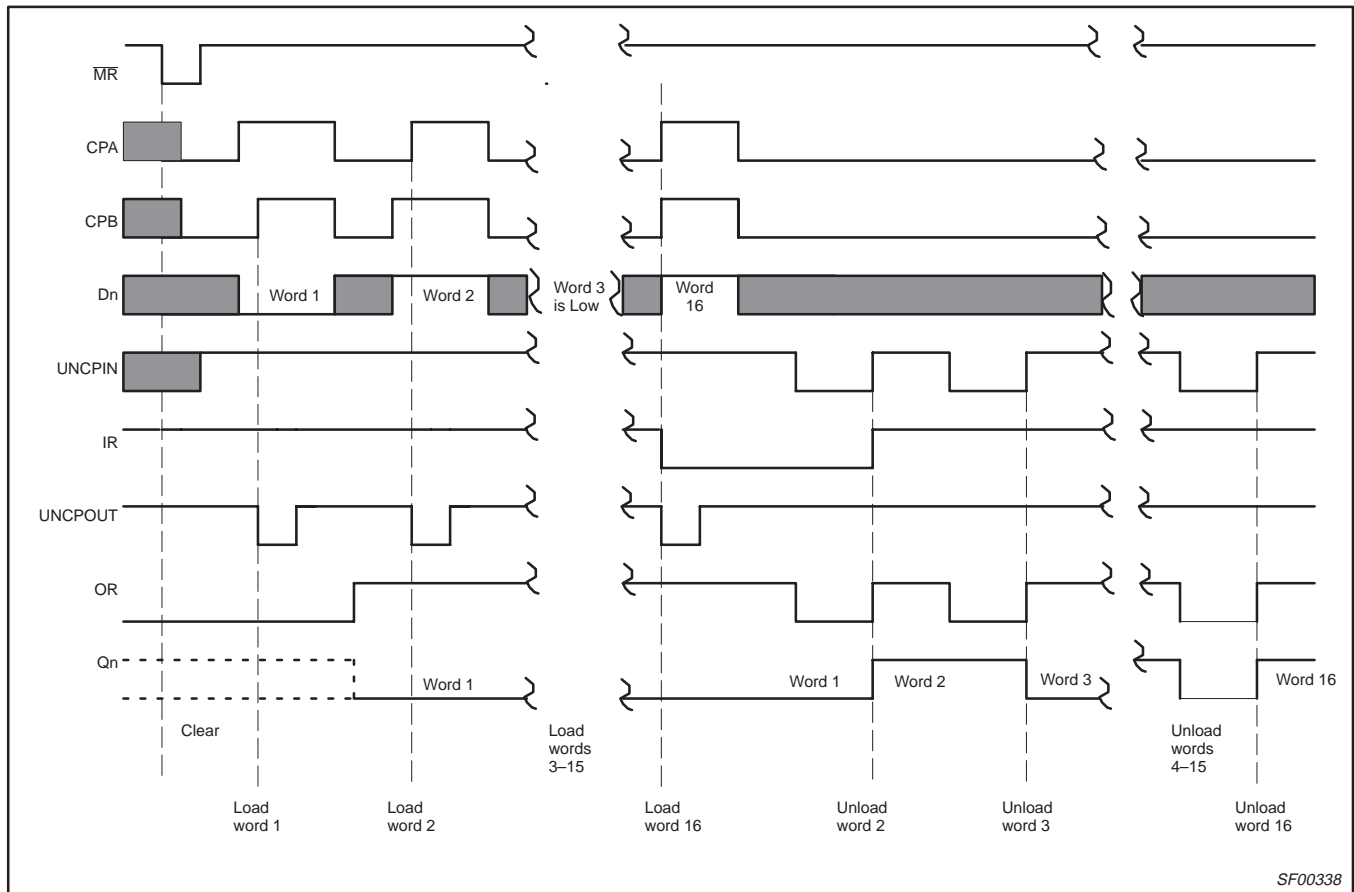

**NOTE:** Shaded areas Indicates irrelevant input conditions.

SF00338

# 16 × 5 asynchronous FIFO (3-State)

74F225

## AC WAVEFORMS

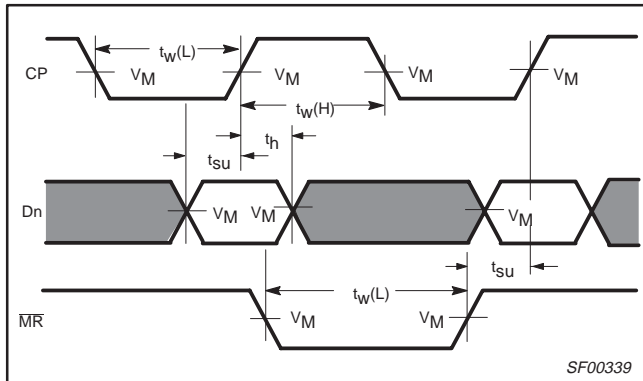

**Waveform 1. MR and Clock Pulse Widths, Data Setup and Hold Times and MR to Clock Setup Time**

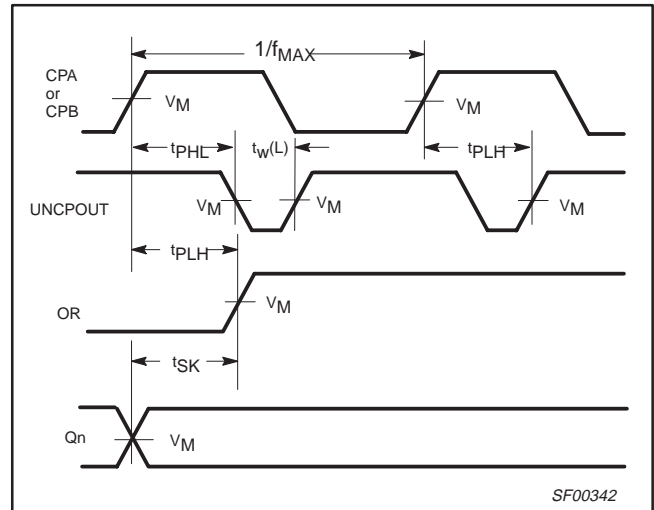

**Waveform 4. CPA or CPB to UNCPOUT and OR Delay, UNCPOUT Pulse Width and Qn to OR Skew**

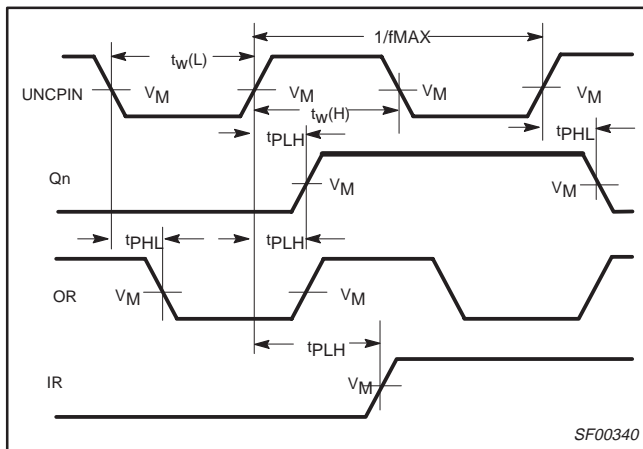

**Waveform 2. UNCPIN to Output Delays**

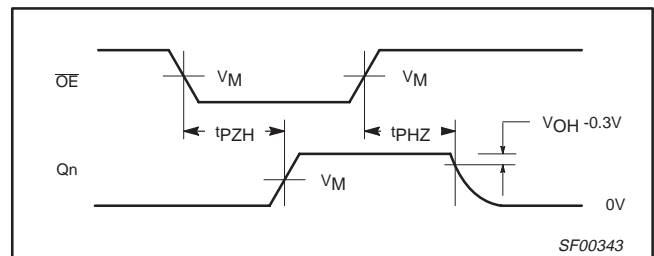

**Waveform 5. 3-State Output Enable Time to High Level and Output Disable Time from High Level**

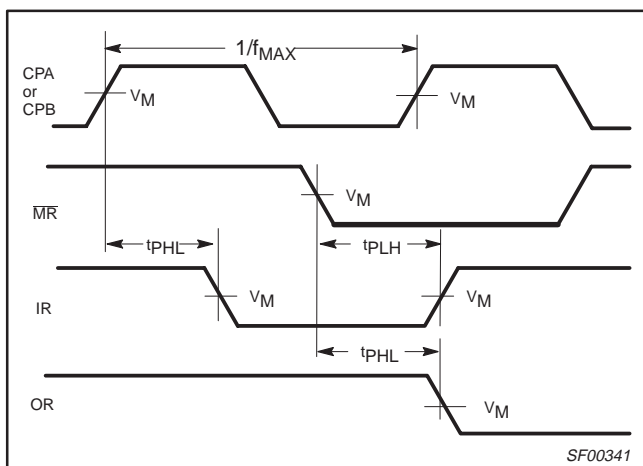

**Waveform 3. CPA or CPB to IR Delay and MR to IR and OR Delay**

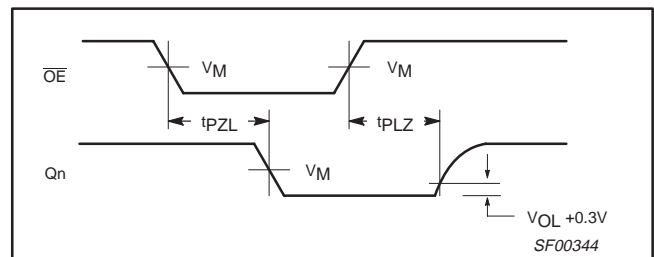

**Waveform 6. 3-State Output Enable Time to Low Level and Output Disable Time from Low Level**

**NOTES:**

1. For all waveforms,  $V_M = 1.5V$ .
2. The shaded areas indicate when the input is permitted to change for predictable output performance.

# 16 × 5 asynchronous FIFO (3-State)

74F225

## APPLICATION

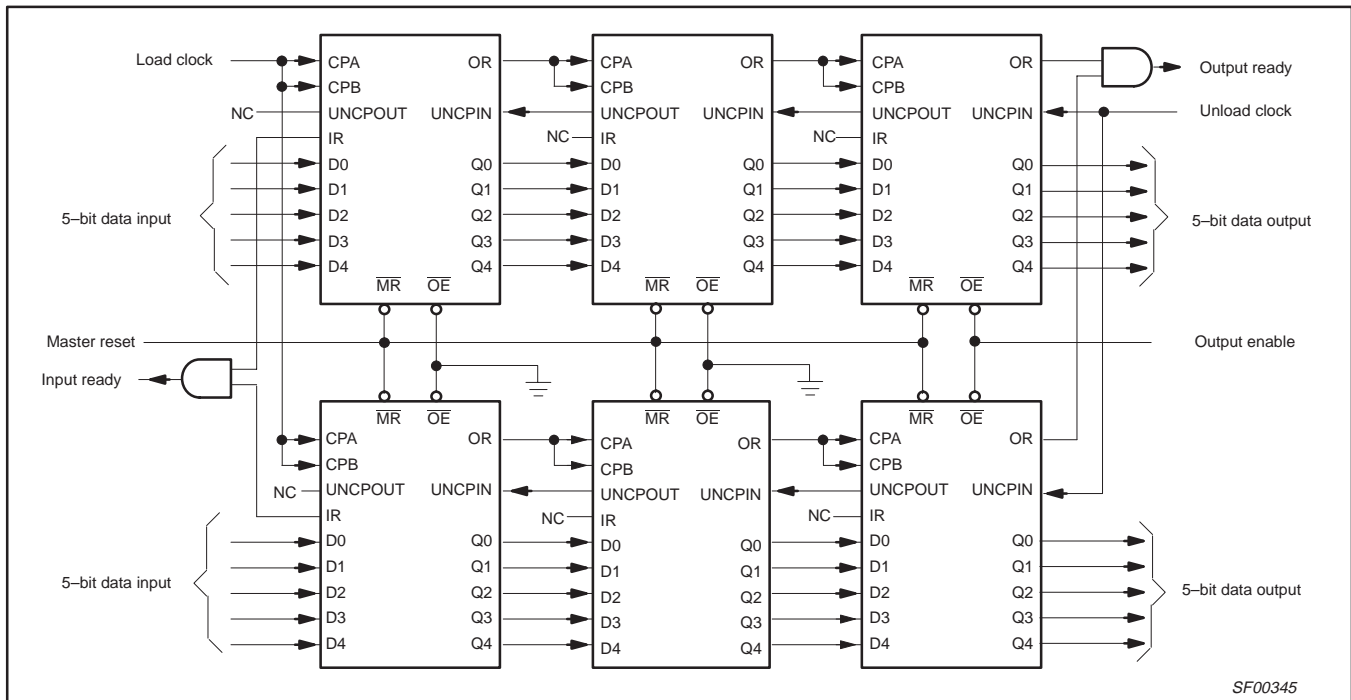

Figure 1. Expanding the 74F225 FIFO (48 words of 10 bits)

## TEST CIRCUIT AND WAVEFORM

**Test Circuit for Open Collector Outputs**

**SWITCH POSITION**

TEST	SWITCH
t <sub>PLZ</sub>	closed
t <sub>PZL</sub>	closed
All other	open

**DEFINITIONS:**  
 R<sub>L</sub> = Load resistor; see AC electrical characteristics for value.  
 C<sub>L</sub> = Load capacitance includes jig and probe capacitance; see AC electrical characteristics for value.  
 R<sub>T</sub> = Termination resistance should be equal to Z<sub>OUT</sub> of pulse generators.

**Input Pulse Definition**

INPUT PULSE REQUIREMENTS						
family	amplitude	V <sub>M</sub>	rep. rate	t <sub>w</sub>	t <sub>TLH</sub>	t <sub>THL</sub>
74F	3.0V	1.5V	1MHz	500ns	2.5ns	2.5ns

SF00128

# 16X5 asynchronous FIFO (3-State)

74F225

DIP20: plastic dual in-line package; 20 leads (300 mil)

SOT146-1

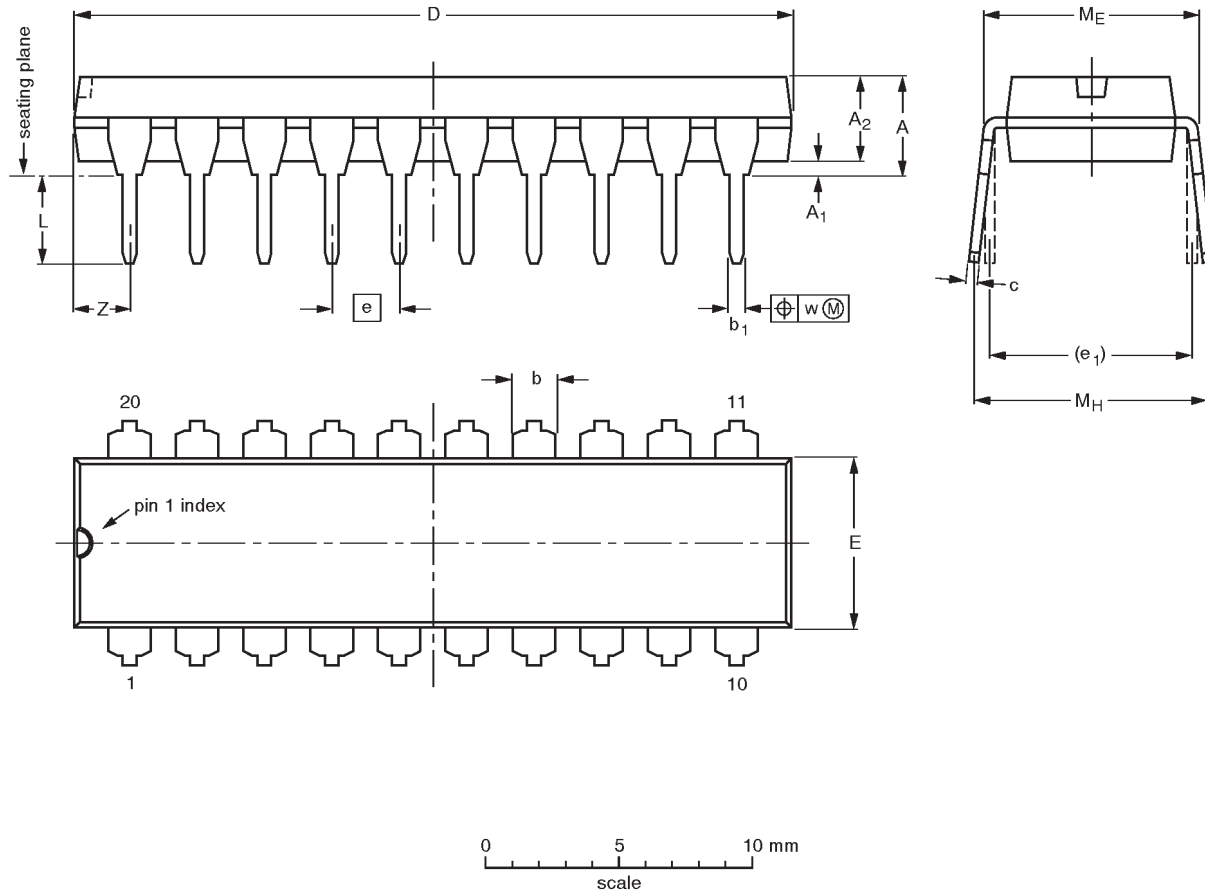

**DIMENSIONS** (inch dimensions are derived from the original mm dimensions)

UNIT	A max.	A <sub>1</sub> min.	A <sub>2</sub> max.	b	b <sub>1</sub>	c	D <sup>(1)</sup>	E <sup>(1)</sup>	e	e <sub>1</sub>	L	M <sub>E</sub>	M <sub>H</sub>	w	Z <sup>(1)</sup> max.
mm	4.2	0.51	3.2	1.73 1.30	0.53 0.38	0.36 0.23	26.92 26.54	6.40 6.22	2.54	7.62	3.60 3.05	8.25 7.80	10.0 8.3	0.254	2.0
inches	0.17	0.020	0.13	0.068 0.051	0.021 0.015	0.014 0.009	1.060 1.045	0.25 0.24	0.10	0.30	0.14 0.12	0.32 0.31	0.39 0.33	0.01	0.078

**Note**

1. Plastic or metal protrusions of 0.25 mm maximum per side are not included.

OUTLINE VERSION	REFERENCES				EUROPEAN PROJECTION	ISSUE DATE
	IEC	JEDEC	EIAJ			
SOT146-1			SC603			92-11-17 95-05-24

# 16X5 asynchronous FIFO (3-State)

## 74F225

**SO20:** plastic small outline package; 20 leads; body width 7.5 mm

**SOT163-1**

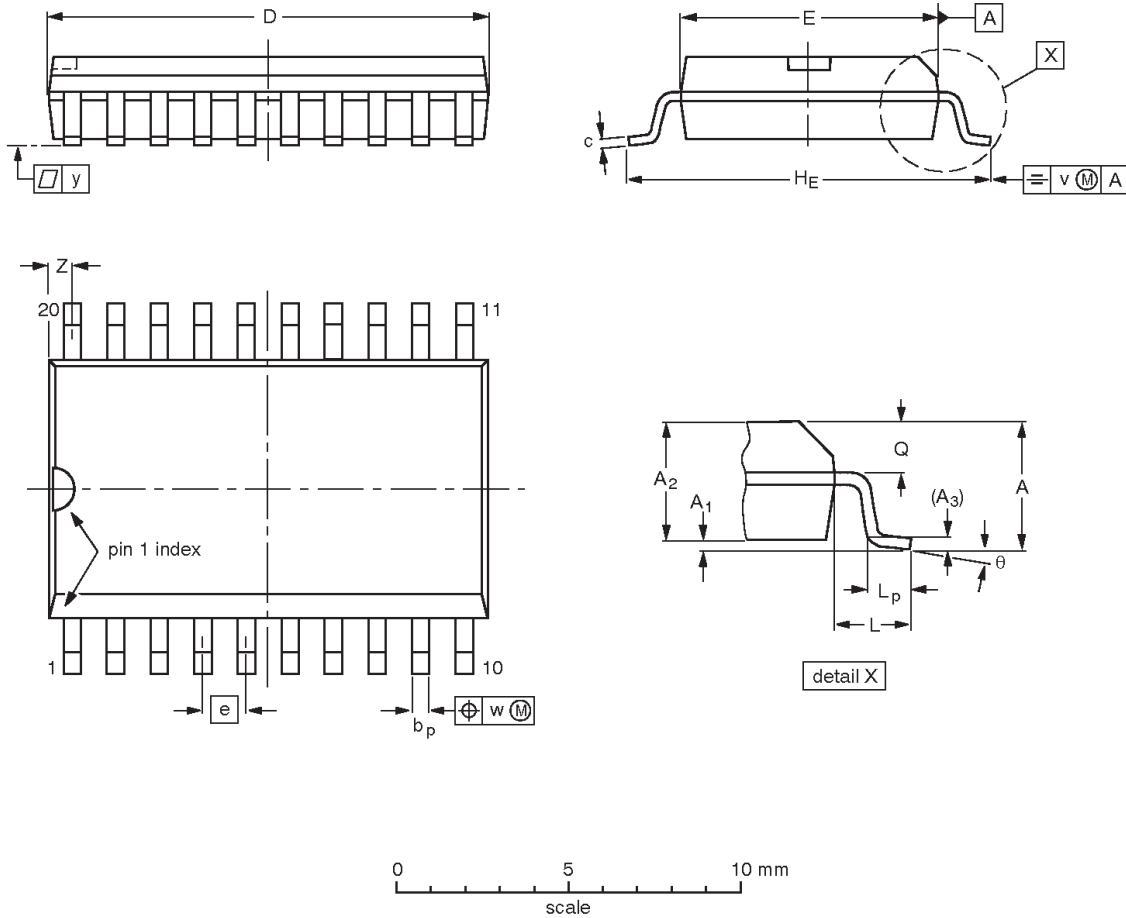

**DIMENSIONS (inch dimensions are derived from the original mm dimensions)**

UNIT	A max.	A <sub>1</sub>	A <sub>2</sub>	A <sub>3</sub>	b <sub>p</sub>	c	D <sup>(1)</sup>	E <sup>(1)</sup>	e	H <sub>E</sub>	L	L <sub>p</sub>	Q	v	w	y	Z <sup>(1)</sup>	θ
mm	2.65	0.30 0.10	2.45 2.25	0.25	0.49 0.36	0.32 0.23	13.0 12.6	7.6 7.4	1.27	10.65 10.00	1.4	1.1 0.4	1.1 1.0	0.25	0.25	0.1	0.9 0.4	8° 0°
inches	0.10	0.012 0.004	0.096 0.089	0.01	0.019 0.014	0.013 0.009	0.51 0.49	0.30 0.29	0.050	0.419 0.394	0.055	0.043 0.016	0.043 0.039	0.01	0.01	0.004	0.035 0.016	

**Note**

1. Plastic or metal protrusions of 0.15 mm maximum per side are not included.

OUTLINE VERSION	REFERENCES				EUROPEAN PROJECTION	ISSUE DATE
	IEC	JEDEC	EIAJ			
SOT163-1	075E04	MS-013AC				95-01-24 97-05-22

---

16X5 asynchronous FIFO (3-State)

74F225

---

**NOTES**

## 16X5 asynchronous FIFO (3-State)

74F225

**Data sheet status**

Data sheet status	Product status	Definition [1]
Objective specification	Development	This data sheet contains the design target or goal specifications for product development. Specification may change in any manner without notice.
Preliminary specification	Qualification	This data sheet contains preliminary data, and supplementary data will be published at a later date. Philips Semiconductors reserves the right to make changes at any time without notice in order to improve design and supply the best possible product.
Product specification	Production	This data sheet contains final specifications. Philips Semiconductors reserves the right to make changes at any time without notice in order to improve design and supply the best possible product.

[1] Please consult the most recently issued datasheet before initiating or completing a design.

**Definitions**

**Short-form specification** — The data in a short-form specification is extracted from a full data sheet with the same type number and title. For detailed information see the relevant data sheet or data handbook.

**Limiting values definition** — Limiting values given are in accordance with the Absolute Maximum Rating System (IEC 134). Stress above one or more of the limiting values may cause permanent damage to the device. These are stress ratings only and operation of the device at these or at any other conditions above those given in the Characteristics sections of the specification is not implied. Exposure to limiting values for extended periods may affect device reliability.

**Application information** — Applications that are described herein for any of these products are for illustrative purposes only. Philips Semiconductors make no representation or warranty that such applications will be suitable for the specified use without further testing or modification.

**Disclaimers**

**Life support** — These products are not designed for use in life support appliances, devices or systems where malfunction of these products can reasonably be expected to result in personal injury. Philips Semiconductors customers using or selling these products for use in such applications do so at their own risk and agree to fully indemnify Philips Semiconductors for any damages resulting from such application.

**Right to make changes** — Philips Semiconductors reserves the right to make changes, without notice, in the products, including circuits, standard cells, and/or software, described or contained herein in order to improve design and/or performance. Philips Semiconductors assumes no responsibility or liability for the use of any of these products, conveys no license or title under any patent, copyright, or mask work right to these products, and makes no representations or warranties that these products are free from patent, copyright, or mask work right infringement, unless otherwise specified.

Philips Semiconductors  
811 East Arques Avenue  
P.O. Box 3409  
Sunnyvale, California 94088-3409  
Telephone 800-234-7381

© Copyright Philips Electronics North America Corporation 1998  
All rights reserved. Printed in U.S.A.

print code

Date of release: 10-98

Document order number:

9397-750-05099

*Let's make things better.*



LittleDiode supplies new, hard to find or obsolete electronic components and semiconductors all over the world.

With over two million different components listed you are sure to find the part you need.

Feel free to visit us today at our online store:

[LittleDiode.com](http://LittleDiode.com)

Looking forward to providing you with the best possible service.