

DATA SHEET

For a complete data sheet, please also download:

- The IC06 74HC/HCT/HCU/HCMOS Logic Family Specifications
- The IC06 74HC/HCT/HCU/HCMOS Logic Package Information
- The IC06 74HC/HCT/HCU/HCMOS Logic Package Outlines

74HC/HCT93 4-bit binary ripple counter

Product specification
File under Integrated Circuits, IC06

December 1990

4-bit binary ripple counter

74HC/HCT93

FEATURES

- Various counting modes
- Asynchronous master reset
- Output capability: standard
- I_{CC} category: MSI

GENERAL DESCRIPTION

The 74HC/HCT93 are high-speed Si-gate CMOS devices and are pin compatible with low power Schottky TTL (LSTTL). They are specified in compliance with JEDEC standard no. 7A.

The 74HC/HCT93 are 4-bit binary ripple counters. The devices consist of four master-slave flip-flops internally connected to provide a

divide-by-two section and a divide-by-eight section. Each section has a separate clock input (\overline{CP}_0 and \overline{CP}_1) to initiate state changes of the counter on the HIGH-to-LOW clock transition. State changes of the Q_n outputs do not occur simultaneously because of internal ripple delays. Therefore, decoded output signals are subject to decoding spikes and should not be used for clocks or strobes.

A gated AND asynchronous master reset (MR₁ and MR₂) is provided which overrides both clocks and resets (clears) all flip-flops.

Since the output from the divide-by-two section is not internally connected to the succeeding stages,

the device may be operated in various counting modes. In a 4-bit ripple counter the output Q₀ must be connected externally to input \overline{CP}_1 . The input count pulses are applied to clock input \overline{CP}_0 . Simultaneous frequency divisions of 2, 4, 8 and 16 are performed at the Q₀, Q₁, Q₂ and Q₃ outputs as shown in the function table. As a 3-bit ripple counter the input count pulses are applied to input \overline{CP}_1 . Simultaneous frequency divisions of 2, 4 and 8 are available at the Q₁, Q₂ and Q₃ outputs. Independent use of the first flip-flop is available if the reset function coincides with reset of the 3-bit ripple-through counter.

QUICK REFERENCE DATA

GND = 0 V; T_{amb} = 25 °C; t_r = t_f = 6 ns

SYMBOL	PARAMETER	CONDITIONS	TYPICAL		UNIT
			HC	HCT	
t _{PHL} / t _{PLH}	propagation delay \overline{CP}_0 to Q ₀	C _L = 15 pF; V _{CC} = 5 V	12	15	ns
f _{max}	maximum clock frequency		100	77	MHz
C _I	input capacitance		3.5	3.5	pF
C _{PD}	power dissipation capacitance per package	notes 1 and 2	22	22	pF

Notes

1. C_{PD} is used to determine the dynamic power dissipation (P_D in μW):

$$P_D = C_{PD} \times V_{CC}^2 \times f_i + \sum (C_L \times V_{CC}^2 \times f_o) \text{ where:}$$

f_i = input frequency in MHz; f_o = output frequency in MHz

∑ (C_L × V_{CC}² × f_o) = sum of outputs

C_L = output load capacitance in pF; V_{CC} = supply voltage in V

2. For HC the condition is V_I = GND to V_{CC}; for HCT the condition is V_I = GND to V_{CC} – 1.5 V

ORDERING INFORMATION

See "74HC/HCT/HCU/HCMOS Logic Package Information".

4-bit binary ripple counter

74HC/HCT93

PIN DESCRIPTION

PIN NO.	SYMBOL	NAME AND FUNCTION
1	\overline{CP}_1	clock input 2 nd , 3 rd and 4 th section (HIGH-to-LOW, edge-triggered)
2, 3	MR ₁ , MR ₂	asynchronous master reset (active HIGH)
4, 6, 7, 13	n.c.	not connected
5	V _{CC}	positive supply voltage
10	GND	ground (0 V)
12, 9, 8, 11	Q ₀ to Q ₃	flip-flop outputs
14	\overline{CP}_0	clock input 1 st section (HIGH-to-LOW, edge-triggered)

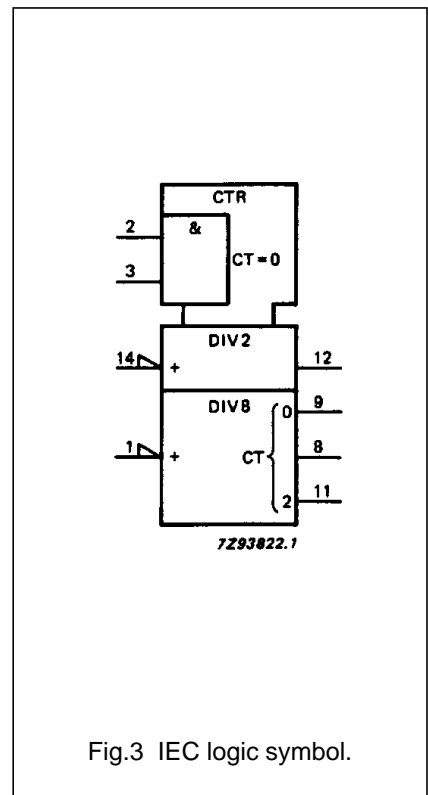
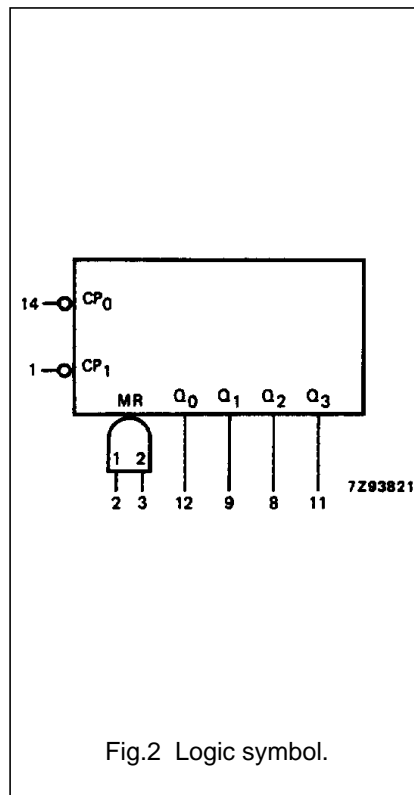
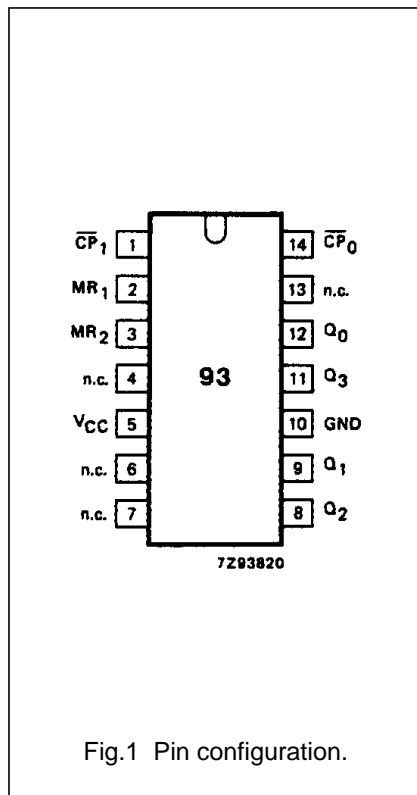

4-bit binary ripple counter

74HC/HCT93

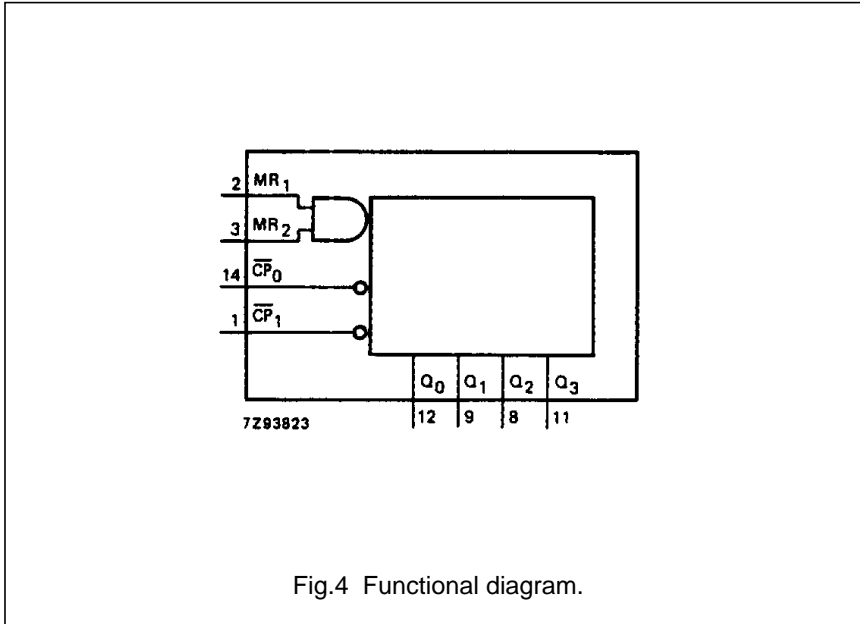

Fig.4 Functional diagram.

FUNCTION TABLE

COUNT	OUTPUTS			
	Q ₀	Q ₁	Q ₂	Q ₃
0	L	L	L	L
1	H	L	L	L
2	L	H	L	L
3	H	H	L	L
4	L	L	H	L
5	H	L	H	L
6	L	H	H	L
7	H	H	H	L
8	L	L	L	H
9	H	L	L	H
10	L	H	L	H
11	H	H	L	H
12	L	L	H	H
13	H	L	H	H
14	L	H	H	H
15	H	H	H	H

Notes

- Output Q₀ connected to $\overline{CP_1}$.
 H = HIGH voltage level
 L = LOW voltage level

MODE SELECTION

RESET INPUTS		OUTPUTS			
MR ₁	MR ₂	Q ₀	Q ₁	Q ₂	Q ₃
H	H	L	L	L	L
L	H	count			
H	L	count			
L	L	count			

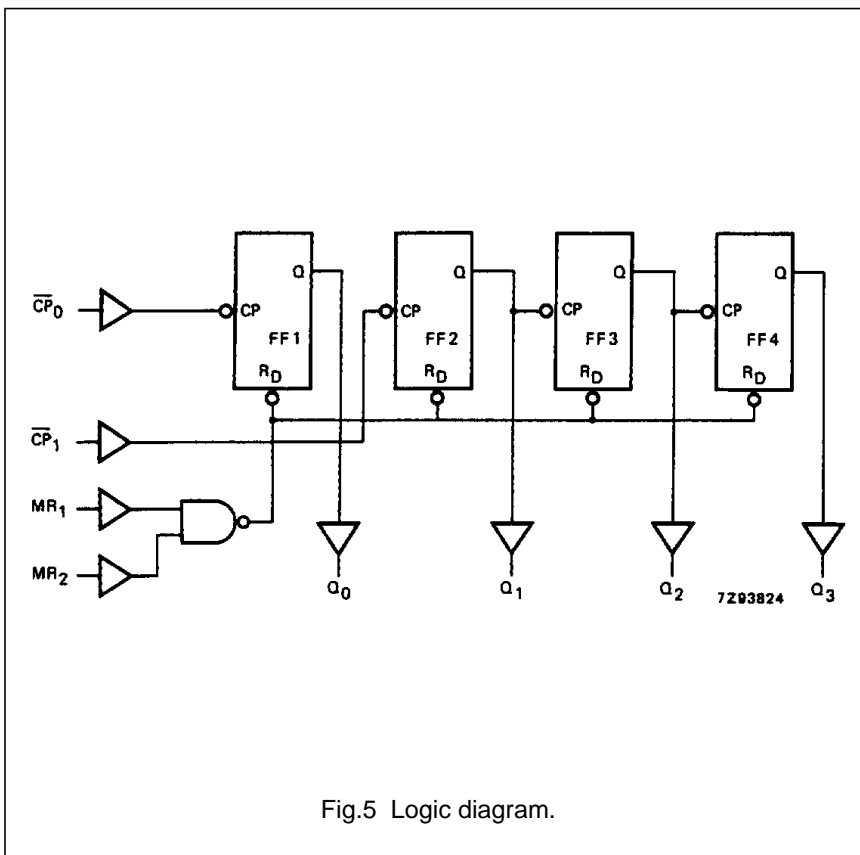

Fig.5 Logic diagram.

4-bit binary ripple counter

74HC/HCT93

DC CHARACTERISTICS FOR 74HC

For the DC characteristics see *"74HC/HCT/HCU/HCMOS Logic Family Specifications"*.

Output capability: standard

I_{CC} category: MSI

AC CHARACTERISTICS FOR 74HC

GND = 0 V; t_r = t_f = 6 ns; C_L = 50 pF

SYMBOL	PARAMETER	T _{amb} (°C)							UNIT	TEST CONDITIONS	
		74HC								V _{CC} (V)	WAVEFORMS
		+25			-40 to +85		-40 to +125				
		min.	typ.	max.	min.	max.	min.	max.			
t _{PHL} / t _{PLH}	propagation delay CP ₀ to Q ₀		41 15 12	125 25 21		155 31 26		190 38 32	ns	2.0 4.5 6.0	Fig.6
t _{PHL} / t _{PLH}	propagation delay CP ₁ to Q ₁		49 16 13	135 27 23		170 34 29		205 41 35	ns	2.0 4.5 6.0	Fig.6
t _{PHL} / t _{PLH}	propagation delay CP ₁ to Q ₂		61 22 18	185 37 31		230 46 39		280 56 48	ns	2.0 4.5 6.0	Fig.6
t _{PHL} / t _{PLH}	propagation delay CP ₁ to Q ₃		80 29 23	245 49 42		305 61 52		370 71 63	ns	2.0 4.5 6.0	Fig.6
t _{PHL}	propagation delay MR _n to Q _n		50 18 14	155 31 26		195 39 33		235 47 40	ns	2.0 4.5 6.0	Fig.7
t _{THL} / t _{TLH}	output transition time		19 7 6	75 15 13		95 19 16		110 22 19	ns	2.0 4.5 6.0	Fig.6
t _{rem}	removal time MR _n to CP ₀ , CP ₁	50 10 9	8 3 2		65 13 11		75 15 13		ns	2.0 4.5 6.0	Fig.7
t _w	pulse width CP ₀ , CP ₁	80 16 14	14 5 4		100 20 17		120 24 20		ns	2.0 4.5 6.0	Fig.6
t _w	master reset pulse width MR _n	80 16 14	14 5 4		100 20 17		120 24 20		ns	2.0 4.5 6.0	Fig.7
f _{max}	maximum clock pulse frequency CP ₀ , CP ₁	6.0 30 35	30 91 108		4.8 24 28		4.0 20 24		MHz	2.0 4.5 6.0	Fig.6

4-bit binary ripple counter

74HC/HCT93

DC CHARACTERISTICS FOR 74HCT

For the DC characteristics see *"74HC/HCT/HCU/HCMOS Logic Family Specifications"*.

Output capability: standard

I_{CC} category: MSI

Note to HCT types

The value of additional quiescent supply current (ΔI_{CC}) for a unit load of 1 is given in the family specifications. To determine ΔI_{CC} per input, multiply this value by the unit load coefficient shown in the table below.

INPUT	UNIT LOAD COEFFICIENT
$\overline{CP}_0, \overline{CP}_1$	0.60
MR_n	0.40

AC CHARACTERISTICS FOR 74HCT

GND = 0 V; $t_r = t_f = 6$ ns; $C_L = 50$ pF

SYMBOL	PARAMETER	T _{amb} (°C)							UNIT	TEST CONDITIONS	
		74HCT								V _{CC} (V)	WAVEFORMS
		+25			-40 to +85		-40 to +125				
		min.	typ.	max.	min.	max.	min.	max.			
t _{PHL} / t _{PLH}	propagation delay \overline{CP}_0 to Q ₀		18	34		43		51	ns	4.5	Fig.6
t _{PHL} / t _{PLH}	propagation delay CP ₁ to Q ₁		18	34		43		51	ns	4.5	Fig.6
t _{PHL} / t _{PLH}	propagation delay \overline{CP}_1 to Q ₂		24	46		58		69	ns	4.5	Fig.6
t _{PHL} / t _{PLH}	propagation delay \overline{CP}_1 to Q ₃		30	58		73		87	ns	4.5	Fig.6
t _{PHL}	propagation delay MR _n to Q _n		17	33		41		50	ns	4.5	Fig.7
t _{THL} / t _{TLH}	output transition time		7	15		19		22	ns	4.5	Fig.6
t _{rem}	removal time MR _n to $\overline{CP}_0, \overline{CP}_1$	10	3		13		15		ns	4.5	Fig.7
t _w	pulse width $\overline{CP}_0, \overline{CP}_1$	16	7		20		24		ns	4.5	Fig.6
t _w	master reset pulse width MR _n	16	5		20		24		ns	4.5	Fig.7
f _{max}	maximum clock pulse frequency $\overline{CP}_0, \overline{CP}_1$	30	70		24		20		MHz	4.5	Fig.6

4-bit binary ripple counter

74HC/HCT93

AC WAVEFORMS

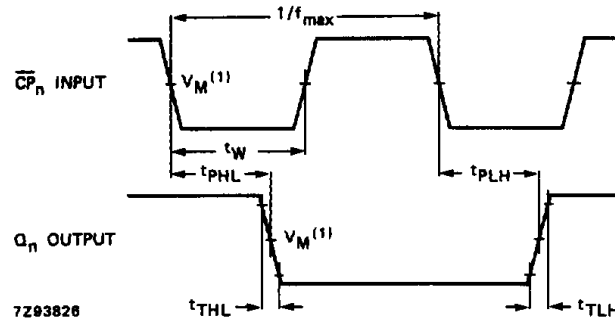

(1) HC : $V_M = 50\%$; $V_I = \text{GND to } V_{CC}$.
 HCT: $V_M = 1.3 \text{ V}$; $V_I = \text{GND to } 3 \text{ V}$.

Fig.6 Waveforms showing the clock (\overline{CP}_n) to output (Q_n) propagation delays, the clock pulse width, output transition times and the maximum clock pulse frequency.

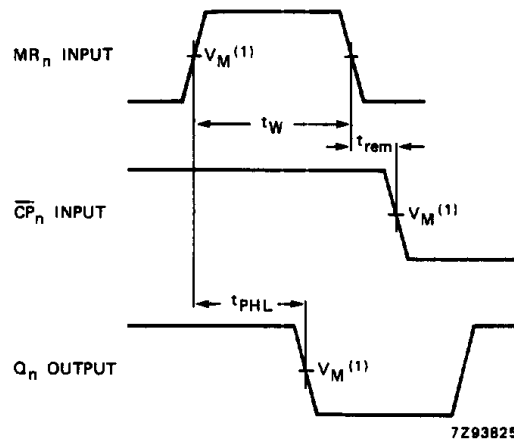

(1) HC : $V_M = 50\%$; $V_I = \text{GND to } V_{CC}$.
 HCT: $V_M = 1.3 \text{ V}$; $V_I = \text{GND to } 3 \text{ V}$.

Fig.7 Waveforms showing the master reset (MR_n) pulse width, the master reset to output (Q_n) propagation delays and the master reset to clock (\overline{CP}_n) removal time.

PACKAGE OUTLINES

See "74HC/HCT/HCU/HCMOS Logic Package Outlines".



LittleDiode supplies new, hard to find or obsolete electronic components and semiconductors all over the world.

With over two million different components listed you are sure to find the part you need.

Feel free to visit us today at our online store:

LittleDiode.com

Looking forward to providing you with the best possible service.