

## 54F/74F169 4-Stage Synchronous Bidirectional Counter

### General Description

The 'F169 is a fully synchronous 4-stage up/down counter. The 'F169 is a modulo-16 binary counter. Features a preset capability for programmable operation, carry lookahead for easy cascading and a U/D input to control the direction of counting. All state changes, whether in counting or parallel loading, are initiated by the LOW-to-HIGH transition of the clock.

### Features

- Asynchronous counting and loading
- Built-in lookahead carry capability
- Presetable for programmable operation

Commercial	Military	Package Number	Package Description
74F169PC		N16E	16-Lead (0.300" Wide) Molded Dual-In-Line
	54F169DM (Note 2)	J16A	16-Lead Ceramic Dual-In-Line
74F169SC (Note 1)		M16A	16-Lead (0.150" Wide) Molded Small Outline, JEDEC
74F169SJ (Note 1)		M16D	16-Lead (0.300" Wide) Molded Small Outline, EIAJ

**Note 1:** Devices also available in 13" reel. Use suffix = SCX and SJX.

**Note 2:** Military grade device with environmental and burn-in processing. Use suffix = DMQB.

### Logic Symbols

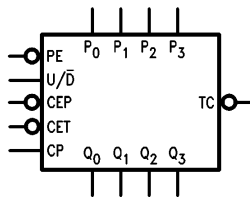

TL/F/9488-3

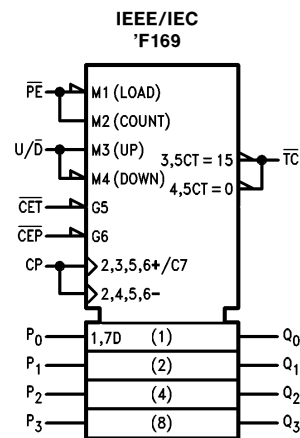

TL/F/9488-9

TRI-STATE® is a registered trademark of National Semiconductor Corporation.

## Connection Diagrams

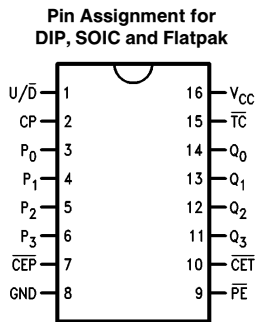

TL/F/9488-1

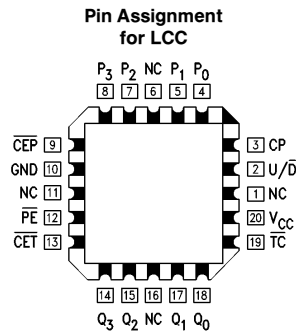

TL/F/9488-2

## Unit Loading/Fan Out

Pin Names	Description	54F/74F	
		U.L. HIGH/LOW	Input $I_{IH}/I_{IL}$ Output $I_{OH}/I_{OL}$
$\overline{CEP}$	Count Enable Parallel Input (Active LOW)	1.0/1.0	20 $\mu A$ / -0.6 mA
$\overline{CET}$	Count Enable Trickle Input (Active LOW)	1.0/2.0	20 $\mu A$ / -1.2 mA
CP	Clock Pulse Input (Active Rising Edge)	1.0/1.0	20 $\mu A$ / -0.6 mA
$P_0$ - $P_3$	Parallel Data Inputs	1.0/1.0	20 $\mu A$ / -0.6 mA
$\overline{PE}$	Parallel Enable Input (Active LOW)	1.0/1.0	20 $\mu A$ / -0.6 mA
$U/\overline{D}$	Up-Down Count Control Input	1.0/1.0	20 $\mu A$ / -0.6 mA
$Q_0$ - $Q_3$	Flip-Flop Outputs	50/33.3	-1 mA/20 mA
$\overline{TC}$	Terminal Count Output (Active LOW)	50/33.3	-1 mA/20 mA

## Functional Description

The 'F169 uses edge-triggered J-K type flip-flops and has no constraints on changing the control or data input signals in either state of the clock. The only requirement is that the various inputs attain the desired state at least a setup time before the rising edge of the clock and remain valid for the recommended hold time thereafter. The parallel load operation takes precedence over other operations, as indicated in the Mode Select Table. When  $\overline{PE}$  is LOW, the data on the  $P_0$ - $P_3$  inputs enters the flip-flops on the next rising edge of the clock. In order for counting to occur, both  $\overline{CEP}$  and  $\overline{CET}$  must be LOW and  $\overline{PE}$  must be HIGH; the  $U/\overline{D}$  input then determines the direction of counting. The Terminal Count ( $\overline{TC}$ ) output is normally HIGH and goes LOW, provided that

$\overline{CET}$  is LOW, when a counter reaches zero in the Count Down mode or reaches 15 for the 'F169 in the Count Up mode. The  $\overline{TC}$  output state is not a function of the Count Enable Parallel ( $\overline{CEP}$ ) input level. Since the  $\overline{TC}$  signal is derived by decoding the flip-flop states, there exists the possibility of decoding spikes on  $\overline{TC}$ . For this reason the use of  $\overline{TC}$  as a clock signal is not recommended (see logic equations below).

- 1) Count Enable =  $\overline{CEP} \bullet \overline{CET} \bullet \overline{PE}$
- 2) Up: ('F169):  $\overline{TC} = Q_0 \bullet Q_1 \bullet Q_2 \bullet Q_3 \bullet (\text{Up}) \bullet \overline{CET}$
- 3) Down:  $\overline{TC} = \overline{Q_0} \bullet \overline{Q_1} \bullet \overline{Q_2} \bullet \overline{Q_3} \bullet (\text{Down}) \bullet \overline{CET}$

## Logic Diagram

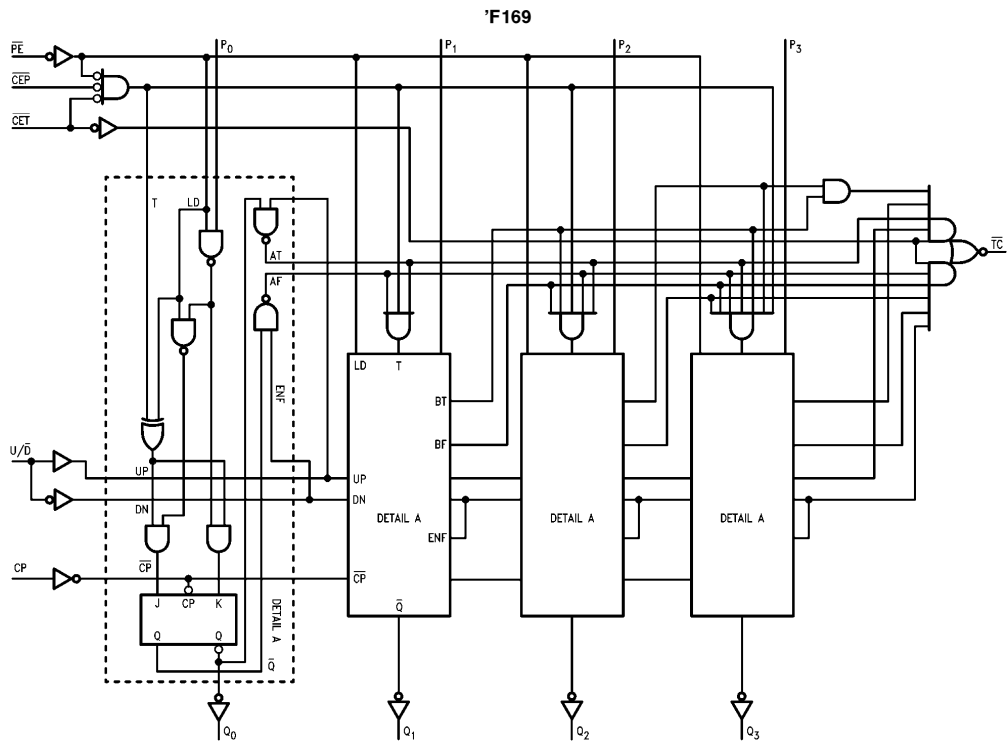

TL/F/9488-5

Please note that these diagrams are provided only for the understanding of logic operations and should not be used to estimate propagation delays.

Mode Select Table

PE	CEP	CET	U/D	Action on Rising Clock Edge
L	X	X	X	Load ( $P_n \rightarrow Q_n$ )
H	L	L	H	Count Up (Increment)
H	L	L	L	Count Down (Decrement)
H	H	X	X	No Change (Hold)
H	X	H	X	No Change (Hold)

H = HIGH Voltage Level  
L = LOW Voltage Level  
X = Immaterial

## State Diagram

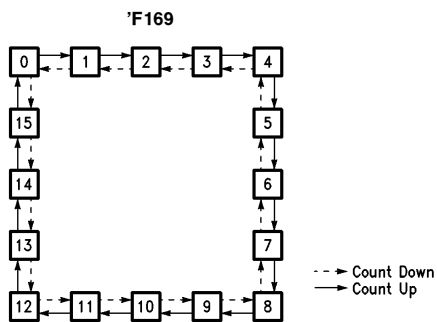

TL/F/9488-7

## Absolute Maximum Ratings (Note 1)

If Military/Aerospace specified devices are required, please contact the National Semiconductor Sales Office/Distributors for availability and specifications.

Storage Temperature	–65°C to +150°C
Ambient Temperature under Bias	–55°C to +125°C
Junction Temperature under Bias	–55°C to +175°C
Plastic	–55°C to +150°C

V<sub>CC</sub> Pin Potential to Ground Pin –0.5V to +7.0V

Input Voltage (Note 2) –0.5V to +7.0V

Input Current (Note 2) –30 mA to +5.0 mA

Voltage Applied to Output in HIGH State (with V<sub>CC</sub> = 0V)

Standard Output	–0.5V to V <sub>CC</sub>
TRI-STATE® Output	–0.5V to +5.5V

Current Applied to Output in LOW State (Max) twice the rated I<sub>OL</sub> (mA)

**Note 1:** Absolute maximum ratings are values beyond which the device may be damaged or have its useful life impaired. Functional operation under these conditions is not implied.

**Note 2:** Either voltage limit or current limit is sufficient to protect inputs.

## Recommended Operating Conditions

Free Air Ambient Temperature	
Military	–55°C to +125°C
Commercial	0°C to +70°C
Supply Voltage	
Military	+4.5V to +5.5V
Commercial	+4.5V to +5.5V

## DC Electrical Characteristics

Symbol	Parameter		54F/74F			Units	V <sub>CC</sub>	Conditions
			Min	Typ	Max			
V <sub>IH</sub>	Input HIGH Voltage		2.0			V		Recognized as a HIGH Signal
V <sub>IL</sub>	Input LOW Voltage					V		Recognized as a LOW Signal
V <sub>CD</sub>	Input Clamp Diode Voltage					V	Min	I <sub>IN</sub> = –18 mA
V <sub>OH</sub>	Output HIGH Voltage	54F 10% V <sub>CC</sub> 74F 10% V <sub>CC</sub> 74F 5% V <sub>CC</sub>	2.5 2.5 2.7			V	Min	I <sub>OH</sub> = –1 mA I <sub>OH</sub> = –1 mA I <sub>OH</sub> = –1 mA
V <sub>OL</sub>	Output LOW Voltage	54F 10% V <sub>CC</sub> 74F 10% V <sub>CC</sub>	0.5 0.5			V	Min	I <sub>OL</sub> = 20 mA I <sub>OL</sub> = 20 mA
I <sub>IH</sub>	Input HIGH Current	54F 74F	20.0 5.0			μA	Max	V <sub>IN</sub> = 2.7V
I <sub>BVI</sub>	Input HIGH Current Breakdown Test	54F 74F	100 7.0			μA	Max	V <sub>IN</sub> = 7.0V
I <sub>CEX</sub>	Output HIGH Leakage Current	54F 74F	250 50			μA	Max	V <sub>OUT</sub> = V <sub>CC</sub>
V <sub>ID</sub>	Input Leakage Test	74F	4.75			V	0.0	I <sub>ID</sub> = 1.9 μA All Other Pins Grounded
I <sub>OD</sub>	Output Leakage Circuit Current	74F	3.75			μA	0.0	V <sub>IOD</sub> = 150 mV All Other Pins Grounded
I <sub>IL</sub>	Input LOW Current		–0.6 –1.2			mA	Max	V <sub>IN</sub> = 0.5V (except $\overline{CET}$ ) V <sub>IN</sub> = 0.5V ( $\overline{CET}$ )
I <sub>OS</sub>	Output Short-Circuit Current		–60 –150			mA	Max	V <sub>OUT</sub> = 0V
I <sub>CCL</sub>	Power Supply Current		35 52			mA	Max	V <sub>O</sub> = LOW

'F169

**AC Electrical Characteristics**

Symbol	Parameter	74F			54F		74F		Units
		T <sub>A</sub> = +25°C V <sub>CC</sub> = +5.0V C <sub>L</sub> = 50 pF			T <sub>A</sub> , V <sub>CC</sub> = Mil C <sub>L</sub> = 50 pF		T <sub>A</sub> , V <sub>CC</sub> = Com C <sub>L</sub> = 50 pF		
		Min	Typ	Max	Min	Max	Min	Max	
f <sub>max</sub>	Maximum Count Frequency	90			60		70		MHz
t <sub>PLH</sub> t <sub>PHL</sub>	Propagation Delay CP to Q <sub>n</sub> ( $\overline{PE}$ HIGH or LOW)	3.0 4.0	6.5 9.0	8.5 11.5	3.0 4.0	12.0 16.0	3.0 4.0	9.5 13.0	ns
t <sub>PLH</sub> t <sub>PHL</sub>	Propagation Delay CP to $\overline{TC}$	5.5 4.0	12.0 8.5	15.5 12.5	5.5 4.0	20.0 15.0	5.5 4.0	17.5 13.0	ns
t <sub>PLH</sub> t <sub>PHL</sub>	Propagation Delay $\overline{CET}$ to $\overline{TC}$	2.5 2.5	4.5 8.5	6.5 11.0	2.5 2.5	9.0 12.0	2.5 2.5	7.0 12.0	ns
t <sub>PLH</sub> t <sub>PHL</sub>	Propagation Delay U/ $\overline{D}$ to $\overline{TC}$	3.5 4.0	8.5 8.0	11.5 12.0	3.5 4.0	16.0 14.0	3.5 4.0	12.5 13.0	ns

**AC Operating Requirements**

Symbol	Parameter	74F		54F		74F		Units
		T <sub>A</sub> = +25°C V <sub>CC</sub> = +5.0V		T <sub>A</sub> , V <sub>CC</sub> = Mil		T <sub>A</sub> , V <sub>CC</sub> = Com		
		Min	Max	Min	Max	Min	Max	
t <sub>s</sub> (H) t <sub>s</sub> (L)	Setup Time, HIGH or LOW P <sub>n</sub> to CP	4.0 4.0		4.5 4.5		4.5 4.5		ns
t <sub>h</sub> (H) t <sub>h</sub> (L)	Hold Time, HIGH or LOW P <sub>n</sub> to CP	3.0 3.0		3.5 3.5		3.5 3.5		ns
t <sub>s</sub> (H) t <sub>s</sub> (L)	Setup Time, HIGH or LOW $\overline{CEP}$ or $\overline{CET}$ to CP	7.0 5.0		8.0 8.0		8.0 6.5		ns
t <sub>h</sub> (H) t <sub>h</sub> (L)	Hold Time, HIGH or LOW $\overline{CEP}$ or $\overline{CET}$ to CP	0 0.5		0 1.0		0 0.5		ns
t <sub>s</sub> (H) t <sub>s</sub> (L)	Setup Time, HIGH or LOW $\overline{PE}$ to CP	8.0 8.0		10.0 10.0		9.0 9.0		ns
t <sub>h</sub> (H) t <sub>h</sub> (L)	Hold Time, HIGH or LOW $\overline{PE}$ to CP	1.0 0		1.0 0		1.0 0		ns
t <sub>s</sub> (H) t <sub>s</sub> (L)	Setup Time, HIGH or LOW U/ $\overline{D}$ to CP	11.0 7.0		14.0 12.0		12.5 8.5		ns
t <sub>h</sub> (H) t <sub>h</sub> (L)	Hold Time, HIGH or LOW U/ $\overline{D}$ to CP	0 0		0 0		0 0		ns
t <sub>w</sub> (H) t <sub>w</sub> (L)	CP Pulse Width HIGH or LOW	4.0 7.0		6.0 9.0		4.5 8.0		ns

## Ordering Information

The device number is used to form part of a simplified purchasing code where the package type and temperature range are defined as follows:

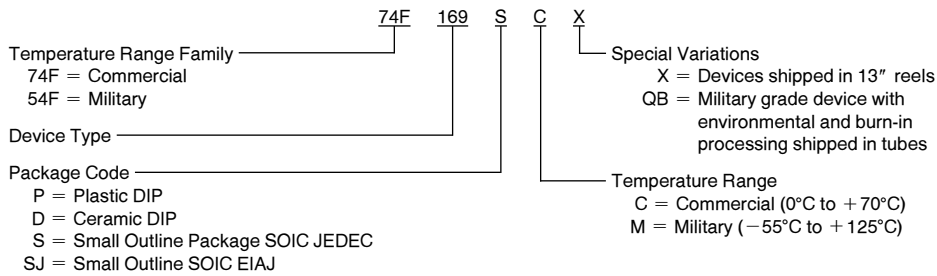

## Physical Dimensions inches (millimeters)

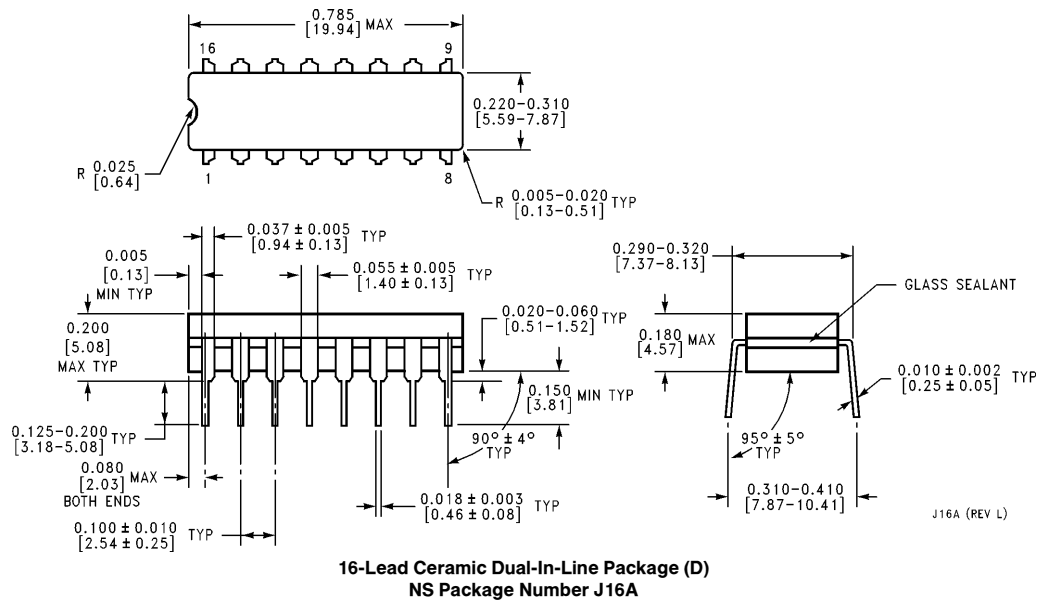

**Physical Dimensions** inches (millimeters) (Continued)

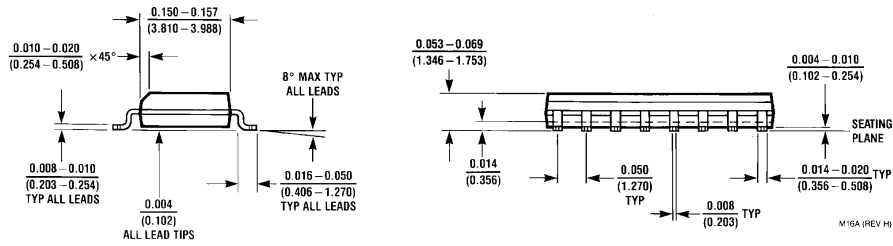
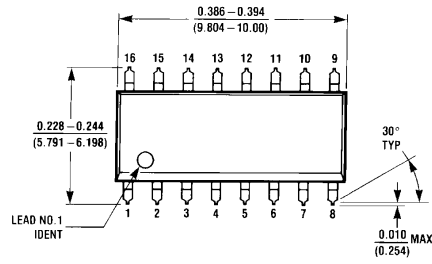

**16-Lead (0.150" Wide) Molded Small Outline Package, JEDEC (S)  
NS Package Number M16A**

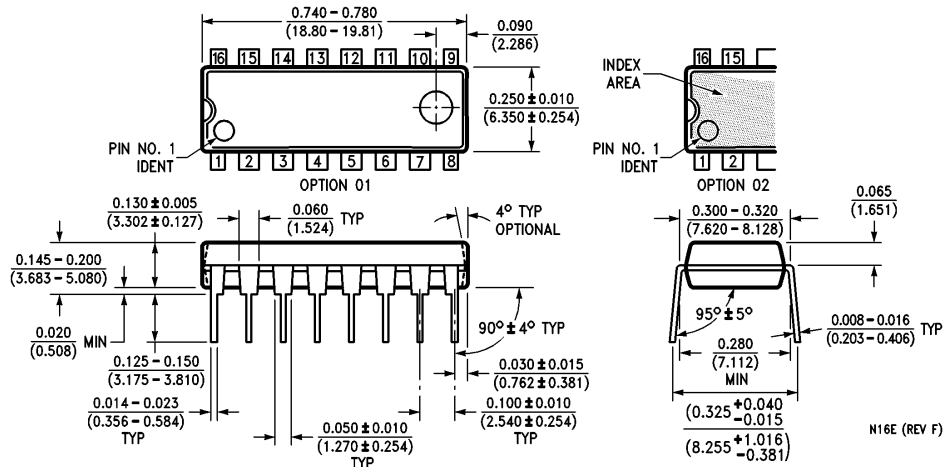

**16-Lead (0.300" Wide) Molded Dual-In-Line Package (P)  
NS Package Number N16E**

**Physical Dimensions** inches (millimeters) (Continued)

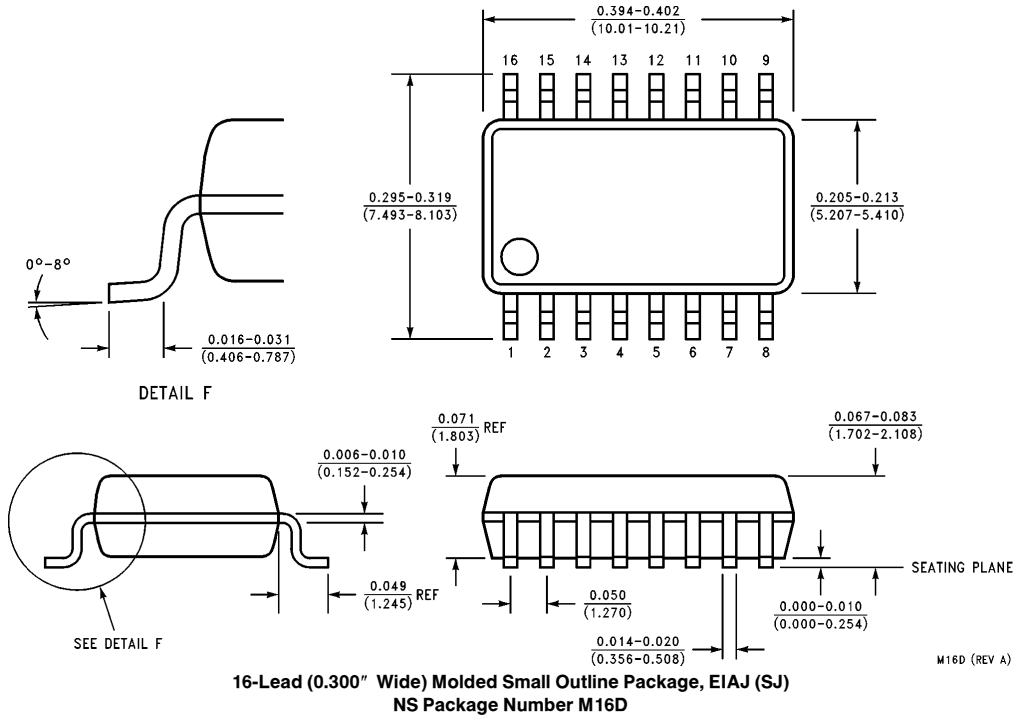

**LIFE SUPPORT POLICY**

NATIONAL'S PRODUCTS ARE NOT AUTHORIZED FOR USE AS CRITICAL COMPONENTS IN LIFE SUPPORT DEVICES OR SYSTEMS WITHOUT THE EXPRESS WRITTEN APPROVAL OF THE PRESIDENT OF NATIONAL SEMICONDUCTOR CORPORATION. As used herein:

1. Life support devices or systems are devices or systems which, (a) are intended for surgical implant into the body, or (b) support or sustain life, and whose failure to perform, when properly used in accordance with instructions for use provided in the labeling, can be reasonably expected to result in a significant injury to the user.
2. A critical component is any component of a life support device or system whose failure to perform can be reasonably expected to cause the failure of the life support device or system, or to affect its safety or effectiveness.



**National Semiconductor Corporation**  
2900 Semiconductor Drive  
P.O. Box 58090  
Santa Clara, CA 95052-8090  
Tel: 1(800) 272-9959  
TWX: (910) 339-9240

**National Semiconductor GmbH**  
Livny-Gargan-Str. 10  
D-82256 Fürstenfeldbruck  
Germany  
Tel: (81-41) 35-0  
Telex: 527849  
Fax: (81-41) 35-1

**National Semiconductor Japan Ltd.**  
Sumitomo Chemical  
Engineering Center  
Bldg. 7F  
1-7-1, Nakase, Mihama-Ku  
Chiba-City,  
Chiba Prefecture 261  
Tel: (043) 299-2300  
Fax: (043) 299-2500

**National Semiconductor Hong Kong Ltd.**  
13th Floor, Straight Block,  
Ocean Centre, 5 Canton Rd.  
Tsimshatsui, Kowloon  
Hong Kong  
Tel: (852) 2737-1600  
Fax: (852) 2736-9960

**National Semicondutores Do Brazil Ltda.**  
Rue Deputado Lacorda Franco  
120-3A  
Sao Paulo-SP  
Brazil 05418-000  
Tel: (55-11) 212-5066  
Telex: 391-1131931 NSBR BR  
Fax: (55-11) 212-1181

**National Semiconductor (Australia) Pty. Ltd.**  
Building 16  
Business Park Drive  
Monash Business Park  
Nottingham, Melbourne  
Victoria 3168 Australia  
Tel: (3) 558-9999  
Fax: (3) 558-9998

National does not assume any responsibility for use of any circuitry described, no circuit patent licenses are implied and National reserves the right at any time without notice to change said circuitry and specifications.

This datasheet has been downloaded from:

[www.DatasheetCatalog.com](http://www.DatasheetCatalog.com)

Datasheets for electronic components.

# National Semiconductor was acquired by Texas Instruments.

[http://www.ti.com/corp/docs/investor\\_relations/pr\\_09\\_23\\_2011\\_national\\_semiconductor.html](http://www.ti.com/corp/docs/investor_relations/pr_09_23_2011_national_semiconductor.html)

This file is the datasheet for the following electronic components:

74F169PC - <http://www.ti.com/product/74f169pc?HQS=TI-null-null-dscatalog-df-pf-null-ww>

74F169SJ - <http://www.ti.com/product/74f169sj?HQS=TI-null-null-dscatalog-df-pf-null-ww>

74F169SC - <http://www.ti.com/product/74f169sc?HQS=TI-null-null-dscatalog-df-pf-null-ww>



LittleDiode supplies new, hard to find or obsolete electronic components and semiconductors all over the world.

With over two million different components listed you are sure to find the part you need.

Feel free to visit us today at our online store:

[LittleDiode.com](http://LittleDiode.com)

Looking forward to providing you with the best possible service.