

## 54F/74F164A Serial-In, Parallel-Out Shift Register

### General Description

The 'F164A is a high-speed 8-bit serial-in/parallel-out shift register. Serial data is entered through a 2-input AND gate synchronous with the LOW-to-HIGH transition of the clock. The device features an asynchronous Master Reset which clears the register, setting all outputs LOW independent of the clock. The 'F164A is a faster version of the 'F164.

### Features

- Typical shift frequency of 90 MHz
- Asynchronous Master Reset
- Gated serial data input
- Fully synchronous data transfers
- Guaranteed 4000V min ESD protection
- 'F164A is a faster version of the 'F164

Commercial	Military	Package Number	Package Description
74F164APC		N14A	14-Lead (0.300" Wide) Molded Dual-In-Line
	54F164ADM (Note 2)	J14A	14-Lead Ceramic Dual-In-Line
74F164ASC (Note 1)		M14A	14-Lead (0.150" Wide) Molded Small Outline, JEDEC
74F164ASJ (Note 1)		M14D	14-Lead (0.300" Wide) Molded Small Outline, EIAJ
	74F164AFM (Note 2)	W14B	14-Lead Cerpack
	74F164ALM (Note 2)	E20A	20-Lead Ceramic Leadless Chip Carrier, Type C

**Note 1:** Devices also available in 13" reel. Use suffix = SCX and SJX.

**Note 2:** Military grade device with environmental and burn-in processing. Use suffix = DMOB, FMOB and LMOB.

### Logic Symbols

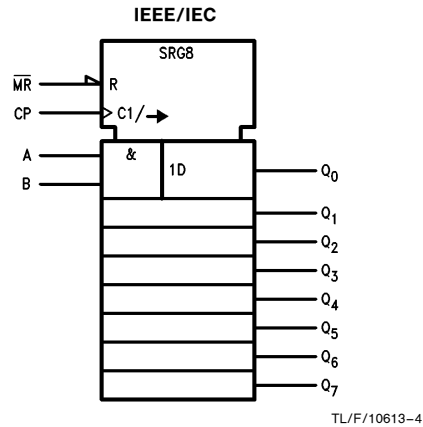
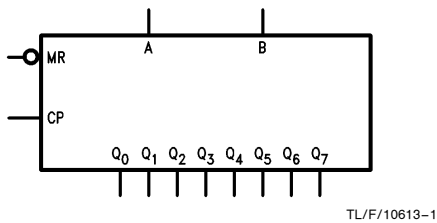

TRI-STATE® is a registered trademark of National Semiconductor Corporation.

## Connection Diagrams

Pin Assignment for  
DIP, SOIC and Flatpak

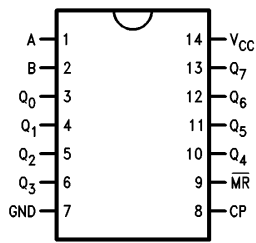

TL/F/10613-2

Pin Assignment  
for LCC

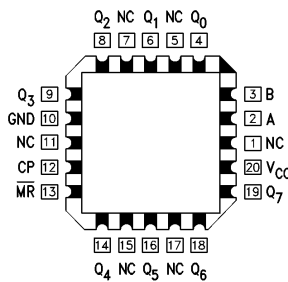

TL/F/10613-3

## Unit Loading/Fan Out

Pin Names	Description	54F/74F	
		U.L. HIGH/LOW	Input $I_{IH}/I_{IL}$ Output $I_{OH}/I_{OL}$
A, B	Data Inputs	1.0/1.0	20 $\mu A$ / -0.6 mA
CP	Clock Pulse Input (Active Rising Edge)	1.0/1.0	20 $\mu A$ / -0.6 mA
$\overline{MR}$	Master Reset Input (Active LOW)	1.0/1.0	20 $\mu A$ / -0.6 mA
$Q_0$ - $Q_7$	Outputs	50/33.3	-1 mA/20 mA

## Functional Description

The 'F164A is an edge-triggered 8-bit shift register with serial data entry and an output from each of the eight stages. Data is entered serially through one of two inputs (A or B); either of these inputs can be used as an active HIGH Enable for data entry through the other input. An unused input must be tied HIGH.

Each LOW-to-HIGH transition on the Clock (CP) input shifts data one place to the right and enters into  $Q_0$  the logical AND of the two data inputs ( $A \cdot B$ ) that existed before the rising clock edge. A LOW level on the Master Reset ( $\overline{MR}$ ) input overrides all other inputs and clears the register asynchronously, forcing all Q outputs LOW.

Mode Select Table

Operating Mode	Inputs			Outputs	
	$\overline{MR}$	A	B	$Q_0$	$Q_1$ - $Q_7$
Reset (Clear)	L	X	X	L	L-L
Shift	H	l	l	L	$Q_0$ - $Q_6$
	H	l	h	L	$Q_0$ - $Q_6$
	H	h	l	L	$Q_0$ - $Q_6$
	H	h	h	H	$Q_0$ - $Q_6$

H(h) = HIGH Voltage Levels

L(l) = LOW Voltage Levels

X = Immaterial

$q_n$  = Lower case letters indicate the state of the referenced input or output one setup time prior to the LOW-to-HIGH clock transition.

## Logic Diagram

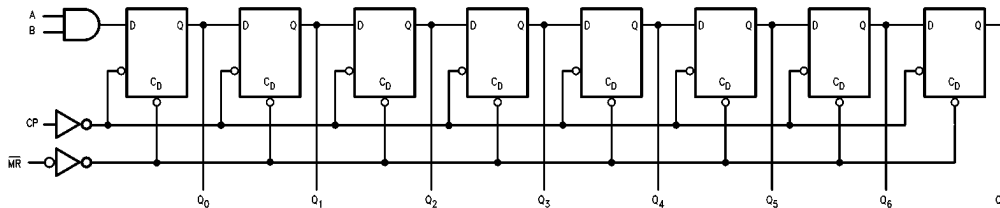

TL/F/10613-5

Please note that this diagram is provided only for the understanding of logic operations and should not be used to estimate propagation delays.

## Absolute Maximum Ratings (Note 1)

If Military/Aerospace specified devices are required, please contact the National Semiconductor Sales Office/Distributors for availability and specifications.

Storage Temperature	-65°C to +150°C
Ambient Temperature under Bias	-55°C to +125°C
Junction Temperature under Bias	-55°C to +175°C
Plastic	-55°C to +150°C
V <sub>CC</sub> Pin Potential to Ground Pin	-0.5V to +7.0V
Input Voltage (Note 2)	-0.5V to +7.0V
Input Current (Note 2)	-30 mA to +5.0 mA
Voltage Applied to Output in HIGH State (with V <sub>CC</sub> = 0V)	
Standard Output	-0.5V to V <sub>CC</sub>
TRI-STATE® Output	-0.5V to +5.5V
Current Applied to Output in LOW State (Max)	twice the rated I <sub>OL</sub> (mA)
ESD Last Passing Voltage (Min)	4000V

**Note 1:** Absolute maximum ratings are values beyond which the device may be damaged or have its useful life impaired. Functional operation under these conditions is not implied.

**Note 2:** Either voltage limit or current limit is sufficient to protect inputs.

## Recommended Operating Conditions

Free Air Ambient Temperature	
Military	-55°C to +125°C
Commercial	0°C to +70°C
Supply Voltage	
Military	+4.5V to +5.5V
Commercial	+4.5V to +5.5V

## DC Electrical Characteristics

Symbol	Parameter	54F/74F			Units	V <sub>CC</sub>	Conditions
		Min	Typ	Max			
V <sub>IH</sub>	Input HIGH Voltage	2.0			V		Recognized as a HIGH Signal
V <sub>IL</sub>	Input LOW Voltage			0.8	V		Recognized as a LOW Signal
V <sub>CD</sub>	Input Clamp Diode Voltage			-1.2	V	Min	I <sub>IN</sub> = -18 mA
V <sub>OH</sub>	Output HIGH Voltage	54F 10% V <sub>CC</sub>	2.5		V	Min	I <sub>OH</sub> = -1 mA I <sub>OH</sub> = -1 mA I <sub>OH</sub> = -1 mA
		74F 10% V <sub>CC</sub>	2.5				
		74F 5% V <sub>CC</sub>	2.7				
V <sub>OL</sub>	Output LOW Voltage	54F 10% V <sub>CC</sub>		0.5	V	Min	I <sub>OL</sub> = 20 mA I <sub>OL</sub> = 20 mA
		74F 10% V <sub>CC</sub>		0.5			
I <sub>IH</sub>	Input HIGH Current	54F		20.0	μA	Max	V <sub>IN</sub> = 2.7V
		74F		5.0			
I <sub>BVI</sub>	Input HIGH Current Breakdown Test	54F		100	μA	Max	V <sub>IN</sub> = 7.0V
		74F		7.0			
I <sub>CEX</sub>	Output HIGH Leakage Current	54F		250	μA	Max	V <sub>OUT</sub> = V <sub>CC</sub>
		74F		50			
V <sub>ID</sub>	Input Leakage Test	74F	4.75		V	0.0	I <sub>ID</sub> = 1.9 μA All other pins grounded
I <sub>OD</sub>	Output Leakage Circuit Current	74F		3.75	μA	0.0	V <sub>IOD</sub> = 150 mV All other pins grounded
I <sub>IL</sub>	Input LOW Current			-0.6	mA	Max	V <sub>IN</sub> = 0.5V
I <sub>OS</sub>	Output Short-Circuit Current			-60	mA	Max	V <sub>OUT</sub> = 0V
I <sub>CC</sub>	Power Supply Current		35	55	mA	Max	CP = HIGH MR = GND, A, B = GND

## AC Electrical Characteristics

Symbol	Parameter	74F			54F		74F		Units
		$T_A = +25^\circ\text{C}$ $V_{CC} = +5.0\text{V}$ $C_L = 50\text{ pF}$			$T_A, V_{CC} = \text{Mil}$ $C_L = 50\text{ pF}$		$T_A, V_{CC} = \text{Com}$ $C_L = 50\text{ pF}$		
		Min	Typ	Max	Min	Max	Min	Max	
$f_{\text{max}}$	Maximum Clock Frequency	80	120		60		80		MHz
$t_{\text{PLH}}$	Propagation Delay	3.0	4.8	7.5	2.5	9.0	3.0	7.5	ns
$t_{\text{PHL}}$	CP to $Q_n$	3.5	5.0	8.0	3.0	8.5	3.5	8.0	
$t_{\text{PHL}}$	Propagation Delay $\overline{\text{MR}}$ to $Q_n$	5.0	7.0	10.0	4.0	12.5	5.0	10.5	ns

## AC Operating Requirements

Symbol	Parameter	74F		54F		74F		Units
		$T_A = +25^\circ\text{C}$ $V_{CC} = +5.0\text{V}$		$T_A, V_{CC} = \text{Mil}$		$T_A, V_{CC} = \text{Com}$		
		Min	Max	Min	Max	Min	Max	
$t_s(\text{H})$	Setup Time, HIGH or LOW	4.5		5.5		4.5		ns
$t_s(\text{L})$	A or B to CP	4.0		4.0		4.0		
$t_h(\text{H})$	Hold Time, HIGH or LOW	1.0		1.0		1.0		ns
$t_h(\text{L})$	A or B to CP	1.0		1.0		1.0		
$t_w(\text{H})$	CP Pulse Width	4.0		4.0		4.0		ns
$t_w(\text{L})$	HIGH or LOW	7.0		7.0		7.0		
$t_w(\text{L})$	$\overline{\text{MR}}$ Pulse Width, LOW	4.0		5.0		4.0		ns
$t_{\text{rec}}$	Recovery Time $\overline{\text{MR}}$ to CP	5.0		6.5		5.0		ns

## Ordering Information

The device number is used to form part of a simplified purchasing code where the package type and temperature range are defined as follows:

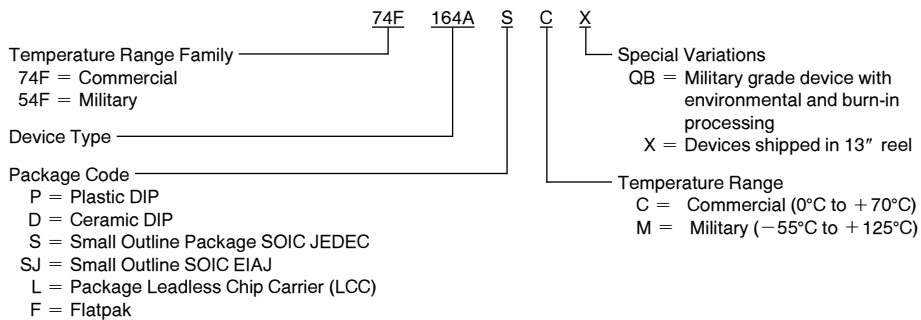

**Physical Dimensions** inches (millimeters)

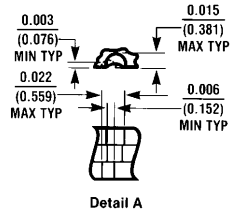
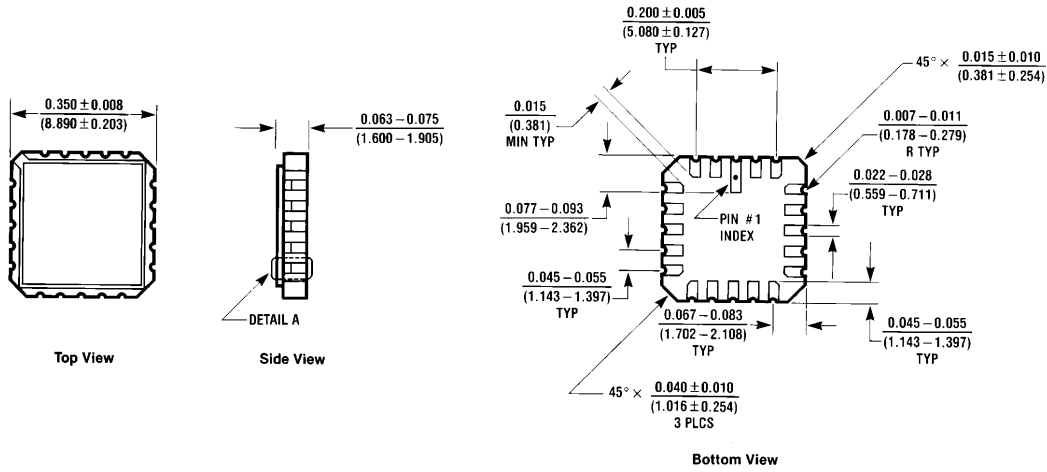

**20-Lead Ceramic Leadless Chip Carrier, Type C (L)**  
 NS Package Number E20A

E20A (REV D)

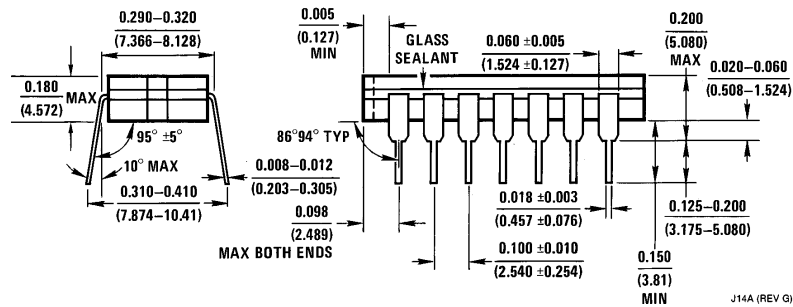
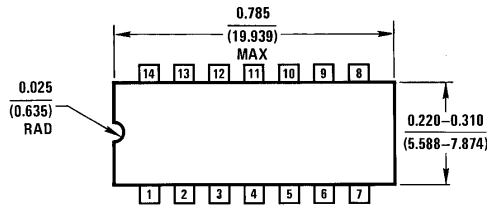

**14-Lead Ceramic Dual-In-Line Package (D)**  
 NS Package Number J14A

J14A (REV G)

**Physical Dimensions** inches (millimeters) (Continued)

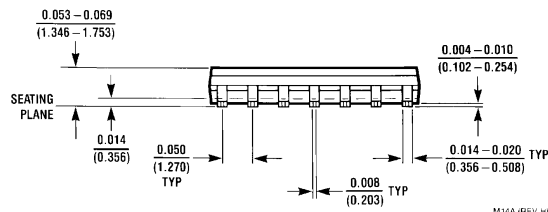
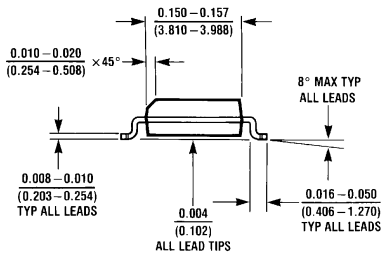
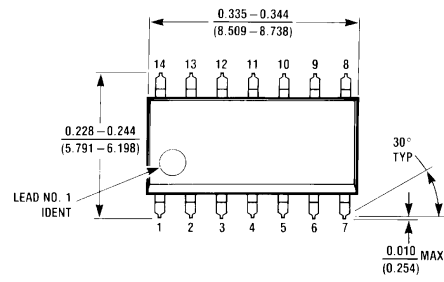

**14-Lead (0.150" Wide) Molded Small Outline Package, JEDEC (S)  
NS Package Number M14A**

M14A (REV. H)



**Physical Dimensions** inches (millimeters) (Continued)

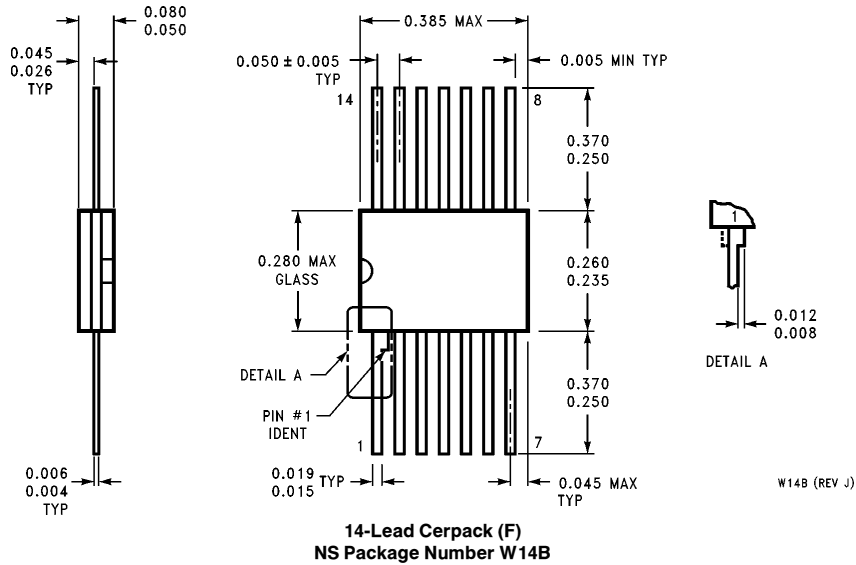

**LIFE SUPPORT POLICY**

NATIONAL'S PRODUCTS ARE NOT AUTHORIZED FOR USE AS CRITICAL COMPONENTS IN LIFE SUPPORT DEVICES OR SYSTEMS WITHOUT THE EXPRESS WRITTEN APPROVAL OF THE PRESIDENT OF NATIONAL SEMICONDUCTOR CORPORATION. As used herein:

1. Life support devices or systems are devices or systems which, (a) are intended for surgical implant into the body, or (b) support or sustain life, and whose failure to perform, when properly used in accordance with instructions for use provided in the labeling, can be reasonably expected to result in a significant injury to the user.
2. A critical component is any component of a life support device or system whose failure to perform can be reasonably expected to cause the failure of the life support device or system, or to affect its safety or effectiveness.



**National Semiconductor Corporation**  
2900 Semiconductor Drive  
P.O. Box 58090  
Santa Clara, CA 95052-8090  
Tel: (800) 272-9959  
TWX: (910) 339-9240

**National Semiconductor GmbH**  
Livny-Gargan-Str. 10  
D-82256 Fürstenfeldbruck  
Germany  
Tel: (81-41) 35-0  
Telex: 527849  
Fax: (81-41) 35-1

**National Semiconductor Japan Ltd.**  
Sumitomo Chemical  
Engineering Center  
Bldg. 7F  
1-7-1, Nakase, Mihama-Ku  
Chiba-City,  
Ciba Prefecture 261  
Tel: (043) 299-2300  
Fax: (043) 299-2500

**National Semiconductor Hong Kong Ltd.**  
13th Floor, Straight Block,  
Ocean Centre, 5 Canton Rd.  
Tsimshatsui, Kowloon  
Hong Kong  
Tel: (852) 2737-1600  
Fax: (852) 2736-9960

**National Semicondutores Do Brazil Ltda.**  
Rue Deputado Lacorda Franco  
120-3A  
Sao Paulo-SP  
Brazil 05418-000  
Tel: (55-11) 212-5066  
Telex: 391-1131931 NSBR BR  
Fax: (55-11) 212-1181

**National Semiconductor (Australia) Pty. Ltd.**  
Building 16  
Business Park Drive  
Monash Business Park  
Nottingham, Melbourne  
Victoria 3168 Australia  
Tel: (3) 558-9999  
Fax: (3) 558-9998

National does not assume any responsibility for use of any circuitry described, no circuit patent licenses are implied and National reserves the right at any time without notice to change said circuitry and specifications.

This datasheet has been downloaded from:

[www.DatasheetCatalog.com](http://www.DatasheetCatalog.com)

Datasheets for electronic components.

# National Semiconductor was acquired by Texas Instruments.

[http://www.ti.com/corp/docs/investor\\_relations/pr\\_09\\_23\\_2011\\_national\\_semiconductor.html](http://www.ti.com/corp/docs/investor_relations/pr_09_23_2011_national_semiconductor.html)

This file is the datasheet for the following electronic components:

74F164ASC - <http://www.ti.com/product/74f164asc?HQS=TI-null-null-dscatalog-df-pf-null-wwe>

74F164APC - <http://www.ti.com/product/74f164apc?HQS=TI-null-null-dscatalog-df-pf-null-wwe>

74F164ASJ - <http://www.ti.com/product/74f164asj?HQS=TI-null-null-dscatalog-df-pf-null-wwe>

74F164ALM - <http://www.ti.com/product/74f164alm?HQS=TI-null-null-dscatalog-df-pf-null-wwe>

74F164AFM - <http://www.ti.com/product/74f164afm?HQS=TI-null-null-dscatalog-df-pf-null-wwe>



LittleDiode supplies new, hard to find or obsolete electronic components and semiconductors all over the world.

With over two million different components listed you are sure to find the part you need.

Feel free to visit us today at our online store:

[LittleDiode.com](http://LittleDiode.com)

Looking forward to providing you with the best possible service.