

# DATA SHEET

For a complete data sheet, please also download:

- The IC06 74HC/HCT/HCU/HCMOS Logic Family Specifications
- The IC06 74HC/HCT/HCU/HCMOS Logic Package Information
- The IC06 74HC/HCT/HCU/HCMOS Logic Package Outlines

## **74HC/HCT195** 4-bit parallel access shift register

Product specification  
File under Integrated Circuits, IC06

December 1990

## 4-bit parallel access shift register

## 74HC/HCT195

## FEATURES

- Asynchronous master reset
- J,  $\bar{K}$ , (D) inputs to the first stage
- Fully synchronous serial or parallel data transfer
- Shift right and parallel load capability
- Complement output from the last stage
- Output capability: standard
- I<sub>CC</sub> category: MSI

## GENERAL DESCRIPTION

The 74HC/HCT195 are high-speed Si-gate CMOS devices and are pin compatible with low power Schottky TTL (LSTTL). They are specified in compliance with JEDEC standard no. 7A.

The 74HC/HCT195 performs serial, parallel, serial-to-parallel or parallel-to-serial data transfer at very high speeds. The "195" operates on two primary modes: shift right ( $Q_0 \rightarrow Q_1$ ) and parallel load, which are controlled

by the state of the parallel load enable ( $\overline{PE}$ ) input. Serial data enters the first flip-flop ( $Q_0$ ) via the J and  $\bar{K}$  inputs when the  $\overline{PE}$  input is HIGH and shifted one bit in the direction  $Q_0 \rightarrow Q_1 \rightarrow Q_2 \rightarrow Q_3$  following each LOW-to-HIGH clock transition. The J and  $\bar{K}$  inputs provide the flexibility of the JK type input for special applications and by tying the pins together, the simple D-type input for general applications. The "195" appears as four common clocked D flip-flops when the  $\overline{PE}$  input is LOW.

After the LOW-to-HIGH clock transition, data on the parallel inputs ( $D_0$  to  $D_3$ ) is transferred to the respective  $Q_0$  to  $Q_3$  outputs. Shift left operation ( $Q_3 \rightarrow Q_2$ ) can be achieved by tying the  $Q_n$  outputs to the  $D_{n-1}$  inputs and holding the  $\overline{PE}$  input LOW.

All parallel and serial data transfers are synchronous, occurring after each LOW-to-HIGH clock transition. There is no restriction on the activity of the J,  $\bar{K}$ ,  $D_n$  and  $\overline{PE}$  inputs for logic operation other than the set-up and hold time requirements. A LOW on the asynchronous master reset ( $\overline{MR}$ ) input sets all Q outputs LOW, independent of any other input condition.

## QUICK REFERENCE DATA

GND = 0 V; T<sub>amb</sub> = 25 °C; t<sub>r</sub> = t<sub>f</sub> = 6 ns

SYMBOL	PARAMETER	CONDITIONS	TYPICAL		UNIT
			HC	HCT	
t <sub>PHL</sub> / t <sub>PLH</sub>	propagation delay CP to Q <sub>n</sub>	C <sub>L</sub> = 15 pF; V <sub>CC</sub> = 5 V	15	15	ns
f <sub>max</sub>	maximum clock frequency		57	57	MHz
C <sub>I</sub>	input capacitance		3.5	3.5	pF
C <sub>PD</sub>	power dissipation capacitance per package	notes 1 and 2	105	105	pF

## Notes

1. C<sub>PD</sub> is used to determine the dynamic power dissipation (P<sub>D</sub> in μW):

$$P_D = C_{PD} \times V_{CC}^2 \times f_i + \sum (C_L \times V_{CC}^2 \times f_o) \quad \text{where:}$$

f<sub>i</sub> = input frequency in MHz

f<sub>o</sub> = output frequency in MHz

$\sum (C_L \times V_{CC}^2 \times f_o)$  = sum of outputs

C<sub>L</sub> = output load capacitance in pF

V<sub>CC</sub> = supply voltage in V

2. For HC the condition is V<sub>I</sub> = GND to V<sub>CC</sub>  
For HCT the condition is V<sub>I</sub> = GND to V<sub>CC</sub> - 1,5 V

## ORDERING INFORMATION

See "74HC/HCT/HCU/HCMOS Logic Package Information".

# 4-bit parallel access shift register

# 74HC/HCT195

## PIN DESCRIPTION

PIN NO.	SYMBOL	NAME AND FUNCTION
1	$\overline{MR}$	master reset input (active LOW)
2	J	first stage J-input (active HIGH)
3	$\overline{K}$	first stage $\overline{K}$ -input (active LOW)
4, 5, 6, 7	D <sub>0</sub> to D <sub>3</sub>	parallel data inputs
8	GND	ground (0 V)
9	$\overline{PE}$	parallel enable input (active LOW)
10	CP	clock input (LOW-to-HIGH edge-triggered)
11	$\overline{Q}_3$	inverted output from the last stage
15, 14, 13, 12	Q <sub>0</sub> to Q <sub>3</sub>	parallel outputs
16	V <sub>CC</sub>	positive supply voltage

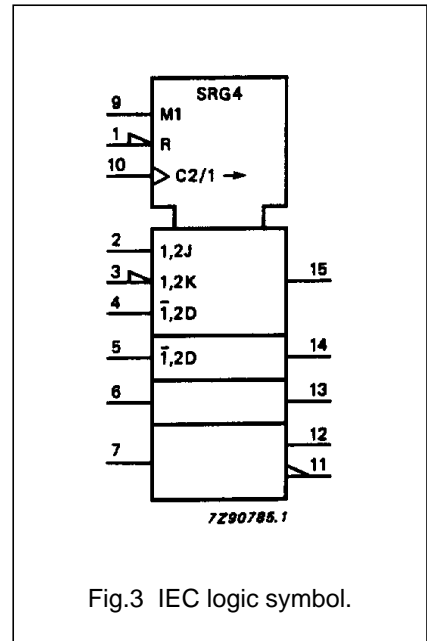
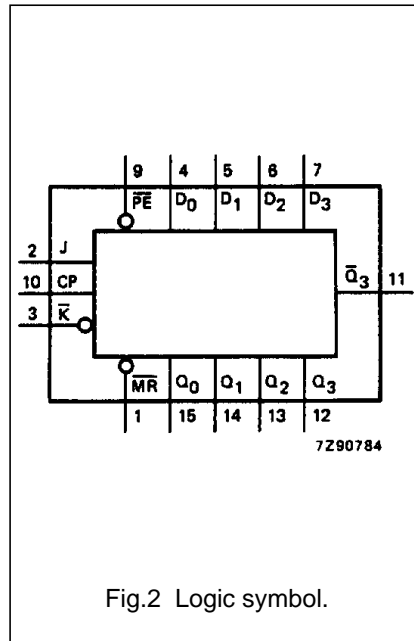
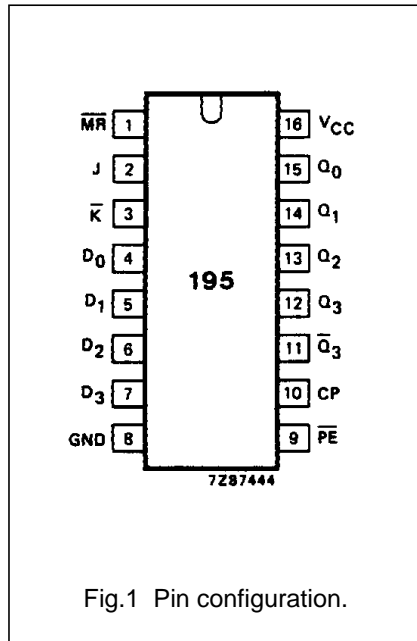

4-bit parallel access shift register

74HC/HCT195

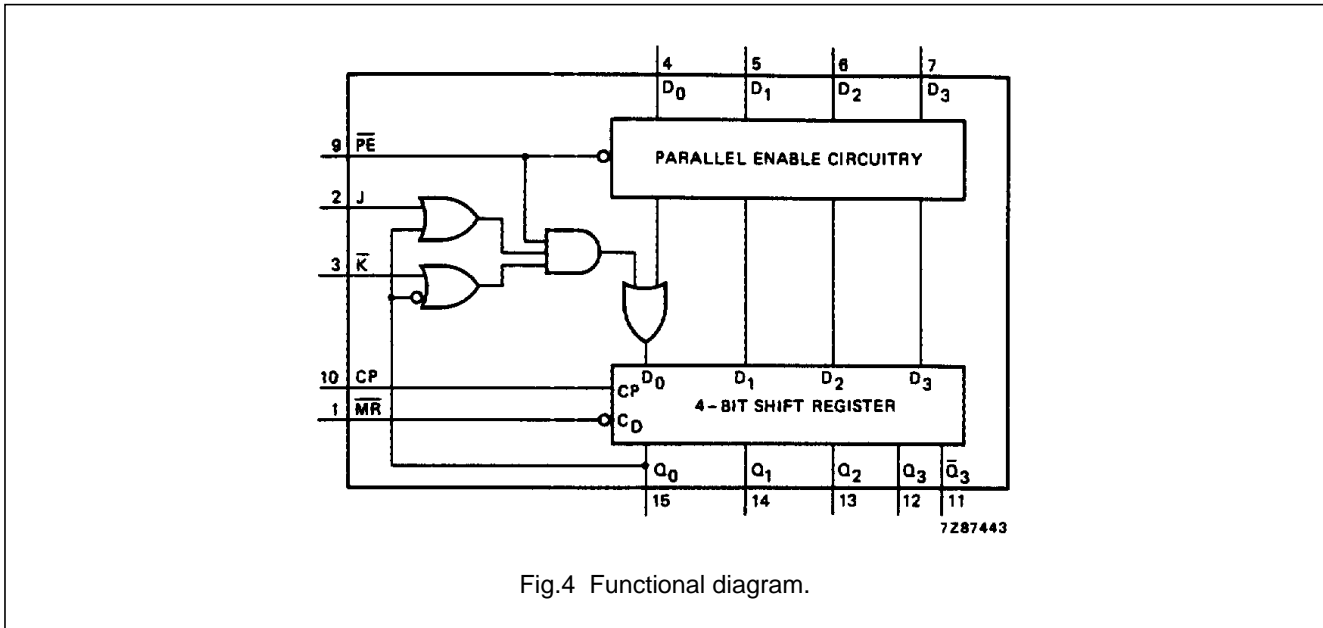

Fig.4 Functional diagram.

APPLICATIONS

- Serial data transfer
- Parallel data transfer
- Serial-to-parallel data transfer
- Parallel-to-serial data transfer

FUNCTION TABLE

OPERATING MODES	INPUTS						OUTPUTS				
	$\overline{MR}$	CP	$\overline{PE}$	J	$\overline{K}$	$D_n$	$Q_0$	$Q_1$	$Q_2$	$Q_3$	$\overline{Q_3}$
asynchronous reset	L	X	X	X	X	X	L	L	L	L	H
shift, set first stage	H	↑	h	h	h	X	H	q0	q1	q2	$\overline{q_2}$
shift, reset first stage	H	↑	h	l	l	X	$\overline{L}$	q0	q1	q2	$\overline{q_2}$
shift, toggle first stage	H	↑	h	h	l	X	q0	q0	q1	q2	$\overline{q_2}$
shift, retain first stage	H	↑	h	l	h	X	q0	q0	q1	q2	$\overline{q_2}$
parallel load	H	↑	l	X	X	$d_n$	$d_0$	$d_1$	$d_2$	$d_3$	$\overline{d_3}$

Notes

- H = HIGH voltage level

h = HIGH voltage level one set-up time prior to the LOW-to-HIGH clock transition

L = LOW voltage level

l = LOW voltage level one set-up time prior to the LOW-to-HIGH clock transition

q, d = lower case letters indicate the state of the referenced input (or output) one set-up time prior to the LOW-to-HIGH clock transition

X = don't care

↑ = LOW-to-HIGH clock transition

4-bit parallel access shift register

74HC/HCT195

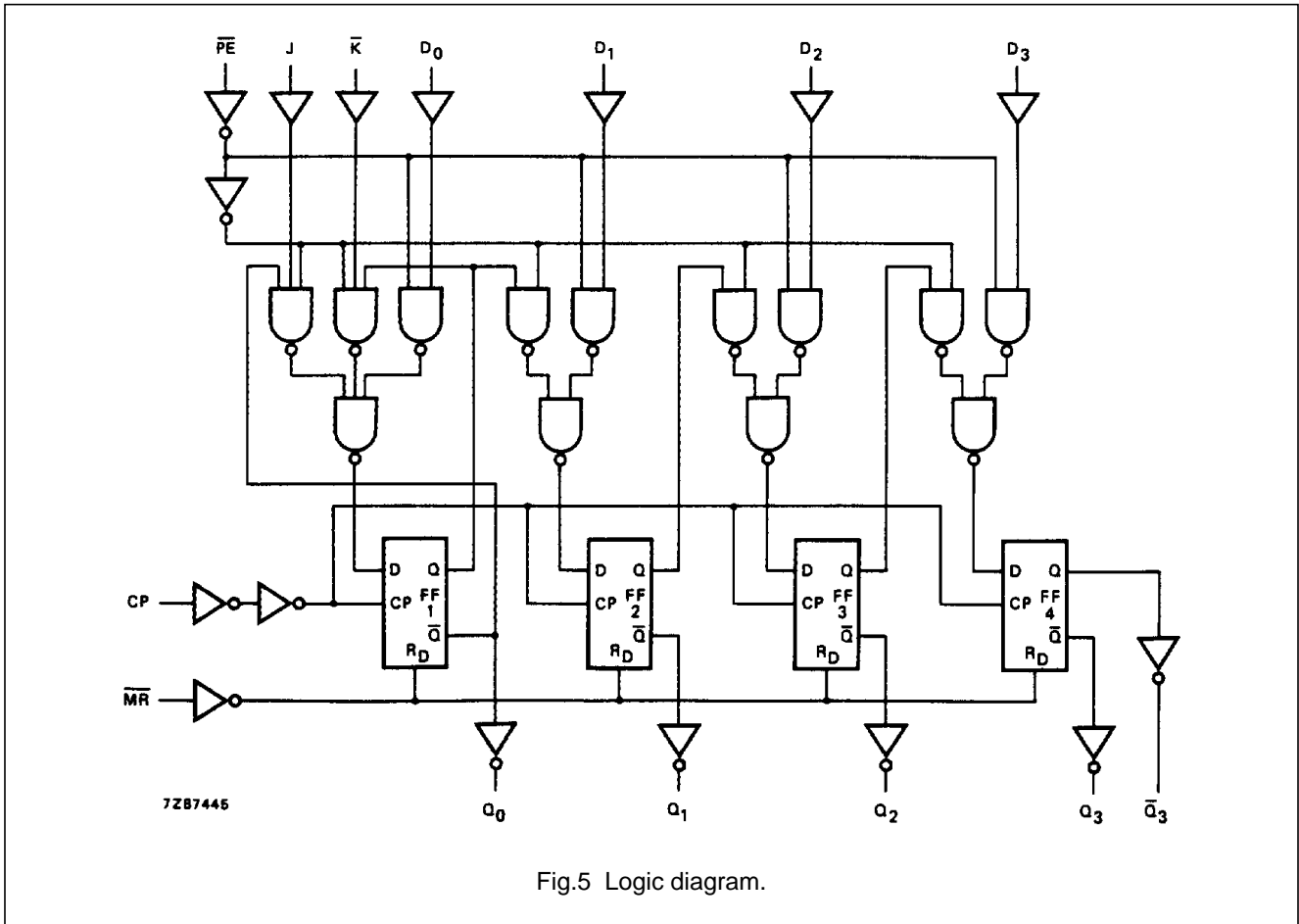

## 4-bit parallel access shift register

## 74HC/HCT195

**DC CHARACTERISTICS FOR 74HC**

For the DC characteristics see *"74HC/HCT/HCU/HCMOS Logic Family Specifications"*.

Output capability: standard

I<sub>CC</sub> category: MSI

**AC CHARACTERISTICS FOR 74HC**

GND = 0 V; t<sub>r</sub> = t<sub>f</sub> = 6 ns; C<sub>L</sub> = 50 pF

SYMBOL	PARAMETER	T <sub>amb</sub> (°C)						UNIT	TEST CONDITIONS		
		74HC							V <sub>CC</sub> (V)	WAVEFORMS	
		+25			-40 to +85		-40 to +125				
		min.	typ.	max.	min.	max.	min.				max.
t <sub>PHL</sub> / t <sub>PLH</sub>	propagation delay CP to Q <sub>n</sub>		50 18 14	150 30 26		190 38 33		225 45 38	ns	2.0 4.5 6.0	Fig.6
t <sub>PHL</sub>	propagation delay MR to Q <sub>n</sub>		41 15 12	150 30 26		190 38 33		225 45 38	ns	2.0 4.5 6.0	Fig.8
t <sub>THL</sub> / t <sub>TLH</sub>	output transition time		19 7 6	75 15 13		95 19 16		110 22 19	ns	2.0 4.5 6.0	Fig.6
t <sub>w</sub>	clock pulse width HIGH or LOW	80 16 14	17 6 5		100 20 17		120 24 20		ns	2.0 4.5 6.0	Fig.6
t <sub>w</sub>	master reset pulse width LOW	80 16 14	11 4 3		100 20 17		120 24 20		ns	2.0 4.5 6.0	Fig.8
t <sub>rem</sub>	removal time MR to CP	80 16 14	17 6 5		100 20 17		120 24 20		ns	2.0 4.5 6.0	Fig.8
t <sub>su</sub>	set-up time J to CP	100 20 17	33 12 10		125 25 21		150 30 26		ns	2.0 4.5 6.0	Figs 8 and 9
t <sub>su</sub>	set-up time K̄, PĒ, D <sub>n</sub> to CP	80 16 14	25 9 7		100 20 17		120 24 20		ns	2.0 4.5 6.0	Figs 8 and 9
t <sub>h</sub>	hold time J, K̄, PĒ, D <sub>n</sub> to CP	3 3 3	-8 -3 -2		3 3 3		3 3 3		ns	2.0 4.5 6.0	Figs 8 and 9
f <sub>max</sub>	maximum clock pulse frequency	6 30 35	17 52 62		5 24 28		4 20 24		MHz	2.0 4.5 6.0	Fig.6

## 4-bit parallel access shift register

## 74HC/HCT195

**DC CHARACTERISTICS FOR HCT**

For the DC characteristics see *"74HC/HCT/HCU/HCMOS Logic Family Specifications"*.

Output capability: standard

I<sub>CC</sub> category: MSI

**Note to HCT types**

The value of additional quiescent supply current ( $\Delta I_{CC}$ ) for a unit load of 1 is given in the family specifications. To determine  $\Delta I_{CC}$  per input, multiply this value by the unit load coefficient shown in the table below.

INPUT	UNIT LOAD COEFFICIENT
$\overline{PE}$	0.65
all others	0.35

**AC CHARACTERISTICS FOR 74HCT**

GND = 0 V;  $t_r = t_f = 6$  ns;  $C_L = 50$  pF

SYMBOL	PARAMETER	T <sub>amb</sub> (°C)						UNIT	TEST CONDITIONS		
		74HCT							V <sub>CC</sub> (V)	WAVEFORMS	
		+25			-40 to +85		-40 to +125				
		min.	typ.	max.	min.	max.	min.				max.
t <sub>PHL</sub> / t <sub>PLH</sub>	propagation delay CP to Q <sub>n</sub>		18	32		40		48	ns	4.5	Fig.6
t <sub>PHL</sub>	propagation delay MR to Q <sub>n</sub>		17	35		44		53	ns	4.5	Fig.8
t <sub>THL</sub> / t <sub>TLH</sub>	output transition time		7	15		19		22	ns	4.5	Fig.6
t <sub>W</sub>	clock pulse width HIGH or LOW	20	6		25		30		ns	4.5	Fig.6
t <sub>W</sub>	master reset pulse width LOW	16	6		20		24		ns	4.5	Fig.8
t <sub>rem</sub>	removal time $\overline{MR}$ to CP	16	6		20		24		ns	4.5	Fig.8
t <sub>su</sub>	set-up time J, $\overline{K}$ , $\overline{PE}$ to CP	20	12		25		30		ns	4.5	Figs 8 and 9
t <sub>su</sub>	set-up time D <sub>n</sub> to CP	16	6		20		24		ns	4.5	Figs 8 and 9
t <sub>h</sub>	hold time J, $\overline{K}$ , $\overline{PE}$ , D <sub>n</sub> to CP	3	-5		3		3		ns	4.5	Figs 8 and 9
f <sub>max</sub>	maximum clock pulse frequency	27	52		22		18		MHz	4.5	Fig.6

4-bit parallel access shift register

74HC/HCT195

AC WAVEFORMS

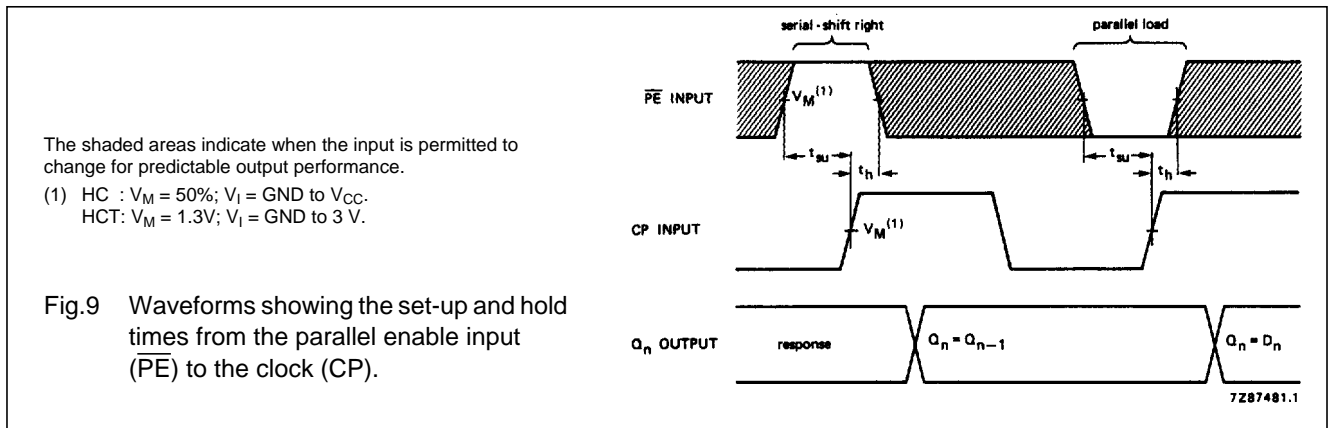
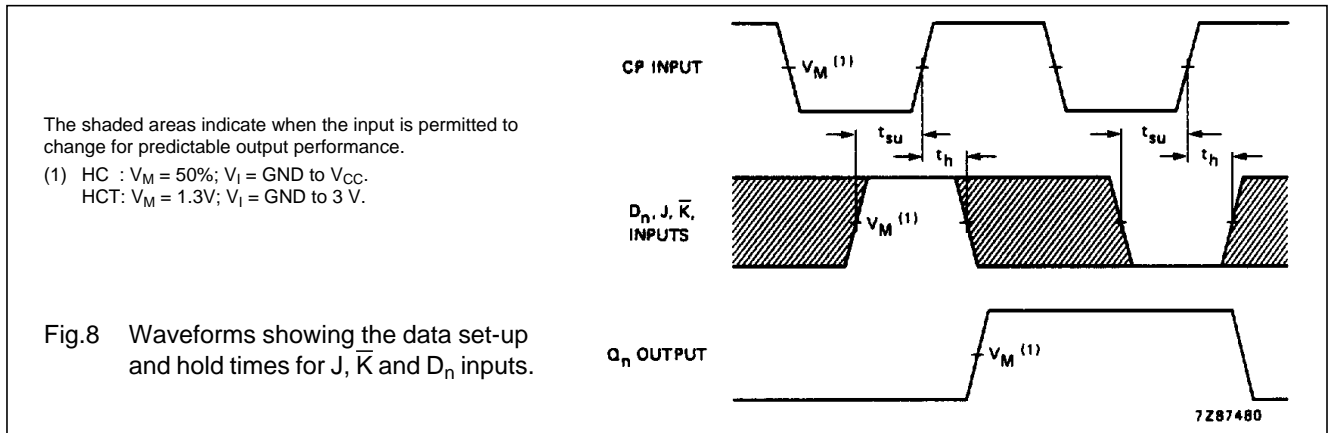
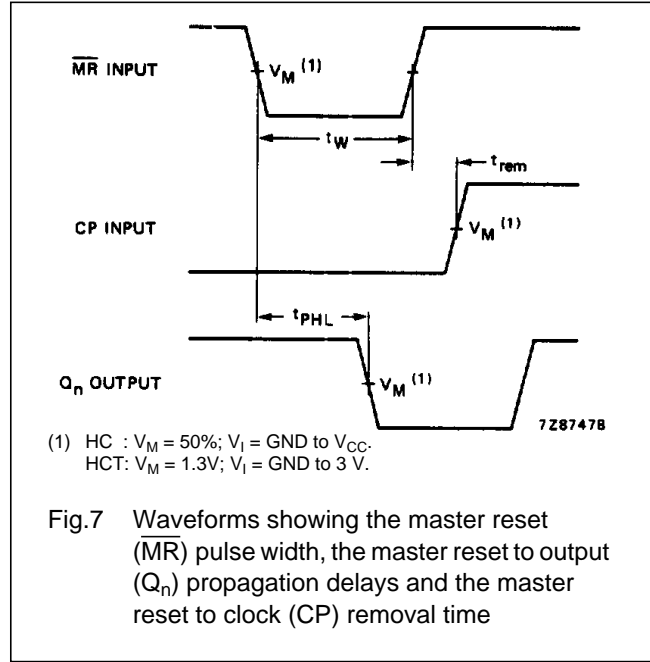
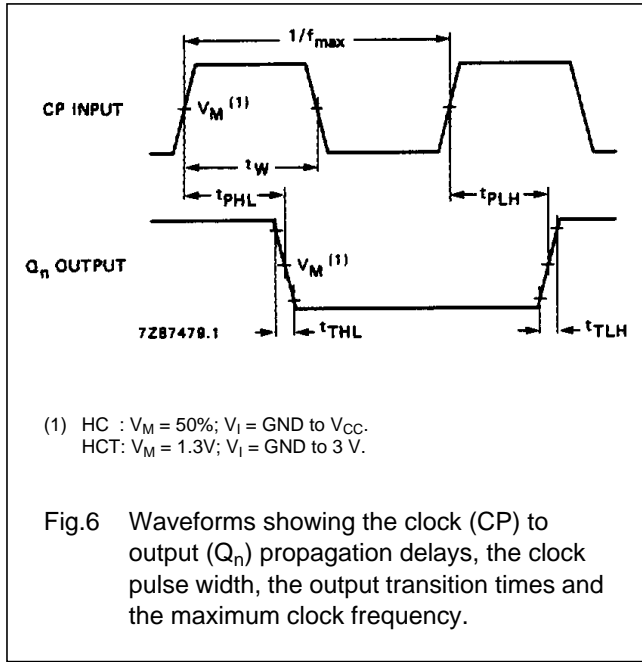

4-bit parallel access shift register

74HC/HCT195

---

**PACKAGE OUTLINES**

See *"74HC/HCT/HCU/HCMOS Logic Package Outlines"*.



LittleDiode supplies new, hard to find or obsolete electronic components and semiconductors all over the world.

With over two million different components listed you are sure to find the part you need.

Feel free to visit us today at our online store:

[LittleDiode.com](http://LittleDiode.com)

Looking forward to providing you with the best possible service.