

QUAD BUS TRANSCEIVER (3-STATE)

- HIGH SPEED
 $t_{PD} = 9 \text{ ns}$ (TYP.) AT $V_{CC} = 5 \text{ V}$
- LOW POWER DISSIPATION
 $I_{CC} = 4 \mu\text{A}$ (MAX.) AT 25°C
- OUTPUT DRIVE CAPABILITY
 15 LSTTL LOADS
- BALANCED PROPAGATION DELAYS
 $t_{PLH} = t_{PHL}$
- SYMMETRICAL OUTPUT IMPEDANCE
 $I_{OL} = |I_{OH}| = 6 \text{ mA}$ (MIN.)
- HIGH NOISE IMMUNITY
 $V_{NIH} = V_{NIL} = 28\% V_{CC}$ (MIN.)
- WIDE OPERATING VOLTAGE RANGE
 V_{CC} (OPR) = 2 V TO 6 V
- PIN AND FUNCTION COMPATIBLE
 WITH 54/74LS242/243

DESCRIPTION

The M54/74HC242/243 are high speed CMOS QUAD BUS TRANSCEIVER (3-STATE) FABRICATED IN SILICON GATE C²MOS technology. They have the same high speed performance of LSTTL combined with true CMOS low power consumption. The HC242/243 are 3 STATE bi-directional inverting and non-inverting buffers and are intended for two-way asynchronous communication between data buses. They are high drive current outputs which enable high speed operation when driving large bus capacitances. Each device has one active high enable (GBA), and one active low enable ($\overline{\text{GAB}}$). GBA enables the A outputs and $\overline{\text{GAB}}$ enables the B outputs. All inputs are equipped with protection circuits against static discharge and transient excess voltage.

INPUT AND OUTPUT EQUIVALENT CIRCUIT

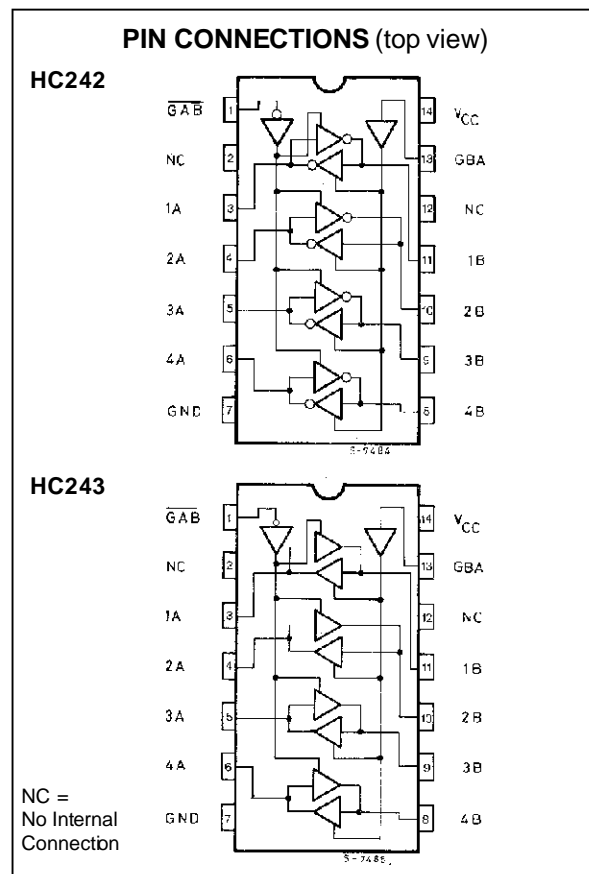
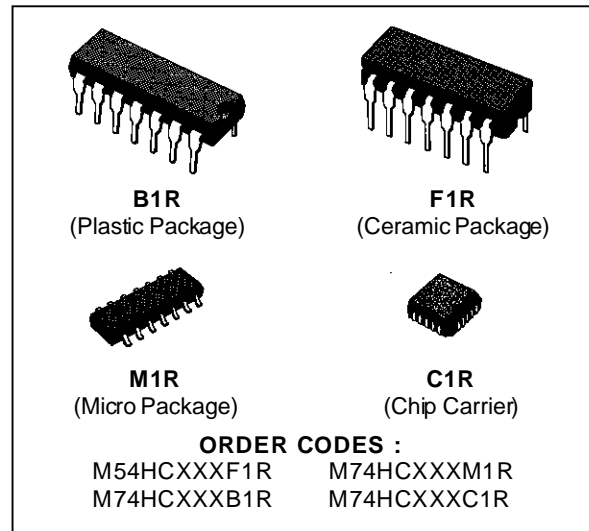
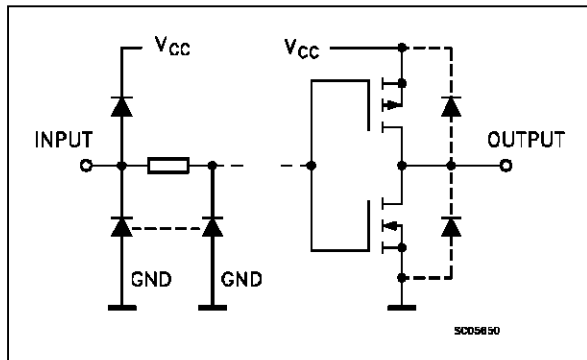

M54/M74HC242/243

CHIP CARRIER

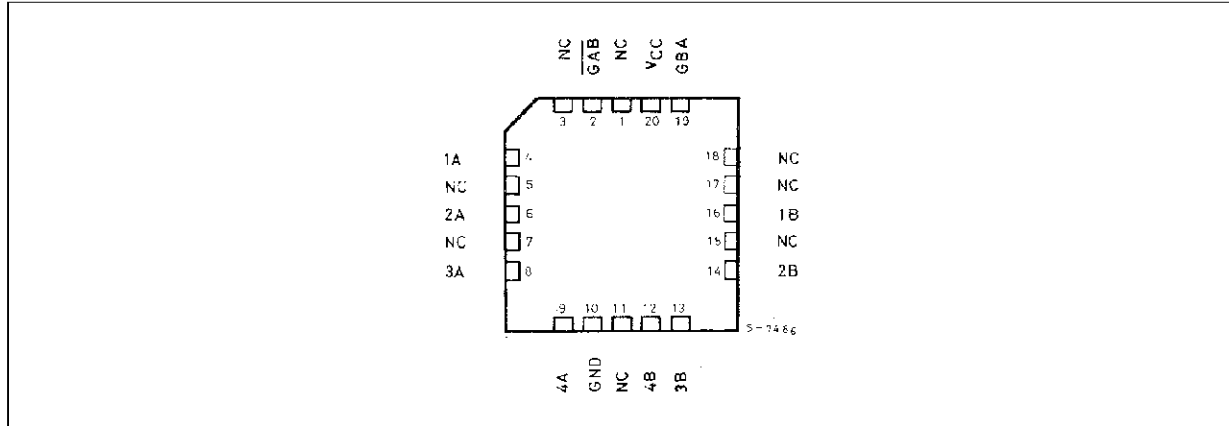

TRUTH TABLE

INPUTS		FUNCTION		OUTPUTS	
$\overline{\text{GAB}}$	GBA	A BUS	B BUS	HC242	HC243
H	H	OUTPUT	INPUT	$A = \overline{B}$	$A = B$
L	L	INPUT	OUTPUT	$B = \overline{A}$	$B = A$
H	L	HIGH IMPEDANCE		Z	Z
L	H	HIGH IMPEDANCE		Z	Z

PIN DESCRIPTION

PIN No	SYMBOL	NAME AND FUNCTION
1	$\overline{\text{GAB}}$	Output Enable Input (active LOW)
2, 12	NC	Not connected
3, 4, 5, 6	1A to 4A	Data Inputs/Outputs
11, 10, 9, 8	1B to 4B	Data Inputs/Outputs
13	GBA	Output Enable Input
7	GND	Ground (0V)
14	VCC	Positive Supply Voltage

IEC LOGIC SYMBOLS

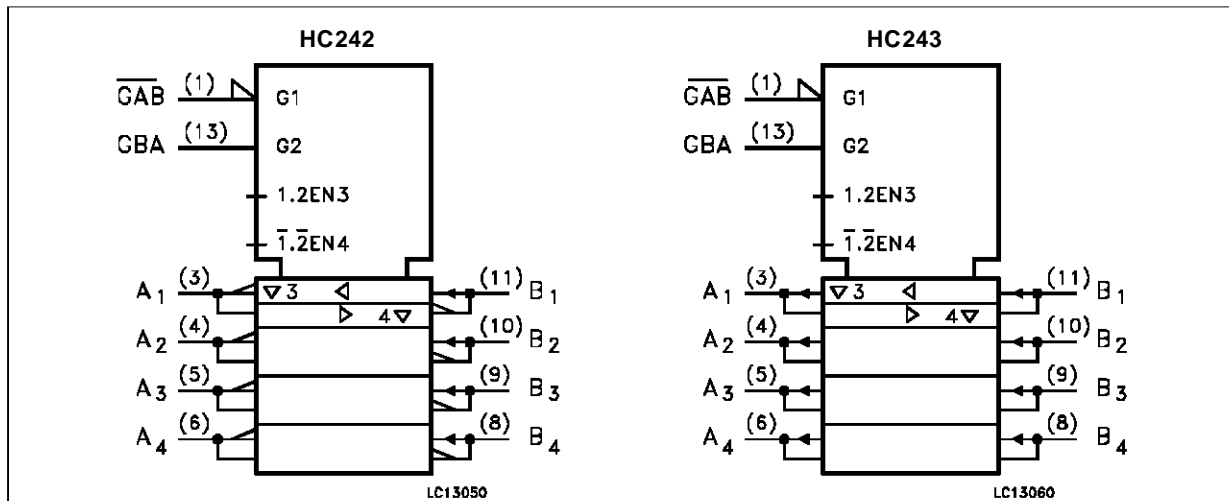

CIRCUIT DIAGRAM

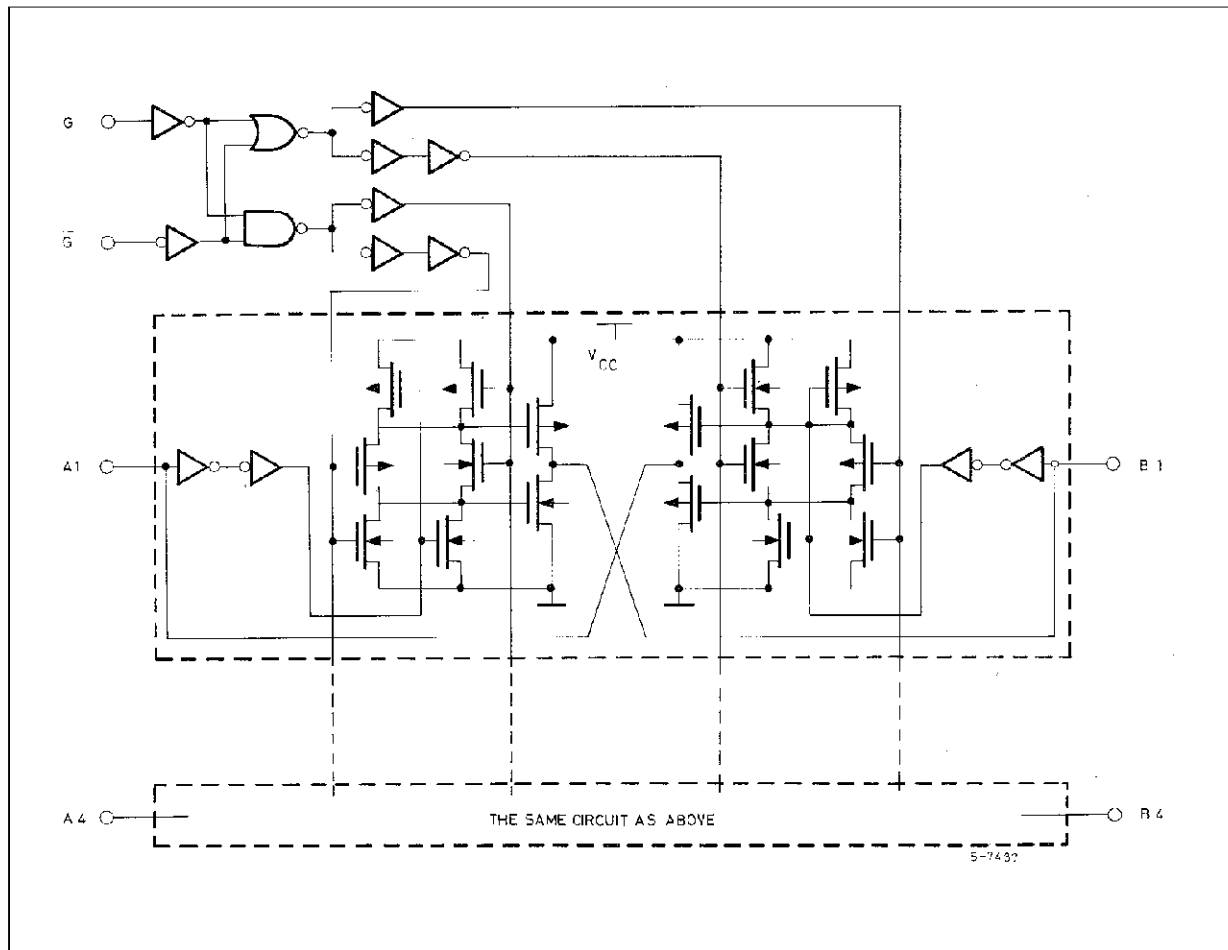

ABSOLUTE MAXIMUM RATINGS

Symbol	Parameter	Value	Unit
V_{CC}	Supply Voltage	-0.5 to +7	V
V_I	DC Input Voltage	-0.5 to $V_{CC} + 0.5$	V
V_O	DC Output Voltage	-0.5 to $V_{CC} + 0.5$	V
I_{IK}	DC Input Diode Current	± 20	mA
I_{OK}	DC Output Diode Current	± 20	mA
I_O	DC Output Source Sink Current Per Output Pin	± 35	mA
I_{CC} or I_{GND}	DC V_{CC} or Ground Current	± 70	mA
P_D	Power Dissipation	500 (*)	mW
T_{stg}	Storage Temperature	-65 to +150	$^{\circ}C$
T_L	Lead Temperature (10 sec)	300	$^{\circ}C$

Absolute Maximum Ratings are those values beyond which damage to the device may occur. Functional operation under these condition is not implied.

(*) 500 mW: $\cong 65^{\circ}C$ derate to 300 mW by 10mW/ $^{\circ}C$: $65^{\circ}C$ to $85^{\circ}C$

RECOMMENDED OPERATING CONDITIONS

Symbol	Parameter	Value	Unit	
V_{CC}	Supply Voltage	2 to 6	V	
V_I	Input Voltage	0 to V_{CC}	V	
V_O	Output Voltage	0 to V_{CC}	V	
T_{op}	Operating Temperature: M54HC Series M74HC Series	-55 to +125 -40 to +85	°C °C	
t_r, t_f	Input Rise and Fall Time	$V_{CC} = 2\text{ V}$	0 to 1000	ns
		$V_{CC} = 4.5\text{ V}$	0 to 500	
		$V_{CC} = 6\text{ V}$	0 to 400	

DC SPECIFICATIONS

Symbol	Parameter	Test Conditions		Value						Unit		
				$T_A = 25\text{ °C}$ 54HC and 74HC			$-40\text{ to }85\text{ °C}$ 74HC		$-55\text{ to }125\text{ °C}$ 54HC			
				Min.	Typ.	Max.	Min.	Max.	Min.		Max.	
V_{IH}	High Level Input Voltage	2.0 4.5 6.0		1.5			1.5		1.5		V	
				3.15			3.15		3.15			
				4.2			4.2		4.2			
V_{IL}	Low Level Input Voltage	2.0 4.5 6.0				0.5		0.5		0.5	V	
						1.35		1.35		1.35		
						1.8		1.8		1.8		
V_{OH}	High Level Output Voltage	2.0 4.5 6.0 4.5 6.0	$V_I = V_{IH}$ or V_{IL}	$I_O = -20\text{ }\mu\text{A}$	1.9	2.0		1.9		1.9		V
					4.4	4.5		4.4		4.4		
					5.9	6.0		5.9		5.9		
				4.18	4.31		4.13		4.10			
				5.68	5.8		5.63		5.60			
V_{OL}	Low Level Output Voltage	2.0 4.5 6.0 4.5 6.0	$V_I = V_{IH}$ or V_{IL}	$I_O = 20\text{ }\mu\text{A}$		0.0	0.1		0.1		0.1	V
						0.0	0.1		0.1		0.1	
						0.0	0.1		0.1		0.1	
					0.17	0.26		0.33		0.40		
					0.18	0.26		0.33		0.40		
I_I	Input Leakage Current	6.0	$V_I = V_{CC}$ or GND			± 0.1		± 1		± 1	μA	
I_{OZ}	3 State Output Off-state Current	6.0	$V_I = V_{IH}$ or V_{IL} $V_O = V_{CC}$ or GND			± 0.5		± 5		± 10	μA	
I_{CC}	Quiescent Supply Current	6.0	$V_I = V_{CC}$ or GND			4		40		80	μA	

AC ELECTRICAL CHARACTERISTICS (Input $t_r = t_f = 6$ ns)

Symbol	Parameter	Test Conditions		Value						Unit		
		V_{CC} (V)	C_L (pF)	$T_A = 25\text{ }^\circ\text{C}$ 54HC and 74HC			$-40\text{ to }85\text{ }^\circ\text{C}$ 74HC		$-55\text{ to }125\text{ }^\circ\text{C}$ 54HC			
				Min.	Typ.	Max.	Min.	Max.	Min.		Max.	
t_{TLH} t_{THL}	Output Transition Time	2.0 4.5 6.0	50		25 7 6	60 12 10		75 15 13	90 18 15	ns		
t_{PLH} t_{PHL}	Propagation Delay Time	2.0 4.5 6.0	50		39 13 11	90 18 15		115 23 20	135 27 23	ns		
		2.0 4.5 6.0	150		51 17 14	145 29 25		180 36 31	220 44 37	ns		
t_{PZL} t_{PZH}		3 State Output Enable Time	2.0 4.5 6.0	50	$R_L = 1\text{ K}\Omega$	57 18 15	145 29 25		180 36 31	220 44 37	ns	
			2.0 4.5 6.0	150	$R_L = 1\text{ K}\Omega$	70 22 19	175 35 30		220 44 37	265 53 45	ns	
t_{PLZ} t_{PHZ}			3 State Output Disable Time	2.0 4.5 6.0	50	$R_L = 1\text{ K}\Omega$	45 20 17	150 30 26		190 38 32	225 45 38	ns
C_{IN}				Input Capacitance			5	10		10	10	pF
C_{PD} (*)	Power Dissipation Capacitance					for HC242 for HC243		30 35				pF

(*) C_{PD} is defined as the value of the IC's internal equivalent capacitance which is calculated from the operating current consumption without load. (Refer to Test Circuit). Average operating current can be obtained by the following equation. $I_{CC(opr)} = C_{PD} \cdot V_{CC} \cdot f_{IN} + I_{CC}$

SWITCHING CHARACTERISTICS TEST WAVEFORM

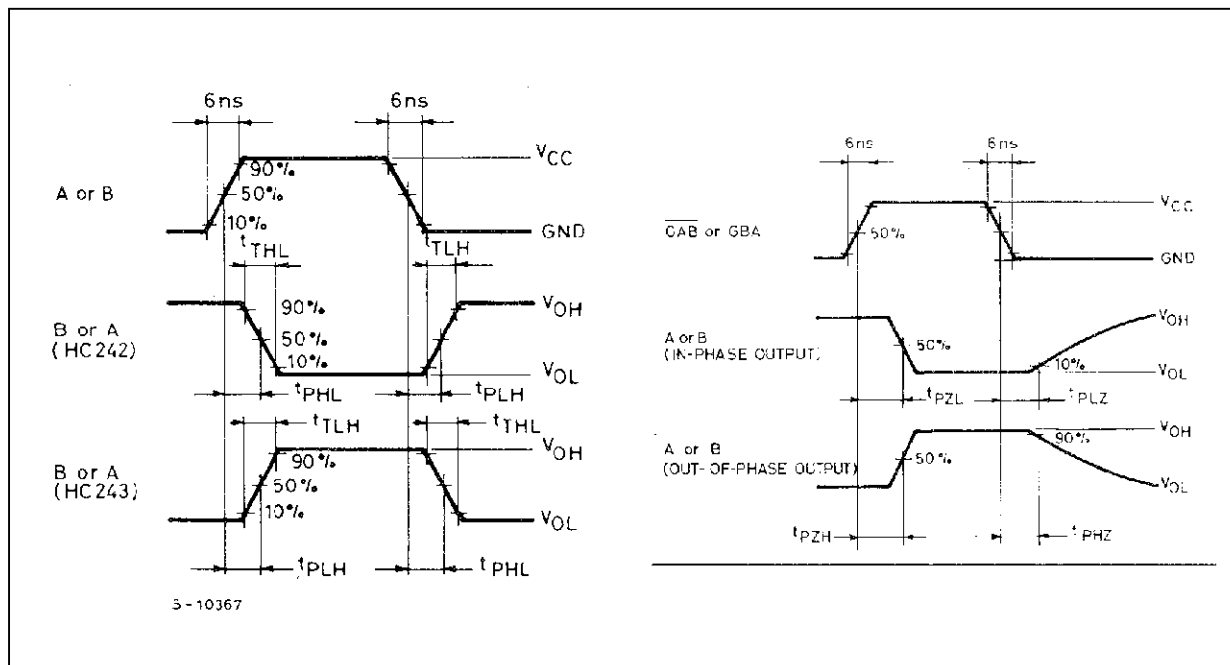

TEST CIRCUIT I_{CC} (Opr.)

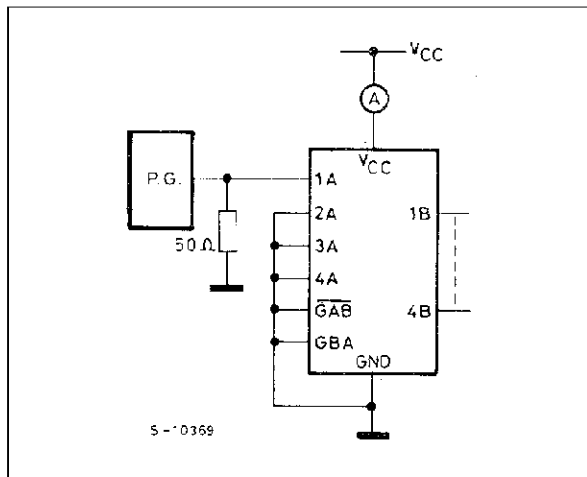

C_{PD} CALCULATION

C_{PD} is to be calculated with the following formula by using the measured value of I_{CC} (Opr.) in the test circuit opposite

$$C_{PD} = \frac{I_{CC} (Opr.)}{f_{IN} \times V_{CC}}$$

In determining the typical value of C_{PD} , a relatively high frequency of 1MHz was applied to f_{IN} , in order to eliminate any error caused by the quiescent supply current.

Plastic DIP14 MECHANICAL DATA

DIM.	mm			inch		
	MIN.	TYP.	MAX.	MIN.	TYP.	MAX.
a1	0.51			0.020		
B	1.39		1.65	0.055		0.065
b		0.5			0.020	
b1		0.25			0.010	
D			20			0.787
E		8.5			0.335	
e		2.54			0.100	
e3		15.24			0.600	
F			7.1			0.280
I			5.1			0.201
L		3.3			0.130	
Z	1.27		2.54	0.050		0.100

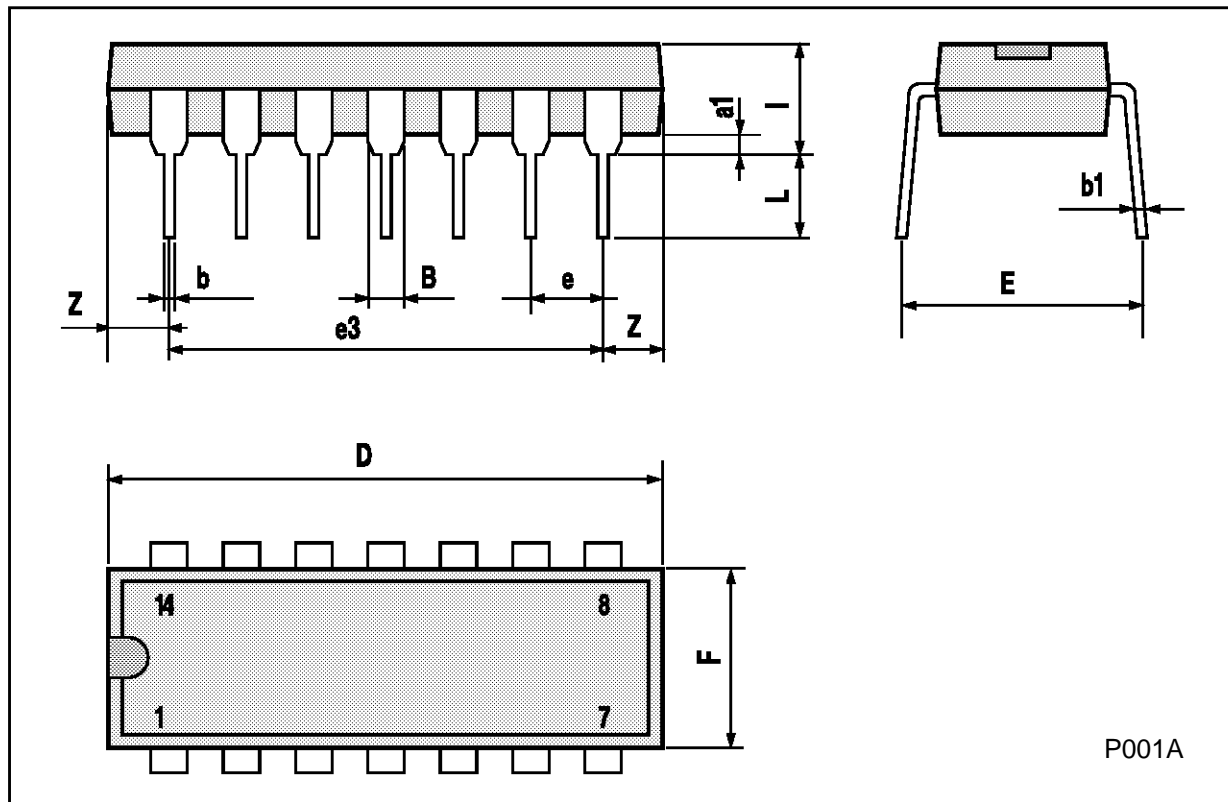

Ceramic DIP14/1 MECHANICAL DATA

DIM.	mm			inch		
	MIN.	TYP.	MAX.	MIN.	TYP.	MAX.
A			20			0.787
B			7.0			0.276
D		3.3			0.130	
E	0.38			0.015		
e3		15.24			0.600	
F	2.29		2.79	0.090		0.110
G	0.4		0.55	0.016		0.022
H	1.17		1.52	0.046		0.060
L	0.22		0.31	0.009		0.012
M	1.52		2.54	0.060		0.100
N			10.3			0.406
P	7.8		8.05	0.307		0.317
Q			5.08			0.200

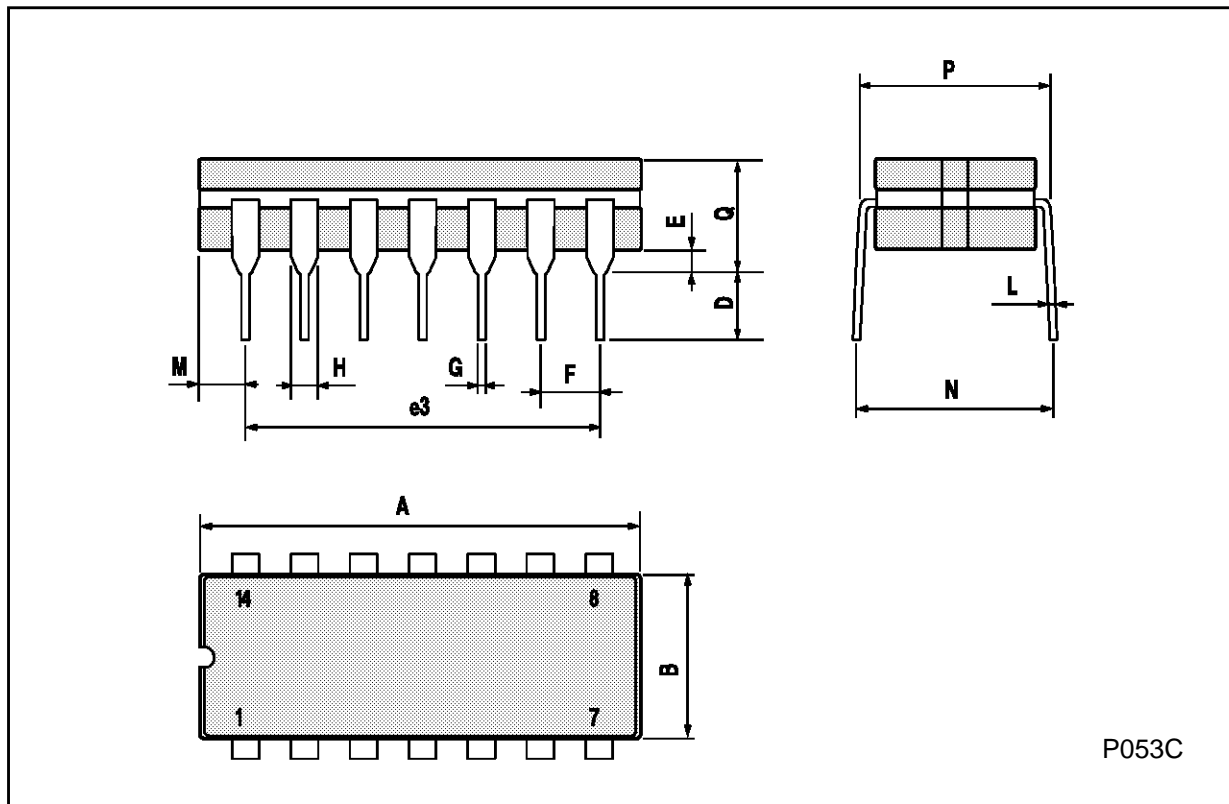

P053C

SO14 MECHANICAL DATA

DIM.	mm			inch		
	MIN.	TYP.	MAX.	MIN.	TYP.	MAX.
A			1.75			0.068
a1	0.1		0.2	0.003		0.007
a2			1.65			0.064
b	0.35		0.46	0.013		0.018
b1	0.19		0.25	0.007		0.010
C		0.5			0.019	
c1	45° (typ.)					
D	8.55		8.75	0.336		0.344
E	5.8		6.2	0.228		0.244
e		1.27			0.050	
e3		7.62			0.300	
F	3.8		4.0	0.149		0.157
G	4.6		5.3	0.181		0.208
L	0.5		1.27	0.019		0.050
M			0.68			0.026
S	8° (max.)					

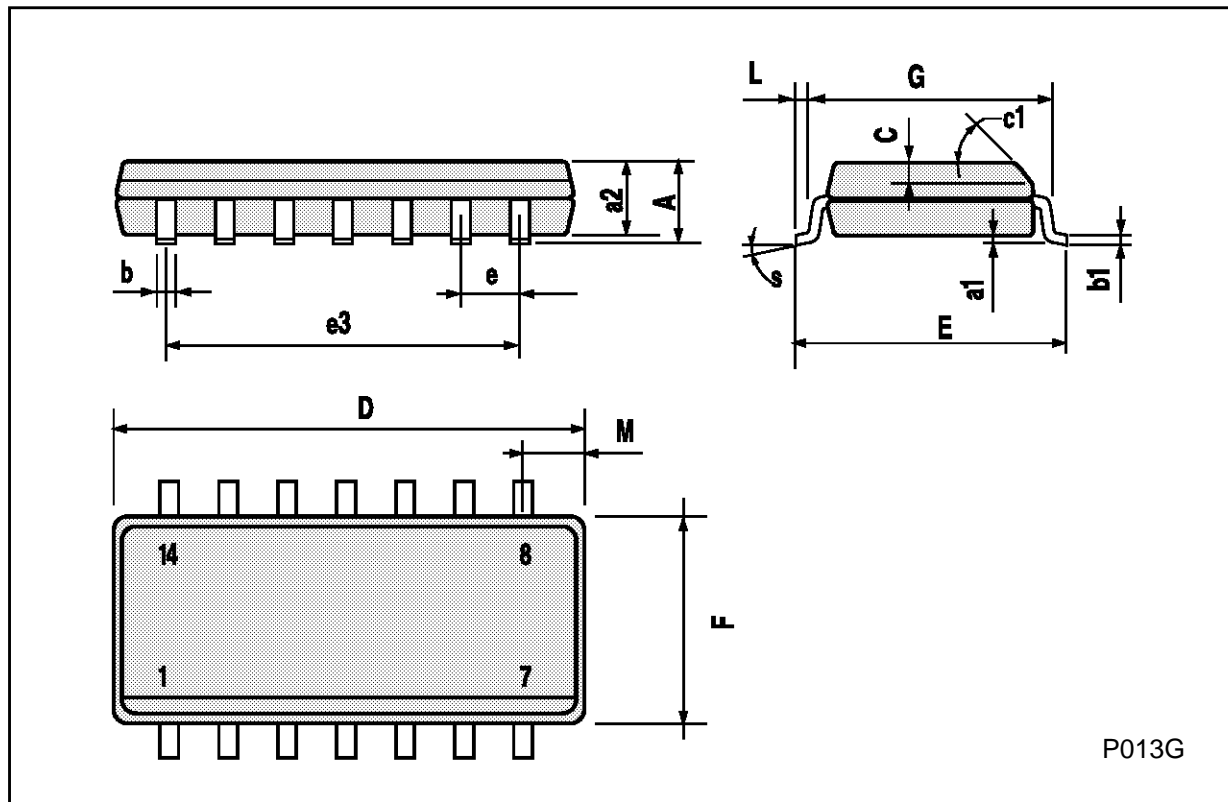

PLCC20 MECHANICAL DATA

DIM.	mm			inch		
	MIN.	TYP.	MAX.	MIN.	TYP.	MAX.
A	9.78		10.03	0.385		0.395
B	8.89		9.04	0.350		0.356
D	4.2		4.57	0.165		0.180
d1		2.54			0.100	
d2		0.56			0.022	
E	7.37		8.38	0.290		0.330
e		1.27			0.050	
e3		5.08			0.200	
F		0.38			0.015	
G			0.101			0.004
M		1.27			0.050	
M1		1.14			0.045	



Information furnished is believed to be accurate and reliable. However, SGS-THOMSON Microelectronics assumes no responsibility for the consequences of use of such information nor for any infringement of patents or other rights of third parties which may result from its use. No license is granted by implication or otherwise under any patent or patent rights of SGS-THOMSON Microelectronics. Specifications mentioned in this publication are subject to change without notice. This publication supersedes and replaces all information previously supplied. SGS-THOMSON Microelectronics products are not authorized for use as critical components in life support devices or systems without express written approval of SGS-THOMSON Microelectronics.

© 1994 SGS-THOMSON Microelectronics - All Rights Reserved

SGS-THOMSON Microelectronics GROUP OF COMPANIES

Australia - Brazil - France - Germany - Hong Kong - Italy - Japan - Korea - Malaysia - Malta - Morocco - The Netherlands -
Singapore - Spain - Sweden - Switzerland - Taiwan - Thailand - United Kingdom - U.S.A



LittleDiode supplies new, hard to find or obsolete electronic components and semiconductors all over the world.

With over two million different components listed you are sure to find the part you need.

Feel free to visit us today at our online store:

LittleDiode.com

Looking forward to providing you with the best possible service.