

DATA SHEET

For a complete data sheet, please also download:

- The IC06 74HC/HCT/HCU/HCMOS Logic Family Specifications
- The IC06 74HC/HCT/HCU/HCMOS Logic Package Information
- The IC06 74HC/HCT/HCU/HCMOS Logic Package Outlines

74HC/HCT533

**Octal D-type transparent latch;
3-state; inverting**

Product specification
File under Integrated Circuits, IC06

December 1990

Octal D-type transparent latch; 3-state; inverting

74HC/HCT533

FEATURES

- 3-state inverting outputs for bus oriented applications
- Common 3-state output enable input
- Output capability: bus driver
- I_{CC} category: MSI

GENERAL DESCRIPTION

The 74HC/HCT533 are high-speed Si-gate CMOS devices and are pin compatible with low power Schottky TTL (LSTTL). They are specified in compliance with JEDEC standard no. 7A.

The 74HC/HCT533 are octal D-type transparent latches featuring separate D-type inputs for each latch and 3-state outputs for bus oriented applications. A latch enable (LE) input and an output enable (\overline{OE}) input are common to all latches.

The "533" consists of eight D-type transparent latches with 3-state inverting outputs. When LE is HIGH, data at the D_n inputs enter the latches. In this condition the latches are transparent, i.e. a latch output will change state each time its corresponding D-input changes.

When LE is LOW the latches store the information that was present at the D-inputs a set-up time preceding the HIGH-to-LOW transition of LE.

When \overline{OE} is LOW, the contents of the 8 latches are available at the outputs.

When \overline{OE} is HIGH, the outputs go to the high impedance OFF-state. Operation of the \overline{OE} input does not affect the state of the latches.

The "533" is functionally identical to the "373", "563" and "573", but the "373" and "573" have non-inverted outputs and the "563" and "573" have a different pin arrangement.

QUICK REFERENCE DATA

GND = 0 V; $T_{amb} = 25\text{ }^\circ\text{C}$; $t_r = t_f = 6\text{ ns}$

SYMBOL	PARAMETER	CONDITIONS	TYPICAL		UNIT
			HC	HCT	
t_{PHL}/t_{PLH}	propagation delay	$C_L = 15\text{ pF}$; $V_{CC} = 5\text{ V}$			
	D_n to \overline{Q}_n		14	16	ns
	LE to \overline{Q}_n		18	19	ns
C_I	input capacitance		3.5	3.5	pF
C_{PD}	power dissipation capacitance per latch	notes 1 and 2	34	34	pF

Notes

1. C_{PD} is used to determine the dynamic power dissipation (P_D in μW):

$$P_D = C_{PD} \times V_{CC}^2 \times f_i + \sum (C_L \times V_{CC}^2 \times f_o) \text{ where:}$$

f_i = input frequency in MHz

f_o = output frequency in MHz

$\sum (C_L \times V_{CC}^2 \times f_o)$ = sum of outputs

C_L = output load capacitance in pF

V_{CC} = supply voltage in V

2. For HC the condition is $V_I = \text{GND to } V_{CC}$
For HCT the condition is $V_I = \text{GND to } V_{CC} - 1.5\text{ V}$

ORDERING INFORMATION

See "74HC/HCT/HCU/HCMOS Logic Package Information".

Octal D-type transparent latch; 3-state;
inverting

74HC/HCT533

PIN DESCRIPTION

PIN NO.	SYMBOL	NAME AND FUNCTION
1	\overline{OE}	3-state output enable input (active LOW)
2, 5, 6, 9, 12, 15, 16, 19	\overline{Q}_0 to \overline{Q}_7	3-state latch outputs
3, 4, 7, 8, 13, 14, 17, 18	D_0 to D_7	data inputs
10	GND	ground (0 V)
11	LE	latch enable input (active HIGH)
20	V_{CC}	positive supply voltage

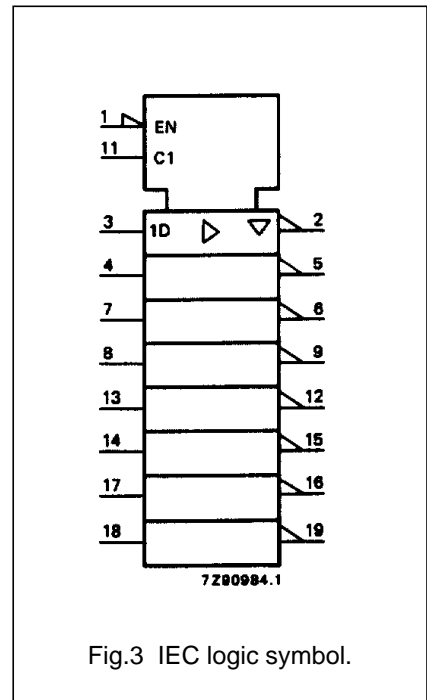
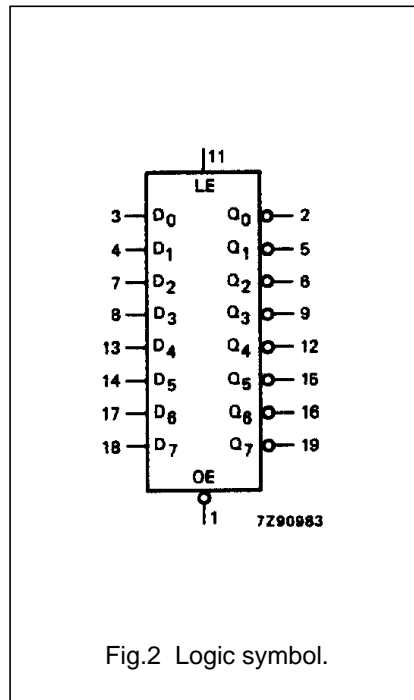
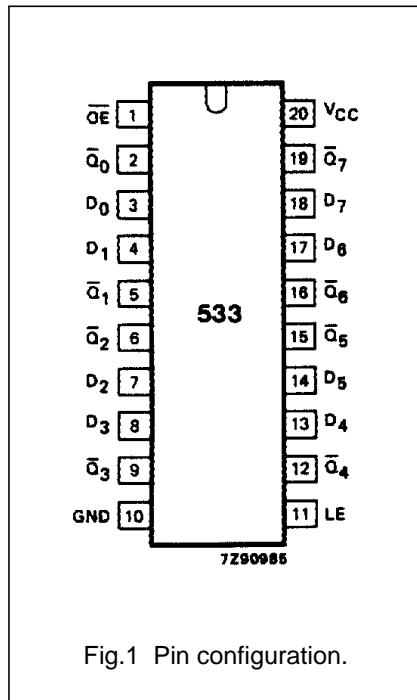

Octal D-type transparent latch; 3-state; inverting

74HC/HCT533

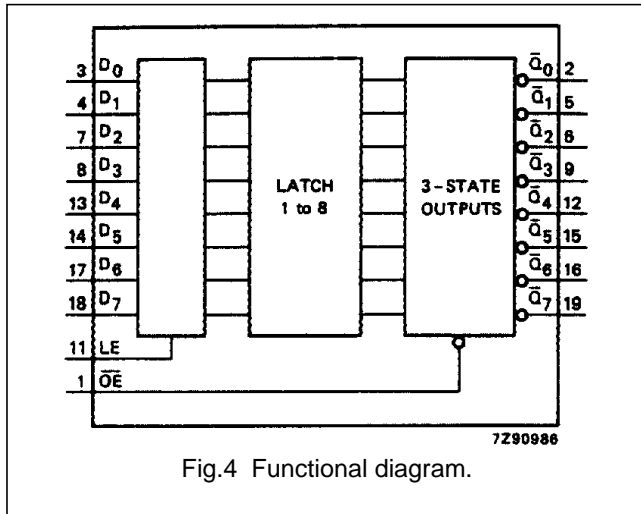

FUNCTION TABLE

OPERATING MODES	INPUTS			INTERNAL LATCHES	OUTPUTS \bar{Q}_0 TO \bar{Q}_7
	\overline{OE}	LE	D_n		
enable and read register (transparent mode)	L	H	L	L	H
enable and read register (transparent mode)	L	H	H	H	L
latch and read register	L	L	l	L	H
latch and read register	L	L	h	H	L
latch register and disable outputs	H	X	X	X	Z
latch register and disable outputs	H	X	X	X	Z

Notes

- H = HIGH voltage level
 h = HIGH voltage level one set-up prior to the HIGH-to-LOW LE transition
 L = LOW voltage level
 l = LOW voltage level one set-up prior to the HIGH-to-LOW LE transition
 X = don't care
 Z = high impedance OFF-state

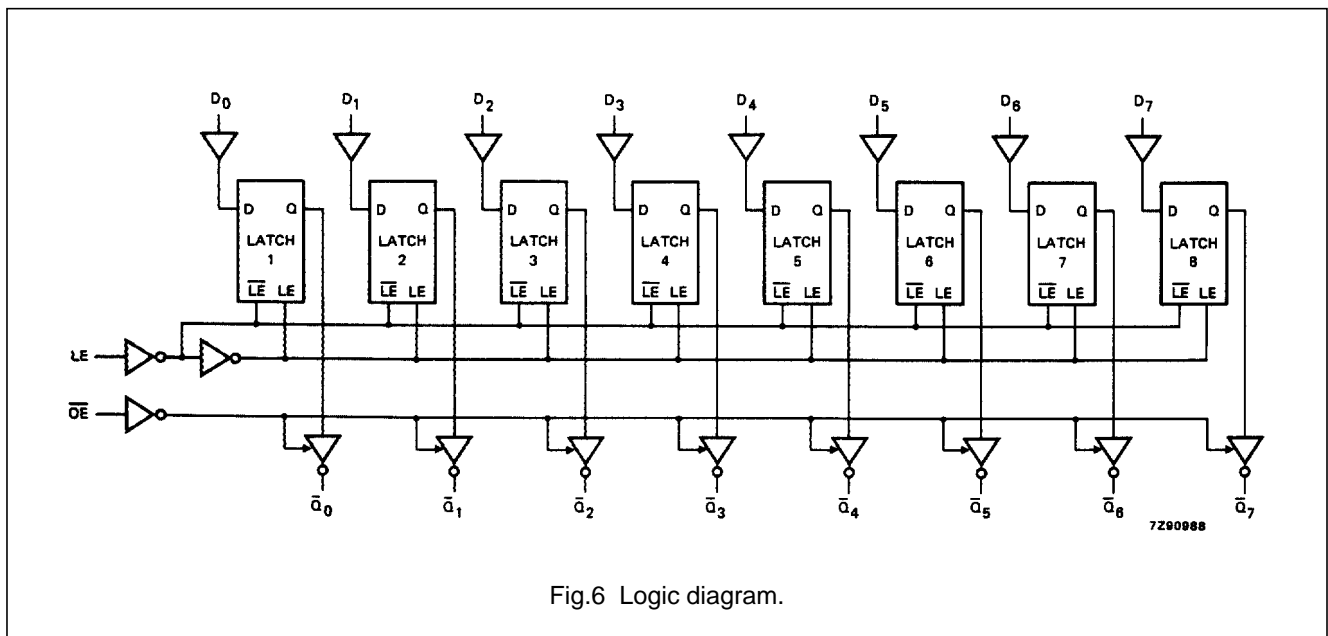
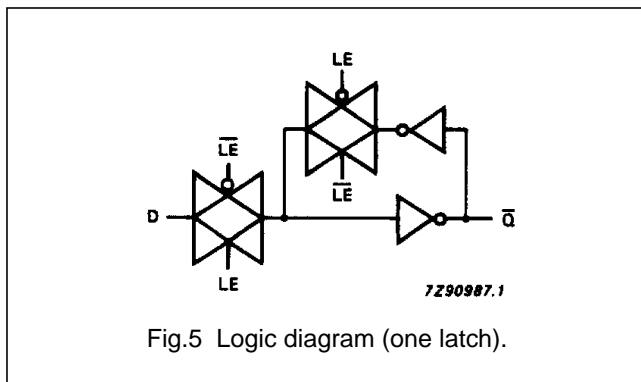

Octal D-type transparent latch; 3-state; inverting

74HC/HCT533

DC CHARACTERISTICS FOR 74HC

For the DC characteristics see *"74HC/HCT/HCU/HCMOS Logic Family Specifications"*.

Output capability: bus driver

I_{CC} category: MSI

AC CHARACTERISTICS FOR 74HC

GND = 0 V; t_r = t_f = 6 ns; C_L = 50 pF

SYMBOL	PARAMETER	T _{amb} (°C)						UNIT	TEST CONDITIONS		
		74HC							V _{CC} (V)	WAVEFORMS	
		+25			-40 to +85		-40 to +125				
		min.	typ.	max.	min.	max.	min.				max.
t _{PHL} / t _{PLH}	propagation delay D _n to \overline{Q}_n		47 17 14	150 30 26		190 38 33		225 45 38	ns	2.0 4.5 6.0	Fig.7
t _{PHL} / t _{PLH}	propagation delay LE to \overline{Q}_n		58 21 17	175 35 30		220 44 37		265 53 45	ns	2.0 4.5 6.0	Fig.8
t _{PZH} / t _{PZL}	3-state output enable time \overline{OE} to \overline{Q}_n		44 16 13	150 30 26		190 38 33		225 45 38	ns	2.0 4.5 6.0	Fig.9
t _{PHZ} / t _{PLZ}	3-state output disable time \overline{OE} to \overline{Q}_n		50 18 14	150 30 26		190 38 33		225 45 38	ns	2.0 4.5 6.0	Fig.9
t _{THL} / t _{TLH}	output transition time		14 5 4	60 12 10		75 15 13		90 18 15	ns	2.0 4.5 6.0	Fig.7
t _W	LE pulse width HIGH	80 16 14	14 5 4		100 20 17		120 24 20		ns	2.0 4.5 6.0	Fig.8
t _{SU}	set-up time D _n to LE	50 10 9	3 1 1		65 13 11		75 15 13		ns	2.0 4.5 6.0	Fig.10
t _H	hold time D _n to LE	35 7 6	3 1 1		45 9 8		55 11 9		ns	2.0 4.5 6.0	Fig.10

Octal D-type transparent latch; 3-state; inverting

74HC/HCT533

DC CHARACTERISTICS FOR 74HCT

For the DC characteristics see *"74HC/HCT/HCU/HCMOS Logic Family Specifications"*.

Output capability: bus driver

I_{CC} category: MSI

Note to HCT types

The value of additional quiescent supply current (ΔI_{CC}) for a unit load of 1 is given in the family specifications. To determine ΔI_{CC} per input, multiply this value by the unit load coefficient shown in the table below.

INPUT	UNIT LOAD COEFFICIENT
D _n	0.15
LE	0.30
\overline{OE}	0.55

AC CHARACTERISTICS FOR 74HCT

GND = 0 V; t_r = t_f = 6 ns; C_L = 50 pF

SYMBOL	PARAMETER	T _{amb} (°C)							UNIT	TEST CONDITIONS	
		74HCT								V _{CC} (V)	WAVEFORMS
		+25			-40 to +85		-40 to +125				
		min.	typ.	max.	min.	max.	min.	max.			
t _{PHL} / t _{PLH}	propagation delay D _n to \overline{Q}_n		19	34		43		51	ns	4.5	Fig.7
t _{PHL} / t _{PLH}	propagation delay LE to \overline{Q}_n		22	38		48		57	ns	4.5	Fig.8
t _{PZH} / t _{PZL}	3-state output enable time \overline{OE} to \overline{Q}_n		19	35		44		53	ns	4.5	Fig.9
t _{PHZ} / t _{PLZ}	3-state output disable time \overline{OE} to \overline{Q}_n		18	30		38		45	ns	4.5	Fig.9
t _{THL} / t _{TLH}	output transition time		5	12		15		18	ns	4.5	Fig.7
t _W	LE pulse width HIGH	16	5		20		24		ns	4.5	Fig.8
t _{SU}	set-up time D _n to LE	10	3		13		15		ns	4.5	Fig.10
t _H	hold time D _n to LE	8	2		10		12		ns	4.5	Fig.10

Octal D-type transparent latch; 3-state; inverting

74HC/HCT533

AC WAVEFORMS

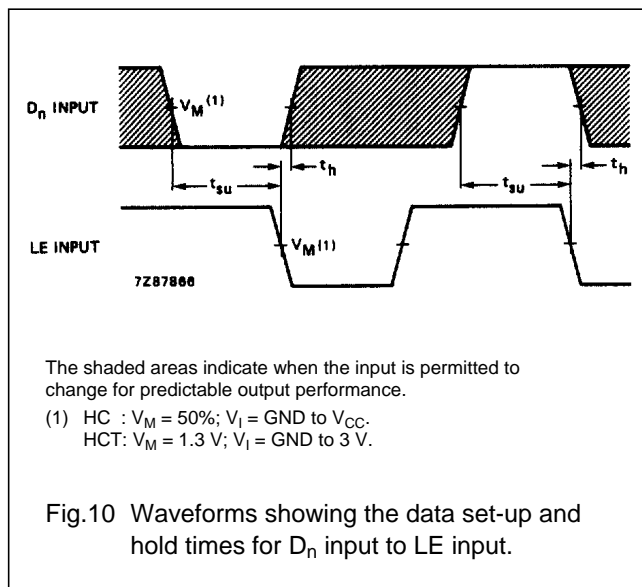
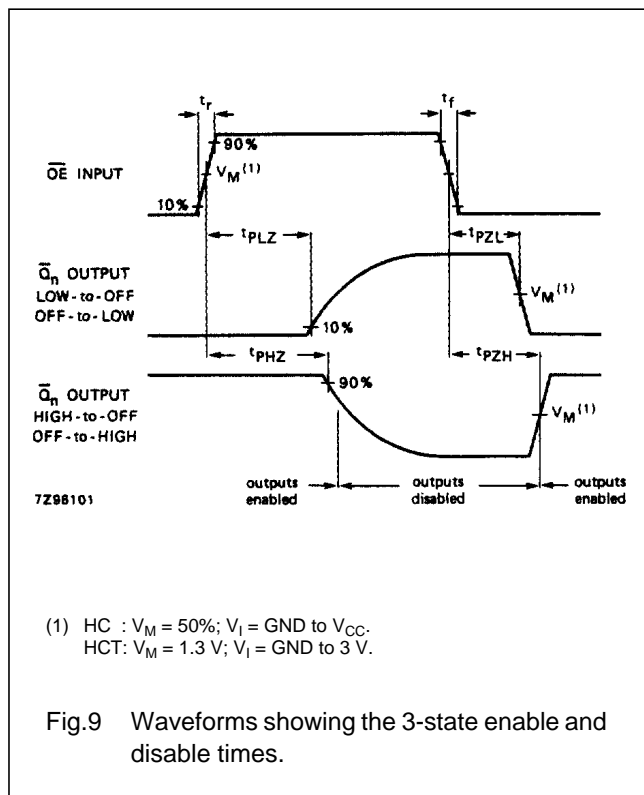
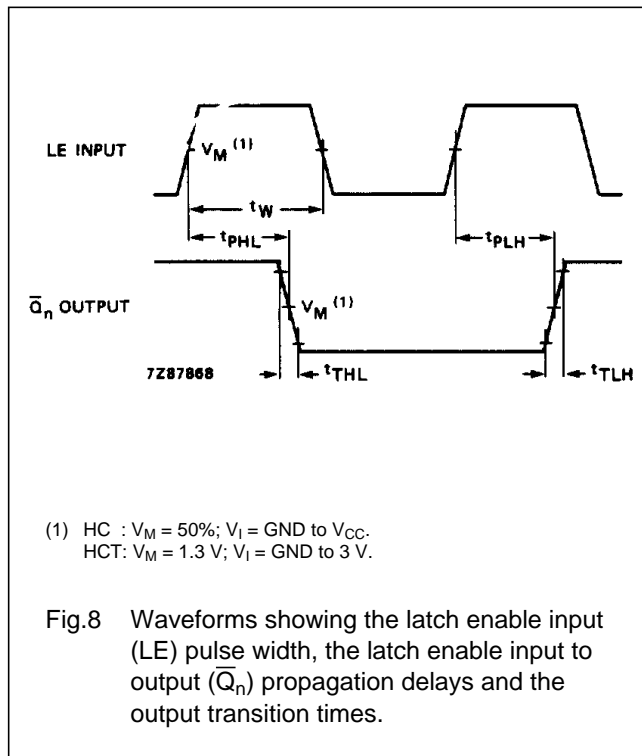
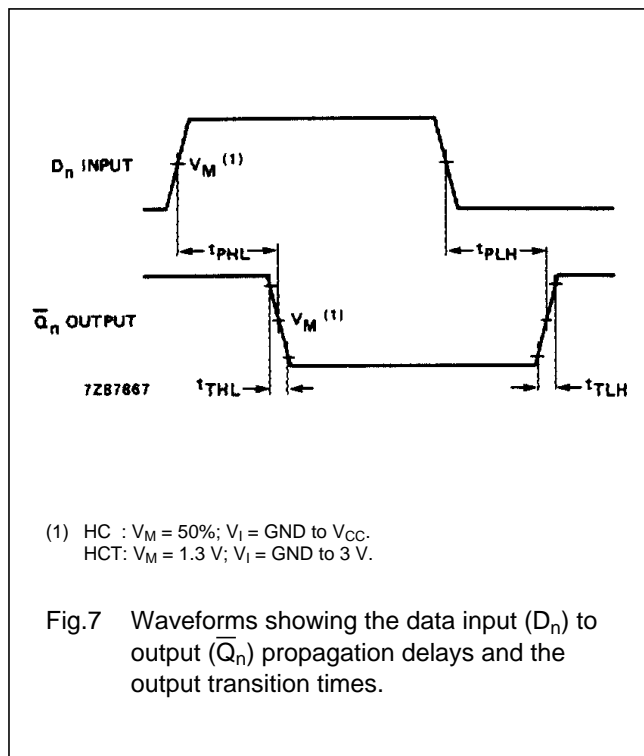

PACKAGE OUTLINES

See "74HC/HCT/HCU/HCMOS Logic Package Outlines".



LittleDiode supplies new, hard to find or obsolete electronic components and semiconductors all over the world.

With over two million different components listed you are sure to find the part you need.

Feel free to visit us today at our online store:

LittleDiode.com

Looking forward to providing you with the best possible service.