

# HD74HC590 • 8-bit Binary Counter/Register (with 3-state outputs)

This device each contains an 8-bit binary counter that feeds an 8-bit storage register. The storage register has parallel outputs. Separate clocks are provided for both the binary counter and storage register. The binary counter features a direct clear input  $\overline{\text{CCLR}}$  and a count enable input  $\overline{\text{CCKEN}}$ . For cascading a ripple carry output  $\overline{\text{RCO}}$  is provided. Expansion is easily accomplished by tying  $\overline{\text{RCO}}$  of the first stage to  $\overline{\text{CCKEN}}$  of the second stage, etc.

Both the counter and register clocks are positive-edge triggered. If the user wishes to connect both clocks together, the counter state will always be one count ahead of the register. Internal circuitry prevents clocking from the clock enable.

## FEATURES

- High Speed Operation
- High Output Current: Fanout of 15 LSTTL Loads
- Wide Operating Voltage:  $V_{CC}=2\sim 6V$
- Low Input Current:  $1\mu A$  max.
- Low Quiescent Supply Current:  $I_{CC}(\text{static})=4\mu A$  max. ( $T_a=25^\circ C$ )

## PIN ARRANGEMENT

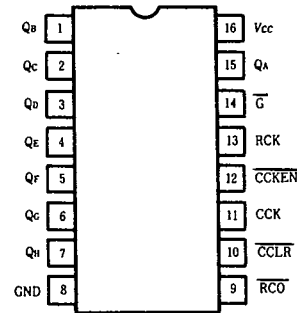

(Top View)

## FUNCTION TABLE

$\overline{\text{G}}$	Inputs				Function
	RCK	$\overline{\text{CCLR}}$	$\overline{\text{CCKEN}}$	CCK	
H	x	x	x	x	Q output disabled
L	x	x	x	x	Q output enabled
x		x	x	x	Contents of counter stored to register
x		x	x	x	No change in register
x	x	L	x	x	Counter Clear
x	x	H	L		Count Up
x	x	H	L		No count
x	x	H	H	x	No count

## LOGIC DIAGRAM

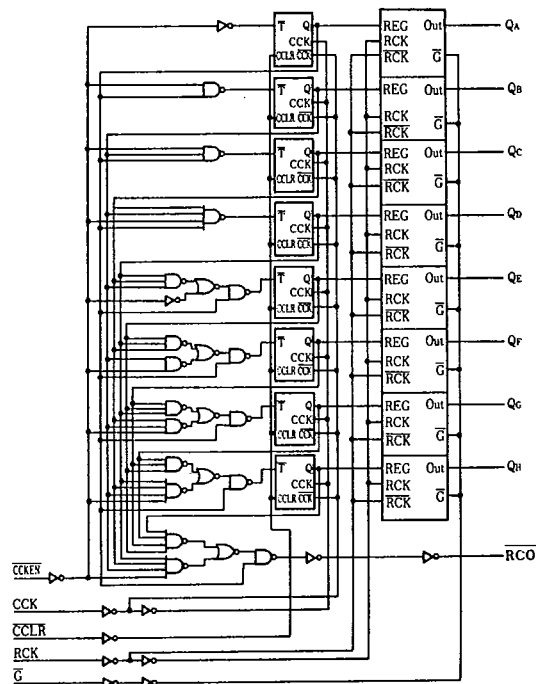

92D 10544 D

HD74HC590

T-45-23-17

**■ ABSOLUTE MAXIMUM RATINGS**

Item	Symbol	Rating	Unit
Supply Voltage Range	$V_{CC}$	-0.5~+7.0	V
Input Voltage	$V_{IH}$	-0.5~ $V_{CC}+0.5$	V
Output Voltage	$V_{OVT}$	-0.5~ $V_{CC}+0.5$	V
Output Current	$I_{OVT}$	±35	mA
DC Current Drain per $V_{CC}$ , GND	$I_{CC}, I_{GND}$	±75	mA
DC Input Diode Current	$I_{IK}$	±20	mA
DC Output Diode Current	$I_{OK}$	±20	mA
Power Dissipation per Package	$P_T$	500	mW
Storage Temperature	$T_{stg}$	-65~+150	°C

**■ DC CHARACTERISTICS**

Item	Symbol	$V_{CC}(V)$	Test Conditions	$T_a=25^\circ C$			$T_a=-40\sim+85^\circ C$		Unit			
				min.	typ.	max.	min.	max.				
Input Voltage	$V_{IH}$	2.0		1.5	-	-	1.5	-	V			
		4.5		3.15	-	-	3.15	-				
		6.0		4.2	-	-	4.2	-				
	$V_{IL}$	2.0		-	-	0.5	-	0.5	V			
		4.5		-	-	1.35	-	1.35				
		6.0		-	-	1.8	-	1.8				
Output Voltage	$V_{OH}$	2.0	$Q_A\sim Q_H$ $V_{in}=V_{IH}$ or $V_{IL}$	$I_{OH}=-20\mu A$	1.9	2.0	-	1.9	-	V		
		4.5			4.4	4.5	-	4.4	-			
		6.0			5.9	6.0	-	5.9	-			
		4.5		$I_{OH}=-6mA$	4.18	-	-	4.13	-			
					6.0	$I_{OH}=-7.8mA$	5.68	-	-		5.63	-
							-	-	-		-	-
	$V_{OL}$	$Q_A\sim Q_H$ $V_{in}=V_{IH}$ or $V_{IL}$	$I_{OL}=20\mu A$	2.0	-	0.0	0.1	-	0.1	V		
				4.5	-	0.0	0.1	-	0.1			
				6.0	-	0.0	0.1	-	0.1			
			4.5	$I_{OL}=6mA$	-	-	0.26	-	0.33			
					6.0	$I_{OL}=7.8mA$	-	-	0.26		-	0.33
							-	-	-		-	-
Output Voltage	$V_{OH}$	$\overline{RCO}$ $V_{in}=V_{IH}$ or $V_{IL}$	$I_{OH}=-20\mu A$	2.0	1.9	2.0	-	1.9	-	V		
				4.5	4.4	4.5	-	4.4	-			
				6.0	5.9	6.0	-	5.9	-			
			4.5	$I_{OH}=-4mA$	4.18	-	-	4.13	-			
					6.0	$I_{OH}=-5.2mA$	5.68	-	-		5.63	-
							-	-	-		-	-
	$V_{OL}$	$\overline{RCO}$ $V_{in}=V_{IH}$ or $V_{IL}$	$I_{OL}=20\mu A$	2.0	-	0.0	0.1	-	0.1	V		
				4.5	-	0.0	0.1	-	0.1			
				6.0	-	0.0	0.1	-	0.1			
			4.5	$I_{OL}=4mA$	-	-	0.26	-	0.33			
					6.0	$I_{OL}=5.2mA$	-	-	0.26		-	0.33
							-	-	-		-	-
Off-state Output Current	$I_{OZ}$	6.0	$V_{in}=V_{IH}$ or $V_{IL}, V_{out}=V_{CC}$ or GND	-	-	±0.5	-	±5.0	μA			
Input Current	$I_{in}$	6.0	$V_{in}=V_{CC}$ or GND	-	-	±0.1	-	±1.0	μA			
Quiescent Supply Current	$I_{CC}$	6.0	$V_{in}=V_{CC}$ or GND, $I_{out}=0\mu A$	-	-	4.0	-	40	μA			



92D 10545 D

T-45-23-17

HD74HC590

■ AC CHARACTERISTICS (  $C_L=50\text{pF}$ , Input  $t_r=t_f=6\text{ns}$  )

Item	Symbol	$V_{CC}(V)$	Test Conditions	$T_a=25^\circ\text{C}$			$T_a=-40\sim+85^\circ\text{C}$		Unit	
				min.	typ.	max.	min.	max.		
Maximum Clock Frequency	$f_{max}$	2.0		-	-	5	-	4	MHz	
		4.5		-	-	25	-	20		
		6.0		-	-	29	-	24		
Propagation Delay Time	$t_{PLH}$ $t_{PHL}$	2.0	CCK to $\overline{\text{RCO}}$	-	-	200	-	250	ns	
		4.5		-	-	40	-	50		
		6.0		-	-	34	-	43		
	$t_{PLH}$	2.0	$\overline{\text{CCLR}}$ to $\overline{\text{RCO}}$	-	-	250	-	315	ns	
		4.5		-	-	50	-	63		
		6.0		-	-	43	-	54		
	$t_{PLH}$ $t_{PHL}$	2.0	RCK to Q	-	-	200	-	250	ns	
		4.5		-	-	40	-	50		
		6.0		-	-	34	-	43		
Output Enable Time	$t_{ZL}$ $t_{ZH}$	2.0		-	-	150	-	190	ns	
		4.5		-	-	30	-	39		
		6.0		-	-	26	-	33		
Output Disable Time	$t_{LZ}$ $t_{HZ}$	2.0		-	-	150	-	190	ns	
		4.5		-	-	30	-	38		
		6.0		-	-	26	-	33		
Pulse Width	$t_w$	2.0		80	-	-	100	-	ns	
		4.5		16	-	-	20	-		
		6.0		14	-	-	17	-		
Removal Time	$t_{rem}$	2.0	$\overline{\text{CCKEN}}$ to CCK	100	-	-	125	-	ns	
		4.5		20	-	-	25	-		
		6.0		17	-	-	21	-		
Setup Time	$t_{su}$	2.0	$\overline{\text{CCLR}}$ to CCK	100	-	-	125	-	ns	
		4.5		20	-	-	25	-		
		6.0		17	-	-	21	-		
		$t_{su}$	2.0	CCK to RCK	200	-	-	250	-	ns
			4.5		40	-	-	50	-	
			6.0		34	-	-	43	-	
Output Rise/Fall Time	$t_{TLH}$ $t_{THL}$	2.0	Q	-	-	60	-	75	ns	
		4.5		-	-	12	-	15		
		6.0		-	-	10	-	13		
		$t_{TLH}$ $t_{THL}$	2.0	$\overline{\text{RCO}}$	-	-	75	-	95	ns
			4.5		-	-	15	-	19	
			6.0		-	-	13	-	16	
Input Capacitance	$C_{in}$	-		-	5	10	-	10	pF	

# PACKAGE INFORMATION

T-90-20

In the HD74HC series of HS-CMOS logic, either of plastic DIP and small outline packages can be selected.  
For your ordering, please refer to the following package code.

● Package code of HS-CMOS Logic

## HD74HC XXXXP

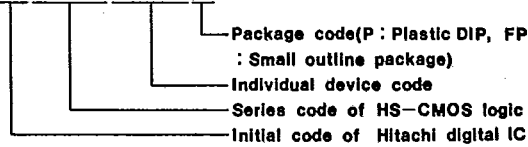

### ■ PLASTIC DIP PACKAGE [Unit: mm (inch), scale: 1/1]

● 14-pin type

● 16-pin type

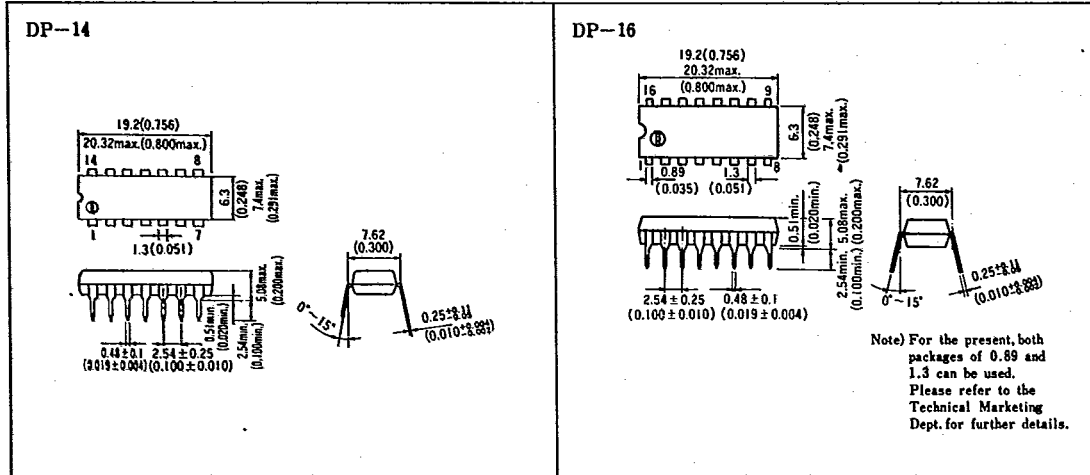

● 20-pin type

● 24-pin type

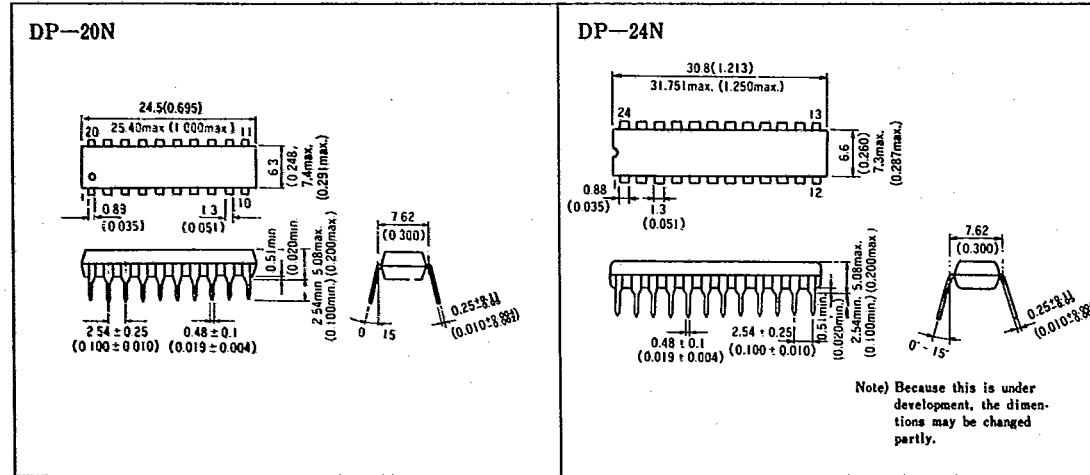

SMALL OUTLINE PACKAGE [Unit: mm (inch), scale: 1 1/2]

●14-pin type

●16-pin type

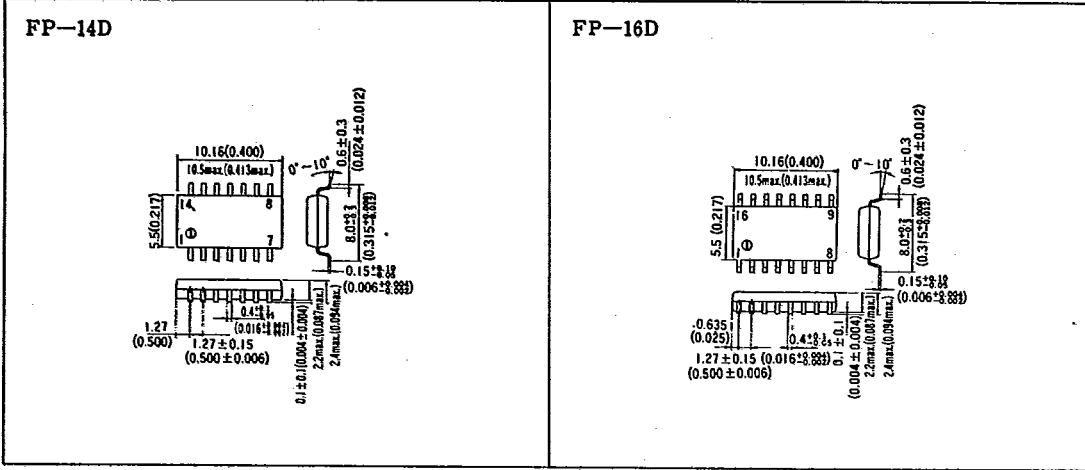

●20-pin type

