

# DATA SHEET

For a complete data sheet, please also download:

- The IC06 74HC/HCT/HCU/HCMOS Logic Family Specifications
- The IC06 74HC/HCT/HCU/HCMOS Logic Package Information
- The IC06 74HC/HCT/HCU/HCMOS Logic Package Outlines

## **74HC/HCT4017**

Johnson decade counter with 10  
decoded outputs

Product specification  
File under Integrated Circuits, IC06

December 1990

# Johnson decade counter with 10 decoded outputs

# 74HC/HCT4017

## FEATURES

- Output capability: standard
- I<sub>CC</sub> category: MSI

## GENERAL DESCRIPTION

The 74HC/HCT4017 are high-speed Si-gate CMOS devices and are pin compatible with the “4017” of the “4000B” series. They are specified in compliance with JEDEC standard no. 7A.

The 74HC/HCT4017 are 5-stage Johnson decade counters with 10 decoded active HIGH outputs (Q<sub>0</sub> to Q<sub>9</sub>), an active LOW output from the most significant flip-flop ( $\overline{Q}_{5-9}$ ), active HIGH and active LOW clock inputs (CP<sub>0</sub> and

$\overline{CP}_1$ ) and an overriding asynchronous master reset input (MR).

The counter is advanced by either a LOW-to-HIGH transition at CP<sub>0</sub> while  $\overline{CP}_1$  is LOW or a HIGH-to-LOW transition at  $\overline{CP}_1$  while CP<sub>0</sub> is HIGH (see also function table).

When cascading counters, the  $\overline{Q}_{5-9}$  output, which is LOW while the counter is in states 5, 6, 7, 8 and 9, can be used to drive the CP<sub>0</sub> input of the next counter.

A HIGH on MR resets the counter to zero (Q<sub>0</sub> =  $\overline{Q}_{5-9}$  = HIGH; Q<sub>1</sub> to Q<sub>9</sub> = LOW) independent of the clock inputs (CP<sub>0</sub> and  $\overline{CP}_1$ ).

Automatic code correction of the counter is provided by an internal circuit: following any illegal code the counter returns to a proper counting mode within 11 clock pulses.

## QUICK REFERENCE DATA

GND = 0 V; T<sub>amb</sub> = 25 °C; t<sub>r</sub> = t<sub>f</sub> = 6 ns

SYMBOL	PARAMETER	CONDITIONS	TYPICAL		UNIT
			HC	HCT	
t <sub>PHL</sub> / t <sub>PLH</sub>	propagation delay CP <sub>0</sub> , $\overline{CP}_1$ to Q <sub>n</sub>	C <sub>L</sub> = 15 pF; V <sub>CC</sub> = 5 V	20	21	ns
f <sub>max</sub>	maximum clock frequency		77	67	MHz
C <sub>I</sub>	input capacitance		3.5	3.5	pF
C <sub>PD</sub>	power dissipation capacitance per package	notes 1 and 2	35	36	pF

## Notes

1. C<sub>PD</sub> is used to determine the dynamic power dissipation (P<sub>D</sub> in μW):

$$P_D = C_{PD} \times V_{CC}^2 \times f_i + \sum (C_L \times V_{CC}^2 \times f_o) \text{ where:}$$

f<sub>i</sub> = input frequency in MHz

f<sub>o</sub> = output frequency in MHz

∑ (C<sub>L</sub> × V<sub>CC</sub><sup>2</sup> × f<sub>o</sub>) = sum of outputs

C<sub>L</sub> = output load capacitance in pF

V<sub>CC</sub> = supply voltage in V

2. For HC the condition is V<sub>I</sub> = GND to V<sub>CC</sub>

For HCT the condition is V<sub>I</sub> = GND to V<sub>CC</sub> – 1.5 V

## ORDERING INFORMATION

See “74HC/HCT/HCU/HCMOS Logic Package Information”.

Johnson decade counter with 10 decoded outputs

74HC/HCT4017

PIN DESCRIPTION

PIN NO.	SYMBOL	NAME AND FUNCTION
3, 2, 4, 7, 10, 1, 5, 6, 9, 11	Q <sub>0</sub> to Q <sub>9</sub>	decoded outputs
8	GND	ground (0 V)
12	$\overline{Q}_{5-9}$	carry output (active LOW)
13	$\overline{CP}_1$	clock input (HIGH-to-LOW, edge-triggered)
14	CP <sub>0</sub>	clock input (LOW-to-HIGH, edge-triggered)
15	MR	master reset input (active HIGH)
16	V <sub>CC</sub>	positive supply voltage

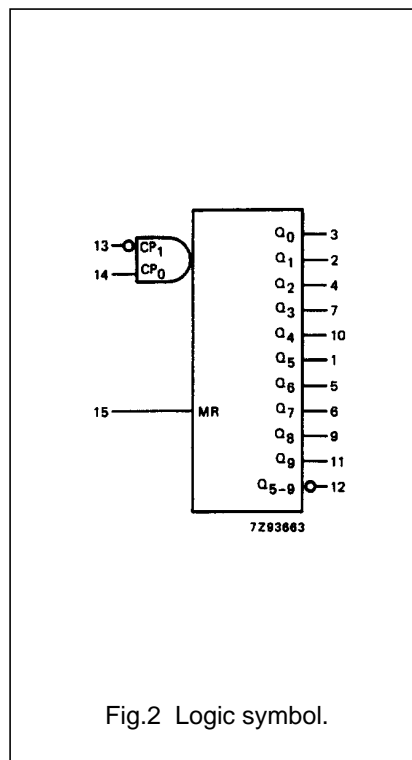
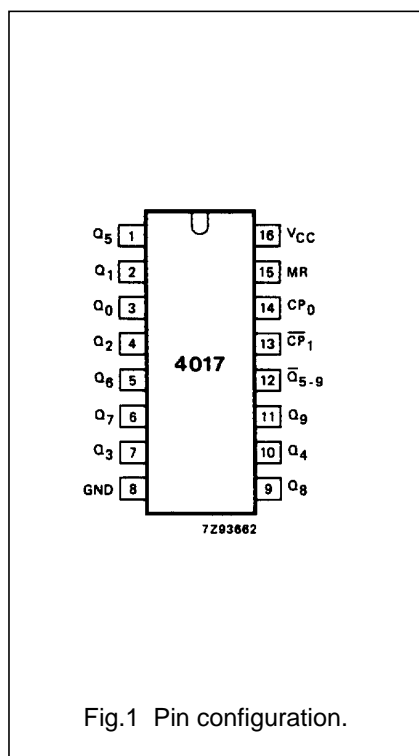

Johnson decade counter with 10 decoded outputs

74HC/HCT4017

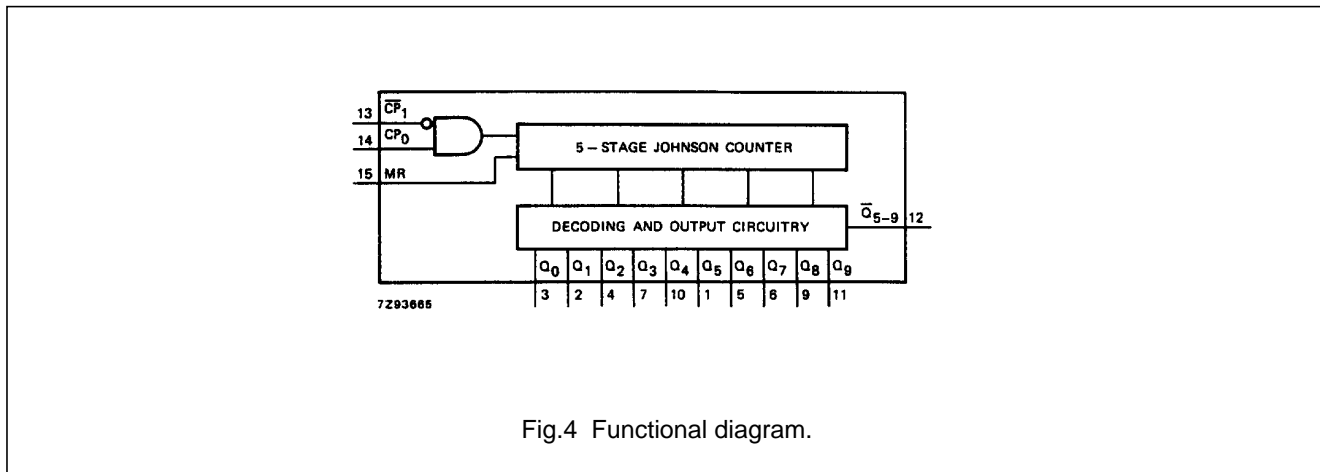

**FUNCTION TABLE**

MR	CP <sub>0</sub>	$\overline{CP}_1$	OPERATION
H	X	X	Q <sub>0</sub> = Q <sub>5-9</sub> = H; Q <sub>1</sub> to Q <sub>9</sub> = L
L	H	↓	counter advances
L	↑	L	counter advances
L	L	X	no change
L	X	H	no change
L	H	↑	no change
L	↓	L	no change

**Notes**

- H = HIGH voltage level  
 L = LOW voltage level  
 X = don't care  
 ↑ = LOW-to-HIGH clock transition  
 ↓ = HIGH-to-LOW clock transition



Johnson decade counter with 10 decoded outputs

74HC/HCT4017

---

**DC CHARACTERISTICS FOR 74HC**

For the DC characteristics see *"74HC/HCT/HCU/HCMOS Logic Family Specifications"*.

Output capability: standard

I<sub>CC</sub> category: MSI

## Johnson decade counter with 10 decoded outputs

## 74HC/HCT4017

## AC CHARACTERISTICS FOR 74HC

GND = 0 V;  $t_r = t_f = 6$  ns;  $C_L = 50$  pF

SYMBOL	PARAMETER	$T_{amb}$ (°C)						UNIT	TEST CONDITIONS		
		74HC							$V_{CC}$ (V)	WAVEFORMS	
		+25			-40 to+85		-40 to+125				
		min.	typ.	max.	min.	max.	min.				max.
$t_{PHL}/t_{PLH}$	propagation delay CP <sub>0</sub> to Q <sub>n</sub>		63 23 18	230 46 39		290 58 49		345 69 59	ns	2.0 4.5 6.0	Fig.9
$t_{PHL}/t_{PLH}$	propagation delay CP <sub>0</sub> to $\overline{Q}_{5-9}$		63 23 18	230 46 39		290 58 49		345 69 59	ns	2.0 4.5 6.0	Fig.9
$t_{PHL}/t_{PLH}$	propagation delay $\overline{CP}_1$ to Q <sub>n</sub>		61 22 18	250 50 43		315 63 54		375 75 64	ns	2.0 4.5 6.0	Fig.9
$t_{PHL}/t_{PLH}$	propagation delay $\overline{CP}_1$ to $\overline{Q}_{5-9}$		61 22 18	250 50 43		315 63 54		375 75 64	ns	2.0 4.5 6.0	Fig.9
$t_{PHL}$	propagation delay MR to Q <sub>1-9</sub>		52 19 15	230 46 39		290 58 49		345 69 59	ns	2.0 4.5 6.0	Fig.8
$t_{PLH}$	propagation delay MR to $\overline{Q}_{5-9}$ , Q <sub>0</sub>		55 20 16	230 46 39		290 58 49		345 69 59	ns	2.0 4.5 6.0	Fig.8
$t_{THL}/t_{TLH}$	output transition time		19 7 6	75 15 13		95 19 16		110 22 19	ns	2.0 4.5 6.0	Fig.9
$t_W$	clock pulse width HIGH or LOW	80 16 14	17 6 5		100 20 17		120 24 20		ns	2.0 4.5 6.0	Fig.8
$t_W$	master reset pulse width; HIGH	80 16 14	19 7 6		100 20 17		120 24 20		ns	2.0 4.5 6.0	Fig.8
$t_{rem}$	removal time MR to CP <sub>0</sub> , $\overline{CP}_1$	5 5 5	-17 -6 -5		5 5 5		5 5 5		ns	2.0 4.5 6.0	Fig.8
$t_{su}$	set-up time $\overline{CP}_1$ to CP <sub>0</sub> ; CP <sub>0</sub> to $\overline{CP}_1$	50 10 9	-8 -3 -2		65 13 11		75 15 13		ns	2.0 4.5 6.0	Fig.7
$t_h$	hold time CP <sub>0</sub> to $\overline{CP}_1$ ; $\overline{CP}_1$ to CP <sub>0</sub>	50 10 9	17 6 5		65 13 11		75 15 13		ns	2.0 4.5 6.0	Fig.7
$f_{max}$	maximum clock pulse frequency	6.0 30 25	23 70 83		4.8 24 28		4.0 20 24		MHz	2.0 4.5 6.0	Fig.8

## Johnson decade counter with 10 decoded outputs

74HC/HCT4017

**DC CHARACTERISTICS FOR 74HCT**

For the DC characteristics see *"74HC/HCT/HCU/HCMOS Logic Family Specifications"*.

Output capability: standard

I<sub>CC</sub> category: MSI

**Note to HCT types**

The value of additional quiescent supply current ( $\Delta I_{CC}$ ) for a unit load of 1 is given in the family specifications.

To determine  $\Delta I_{CC}$  per input, multiply this value by the unit load coefficient shown in the table below.

INPUT	UNIT LOAD COEFFICIENT
$\overline{CP}_1$	0.40
CP <sub>0</sub>	0.25
MR	0.50

## Johnson decade counter with 10 decoded outputs

## 74HC/HCT4017

## AC CHARACTERISTICS FOR 74HCT

GND = 0 V;  $t_r = t_f = 6$  ns;  $C_L = 50$  pF

SYMBOL	PARAMETER	$T_{amb}$ (°C)						UNIT	TEST CONDITIONS		
		74HCT							$V_{CC}$ (V)	WAVEFORMS	
		+25			-40 to+85		-40 to+125				
		min.	typ.	max.	min.	max.	min.				max.
$t_{PHL}/t_{PLH}$	propagation delay CP <sub>0</sub> to Q <sub>n</sub>		25	46		58		69	ns	4.5	Fig.9
$t_{PHL}/t_{PLH}$	propagation delay CP <sub>0</sub> to Q <sub>5-9</sub>		25	46		58		69	ns	4.5	Fig.9
$t_{PHL}/t_{PLH}$	propagation delay $\overline{CP}_1$ to Q <sub>n</sub>		25	50		63		75	ns	4.5	Fig.9
$t_{PHL}/t_{PLH}$	propagation delay $\overline{CP}_1$ to Q <sub>5-9</sub>		25	50		63		75	ns	4.5	Fig.9
$t_{PHL}$	propagation delay MR to Q <sub>1-9</sub>		22	46		58		69	ns	4.5	Fig.8
$t_{PLH}$	propagation delay MR to Q <sub>5-9</sub> , Q <sub>0</sub>		20	46		58		69	ns	4.5	Fig.8
$t_{THL}/t_{TLH}$	output transition time		7	15		19		22	ns	4.5	Fig.9
$t_W$	clock pulse width HIGH or LOW	16	7		20		24		ns	4.5	Fig.8
$t_W$	master reset pulse width; HIGH	16	4		20		24		ns	4.5	Fig.8
$t_{rem}$	removal time MR to CP <sub>0</sub> , $\overline{CP}_1$	5	-5		5		5		ns	4.5	Fig.8
$t_{su}$	set-up time $\overline{CP}_1$ to CP <sub>0</sub> ; CP <sub>0</sub> to $\overline{CP}_1$	10	-3		13		15		ns	4.5	Fig.7
$t_h$	hold time CP <sub>0</sub> to $\overline{CP}_1$ ; $\overline{CP}_1$ to CP <sub>0</sub>	10	6		13		15		ns	4.5	Fig.7
$f_{max}$	maximum clock pulse frequency	30	61		24		20		ns	4.5	Fig.8

Johnson decade counter with 10 decoded outputs

74HC/HCT4017

AC WAVEFORMS

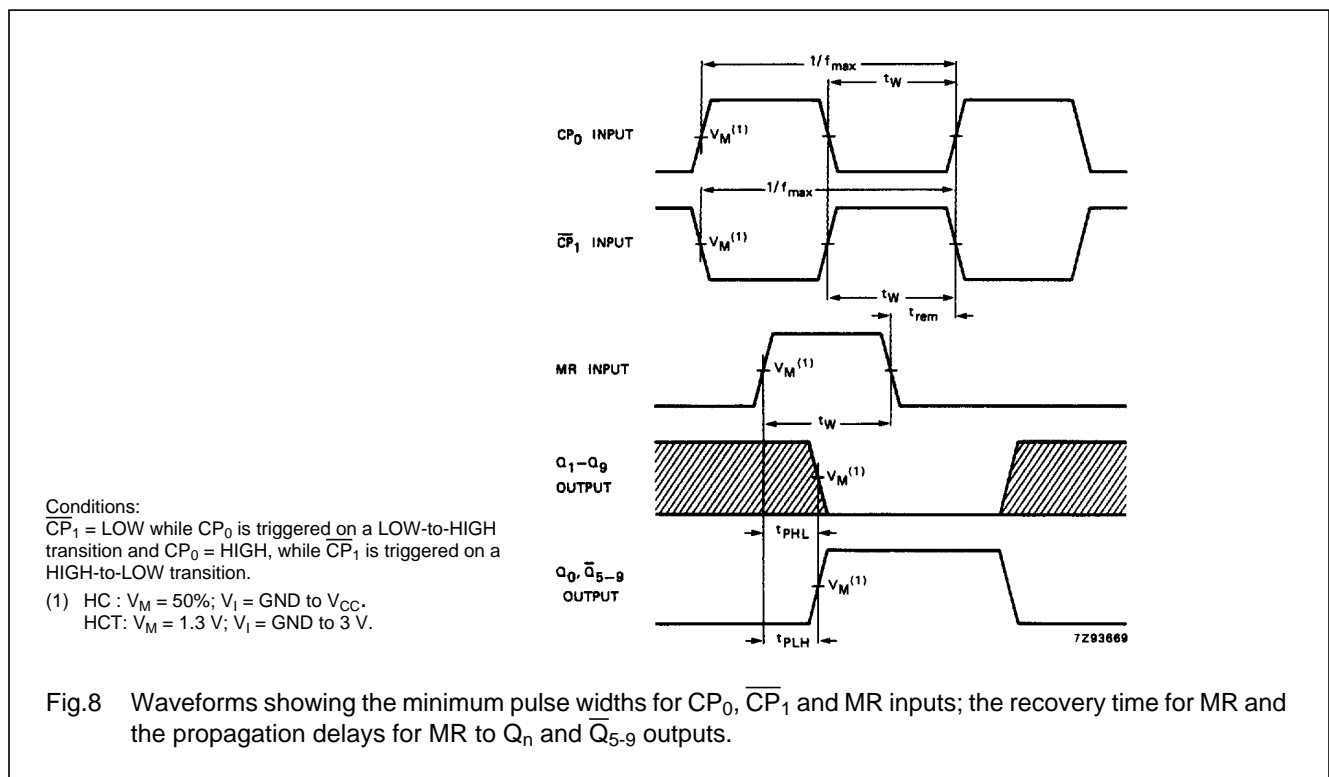
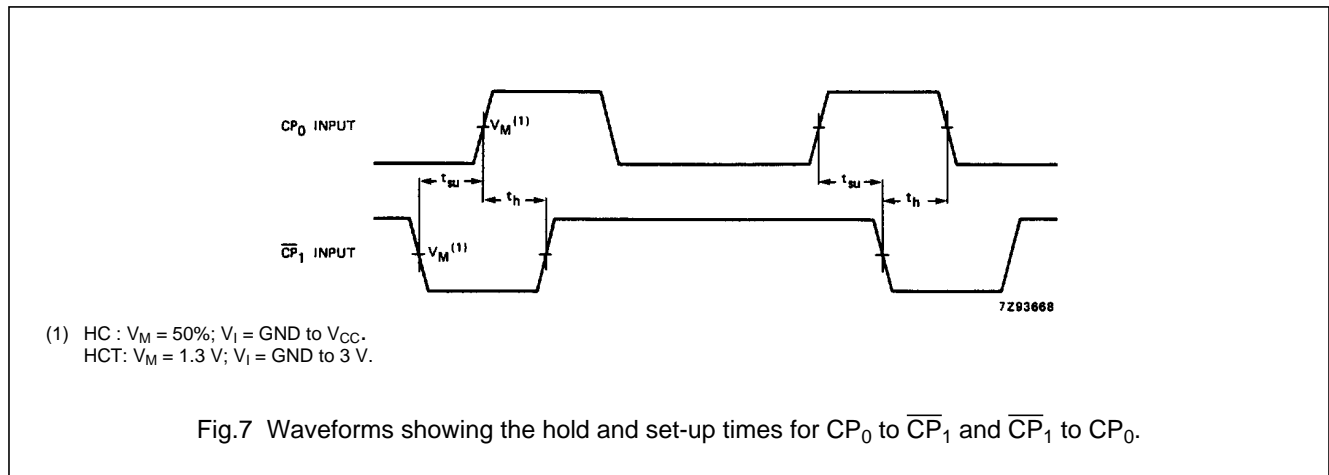

Johnson decade counter with 10 decoded outputs

74HC/HCT4017

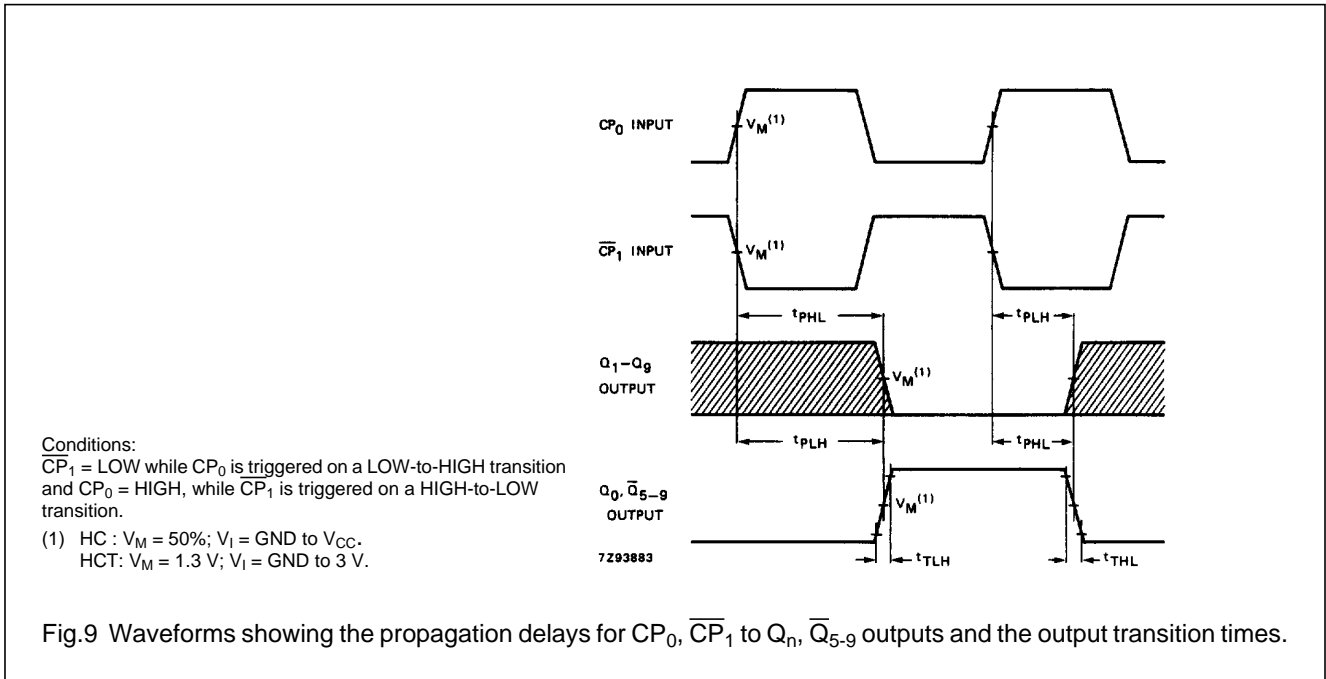

Fig.9 Waveforms showing the propagation delays for  $CP_0$ ,  $\overline{CP}_1$  to  $Q_n$ ,  $\overline{Q}_{5-9}$  outputs and the output transition times.

# Johnson decade counter with 10 decoded outputs

# 74HC/HCT4017

## APPLICATION INFORMATION

Some applications for the “4017” are:

- Decade counter with decimal decoding
- 1 out of n decoding counter (when cascaded)
- Sequential controller
- Timer

Figure 10 shows a technique for extending the number of decoded output states for the “4017”. Decoded outputs are sequential within each stage and from stage to stage, with no dead time (except propagation delay).

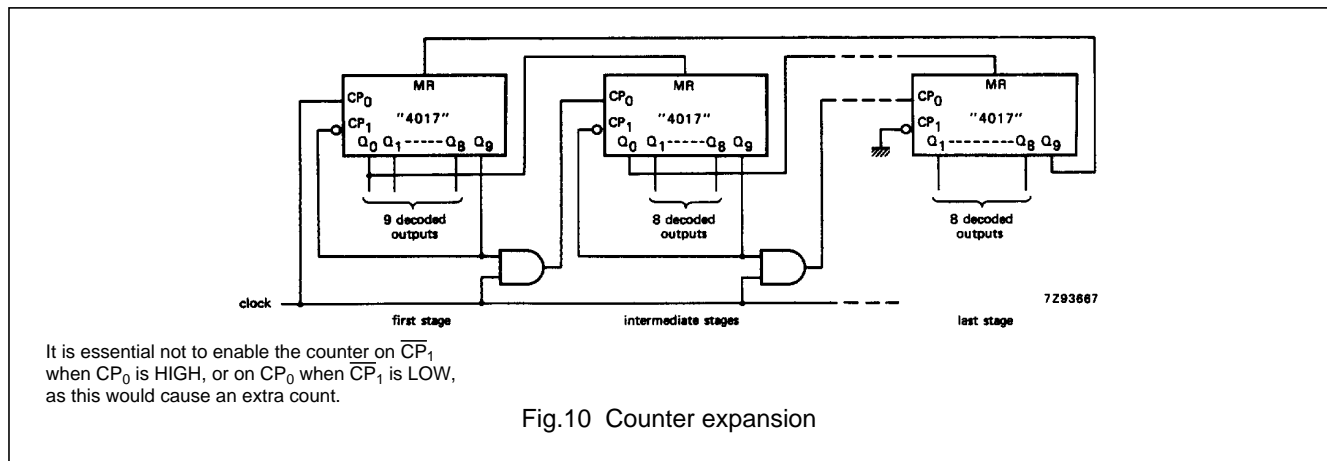
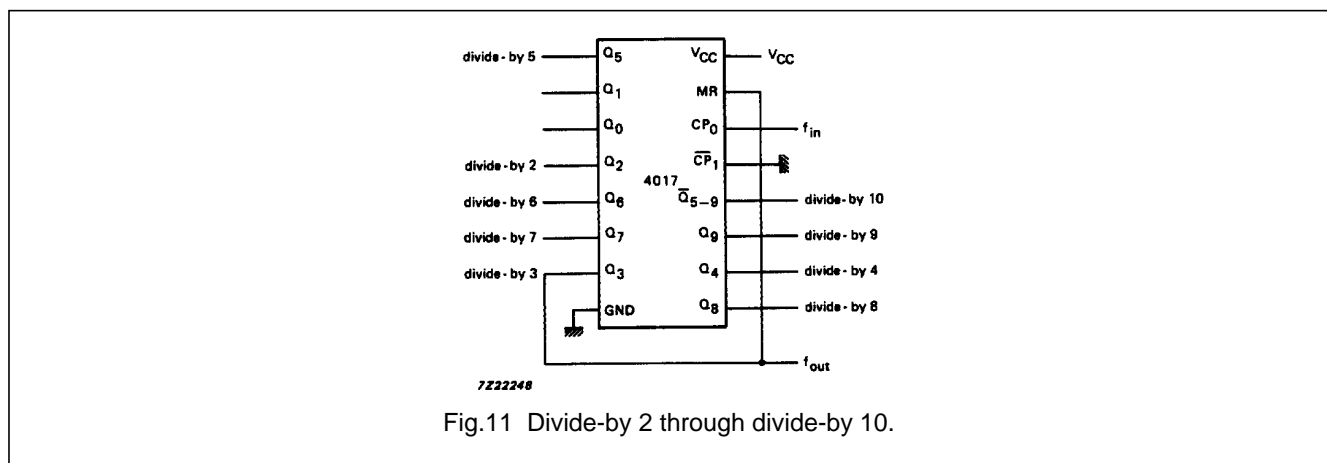

Figure 11 shows an example of a divide-by 2 through divide-by 10 circuit using one “4017”. Since “4017” has an asynchronous reset, the output pulse widths are narrow (minimum expected pulse width is 6 ns). The output pulse widths can be enlarged by inserting a RC network at the MR input.



## PACKAGE OUTLINES

See “74HC/HCT/HCU/HCMOS Logic Package Outlines”.



LittleDiode supplies new, hard to find or obsolete electronic components and semiconductors all over the world.

With over two million different components listed you are sure to find the part you need.

Feel free to visit us today at our online store:

[LittleDiode.com](http://LittleDiode.com)

Looking forward to providing you with the best possible service.