

## 54LS257A/DM54LS257B/DM74LS257B, 54LS258A/DM54LS258B/DM74LS258B TRI-STATE® Quad 2-Data Selectors/Multiplexers

### General Description

These Schottky-clamped high-performance multiplexers feature TRI-STATE outputs that can interface directly with data lines of bus-organized systems. With all but one of the common outputs disabled (at a high impedance state), the low impedance of the single enabled output will drive the bus line to a high or low logic level. To minimize the possibility that two outputs will attempt to take a common bus to opposite logic levels, the output enable circuitry is designed such that the output disable times are shorter than the output enable times.

This TRI-STATE output feature means that n-bit (paralleled) data selectors with up to 258 sources can be implemented for data buses. It also permits the use of standard TTL registers for data retention throughout the system.

### Features

- TRI-STATE versions LS157 and LS158 with same pin-outs
- Schottky-clamped for significant improvement in A-C performance
- Provides bus interface from multiple sources in high-performance systems
- Average propagation delay from data input 12 ns
- Typical power dissipation
  - LS257B 50 mW
  - LS258B 35 mW
- Alternate military/aerospace devices (54LS257A/54LS258A) are available. Contact a National Semiconductor Sales Office/Distributor for specifications.

### Connection Diagrams

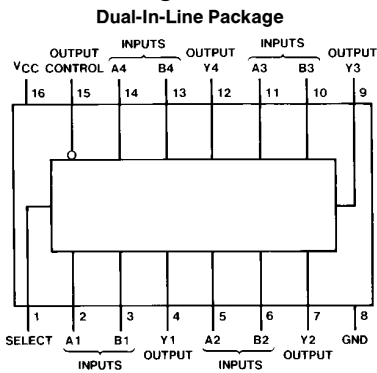

TL/F/6417-1

Order Number 54LS257ADMQB, 54LS257AFMQB,  
54LS257ALMQB, DM54LS257BJ, DM54LS257BW,  
DM74LS257BM or DM74LS257BN  
See NS Package Number E20A, J16A,  
M16A, N16E or W16A

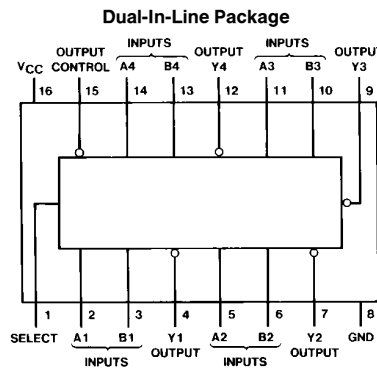

TL/F/6417-2

Order Number 54LS258ADMQB, 54LS258AFMQB,  
54LS258ALMQB, DM54LS258BJ, DM54LS258BW,  
DM74LS258BM or DM74LS258BN  
See NS Package Number E20A, J16A,  
M16A, N16E or W16A

### Function Table

Output Control	Inputs		Output Y		
	Select	A	B	LS257	LS258
H	X	X	X	Z	Z
L	L	L	X	L	H
L	L	H	X	H	L
L	H	X	L	L	H
L	H	X	H	H	L

H = High Level, L = Low Level, X = Don't Care,  
Z = High Impedance (off)

TRI-STATE® is a registered trademark of National Semiconductor Corporation.

## Absolute Maximum Ratings (Note)

If Military/Aerospace specified devices are required, please contact the National Semiconductor Sales Office/Distributors for availability and specifications.

Supply Voltage	7V
Input Voltage	7V
Operating Free Air Temperature Range	
DM54LS and 54LS	-55°C to +125°C
DM74LS	0°C to +70°C
Storage Temperature Range	-65°C to +150°C

Note: The "Absolute Maximum Ratings" are those values beyond which the safety of the device cannot be guaranteed. The device should not be operated at these limits. The parametric values defined in the "Electrical Characteristics" table are not guaranteed at the absolute maximum ratings. The "Recommended Operating Conditions" table will define the conditions for actual device operation.

## Recommended Operating Conditions

Symbol	Parameter	DM54LS257B			DM74LS257B			Units
		Min	Nom	Max	Min	Nom	Max	
V <sub>CC</sub>	Supply Voltage	4.5	5	5.5	4.75	5	5.25	V
V <sub>IH</sub>	High Level Input Voltage	2			2			V
V <sub>IL</sub>	Low Level Input Voltage			0.7			0.8	V
I <sub>OH</sub>	High Level Output Current			-1			-2.6	mA
I <sub>OL</sub>	Low Level Output Current			12			24	mA
T <sub>A</sub>	Free Air Operating Temperature	-55		125	0		70	°C

## 'LS257B Electrical Characteristics

over recommended operating free air temperature range (unless otherwise noted)

Symbol	Parameter	Conditions	Min	Typ (Note 1)	Max	Units
V <sub>I</sub>	Input Clamp Voltage	V <sub>CC</sub> = Min, I <sub>I</sub> = -18 mA			-1.5	V
V <sub>OH</sub>	High Level Output Voltage	V <sub>CC</sub> = Min, I <sub>OH</sub> = Max V <sub>IL</sub> = Max, V <sub>IH</sub> = Min	DM54 2.4	3.4		V
V <sub>OL</sub>	Low Level Output Voltage	V <sub>CC</sub> = Min, I <sub>OL</sub> = Max V <sub>IL</sub> = Max, V <sub>IH</sub> = Min	DM54 DM74	0.25 0.35	0.4 0.5	V
		I <sub>OL</sub> = 12 mA, V <sub>CC</sub> = Min	DM74	0.25	0.4	
I <sub>I</sub>	Input Current @ Max Input Voltage	V <sub>CC</sub> = Max, V <sub>I</sub> = 7V	Select		0.2	mA
			Other		0.1	
I <sub>IH</sub>	High Level Input Current	V <sub>CC</sub> = Max, V <sub>I</sub> = 2.7V	Select		40	μA
			Other		20	
I <sub>IL</sub>	Low Level Input Current	V <sub>CC</sub> = Max, V <sub>I</sub> = 0.4V	Select		-0.8	mA
			Other		-0.4	
I <sub>OZH</sub>	Off-State Output Current with High Level Output Voltage Applied	V <sub>CC</sub> = Max, V <sub>O</sub> = 2.7V V <sub>IH</sub> = Min, V <sub>IL</sub> = Max			20	μA
I <sub>OZL</sub>	Off-State Output Current with Low Level Output Voltage Applied	V <sub>CC</sub> = Max, V <sub>O</sub> = 0.4V V <sub>IH</sub> = Min, V <sub>IL</sub> = Max			-20	μA
I <sub>OS</sub>	Short Circuit Output Current	V <sub>CC</sub> = Max (Note 2)	DM54	-20	-100	mA
			DM74	-20	-100	
I <sub>CCH</sub>	Supply Current with Outputs High	V <sub>CC</sub> = Max (Note 3)		5.9	10	mA
I <sub>CCL</sub>	Supply Current with Outputs Low	V <sub>CC</sub> = Max (Note 3)		9.2	16	mA
I <sub>CCZ</sub>	Supply Current with Outputs Disabled	V <sub>CC</sub> = Max (Note 3)		12	19	mA

Note 1: All typicals are at V<sub>CC</sub> = 5V, T<sub>A</sub> = 25°C.

Note 2: Not more than one output should be shorted at a time, and the duration should not exceed one second.

Note 3: I<sub>CC</sub> is measured with all outputs open and all possible inputs grounded, while achieving the stated output conditions.

## 'LS257B Switching Characteristics

at  $V_{CC} = 5V$  and  $T_A = 25^\circ C$  (See Section 1 for Test Waveforms and Output Load)

Symbol	Parameter	From (Input) To (Output)	$R_L = 667\Omega$				Units
			$C_L = 45\text{ pF}$		$C_L = 150\text{ pF}$		
			Min	Max	Min	Max	
$t_{PLH}$	Propagation Delay Time Low to High Level Output	Data to Output		18		27	ns
$t_{PHL}$	Propagation Delay Time High to Low Level Output	Data to Output		18		27	ns
$t_{PLH}$	Propagation Delay Time Low to High Level Output	Select to Output		28		35	ns
$t_{PHL}$	Propagation Delay Time High to Low Level Output	Select to Output		35		42	ns
$t_{PZH}$	Output Enable Time to High Level Output	Output Control to Y		15		27	ns
$t_{PZL}$	Output Enable Time to Low Level Output	Output Control to Y		28		38	ns
$t_{PHZ}$	Output Disable Time from High Level Output (Note 1)	Output Control to Y		26			ns
$t_{PLZ}$	Output Disable Time from Low Level Output (Note 1)	Output Control to Y		25			ns

Note 1:  $C_L = 5\text{ pF}$ .

## Recommended Operating Conditions

Symbol	Parameter	DM54LS258B			DM74LS258B			Units
		Min	Nom	Max	Min	Nom	Max	
$V_{CC}$	Supply Voltage	4.5	5	5.5	4.75	5	5.25	V
$V_{IH}$	High Level Input Voltage	2			2			V
$V_{IL}$	Low Level Input Voltage			0.7			0.8	V
$I_{OH}$	High Level Output Current			-1			-2.6	mA
$I_{OL}$	Low Level Output Current			12			24	mA
$T_A$	Free Air Operating Temperature	-55		125	0		70	$^\circ C$

## 'LS258B Electrical Characteristics

over recommended operating free air temperature range (unless otherwise noted)

Symbol	Parameter	Conditions	Min	Typ (Note 1)	Max	Units	
$V_I$	Input Clamp Voltage	$V_{CC} = \text{Min}, I_I = -18\text{ mA}$			-1.5	V	
$V_{OH}$	High Level Output Voltage	$V_{CC} = \text{Min}, I_{OH} = \text{Max}$ $V_{IL} = \text{Max}, V_{IH} = \text{Min}$	DM54	2.4	3.4	V	
			DM74	2.4	3.1		
$V_{OL}$	Low Level Output Voltage	$V_{CC} = \text{Min}, I_{OL} = \text{Max}$ $V_{IL} = \text{Max}, V_{IH} = \text{Min}$	DM54		0.25	0.4	V
			DM74		0.35	0.5	
		DM74		0.25	0.4		
$I_I$	Input Current @ Max Input Voltage	$V_{CC} = \text{Max},$ $V_I = 7V$	Select			0.2	mA
			Other			0.1	
$I_{IH}$	High Level Input Current	$V_{CC} = \text{Max},$ $V_I = 2.7V$	Select			40	$\mu A$
			Other			20	

## 'LS258B Electrical Characteristics

over recommended operating free air temperature range (unless otherwise noted) (Continued)

Symbol	Parameter	Conditions	Min	Typ (Note 1)	Max	Units
I <sub>IL</sub>	Low Level Input Current	V <sub>CC</sub> = Max, V <sub>I</sub> = 0.4V	Select		-0.8	mA
			Other		-0.4	
I <sub>OZH</sub>	Off-State Output Current with High Level Output Voltage Applied	V <sub>CC</sub> = Max, V <sub>O</sub> = 2.7V V <sub>IH</sub> = Min, V <sub>IL</sub> = Max			20	μA
I <sub>OZL</sub>	Off-State Output Current with Low Level Output Voltage Applied	V <sub>CC</sub> = Max, V <sub>O</sub> = 0.4V V <sub>IH</sub> = Min, V <sub>IL</sub> = Max			-20	μA
I <sub>OS</sub>	Short Circuit Output Current	V <sub>CC</sub> = Max (Note 2)	DM54	-20	-100	mA
			DM74	-20	-100	
I <sub>CCH</sub>	Supply Current with Outputs High	V <sub>CC</sub> = Max (Note 3)		4.1	7	mA
I <sub>CCL</sub>	Supply Current with Outputs Low	V <sub>CC</sub> = Max (Note 3)		9	14	mA
I <sub>CCZ</sub>	Supply Current with Outputs Disabled	V <sub>CC</sub> = Max (Note 3)		12	19	mA

**Note 1:** All typicals are at V<sub>CC</sub> = 5V, T<sub>A</sub> = 25°C.

**Note 2:** Not more than one output should be shorted at a time, and the duration should not exceed one second.

**Note 3:** I<sub>CC</sub> is measured with all outputs open and all possible inputs grounded, while achieving the stated output conditions.

## 'LS258B Switching Characteristics

at V<sub>CC</sub> = 5V and T<sub>A</sub> = 25°C (See Section 1 for Test Waveforms and Output Load)

Symbol	Parameter	From (Input) To (Output)	R <sub>L</sub> = 667Ω				Units
			C <sub>L</sub> = 45 pF		C <sub>L</sub> = 150 pF		
			Min	Max	Min	Max	
t <sub>PLH</sub>	Propagation Delay Time Low to High Level Output	Data to Output		18		27	ns
t <sub>PHL</sub>	Propagation Delay Time High to Low Level Output	Data to Output		18		27	ns
t <sub>PLH</sub>	Propagation Delay Time Low to High Level Output	Select to Output		28		35	ns
t <sub>PHL</sub>	Propagation Delay Time High to Low Level Output	Select to Output		35		42	ns
t <sub>PZH</sub>	Output Enable Time to High Level Output	Output Control to Y		15		27	ns
t <sub>PZL</sub>	Output Enable Time to Low Level Output	Output Control to Y		28		38	ns
t <sub>PHZ</sub>	Output Disable Time from High Level Output (Note 4)	Output Control to Y		26			ns
t <sub>PLZ</sub>	Output Disable Time from Low Level Output (Note 4)	Output Control to Y		25			ns

**Note 4:** C<sub>L</sub> = 5 pF.

# Logic Diagrams

## LS257B

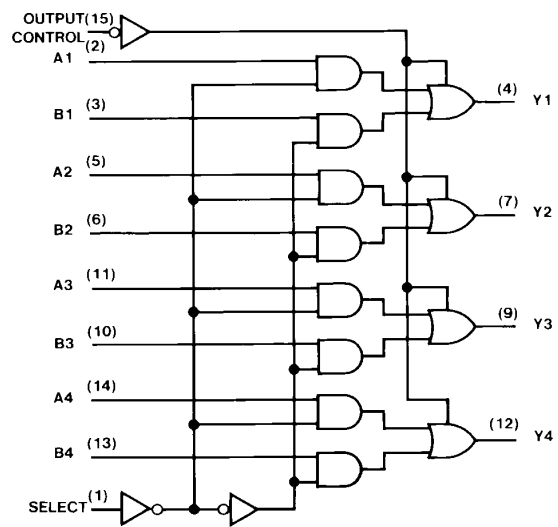

TL/F/6417-3

## LS258B

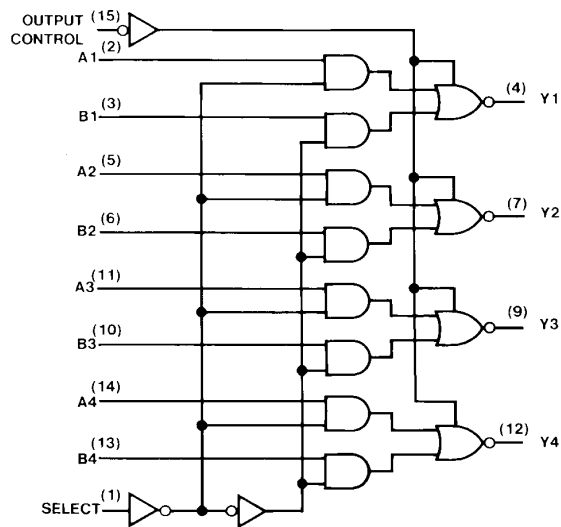

TL/F/6417-4

**Physical Dimensions** inches (millimeters)

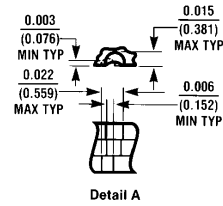
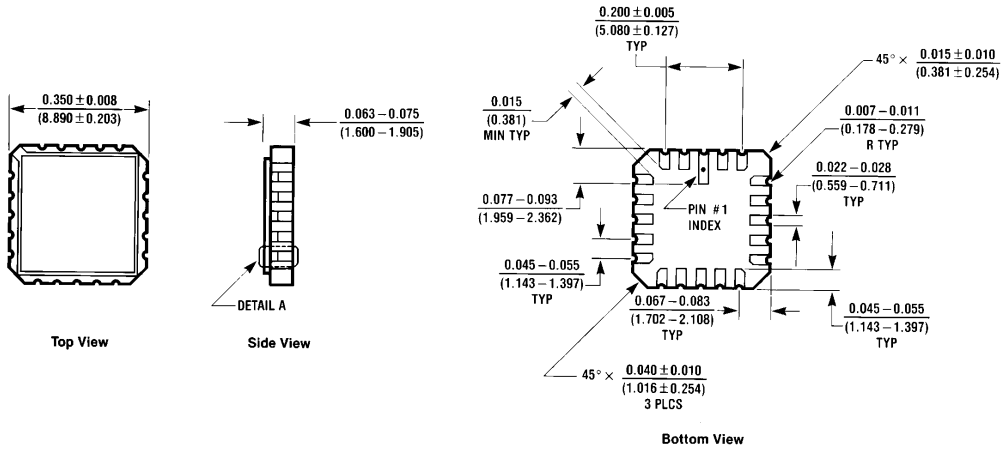

**Ceramic Leadless Chip Carrier Package (E)**  
**Order Number 54LS257ALMQB or 54LS258ALMQB**  
**NS Package Number E20A**

E20A (REV D)

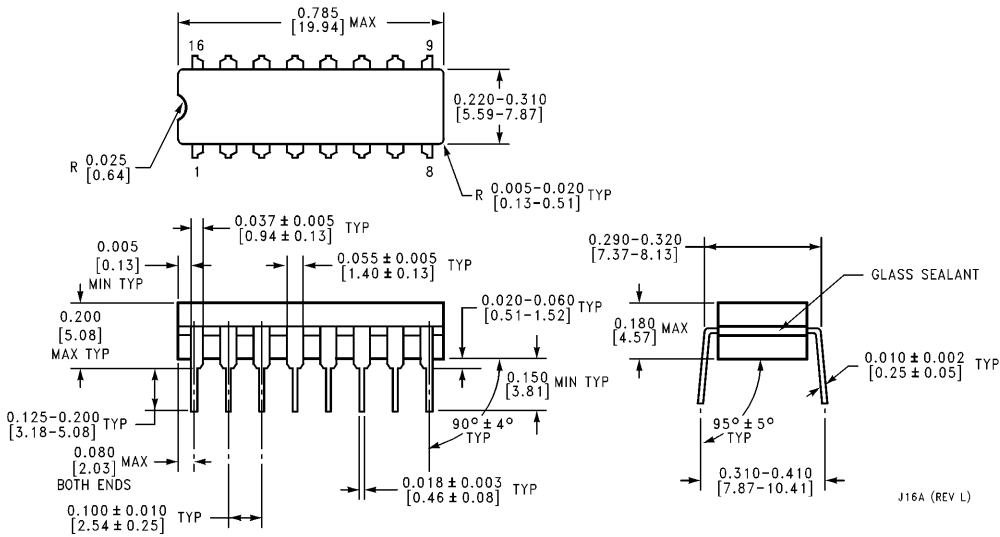

**16-Lead Ceramic Dual-In-Line Package (J)**  
**Order Number 54LS257ADMQB, 54LS258ADMQB, DM54LS257BJ or DM54LS258BJ**  
**NS Package Number J16A**

J16A (REV L)

**Physical Dimensions** inches (millimeters) (Continued)

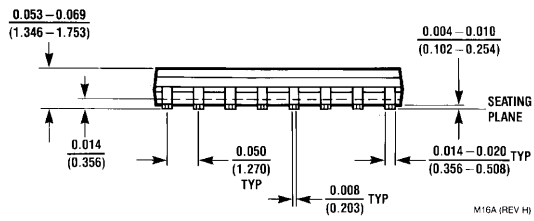
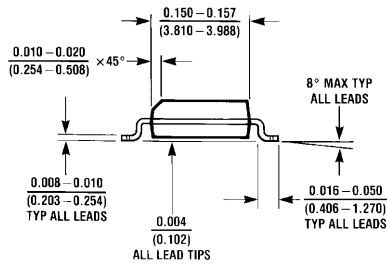
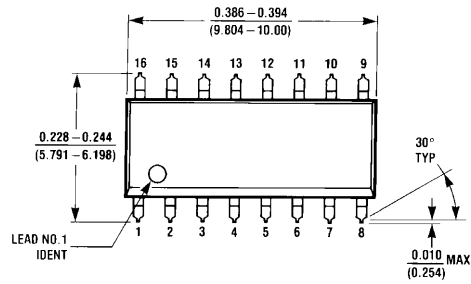

**16-Lead Small Outline Molded Package (M)**  
**Order Number DM74LS257BM or DM74LS258BM**  
**NS Package Number M16A**

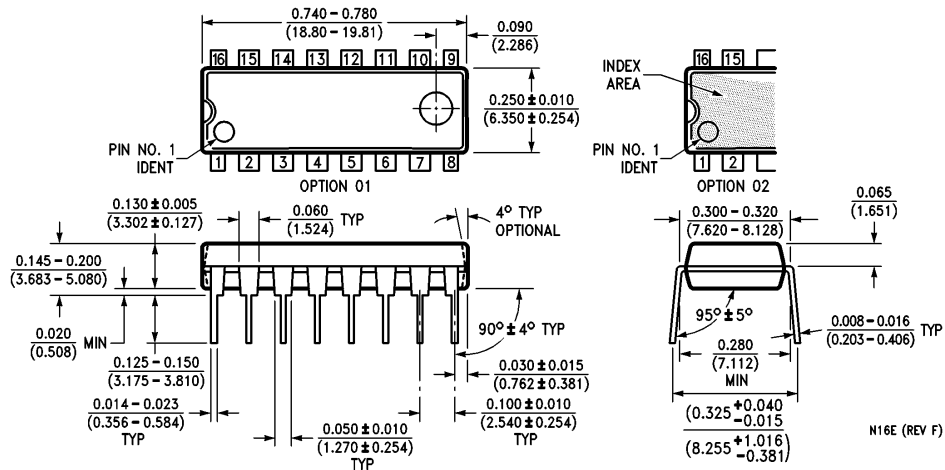

**16-Lead Molded Dual-In-Line Package (N)**  
**Order Number DM74LS257BN or DM74LS258BN**  
**NS Package Number N16E**

**Physical Dimensions** inches (millimeters) (Continued)

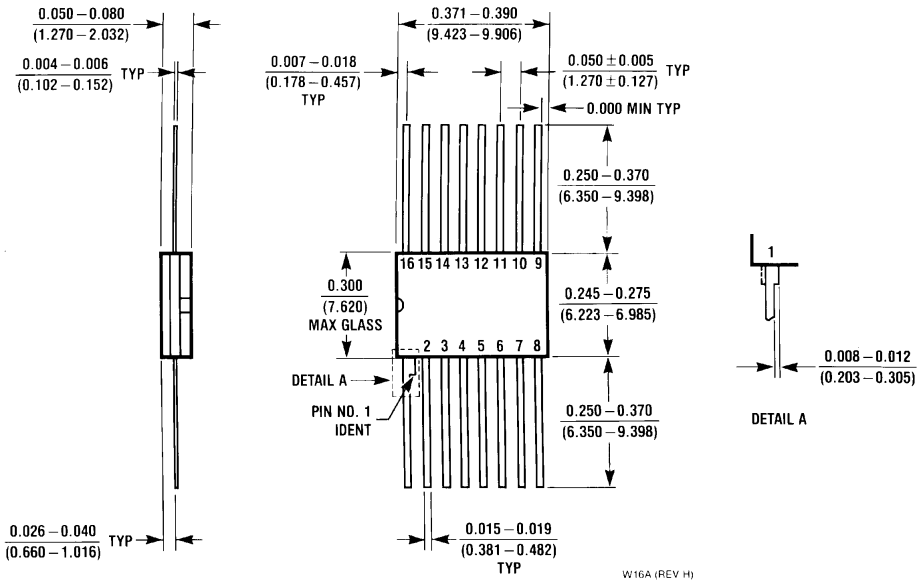

**16-Lead Ceramic Flat Package (W)**  
Order Number 54LS257AFMQB or 54LS258AFMQB  
NS Package Number W16A

W16A (REV. H)

**LIFE SUPPORT POLICY**

NATIONAL'S PRODUCTS ARE NOT AUTHORIZED FOR USE AS CRITICAL COMPONENTS IN LIFE SUPPORT DEVICES OR SYSTEMS WITHOUT THE EXPRESS WRITTEN APPROVAL OF THE PRESIDENT OF NATIONAL SEMICONDUCTOR CORPORATION. As used herein:

1. Life support devices or systems are devices or systems which, (a) are intended for surgical implant into the body, or (b) support or sustain life, and whose failure to perform, when properly used in accordance with instructions for use provided in the labeling, can be reasonably expected to result in a significant injury to the user.
2. A critical component is any component of a life support device or system whose failure to perform can be reasonably expected to cause the failure of the life support device or system, or to affect its safety or effectiveness.



**National Semiconductor Corporation**  
1111 West Bardin Road  
Arlington, TX 76017  
Tel: 1(800) 272-9959  
Fax: 1(800) 737-7018

**National Semiconductor Europe**  
Fax: (+49) 0-180-530 85 86  
Email: onjwge@tevm2.nsc.com  
Deutsch Tel: (+49) 0-180-530 85 85  
English Tel: (+49) 0-180-532 78 32  
Français Tel: (+49) 0-180-532 93 58  
Italiano Tel: (+49) 0-180-534 16 80

**National Semiconductor Hong Kong Ltd.**  
19th Floor, Straight Block,  
Ocean Centre, 5 Canton Rd.  
Tsimshatsui, Kowloon  
Hong Kong  
Tel: (852) 2737-1600  
Fax: (852) 2736-9960

**National Semiconductor Japan Ltd.**  
Tel: 81-043-299-2309  
Fax: 81-043-299-2408

National does not assume any responsibility for use of any circuitry described, no circuit patent licenses are implied and National reserves the right at any time without notice to change said circuitry and specifications.

# National Semiconductor was acquired by Texas Instruments.

[http://www.ti.com/corp/docs/investor\\_relations/pr\\_09\\_23\\_2011\\_national\\_semiconductor.html](http://www.ti.com/corp/docs/investor_relations/pr_09_23_2011_national_semiconductor.html)

This file is the datasheet for the following electronic components:

DM54LS258B - <http://www.ti.com/product/dm54ls258b?HQS=TI-null-null-dscatalog-df-pf-null-ww>

DM74LS258B - <http://www.ti.com/product/dm74ls258b?HQS=TI-null-null-dscatalog-df-pf-null-ww>

54LS258 - <http://www.ti.com/product/54ls258?HQS=TI-null-null-dscatalog-df-pf-null-ww>

DM74LS257B - <http://www.ti.com/product/dm74ls257b?HQS=TI-null-null-dscatalog-df-pf-null-ww>

54LS257 - <http://www.ti.com/product/54ls257?HQS=TI-null-null-dscatalog-df-pf-null-ww>

DM54LS257B - <http://www.ti.com/product/dm54ls257b?HQS=TI-null-null-dscatalog-df-pf-null-ww>



LittleDiode supplies new, hard to find or obsolete electronic components and semiconductors all over the world.

With over two million different components listed you are sure to find the part you need.

Feel free to visit us today at our online store:

[LittleDiode.com](http://LittleDiode.com)

Looking forward to providing you with the best possible service.