

54LS193/DM54LS193/DM74LS193 Synchronous 4-Bit Up/Down Binary Counters with Dual Clock

General Description

This circuit is a synchronous up/down 4-bit binary counter. Synchronous operation is provided by having all flip-flops clocked simultaneously, so that the outputs change together when so instructed by the steering logic. This mode of operation eliminates the output counting spikes normally associated with asynchronous (ripple-clock) counters.

The outputs of the four master-slave flip-flops are triggered by a low-to-high level transition of either count (clock) input. The direction of counting is determined by which count input is pulsed while the other count input is held high.

The counter is fully programmable; that is, each output may be preset to either level by entering the desired data at the inputs while the load input is low. The output will change independently of the count pulses. This feature allows the counters to be used as modulo-N dividers by simply modifying the count length with the preset inputs.

A clear input has been provided which, when taken to a high level, forces all outputs to the low level; independent of the count and load inputs. The clear, count, and load inputs are buffered to lower the drive requirements of clock drivers, etc., required for long words.

These counters were designed to be cascaded without the need for external circuitry. Both borrow and carry outputs are available to cascade both the up and down counting functions. The borrow output produces a pulse equal in width to the count down input when the counter underflows.

Similarly, the carry output produces a pulse equal in width to the count down input when an overflow condition exists. The counters can then be easily cascaded by feeding the borrow and carry outputs to the count down and count up inputs respectively of the succeeding counter.

Features

- Fully independent clear input
- Synchronous operation
- Cascading circuitry provided internally
- Individual preset each flip-flop
- Alternate Military/Aerospace device (54LS193) is available. Contact a National Semiconductor Sales Office/Distributor for specifications.

Connection Diagram

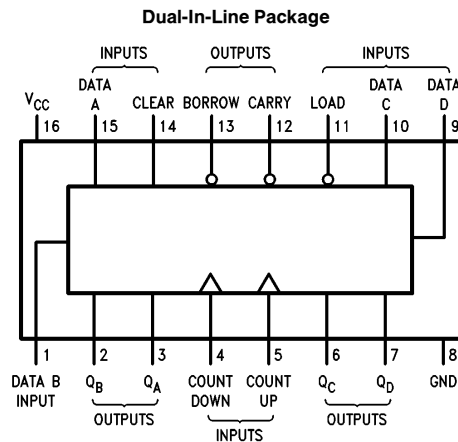

Order Number 54LS193DMQB, 54LS193FMQB, 54LS193LMQB,
DM54LS193J, DM54LS193W, DM74LS193M or DM74LS193N
See NS Package Number E20A, J16A, M16A, N16E or W16A

54LS193/DM54LS193/DM74LS193 Synchronous 4-Bit Up/Down Counters with Dual Clock

Absolute Maximum Ratings (Note)

If Military/Aerospace specified devices are required, please contact the National Semiconductor Sales Office/Distributors for availability and specifications.

Supply Voltage	7V
Input Voltage	7V
Operating Free Air Temperature Range	
DM54LS and 54LS	−55°C to +125°C
DM74LS	0°C to +70°C
Storage Temperature Range	−65°C to +150°C

Note: The "Absolute Maximum Ratings" are those values beyond which the safety of the device cannot be guaranteed. The device should not be operated at these limits. The parametric values defined in the "Electrical Characteristics" table are not guaranteed at the absolute maximum ratings. The "Recommended Operating Conditions" table will define the conditions for actual device operation.

Recommended Operating Conditions

Symbol	Parameter	DM54LS193			DM74LS193			Units
		Min	Nom	Max	Min	Nom	Max	
V _{CC}	Supply Voltage	4.5	5	5.5	4.75	5	5.25	V
V _{IH}	High Level Input Voltage	2			2			V
V _{IL}	Low Level Input Voltage			0.7			0.8	V
I _{OH}	High Level Output Current			−0.4			−0.4	mA
I _{OL}	Low Level Output Current			4			8	mA
f _{CLK}	Clock Frequency (Note 1)	0		25	0		25	MHz
	Clock Frequency (Note 2)	0		20	0		20	MHz
t _W	Pulse Width of Any Input (Note 6)	20			20			ns
t _{SU}	Data Setup Time (Note 6)	20			20			ns
t _H	Data Hold Time (Note 6)	0			0			ns
t _{REL}	Release Time (Note 6)	40			40			ns
T _A	Free Air Operating Temperature	−55		125	0		70	°C

Electrical Characteristics over recommended operating free air temperature range (unless otherwise noted)

Symbol	Parameter	Conditions	Min	Typ (Note 3)	Max	Units	
V _I	Input Clamp Voltage	V _{CC} = Min, I _I = −18 mA			−1.5	V	
V _{OH}	High Level Output Voltage	V _{CC} = Min, I _{OH} = Max V _{IL} = Max, V _{IH} = Min	DM54	2.5	3.4	V	
			DM74	2.7	3.4		
V _{OL}	Low Level Output Voltage	V _{CC} = Min, I _{OL} = Max V _{IL} = Max, V _{IH} = Min	DM54		0.25	0.4	V
			DM74		0.35	0.5	
			DM74	I _{OL} = 4 mA, V _{CC} = Min		0.25	
I _I	Input Current @ Max Input Voltage	V _{CC} = Max, V _I = 7V			0.1	mA	
I _{IH}	High Level Input Current	V _{CC} = Max, V _I = 2.7V			20	μA	
I _{IL}	Low Level Input Current	V _{CC} = Max, V _I = 0.4V			−0.4	mA	
I _{OS}	Short Circuit Output Current	V _{CC} = Max (Note 4)	DM54	−20		−100	mA
			DM74	−20		−100	
I _{CC}	Supply Current	V _{CC} = Max (Note 5)		19	34	mA	

Note 1: C_L = 15 pF, R_L = 2 kΩ, I_A = 25°C and V_{CC} = 5V.

Note 2: C_L = 50 pF, R_L = 2 kΩ, I_A = 25°C and V_{CC} = 5V.

Note 3: All typicals are at V_{CC} = 5V, T_A = 25°C.

Note 4: Not more than one output should be shorted at a time, and the duration should not exceed one second.

Note 5: I_{CC} is measured with all outputs open, CLEAR and LOAD inputs grounded, and all other inputs at 4.5V.

Note 6: T_A = 25°C and V_{CC} = 5V.

Switching Characteristics at $V_{CC} = 5V$ and $T_A = 25^\circ C$ (See Section 1 for Test Waveforms and Output Load)

Symbol	Parameter	From (Input) To (Output)	$R_L = 2\text{ k}\Omega$				Units
			$C_L = 15\text{ pF}$		$C_L = 50\text{ pF}$		
			Min	Max	Min	Max	
f_{MAX}	Maximum Clock Frequency		25		20		MHz
t_{PLH}	Propagation Delay Time Low to High Level Output	Count Up to Carry		26		30	ns
t_{PHL}	Propagation Delay Time High to Low Level Output	Count Up to Carry		24		36	ns
t_{PLH}	Propagation Delay Time Low to High Level Output	Count Down to Borrow		24		29	ns
t_{PHL}	Propagation Delay Time High to Low Level Output	Count Down to Borrow		24		32	ns
t_{PLH}	Propagation Delay Time Low to High Level Output	Either Count to Any Q		38		45	ns
t_{PHL}	Propagation Delay Time High to Low Level Output	Either Count to Any Q		47		54	ns
t_{PLH}	Propagation Delay Time Low to High Level Output	Load to Any Q		40		41	ns
t_{PHL}	Propagation Delay Time High to Low Level Output	Load to Any Q		40		47	ns
t_{PHL}	Propagation Delay Time High to Low Level Output	Clear to Any Q		35		44	ns

Logic Diagram

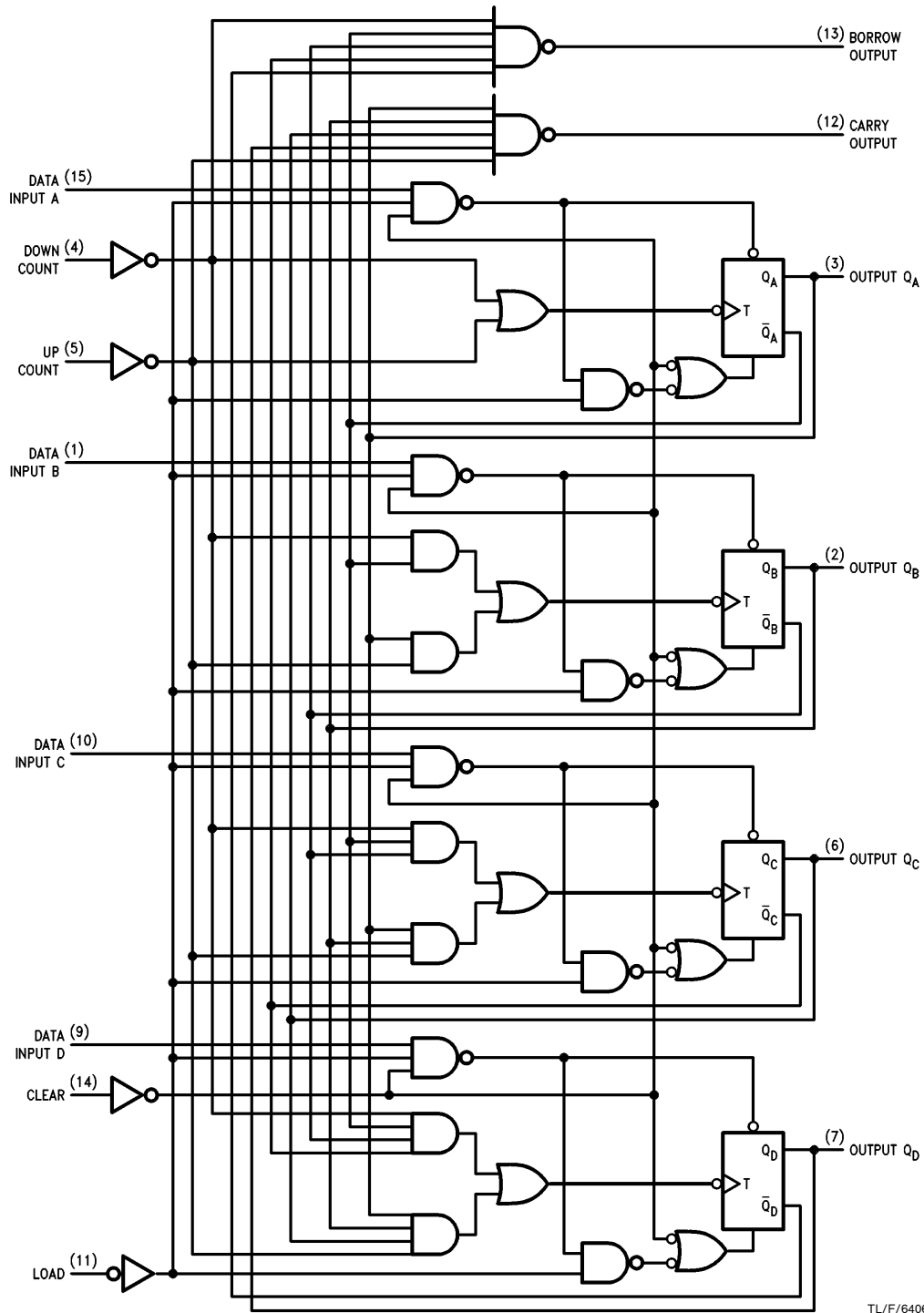

TL/F/6406-2

Timing Diagrams

Typical Clear, Load, and Count Sequences

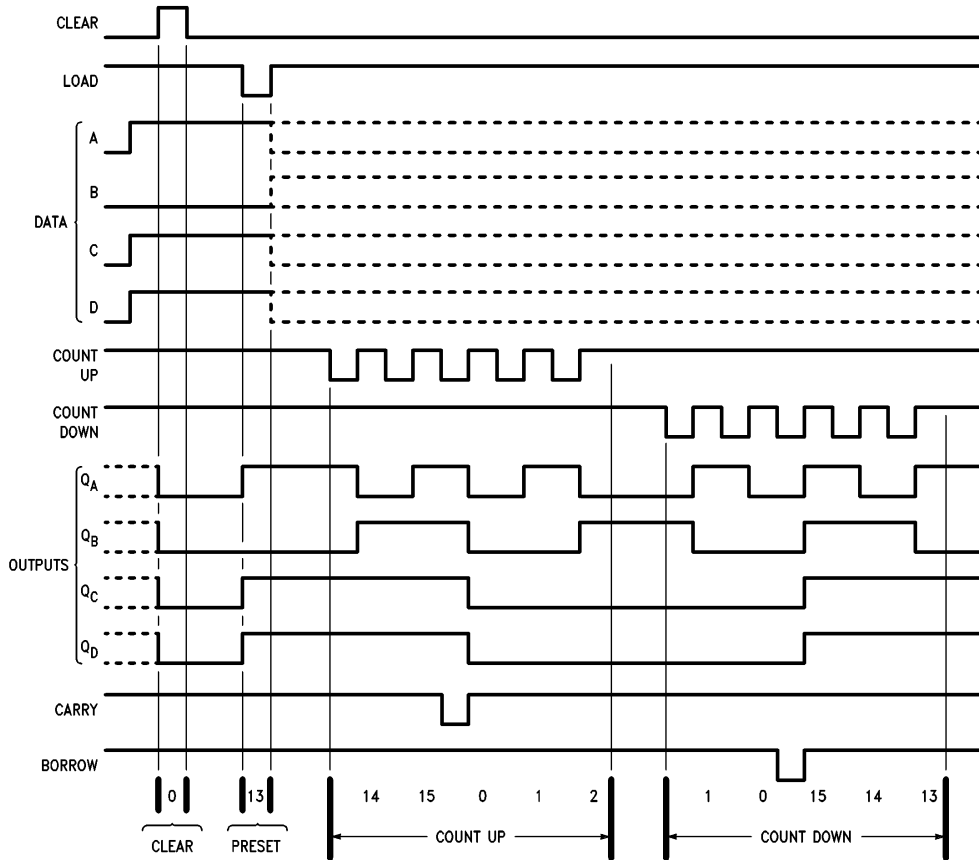

TL/F/6406-3

Note A: Clear overrides load, data, and count inputs.

Note B: When counting up, count-down input must be high; when counting down, count-up input must be high.

Physical Dimensions inches (millimeters)

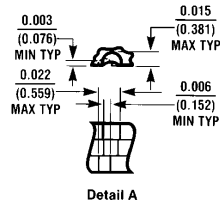
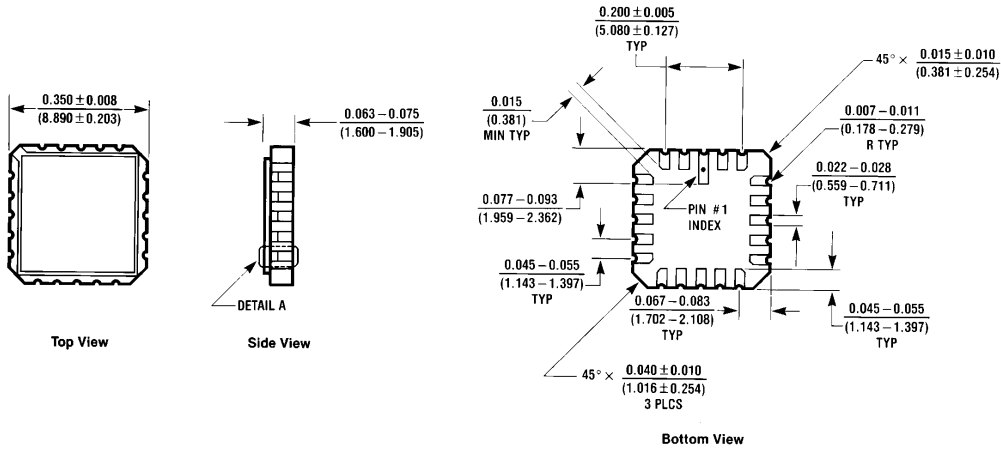

Ceramic Leadless Chip Carrier Package (E)
Order Number 54LS193LMQB
NS Package Number E20A

E20A (REV D)

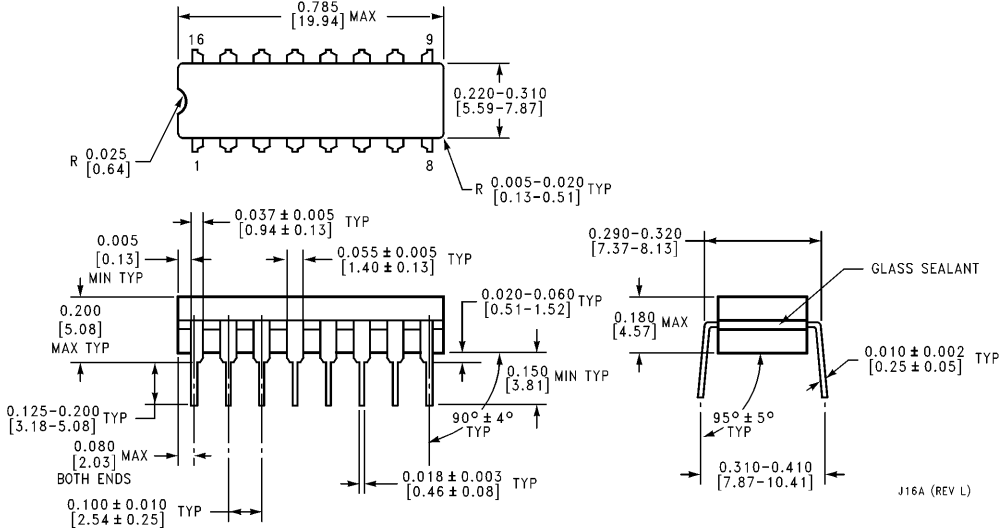

16-Lead Ceramic Dual-In-Line Package (J)
Order Number 54LS193DMQB or DM54LS193J
NS Package Number J16A

J16A (REV L)

Physical Dimensions inches (millimeters) (Continued)

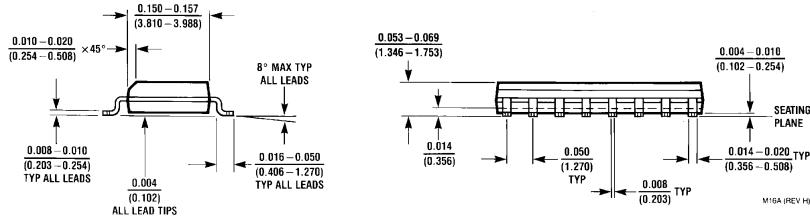
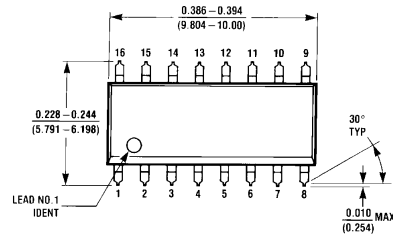

16-Lead Small Outline Molded Package (M)
Order Number DM74LS193M
NS Package Number M16A

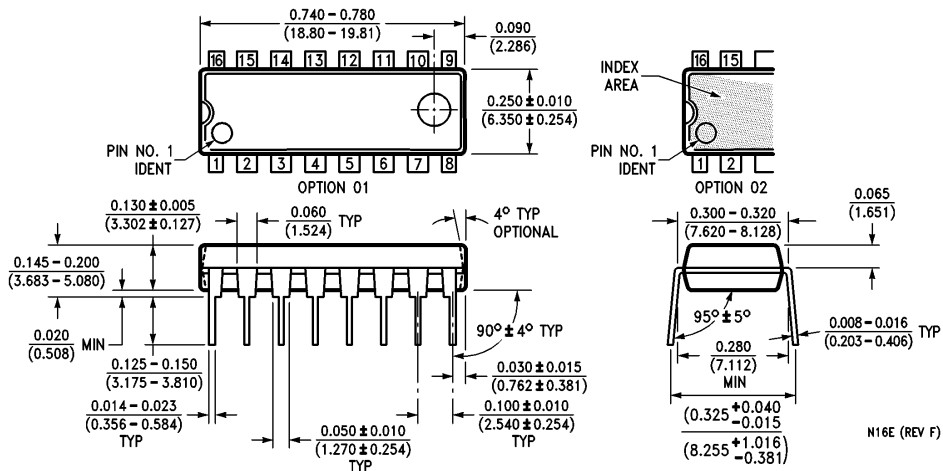

16-Lead Molded Dual-In-Line Package (N)
Order Number DM74LS193N
NS Package Number N16E

Physical Dimensions inches (millimeters) (Continued)

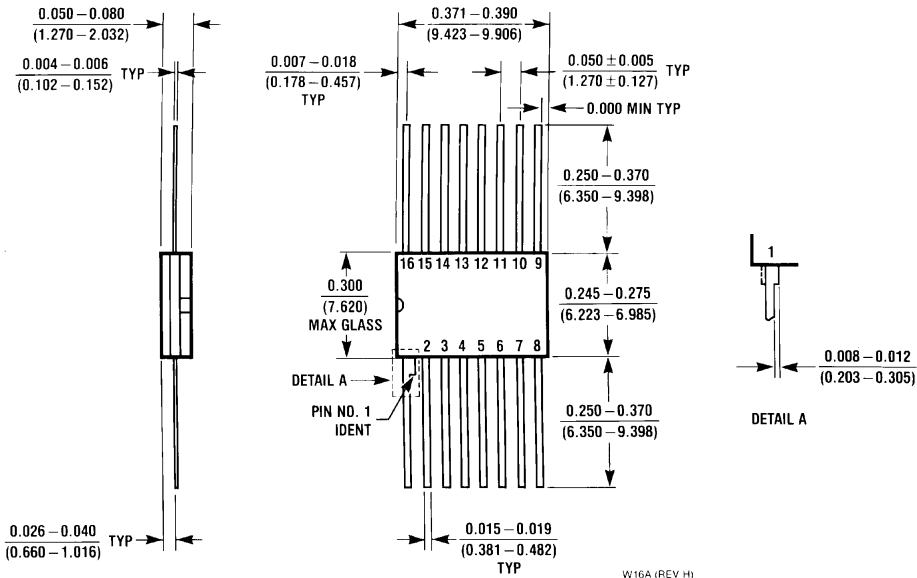

16-Lead Ceramic Flat Package (W)
Order Number 54LS193FMQB or DM54LS193W
NS Package Number W16A

W16A (REV. H)

LIFE SUPPORT POLICY

NATIONAL'S PRODUCTS ARE NOT AUTHORIZED FOR USE AS CRITICAL COMPONENTS IN LIFE SUPPORT DEVICES OR SYSTEMS WITHOUT THE EXPRESS WRITTEN APPROVAL OF THE PRESIDENT OF NATIONAL SEMICONDUCTOR CORPORATION. As used herein:

1. Life support devices or systems are devices or systems which, (a) are intended for surgical implant into the body, or (b) support or sustain life, and whose failure to perform, when properly used in accordance with instructions for use provided in the labeling, can be reasonably expected to result in a significant injury to the user.
2. A critical component is any component of a life support device or system whose failure to perform can be reasonably expected to cause the failure of the life support device or system, or to affect its safety or effectiveness.



National Semiconductor Corporation
 1111 West Bardin Road
 Arlington, TX 76017
 Tel: 1(800) 272-9959
 Fax: 1(800) 737-7018

National Semiconductor Europe
 Fax: (+49) 0-180-530 85 86
 Email: onjwge@tevm2.nsc.com
 Deutsch Tel: (+49) 0-180-530 85 85
 English Tel: (+49) 0-180-532 78 32
 Français Tel: (+49) 0-180-532 93 58
 Italiano Tel: (+49) 0-180-534 16 80

National Semiconductor Hong Kong Ltd.
 13th Floor, Straight Block,
 Ocean Centre, 5 Canton Rd.
 Tsimshatsui, Kowloon
 Hong Kong
 Tel: (852) 2737-1600
 Fax: (852) 2736-9960

National Semiconductor Japan Ltd.
 Tel: 81-043-299-2309
 Fax: 81-043-299-2408

National does not assume any responsibility for use of any circuitry described, no circuit patent licenses are implied and National reserves the right at any time without notice to change said circuitry and specifications.

National Semiconductor was acquired by Texas Instruments.

http://www.ti.com/corp/docs/investor_relations/pr_09_23_2011_national_semiconductor.html

This file is the datasheet for the following electronic components:

DM54LS193 - <http://www.ti.com/product/dm54ls193?HQS=TI-null-null-dscatalog-df-pf-null-ww>

DM74LS193 - <http://www.ti.com/product/dm74ls193?HQS=TI-null-null-dscatalog-df-pf-null-ww>

54LS193 - <http://www.ti.com/product/54ls193?HQS=TI-null-null-dscatalog-df-pf-null-ww>



LittleDiode supplies new, hard to find or obsolete electronic components and semiconductors all over the world.

With over two million different components listed you are sure to find the part you need.

Feel free to visit us today at our online store:

LittleDiode.com

Looking forward to providing you with the best possible service.