

DATA SHEET

For a complete data sheet, please also download:

- The IC06 74HC/HCT/HCU/HCMOS Logic Family Specifications
- The IC06 74HC/HCT/HCU/HCMOS Logic Package Information
- The IC06 74HC/HCT/HCU/HCMOS Logic Package Outlines

74HC/HCT356

8-input multiplexer/register; 3-state

Product specification
File under Integrated Circuits, IC06

December 1990

8-input multiplexer/register; 3-state

74HC/HCT356

FEATURES

- Non-transparent data latches
- Transparent address latch
- Easily expanding
- Complementary outputs
- Output capability: bus driver
- I_{CC} category: MSI

GENERAL DESCRIPTION

The 74HC/HCT356 are high-speed Si-gate CMOS devices and are pin compatible with low power Schottky TTL

(LSTTL). They are specified in compliance with JEDEC standard no. 7A.

The 74HC/HCT356 data selectors/multiplexers contain full on-chip binary decoding, to select one-of-eight data sources. The data select address is stored in transparent latches that are enabled by a LOW on the latch enable input \overline{LE} .

Data on the 8 input lines (D₀ to D₇) is clocked into a edge-triggered data register by a LOW-to-HIGH transition of the clock (CP).

When the output enable input $\overline{OE}_1 = \text{HIGH}$, $\overline{OE}_2 = \text{HIGH}$ or $\overline{OE}_3 = \text{LOW}$, the outputs go to the high impedance OFF-state.

Operation of these output enable inputs does not affect the state of the latches and register.

QUICK REFERENCE DATA

GND = 0 V; T_{amb} = 25 °C; t_r = t_f = 6 ns

SYMBOL	PARAMETER	CONDITIONS	TYPICAL		UNIT
			HC	HCT	
t _{PHL} / t _{PLH}	propagation delay S _n , \overline{LE} to Y, \overline{Y} CP to Y, \overline{Y}	C _L = 15 pF; V _{CC} = 5 V	24	25	ns
			20	22	ns
C _I	input capacitance		3.5	3.5	pF
C _{PD}	power dissipation capacitance per package	notes 1 and 2	123	125	pF

Notes

1. C_{PD} is used to determine the dynamic power dissipation (P_D in μW):

$$P_D = C_{PD} \times V_{CC}^2 \times f_i + \sum (C_L \times V_{CC}^2 \times f_o) \text{ where:}$$

f_i = input frequency in MHz

f_o = output frequency in MHz

$\sum (C_L \times V_{CC}^2 \times f_o)$ = sum of outputs

C_L = output load capacitance in pF

V_{CC} = supply voltage in V

2. For HC the condition is V_I = GND to V_{CC}
For HCT the condition is V_I = GND to V_{CC} - 1.5 V

ORDERING INFORMATION

See "74HC/HCT/HCU/HCMOS Logic Package Information".

8-input multiplexer/register; 3-state

74HC/HCT356

PIN DESCRIPTION

PIN NO.	SYMBOL	NAME AND FUNCTION
8, 7, 6, 5, 4, 3, 2, 1	D ₀ to D ₇	data inputs
9	CP	clock input data (LOW-to-HIGH, edge-triggered)
10	GND	ground (0 V)
11	\overline{LE}	address latch enable input (active LOW)
14, 13, 12	S ₀ , S ₁ , S ₂	select inputs
15, 16	$\overline{OE_1}$, $\overline{OE_2}$	output enable inputs (active LOW)
17	OE ₃	output enable input (active HIGH)
18	\overline{Y}	3-state multiplexer output (active LOW)
19	Y	3-state multiplexer output (active HIGH)
20	V _{CC}	positive supply voltage

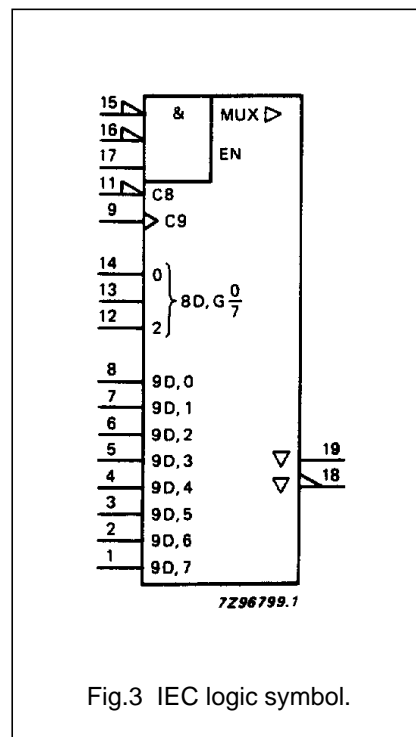
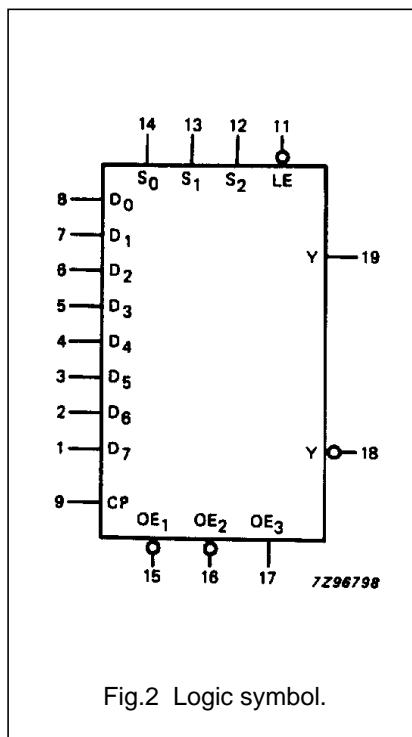
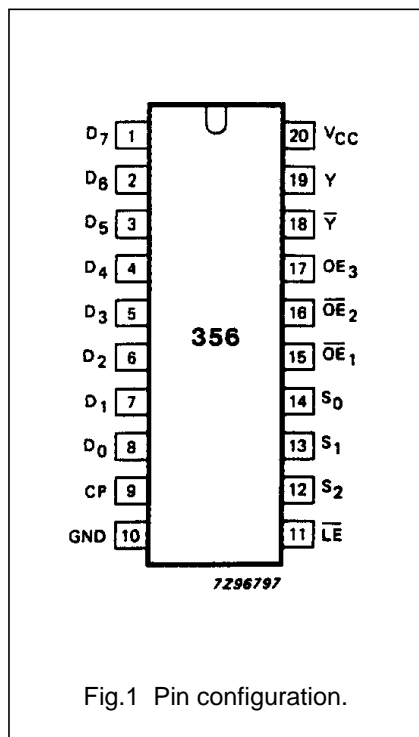

8-input multiplexer/register; 3-state

74HC/HCT356

FUNCTION TABLE

INPUTS							OUTPUTS		DESCRIPTION
ADDRESS ⁽¹⁾			CP	OUTPUT ENABLE			Y	\bar{Y}	
S ₂	S ₁	S ₀		\overline{OE}_1	\overline{OE}_2	OE ₃			
X	X	X	X	H	X	X	Z	Z	outputs in high impedance OFF-state
X	X	X	X	X	H	X	Z	Z	
X	X	X	X	X	X	L	Z	Z	
L	L	L	↑	L	L	H	D _{0n}	\overline{D}_{0n}	data is clocked into latch
L	L	H	↑	L	L	H	D _{1n}	\overline{D}_{1n}	
L	H	L	↑	L	L	H	D _{2n}	\overline{D}_{2n}	
L	H	H	↑	L	L	H	D _{3n}	\overline{D}_{3n}	
H	L	L	↑	L	L	H	D _{4n}	\overline{D}_{4n}	
H	L	H	↑	L	L	H	D _{5n}	\overline{D}_{5n}	
H	H	L	↑	L	L	H	D _{6n}	\overline{D}_{6n}	
H	H	H	↑	L	L	H	D _{7n}	\overline{D}_{7n}	
L	L	L	(2)	L	L	H	D _{0p}	\overline{D}_{0p}	outputs do not change states
L	L	H	(2)	L	L	H	D _{1p}	\overline{D}_{1p}	
L	H	L	(2)	L	L	H	D _{2p}	\overline{D}_{2p}	
L	H	H	(2)	L	L	H	D _{3p}	\overline{D}_{3p}	
H	L	L	(2)	L	L	H	D _{4p}	\overline{D}_{4p}	
H	L	H	(2)	L	L	H	D _{5p}	\overline{D}_{5p}	
H	H	L	(2)	L	L	H	D _{6p}	\overline{D}_{6p}	
H	H	H	(2)	L	L	H	D _{7p}	\overline{D}_{7p}	

Notes

- This column shows the input address set-up with $\overline{LE} = \text{LOW}$ (address latch is transparent).
- CP is HIGH, LOW or ↓.
- D_{0n} to D_{7n} = data present at inputs D₀ to D₇ when the data latch clock made the transition from LOW-to-HIGH
D_{0p} to D_{7p} = data previously latched into the data latch by the LOW-to-HIGH transition of the data latch clock
H = HIGH voltage level
L = LOW voltage level
X = don't care
↑ = LOW-to-HIGH CP transition
↓ = HIGH-to-LOW CP transition
Z = high impedance OFF-state

8-input multiplexer/register; 3-state

74HC/HCT356

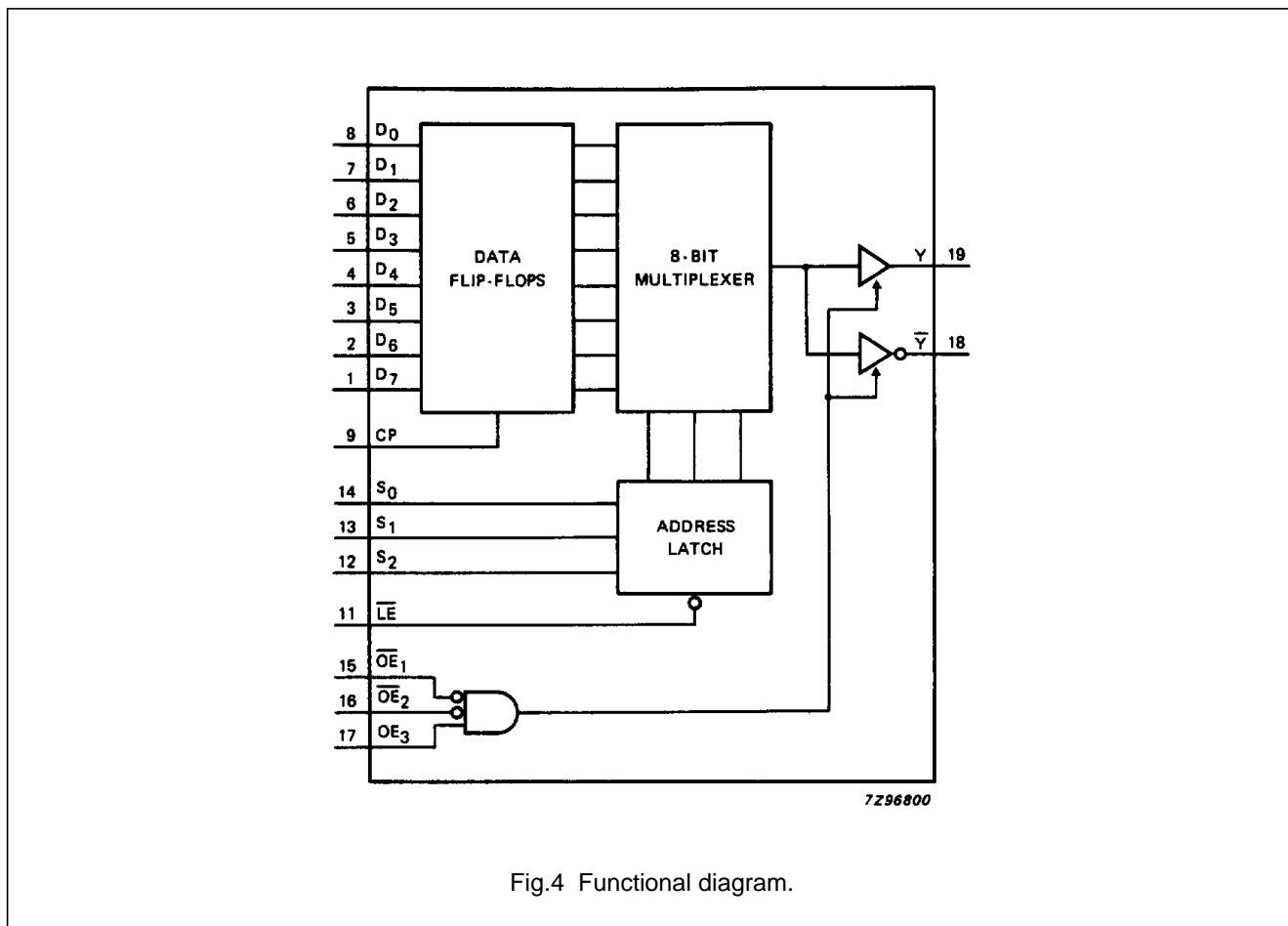

Fig.4 Functional diagram.

8-input multiplexer/register; 3-state

74HC/HCT356

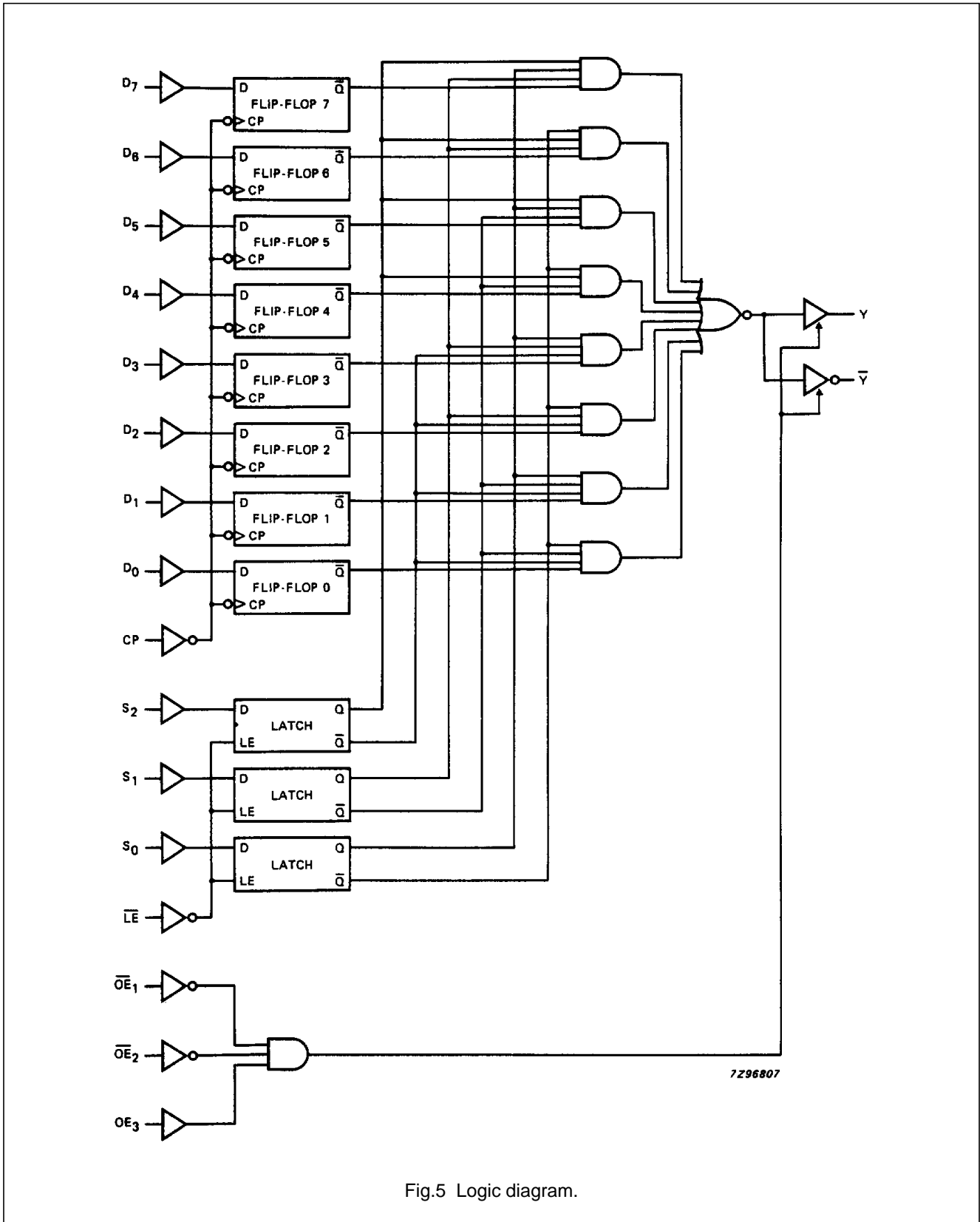

Fig.5 Logic diagram.

8-input multiplexer/register; 3-state

74HC/HCT356

DC CHARACTERISTICS FOR 74HC

For the DC characteristics see *"74HC/HCT/HCU/HCMOS Logic Family Specifications"*.

Output capability: bus driver

I_{CC} category: MSI

AC CHARACTERISTICS FOR 74HC

GND = 0 V; t_r = t_f = 6 ns; C_L = 50 pF

SYMBOL	PARAMETER	T _{amb} (°C)						UNIT	TEST CONDITIONS		
		74HC							V _{CC} (V)	WAVEFORMS	
		+25			-40 to +85		-40 to +125				
		min.	typ.	max.	min.	max.	min.				max.
t _{PHL} / t _{PLH}	propagation delay CP to Y, \bar{Y}		66 24 19	240 48 41		300 60 51		360 72 61	ns	2.0 4.5 6.0	Fig.6
t _{PHL} / t _{PLH}	propagation delay S _n to Y, \bar{Y}		77 28 22	260 52 44		325 65 55		390 78 66	ns	2.0 4.5 6.0	Fig.7
t _{PHL} / t _{PLH}	propagation delay \overline{LE} to Y, \bar{Y}		77 28 22	270 54 46		340 68 58		405 81 69	ns	2.0 4.5 6.0	Fig.8
t _{PZH} / t _{PZL}	3-state output enable time \overline{OE}_n to Y, \bar{Y}		41 15 12	125 25 21		155 31 26		190 38 32	ns	2.0 4.5 6.0	Fig.11
t _{PZH} / t _{PZL}	3-state output enable time OE ₃ to Y, \bar{Y}		47 17 14	150 30 26		190 38 33		225 45 38	ns	2.0 4.5 6.0	Fig.11
t _{PHZ} / t _{PLZ}	3-state output disable time \overline{OE}_n to Y, \bar{Y}		50 18 14	155 31 26		195 39 33		235 47 40	ns	2.0 4.5 6.0	Fig.11
t _{PHZ} / t _{PLZ}	3-state output disable time OE ₃ to Y, \bar{Y}		58 21 17	155 31 26		195 39 33		235 47 40	ns	2.0 4.5 6.0	Fig.11
t _{THL} / t _{TLH}	output transition time		14 5 4	60 12 10		75 15 13		90 18 15	ns	2.0 4.5 6.0	Figs 6, 7 and 8
t _w	clock pulse width CP HIGH or LOW	80 16 14	17 6 5		100 20 17		120 24 20		ns	2.0 4.5 6.0	Fig.6
t _w	latch enable pulse width \overline{LE} LOW	80 16 14	17 6 5		100 20 17		120 24 20		ns	2.0 4.5 6.0	Fig.8
t _{su}	set-up time D _n to CP	50 10 9	11 4 3		65 13 11		75 15 13		ns	2.0 4.5 6.0	Fig.10

8-input multiplexer/register; 3-state

74HC/HCT356

SYMBOL	PARAMETER	T _{amb} (°C)						UNIT	TEST CONDITIONS		
		74HC							V _{CC} (V)	WAVEFORMS	
		+25			-40 to +85		-40 to +125				
		min.	typ.	max.	min.	max.	min.				max.
t _{su}	set-up time S _n to \overline{LE}	50	14		65		75	ns	2.0 4.5 6.0	Fig.9	
		10	5		13		15				
		9	4		11		13				
t _h	hold time D _n to CP	5	-6		5		5	ns	2.0 4.5 6.0	Fig.10	
		5	-2		5		5				
		5	-2		5		5				
t _h	hold time S _n to \overline{LE}	5	-8		5		5	ns	2.0 4.5 6.0	Fig.9	
		5	-3		5		5				
		5	-2		5		5				

8-input multiplexer/register; 3-state**74HC/HCT356**

DC CHARACTERISTICS FOR 74HCT

For the DC characteristics see *"74HC/HCT/HCU/HCMOS Logic Family Specifications"*.

Output capability: bus driver

I_{CC} category: MSI

Note to HCT types

The value of additional quiescent supply current (ΔI_{CC}) for a unit load of 1 is given in the family specifications. To determine ΔI_{CC} per input, multiply this value by the unit load coefficient shown in the table below.

INPUT	UNIT LOAD COEFFICIENT
D _n , S _n	0.2
OE ₃	0.25
\overline{LE}	0.5
\overline{OE}_n , CP	1.0

8-input multiplexer/register; 3-state

74HC/HCT356

AC CHARACTERISTICS FOR 74HCT

GND = 0 V; $t_r = t_f = 6$ ns; $C_L = 50$ pF

SYMBOL	PARAMETER	T _{amb} (°C)						UNIT	TEST CONDITIONS		
		74HCT							V _{CC} (V)	WAVEFORMS	
		+25			-40 to +85		-40 to +125				
		min.	typ.	max.	min.	max.	min.				max.
t _{PHL} / t _{PLH}	propagation delay CP to Y, \bar{Y}		26	51		64		77	ns	4.5	Fig.6
t _{PHL} / t _{PLH}	propagation delay S _n to Y, \bar{Y}		28	59		74		89	ns	4.5	Fig.7
t _{PHL} / t _{PLH}	propagation delay \bar{LE} to Y, \bar{Y}		29	63		79		95	ns	4.5	Fig.8
t _{PZH} / t _{PZL}	3-state output enable time \bar{OE}_n to Y, \bar{Y}		17	34		43		51	ns	4.5	Fig.11
t _{PZH} / t _{PZL}	3-state output enable time OE ₃ to Y, \bar{Y}		18	34		43		51	ns	4.5	Fig.11
t _{PHZ} / t _{PLZ}	3-state output disable time \bar{OE}_n to Y, \bar{Y}		17	33		41		50	ns	4.5	Fig.11
t _{PHZ} / t _{PLZ}	3-state output disable time OE ₃ to Y, \bar{Y}		20	33		41		50	ns	4.5	Fig.11
t _{THL} / t _{TLH}	output transition time		5	12		15		18	ns	4.5	Figs 6, 7 and 8
t _W	clock pulse width CP HIGH or LOW	16	8		20		24		ns	4.5	Fig.6
t _W	latch enable pulse width \bar{LE} LOW	16	6		20		24		ns	4.5	Fig.8
t _{su}	set-up time D _n to CP	10	4		13		15		ns	4.5	Fig.10
t _{su}	set-up time S _n to \bar{LE}	10	5		13		15		ns	4.5	Fig.9
t _h	hold time D _n to CP	5	0		5		5		ns	4.5	Fig.10
t _h	hold time S _n to \bar{LE}	5	-2		5		5		ns	4.5	Fig.9

8-input multiplexer/register; 3-state

74HC/HCT356

AC WAVEFORMS

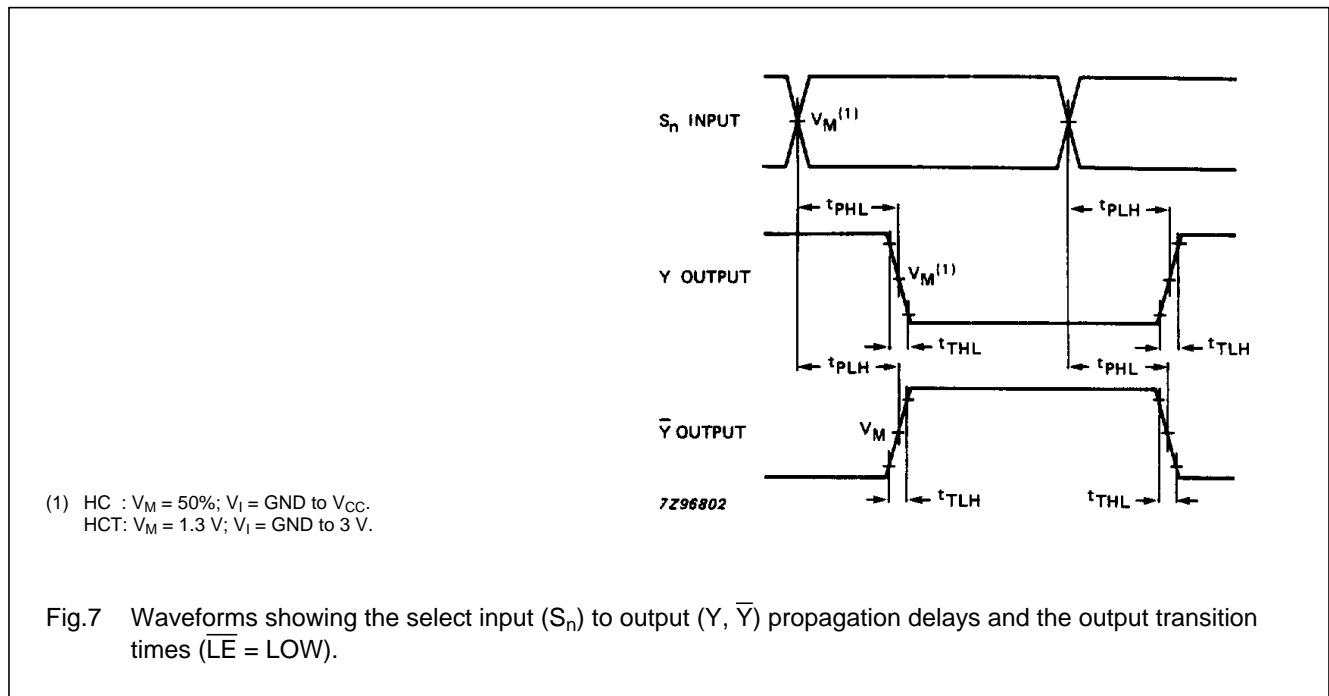
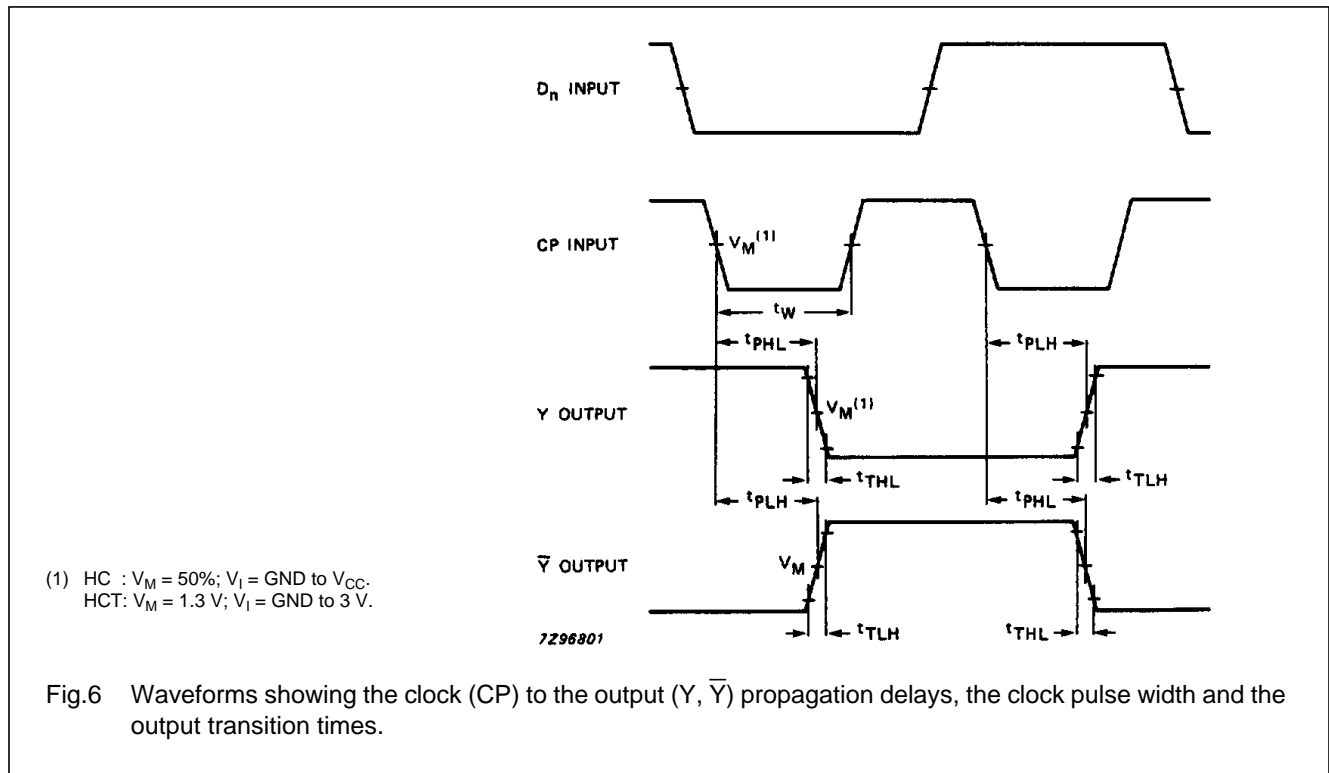

8-input multiplexer/register; 3-state

74HC/HCT356

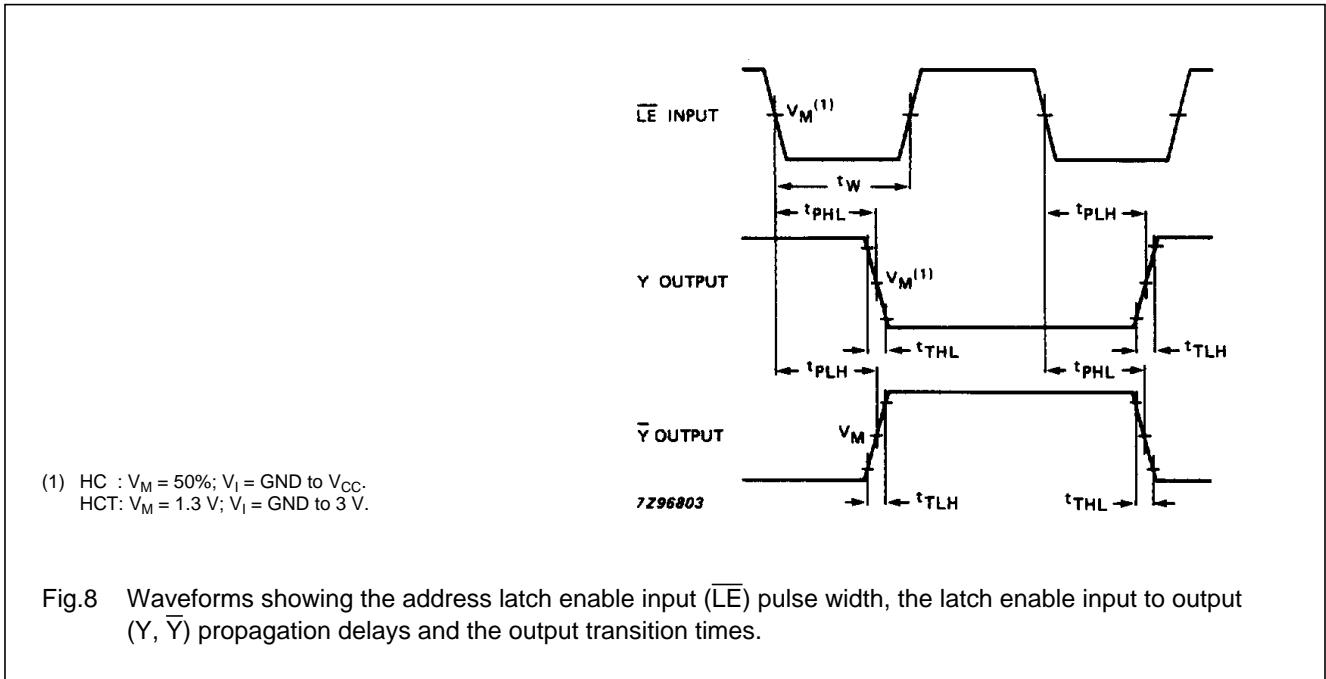

Fig.8 Waveforms showing the address latch enable input ($\overline{\text{LE}}$) pulse width, the latch enable input to output (Y, $\overline{\text{Y}}$) propagation delays and the output transition times.

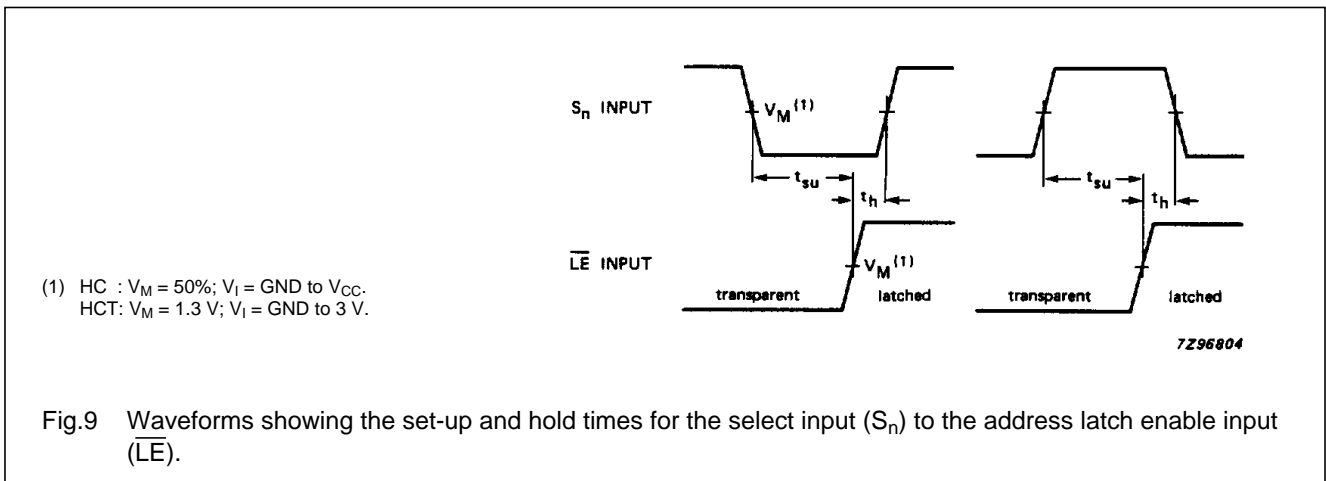

Fig.9 Waveforms showing the set-up and hold times for the select input (S_n) to the address latch enable input ($\overline{\text{LE}}$).

8-input multiplexer/register; 3-state

74HC/HCT356

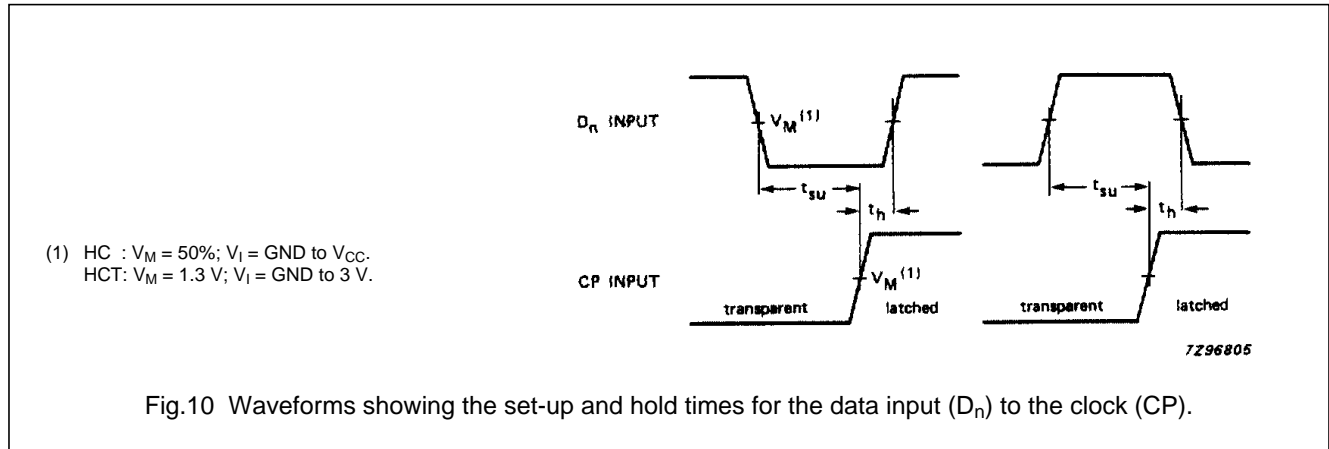

Fig.10 Waveforms showing the set-up and hold times for the data input (D_n) to the clock (CP).

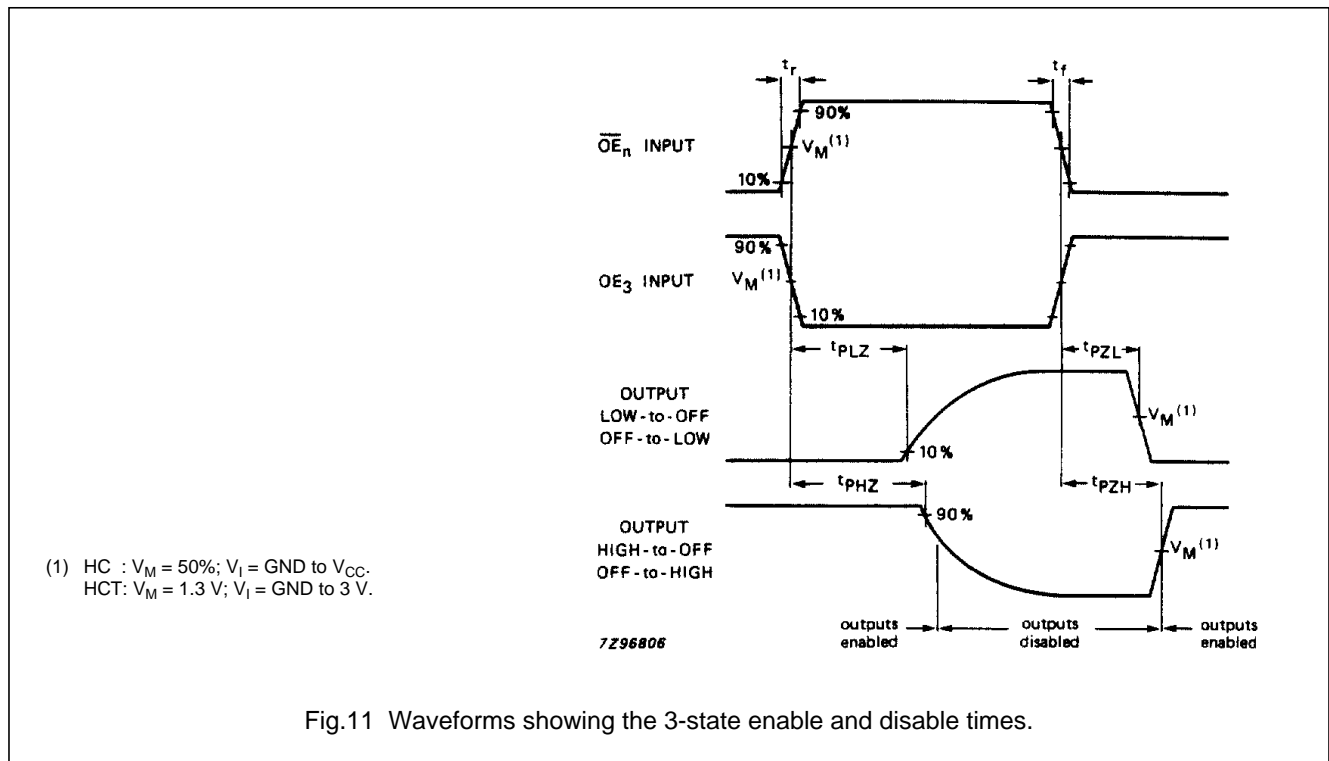

Fig.11 Waveforms showing the 3-state enable and disable times.

PACKAGE OUTLINES

See "74HC/HCT/HCU/HCMOS Logic Package Outlines".



LittleDiode supplies new, hard to find or obsolete electronic components and semiconductors all over the world.

With over two million different components listed you are sure to find the part you need.

Feel free to visit us today at our online store:

LittleDiode.com

Looking forward to providing you with the best possible service.