

FEATURES

Interfaces, amplifies, protects & filters wide-bandwidth (h0 kHz) single-channel analog voltage inputs.

Module provides simultaneous precision voltage and current outputs.

Module circuitry can withstand 130v rms at the current output screw-terminals.

All 3B40 & 3B41 series modules are mix-and-match and Hot Swappable.

APPLICATIONS

Industrial signal conditioning

Industrial signal isolation

Industrial signal filtering

PRODUCT OVERVIEW

The 3B Series of Signal Conditioning I/o Subsystems provide a low-cost, versatile method of transferring analog transducer signals to a data acquisition, monitoring or control system without the inherent noise, non-linearity, drift and extraneous voltages. The modules are designed to directly accept analog signals from Thermocouples, RTD's, AC and DC Strain Gages, Torque Transducers, Frequency Transducers, LVDTs, millivolt or process current signals. The modules amplify, isolate, linearize and convert the transducer output signals to standardized analog inputs for high-level analog I/O subsystems. The 3B Series Subsystem consists of a 10" relay rack with universal mounting backplane and a family of plug-in (up to 16 per rack) input and output signal conditioning modules.

Eight and four channel backplanes are also available. Each backplane incorporates screw terminals for sensor inputs and current outputs and a 26-pin connector for high-level single-ended voltage outputs to the user's equipment.

The input modules feature complete signal conditioning circuitry optimized for specific sensors or analog signals and provide two simultaneous high-level analog outputs: 0 to +10V (or ±10V) and 4-20 mA (or 0-20 mA).

Rev. 0

Information furnished by Analog Devices is believed to be accurate and reliable. However, no responsibility is assumed by Analog Devices for its use, nor for any infringements of patents or other rights of third parties that may result from its use. Specifications subject to change without notice. No license is granted by implication or otherwise under any patent or patent rights of Analog Devices. Trademarks and registered trademarks are the property of their respective companies.

FUNCTIONAL BLOCK DIAGRAM

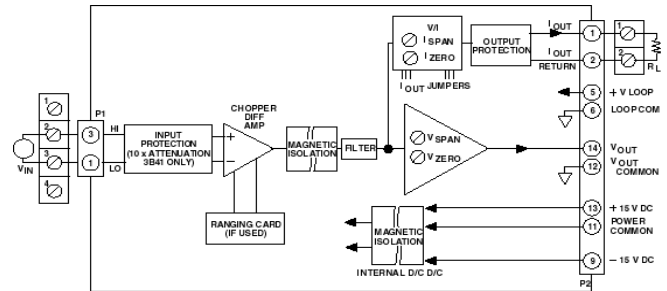

Figure 1. 3B40 & 3B41 Functional Block Diagram

Output modules accept 0 to +10V (or ±10V) single-ended signals and provide an isolated 4-20 mA (or 0-20 mA) process signal. All modules feature a universal pin-out and may be readily hot-swapped under full power and interchanged without disrupting field wiring.

The Analog Devices 3B Series Signal Conditioning Subsystem is designed to easily handle signal conditioning problems in measurement and control applications. Some typical uses are in microcomputer-based data acquisition systems, programmable controllers, analog recorders, dedicated control systems, and any other applications where monitoring of temperature, pressure, flow and analog signals are required. Since each input module features two simultaneous outputs, the voltage output can be used to provide an input to a microprocessor-based data acquisition or control system while the current output can be used for analog transmission, operator interface, or an analog backup system.

Each input module is a single-channel signal conditioner which plugs into a socket on the backplane and accepts its signal from the input screw terminals. All input modules provide input protection, amplification and filtering of the input signal, accuracy of ±0.1%, low drift of ±1 uV/ °C (low-level input modules), and feature two high-level analog outputs that are compatible with most process instrumentation. The isolated input modules also provide ±1500 V peak isolation.

The choice of a specific 3B module depends upon the type of input signal. Input modules are available to accept millivolt, volt, process current, thermocouple, RTD, AC and DC strain gage, frequency and LVDT inputs. The voltage output of each module is available from the system I/O connector while the current output is available on the output screw terminals.

GENERAL DESCRIPTION

The 3B40 and 3B41 are wide-bandwidth (10kHz) single-channel signal conditioning modules which amplify, isolate, filter and protect analog input voltages and provide simultaneous precision voltage and current outputs. Each module performs complete signal conditioning, including isolating (± 1500 V peak input-to-output and power) and protecting their computer side outputs from damage and loss of signal integrity, and shielding their inputs from damage from field-side over-voltage faults up to 220 V rms. The current output withstands 130V rms without damage and interfaces user equipment through screw terminals located on the 3B Series backplane. Each plug-in, mix-and-match, hot-swappable module is easily field calibrated via front-panel zero and span adjustments for both voltage and current outputs.

3B Series Custom-Ranging Program – Externally-programmable versions, Models 3B40-00 and 3B41-00, enable the user to configure a special input range by using the optional plug-on AC1310 ranging card, which houses user-supplied resistors to determine zero and span. To facilitate selecting resistors, a Windows program, 3B-CUSTOM, calculates resistor values based on the user-desired input/output ranges.

A chopper-stabilized low-drift ($\pm 1 \mu\text{V}/^\circ\text{C}$) input amplifier

assures long-term stability. At the amplifier input, a stable, zero-scale input voltage is subtracted from the input signal to set the zero-scale value. Zero suppression can exceed 100% of the input range. This is ideal for expanded-scale applications requiring high-resolution measurement of a selected portion of an input signal. For user convenience, the zero and span can be factory configured to meet custom range needs (Models 3B40-CUSTOM and 3B41-CUSTOM) or can be externally programmed (Models 3B40-00 and 3B41-00) via user supplied resistors inserted in the optional AC1310 plug-on ranging card. Internal low-pass filtering with a 10 kHz cutoff (-3dB) is determined by a two-pole Butterworth filter.

Signal isolation is accomplished by transformer coupling with a proprietary modulation technique for linear, stable and reliable performance. The differential input circuit on the field side is fully floating, eliminating the need for any input grounding. A demodulator on the computer side of the signal transformer recovers the original signal, which is then filtered and buffered to provide a low-noise, low-impedance output voltage; this output also drives a voltage-to-current (V/I) converter to provide a simultaneous current output for interfacing versatility.



Figure 2

3B40 and 3B41 Models Available

Model	Input Range	Output Ranges ¹
3B40-00	Externally Programmable ²	-10 V to +10 V & 0 mA to 20 mA
3B40-01	-10 mV to +10 mV	-10 V to +10 V & 0 mA to 20 mA
3B40-02	-50 mV to +50 mV	-10 V to +10 V & 0 mA to 20 mA
3B40-03	-100 mV to +100 mV	-10 V to +10 V & 0 mA to 20 mA
3B40-Custom	*	*

Model	Input Range	Output Ranges ¹
3B41-00	Externally Programmable ²	-10 V to +10 V & 0 mA to 20 mA
3B41-01	-1 V to +1 V	-10 V to +10 V & 0 mA to 20 mA
3B41-02	-5 V to +5 V	-10 V to +10 V & 0 mA to 20 mA
3B41-03	-10 V to +10 V	-10 V to +10 V & 0 mA to 20 mA
3B41-Custom	*	*

¹ Output current range may be user programmed to 4 mA to 20 mA using jumper supplied.

² Requires AC1310 ranging card.

* Custom Input/Output ranges are available. Refer to configuration guide.

3B40 and 3B41 Specifications (typical @ +25°C and ±15 V dc, and +24 V dc Power)

Description	Model 3B40	Model 3B41
Input Ranges		
Standard Ranges	±10 mV to ±1 V	±1 mV to ±10 V
Custom Ranges	±5 mV to ±1 V	±0.5 V to ±20 V
Output Ranges		
Voltage ($R_L > 2 \text{ k}\Omega$)	-10 V to +10 V	*
Current ($R_L = 0 \text{ to } 850 \Omega$) ¹	4 mA to 20 mA or 0 mA to 20 mA	*
Maximum Current Output Span	0 mA to 31 mA	*
Accuracy²		
Initial @ +25°C	±0.1% Span	*
Nonlinearity	±0.02% Span	*
Stability vs. Temperature		
Voltage Output		
Input Zero	±2 $\mu\text{V}/^\circ\text{C}$ (RTI)	±10 $\mu\text{V}/^\circ\text{C}$ (RTI)
Output Zero	±25 $\mu\text{V}/^\circ\text{C}$ (RTI)	*
Span	±25 ppm of Reading/ $^\circ\text{C}$	*
Zero and Span Adjustment Range⁴	±5% of Span	*
Input Bias Current	=5 nA	*
Input Resistance	200 M Ω	250 k Ω
Input, 10 MHz Bandwidth	5 μV rms	*

Output, Ripple and Noise	25 mV peak-to-peak	*
Bandwidth, -3 dB	10 kHz	*
Output Rise Time, 10% to 90% Span	55 μ s	*
Common-Mode Voltage (CMV)		
Input-to-Output, Continuous	\pm 1500 V peak, maximum	*
Transient	ANSI/IEEE C37.90.1-1989	*
Common Mode Rejection (CMR)		
1 k Ω Source Imbalance, 50/60 Hz	100 dB	85 dB
Input Protection		
Continuous	220 V rms, maximum	*
Transient	ANSI/IEEE C37.90.1-1989	*
Voltage Output Protection	Continuous Short to Ground	*
Current Output Protection	130 V rms, continuous	*
Power Supply Voltages ⁵		
\pm15 V dc Supplies		
Rated Operation	\pm (11.5 V dc to 16.5 V dc)	*
Current	\pm 10 mA	*
Sensitivity	\pm 0.01% span/V	*
+24 V dc Loop Supply		
Rated Operation	+12 V dc to +30 V dc	*
Current	+27 mA @ $I_{out} = 20$ mA	*
Sensitivity	\pm 0.0002% span/V	*
Mechanical Dimensions	3.15" x 3.395" x 0.775" (80.0 mm x 86.2 mm x 19.7 mm)	*
Environmental		
Temperature Range		
Rated Performance	-25°C to +85°C	*
Storage	-55°C to +85°C	*
Relative Humidity, 24 hours	0 to 95% @ +60°C non-condensing	*
RFI Susceptibility	\pm 0.5% Span error @ 400 MHz, 5 Watt, 3 ft	*

*Specifications same as model 3B40.

¹ For a 0 to 20 mA range, a typical minimum output current is 10 μ A.

² Includes the combined effects of repeatability, hysteresis, and nonlinearity.

³ With respect to the voltage output.

⁴ A wide range of custom zero suppression and span is available with the 3B40-00 and 3B41-00 models, using the AC1310 ranging card.

⁵ +24 V dc loop power is required for driving the current output at loads up to 850 Ω . If a current output load of 400 Ω or less is applied, +15 V dc is sufficient for loop power. If only voltage output is used, loop power is not required. *Specifications subject to change without notice.*

PIN CONFIGURATIONS AND FUNCTIONAL DESCRIPTIONS

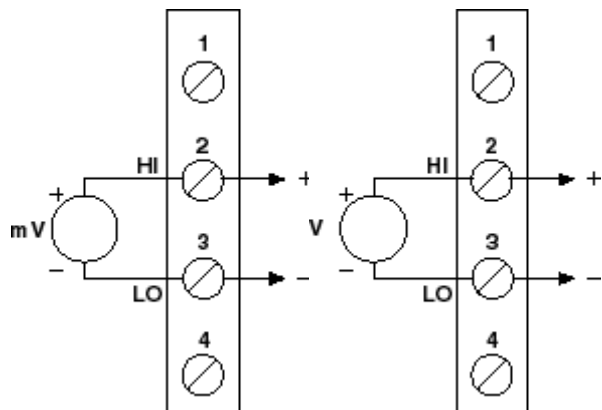

Figure 3 3B40 & 3B41 Input Field Connections

Table 1. Pin Function Descriptions—

Pin No.	Description
1	N/C
2	HI
3	LO
4	N/C

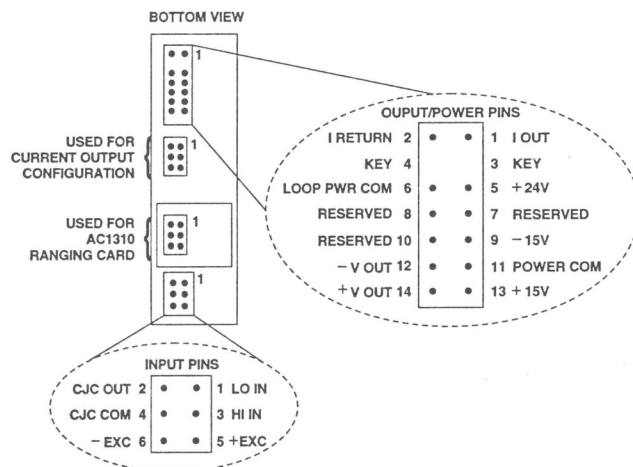

Figure 4 . Model 3B Series Module, with pin-out assignments.

ESD CAUTION

ESD (electrostatic discharge) sensitive device. Electrostatic charges as high as 4000 V readily accumulate on the human body and test equipment and can discharge without detection. Although this product features proprietary ESD protection circuitry, permanent damage may occur on devices subjected to high energy electrostatic discharges. Therefore, proper ESD precautions are recommended to avoid performance degradation or loss of functionality.



OUTLINE DIMENSIONS

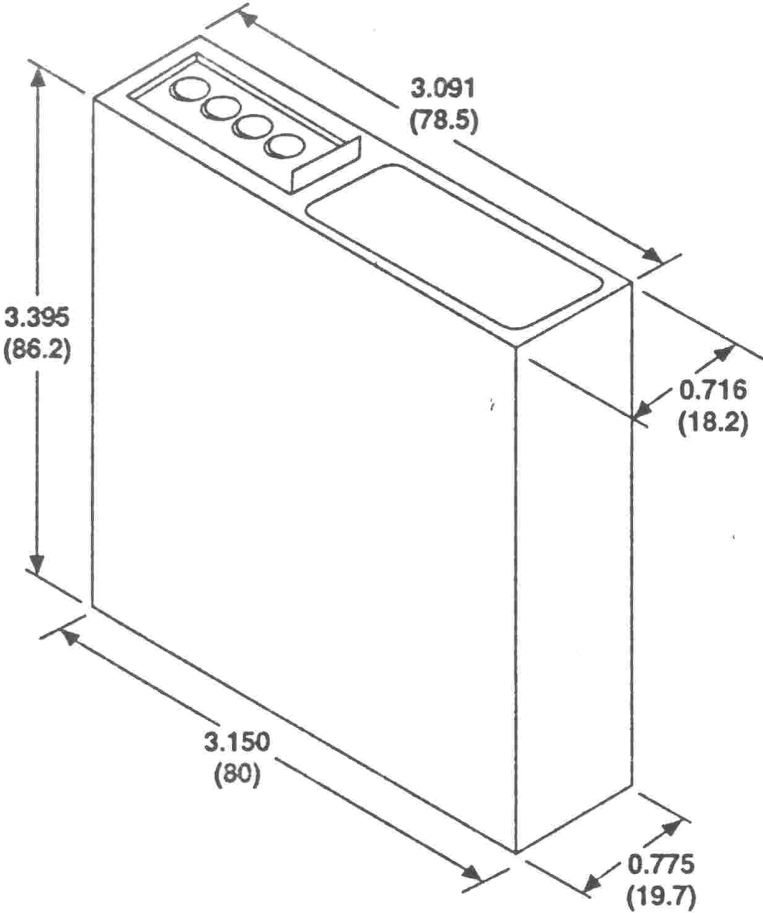

Figure 5. Outline Dimensions

NOTES

NOTES



LittleDiode supplies new, hard to find or obsolete electronic components and semiconductors all over the world.

With over two million different components listed you are sure to find the part you need.

Feel free to visit us today at our online store:

LittleDiode.com

Looking forward to providing you with the best possible service.