

# SN5454, SN54LS54, SN7454, SN74LS54 4-WIDE AND-OR-INVERT GATES

SDLS115

DECEMBER 1983—REVISED MARCH 1988

- Package Options Include Plastic "Small Outline" Packages, Ceramic Chip Carriers and Flat Packages, and Plastic and Ceramic DIPs
- Dependable Texas Instruments Quality and Reliability

## description

These devices contain 4-wide AND-OR-INVERT gates. They perform the following Boolean functions:

$$\begin{aligned} \text{'54 } Y &= \overline{AB + CD + EF + GH} \\ \text{LS54 } Y &= \overline{AB + CDE + FGH + IJ} \end{aligned}$$

The SN5454 and SN54LS54 are characterized for operation over the full military temperature range of  $-55^{\circ}\text{C}$  to  $125^{\circ}\text{C}$ . The SN7454 and SN74LS54 are characterized for operation from  $0^{\circ}\text{C}$  to  $70^{\circ}\text{C}$ .

## logic diagrams (positive logic)

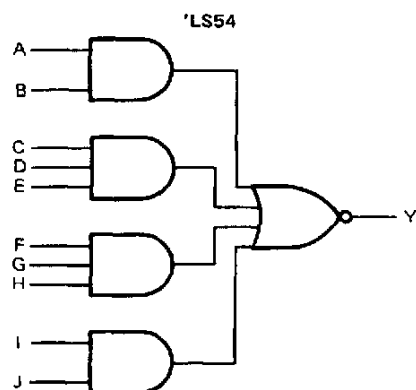
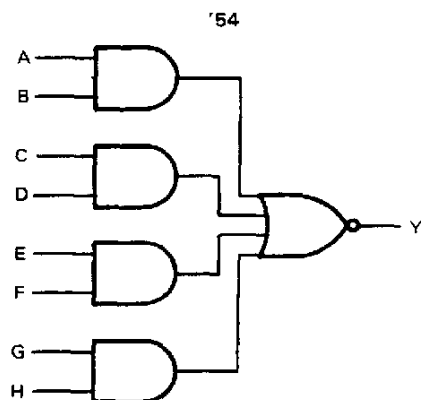

SN5454 . . . J PACKAGE  
SN7454 . . . N PACKAGE  
(TOP VIEW)

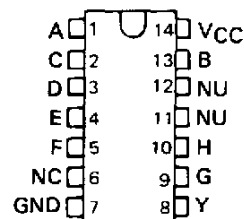

SN5454 . . . W PACKAGE  
(TOP VIEW)

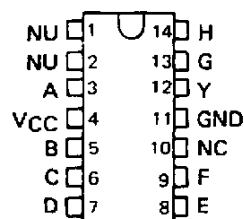

SN54LS54 . . . J OR W PACKAGE  
SN74LS54 . . . D OR N PACKAGE  
(TOP VIEW)

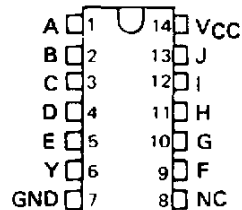

SN54LS54 . . . FK PACKAGE  
(TOP VIEW)

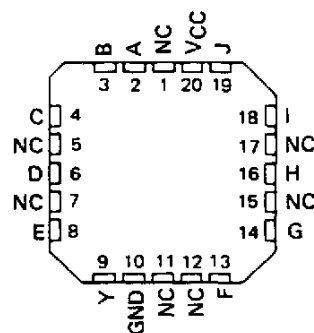

NC—No internal connection  
NU—Make no external connection

PRODUCTION DATA documents contain information current as of publication date. Products conform to specifications per the terms of Texas Instruments standard warranty. Production processing does not necessarily include testing of all parameters.

TEXAS  
INSTRUMENTS

POST OFFICE BOX 655012 • DALLAS, TEXAS 75265

# SN5454, SN54LS54, SN7454, SN74LS54

## 4-WIDE AND-OR-INVERT GATES

### logic symbols†

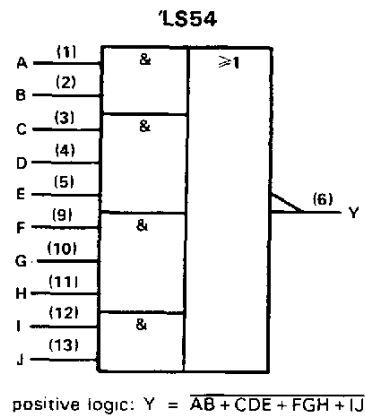
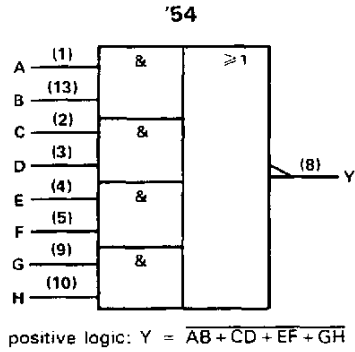

†These symbols are in accordance with ANSI/IEEE Std 91-1984 and IEC Publication 617-12. Pin numbers shown are for D, J, and N package. For the SN54LS54 only, they apply also for the W package.

### schematics

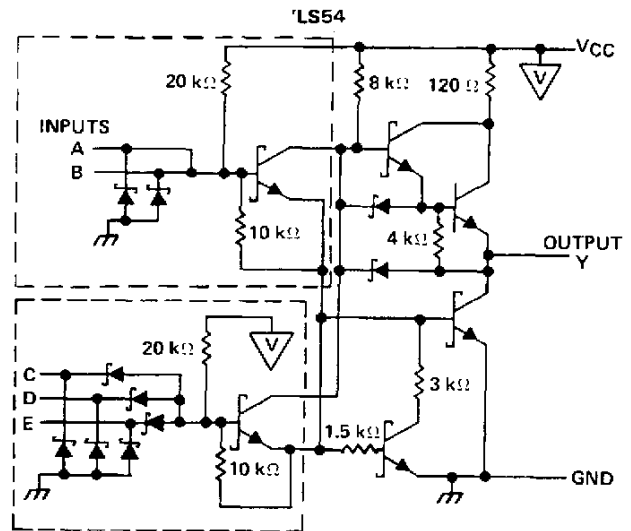
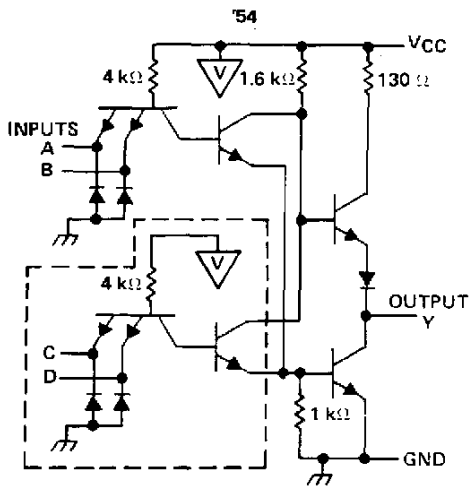

Resistor values shown are nominal.

The portion of the circuits within the dashed lines is repeated for each additional 2- or 3-input AND section, as shown in the logic diagram and logic symbols.

## SN5454, SN7454 4-WIDE AND-OR-INVERT GATES

### absolute maximum ratings over operating free-air temperature range (unless otherwise noted)

Supply voltage, $V_{CC}$ (see Note 1)	7 V
Input voltage	5.5 V
Operating free-air temperature: SN5454	-55°C to 125°C
SN7454	0°C to 70°C
Storage temperature range	-65°C to 150°C

NOTE 1: Voltage values are with respect to network ground terminal.

### recommended operating conditions

	SN5454			SN7454			UNIT
	MIN	NOM	MAX	MIN	NOM	MAX	
$V_{CC}$ Supply voltage	4.5	5	5.5	4.75	5	5.25	V
$V_{IH}$ High-level input voltage	2			2			V
$V_{IL}$ Low-level input voltage			0.8			0.8	V
$I_{OH}$ High-level output current			-0.4			-0.4	mA
$I_{OL}$ Low-level output current			16			16	mA
$T_A$ Operating free-air temperature	-55		125	0		70	°C

### electrical characteristics over recommended operating free-air temperature range (unless otherwise noted)

PARAMETER	TEST CONDITIONS <sup>†</sup>	SN5454			SN7454			UNIT
		MIN	TYP <sup>‡</sup>	MAX	MIN	TYP <sup>‡</sup>	MAX	
$V_{IK}$	$V_{CC} = \text{MIN.}$ , $I_I = -12 \text{ mA}$			-1.5			-1.5	V
$V_{OH}$	$V_{CC} = \text{MIN.}$ , $V_{IL} = 0.8 \text{ V}$ , $I_{OH} = -0.4 \text{ mA}$	2.4	3.4		2.4	3.4		V
$V_{OL}$	$V_{CC} = \text{MIN.}$ , $V_{IH} = 2 \text{ V}$ , $I_{OL} = 16 \text{ mA}$		0.2	0.4		0.2	0.4	V
$I_I$	$V_{CC} = \text{MAX.}$ , $V_I = 5.5 \text{ V}$			1			1	mA
$I_{IH}$	$V_{CC} = \text{MAX.}$ , $V_I = 2.4 \text{ V}$			40			40	μA
$I_{IL}$	$V_{CC} = \text{MAX.}$ , $V_I = 0.4 \text{ V}$			-1.6			-1.6	mA
$I_{OS}§$	$V_{CC} = \text{MAX.}$	-20		-55	-18		-55	mA
$I_{CCH}$	$V_{CC} = \text{MAX.}$ , $V_I = 0 \text{ V}$		4	8		4	8	mA
$I_{CCL}$	$V_{CC} = \text{MAX.}$ , See Note 2		5.1	9.5		5.1	9.5	mA

<sup>†</sup> For conditions shown as MIN or MAX, use the appropriate value specified under recommended operating conditions.

<sup>‡</sup> All typical values are at  $V_{CC} = 5 \text{ V}$ ,  $T_A = 25^\circ\text{C}$ .

<sup>§</sup> Not more than one output should be shorted at a time.

NOTE 2: All inputs of one AND gate at 4.5 V, all others at GND.

### switching characteristics, $V_{CC} = 5 \text{ V}$ , $T_A = 25^\circ\text{C}$ (see note 3)

PARAMETER	FROM (INPUT)	TO (OUTPUT)	TEST CONDITIONS	MIN	TYP	MAX	UNIT
$t_{PLH}$	Any	Y	$R_L = 400 \Omega$ , $C_L = 15 \text{ pF}$		13	22	ns
$t_{PHL}$					8	15	ns

NOTE 3: Load circuits and voltage waveforms are shown in Section 1.

# SN54LS54, SN74LS54 4-WIDE AND-OR-INVERT GATES

## absolute maximum ratings over operating free-air temperature range (unless otherwise noted)

Supply voltage, $V_{CC}$ (see Note 1)	7 V
Input voltage	7 V
Operating free-air temperature: SN54LS54	-55°C to 125°C
SN74LS54	0°C to 70°C
Storage temperature range	-65°C to 150°C

NOTE 1: Voltage values are with respect to network ground terminal.

## recommended operating conditions

	SN54LS54			SN74LS54			UNIT
	MIN	NOM	MAX	MIN	NOM	MAX	
$V_{CC}$ Supply voltage	4.5	5	5.5	4.75	5	5.25	V
$V_{IH}$ High-level input voltage	2			2			V
$V_{IL}$ Low-level input voltage			0.7			0.8	V
$I_{OH}$ High-level output current			-0.4			-0.4	mA
$I_{OL}$ Low-level output current			4			8	mA
$T_A$ Operating free-air temperature	-55		125	0		70	°C

## electrical characteristics over recommended operating free-air temperature range (unless otherwise noted)

PARAMETER	TEST CONDITIONS†	SN54LS54		SN74LS54		UNIT		
		MIN	TYP ‡	MAX	MIN		TYP ‡	MAX
$V_{IK}$	$V_{CC} = \text{MIN}, I_I = -18 \text{ mA}$			-1.5		-1.5	V	
$V_{OH}$	$V_{CC} = \text{MIN}, V_{IL} = \text{MAX}, I_{OH} = -0.4 \text{ mA}$	2.5	3.4		2.7	3.4	V	
$V_{OL}$	$V_{CC} = \text{MIN}, V_{IH} = 2 \text{ V}, I_{OL} = 4 \text{ mA}$		0.25	0.4		0.25	0.4	V
	$V_{CC} = \text{MIN}, V_{IH} = 2 \text{ V}, I_{OL} = 8 \text{ mA}$					0.35	0.5	V
$I_I$	$V_{CC} = \text{MAX}, V_I = 7 \text{ V}$			0.1		0.1	mA	
$I_{IH}$	$V_{CC} = \text{MAX}, V_I = 2.7 \text{ V}$			20		20	µA	
$I_{IL}$	$V_{CC} = \text{MAX}, V_I = 0.4 \text{ V}$			-0.4		-0.4	mA	
$I_{OS}§$	$V_{CC} = \text{MAX}$	-20		-100	-20	-100	mA	
$I_{CCH}$	$V_{CC} = \text{MAX}, V_I = 0 \text{ V}$		0.8	1.6		0.8	1.6	mA
$I_{CCL}$	$V_{CC} = \text{MAX}, \text{ See Note 2}$		1	2		1	2	mA

† For conditions shown as MIN or MAX, use the appropriate value specified under recommended operating conditions.

‡ All typical values are at  $V_{CC} = 5 \text{ V}, T_A = 25^\circ \text{C}$ .

§ Not more than one output should be shorted at a time, and the duration of the short-circuit should not exceed one second.

NOTE 2: All inputs of one AND gate at 4.5 V, all others at GND.

## switching characteristics, $V_{CC} = 5 \text{ V}, T_A = 25^\circ \text{C}$ (see note 3)

PARAMETER	FROM (INPUT)	TO (OUTPUT)	TEST CONDITIONS	MIN	TYP	MAX	UNIT
$t_{PLH}$	Any	Y	$R_L = 2 \text{ k}\Omega, C_L = 15 \text{ pF}$		12	20	ns
$t_{PHL}$					12.5	20	ns

NOTE 3: Load circuits and voltage waveforms are shown in Section 1.

## IMPORTANT NOTICE

Texas Instruments and its subsidiaries (TI) reserve the right to make changes to their products or to discontinue any product or service without notice, and advise customers to obtain the latest version of relevant information to verify, before placing orders, that information being relied on is current and complete. All products are sold subject to the terms and conditions of sale supplied at the time of order acknowledgement, including those pertaining to warranty, patent infringement, and limitation of liability.

TI warrants performance of its semiconductor products to the specifications applicable at the time of sale in accordance with TI's standard warranty. Testing and other quality control techniques are utilized to the extent TI deems necessary to support this warranty. Specific testing of all parameters of each device is not necessarily performed, except those mandated by government requirements.

CERTAIN APPLICATIONS USING SEMICONDUCTOR PRODUCTS MAY INVOLVE POTENTIAL RISKS OF DEATH, PERSONAL INJURY, OR SEVERE PROPERTY OR ENVIRONMENTAL DAMAGE ("CRITICAL APPLICATIONS"). TI SEMICONDUCTOR PRODUCTS ARE NOT DESIGNED, AUTHORIZED, OR WARRANTED TO BE SUITABLE FOR USE IN LIFE-SUPPORT DEVICES OR SYSTEMS OR OTHER CRITICAL APPLICATIONS. INCLUSION OF TI PRODUCTS IN SUCH APPLICATIONS IS UNDERSTOOD TO BE FULLY AT THE CUSTOMER'S RISK.

In order to minimize risks associated with the customer's applications, adequate design and operating safeguards must be provided by the customer to minimize inherent or procedural hazards.

TI assumes no liability for applications assistance or customer product design. TI does not warrant or represent that any license, either express or implied, is granted under any patent right, copyright, mask work right, or other intellectual property right of TI covering or relating to any combination, machine, or process in which such semiconductor products or services might be or are used. TI's publication of information regarding any third party's products or services does not constitute TI's approval, warranty or endorsement thereof.

This datasheet has been downloaded from:

[www.DatasheetCatalog.com](http://www.DatasheetCatalog.com)

Datasheets for electronic components.

# Texas Instruments

<http://www.ti.com>

This file is the datasheet for the following electronic components:

SN74LS54D - <http://www.ti.com/product/sn74ls54d?HQS=TI-null-null-dscatalog-df-pf-null-wwe>

SN5454W - <http://www.ti.com/product/sn5454w?HQS=TI-null-null-dscatalog-df-pf-null-wwe>

SN7454 - <http://www.ti.com/product/sn7454?HQS=TI-null-null-dscatalog-df-pf-null-wwe>

SN54LS54FK - <http://www.ti.com/product/sn54ls54fk?HQS=TI-null-null-dscatalog-df-pf-null-wwe>

SN74LS54N - <http://www.ti.com/product/sn74ls54n?HQS=TI-null-null-dscatalog-df-pf-null-wwe>

SN54LS54W - <http://www.ti.com/product/sn54ls54w?HQS=TI-null-null-dscatalog-df-pf-null-wwe>

SN74LS54 - <http://www.ti.com/product/sn74ls54?HQS=TI-null-null-dscatalog-df-pf-null-wwe>

74LS54 - <http://www.ti.com/product/74ls54?HQS=TI-null-null-dscatalog-df-pf-null-wwe>

SN7454N - <http://www.ti.com/product/sn7454n?HQS=TI-null-null-dscatalog-df-pf-null-wwe>



LittleDiode supplies new, hard to find or obsolete electronic components and semiconductors all over the world.

With over two million different components listed you are sure to find the part you need.

Feel free to visit us today at our online store:

[LittleDiode.com](http://LittleDiode.com)

Looking forward to providing you with the best possible service.