

HD74LS93 4-bit Binary Counters

The HD74LS93 contains four master-slave flip-flops and additional gating to provide a divide-by-two counter and three-state binary counter for divide-by-eight. To use this maximum count length of this counter, the B input is connected to the Q_A output. The input count pulses are applied to the Q_A output. The input count pulses are described in the appropriate function table.

■ BLOCK DIAGRAM

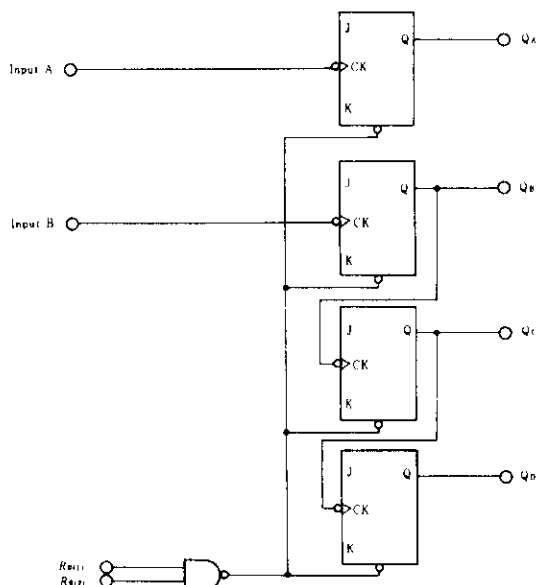

■ RECOMMENDED OPERATING CONDITIONS

Item	Symbol	min	typ	max	Unit
Count frequency	A input	0	—	32	MHz
	B input	0	—	16	
Pulse width	A input	15	—	—	ns
	B input	30	—	—	
	Reset inputs	15	—	—	
Setup time	t_{su}	25	—	—	ns

■ TIMING DEFINITION

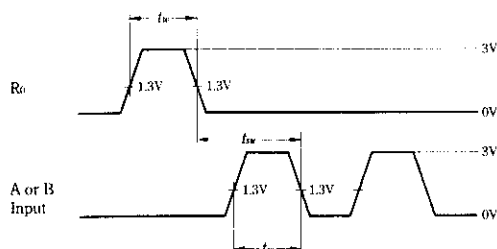

■ PIN ARRANGEMENT

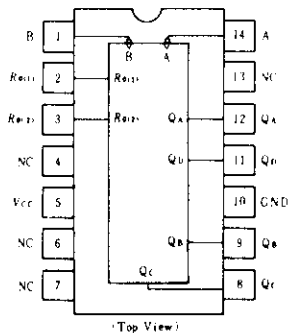

■ ABSOLUTE MAXIMUM RATINGS

Item	Symbol	Ratings	Unit
Supply voltage	V_{CC}	7.0	V
Input voltage	R Inputs	7.0	V
	A, B Inputs	5.5	V
Operating temperature range	T_{opr}	-20 ~ +75	°C
Storage temperature range	T_{stg}	-65 ~ +150	°C

■ FUNCTION TABLE

● Reset/Count Function Table

Reset Inputs		Outputs			
R0(1)	R0(2)	QD	QC	QB	QA
H	H	L	L	L	L
L	X	Count			
X	L	Count			

● BCD Count Sequence (Notes 1)

Count	Outputs			
	QD	QC	QB	QA
0	L	L	L	L
1	L	L	L	H
2	L	L	H	L
3	L	L	H	H
4	L	H	L	L
5	L	H	L	H
6	L	H	H	L
7	L	H	H	H
8	H	L	L	L
9	H	L	L	H
10	H	L	H	L
11	H	L	H	H
12	H	H	L	L
13	H	H	L	H
14	H	H	H	L
15	H	H	H	H

Notes) 1. Output Q_A is connected to input B for BCD count.
2. H; high level, L; low level, X; irrelevant

■ ELECTRICAL CHARACTERISTICS ($T_a = -20 \sim +75^\circ\text{C}$)

Item	Symbol	Test Conditions	min	typ*	max	Unit		
Input voltage	V_{IH}		2.0	—	—	V		
	V_{IL}		—	—	0.8	V		
Output voltage	V_{OH}	$V_{CC}=4.75\text{V}, V_{IH}=2\text{V}, V_{IL}=0.8\text{V}, I_{OH}=-400\mu\text{A}$	2.7	—	—	V		
	V_{OL}	$V_{CC}=4.75\text{V}, V_{IH}=2\text{V}, V_{IL}=0.8\text{V}$	$I_{OL}=4\text{mA}^{**}$	—	—	0.4	V	
			$I_{OL}=8\text{mA}^{**}$	—	—	0.5		
Input current	Any Reset	I_{IL}	$V_{CC}=5.25\text{V}, V_I=0.4\text{V}$	—	—	-0.4	mA	
	A input			—	—	-2.4		
	B input			—	—	-1.6		
	Any Reset	I_{IH}	$V_{CC}=5.25\text{V}, V_I=2.7\text{V}$	—	—	20	μA	
	A input			—	—	40		
	B input			—	—	40		
	Any Reset	I_I	$V_{CC}=5.25\text{V}$	$V_I=7\text{V}$	—	—	0.1	mA
	A input			$V_I=5.5\text{V}$	—	—	0.2	
B input	$V_I=5.5\text{V}$			—	—	0.2		
Short-circuit output current	I_{OS}	$V_{CC}=5.25\text{V}$	-20	—	-100	mA		
Supply current	I_{CC}^{***}	$V_{CC}=5.25\text{V}$	—	9	15	mA		
Input clamp voltage	V_{IK}	$V_{CC}=4.75\text{V}, I_{IN}=-18\text{mA}$	—	—	-1.5	V		

* $V_{CC}=5\text{V}, T_a=25^\circ\text{C}$

** Q_A output is tested at specified I_{OL} plus the limit value of I_{IL} for the B input. This permits driving the B input while maintaining full fan-out capability.

*** I_{CC} is measured with all outputs open, both R_0 inputs grounded following momentary connection to 4.5V, and all other inputs grounded.

■ SWITCHING CHARACTERISTICS ($V_{CC}=5\text{V}, T_a=25^\circ\text{C}$)

Item	Symbol	Inputs	Outputs	Test Conditions	min	typ	max	Unit
Maximum count frequency	f_{max}	A	Q_A	$C_L=15\text{pF}, R_L=2\text{k}\Omega$	32	42	—	MHz
		B	Q_B		16	—	—	
Propagation delay time	t_{PLH}	A	Q_A		—	10	16	ns
	t_{PHL}				—	12	18	
	t_{PLH}	A	Q_D		—	46	70	ns
	t_{PHL}				—	46	70	
	t_{PLH}	B	Q_B		—	10	16	ns
	t_{PHL}				—	14	21	
	t_{PLH}	B	Q_C		—	21	32	ns
	t_{PHL}				—	23	35	
	t_{PLH}	B	Q_D	—	34	51	ns	
	t_{PHL}			—	34	51		
t_{PHL}		Set-to-0	$Q_A \sim Q_D$	—	26	40	ns	

HD74LS93

TESTING METHOD

1) Test Circuit

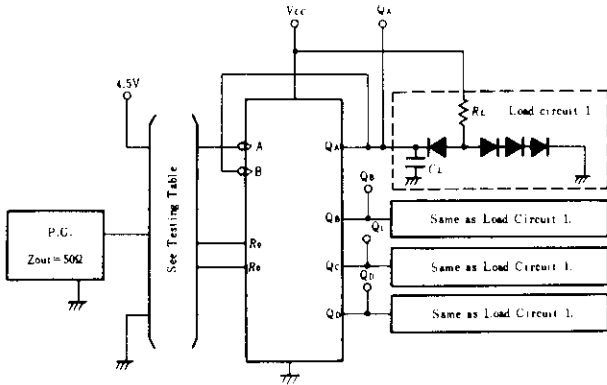

- Notes) 1. C_L includes probe and jig capacitance.
2. All diodes are 1S2074 (D).

2) Testing Table

Item	From input to output	Inputs			Outputs			
		A	B	R_0	Q_A	Q_B	Q_C	Q_D
f_{max}	A → Q	IN	to Q_A	GND	Out	Out	Out	Out
	B → Q	4.5V	IN	GND	—	Out	Out	Out
t_{PLH}	A → Q_A	IN	to Q_A	GND	Out	—	—	—
	A → Q_D	IN	to Q_A	GND	—	—	—	Out
t_{PHL}	B → Q_B	4.5V	IN	GND	—	Out	—	—
	B → Q_C	4.5V	IN	GND	—	—	Out	—
	B → Q_D	4.5V	IN	GND	—	—	—	Out
	$R_0^* \rightarrow Q$	IN*	to Q_A	IN	Out	Out	Out	Out

- * For initialized.
** Measured with each input and unused inputs at 4.5V.

Waveform-1 f_{max} , t_{PLH} , t_{PHL} , (Clock → Q)

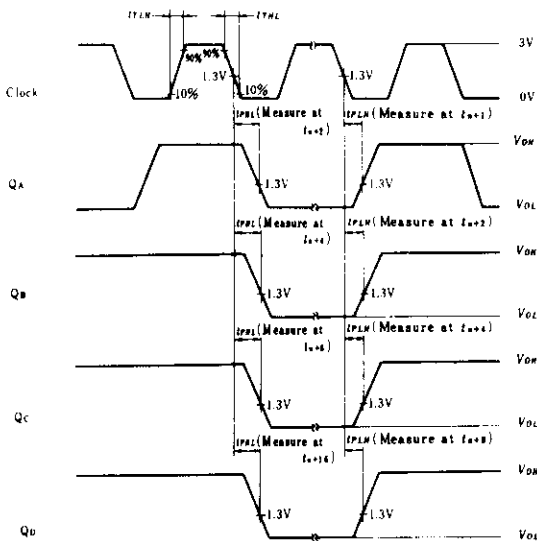

- Notes) 1. Input pulse; $t_{TLH} \leq 15ns$, $t_{THL} \leq 5ns$, $PRR=1MHz$, duty cycle=50% and for f_{max} , $t_{TLH}=t_{THL} \leq 2.5ns$.
2. t_H is reference bit time when all outputs are low.

Waveform-2 $t_{PHL}(R_0 \rightarrow Q)$

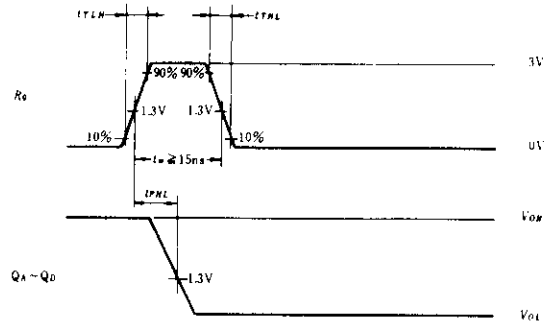

- Notes) 1. $t_{TLH} \leq 15ns$, $t_{THL} \leq 5ns$.

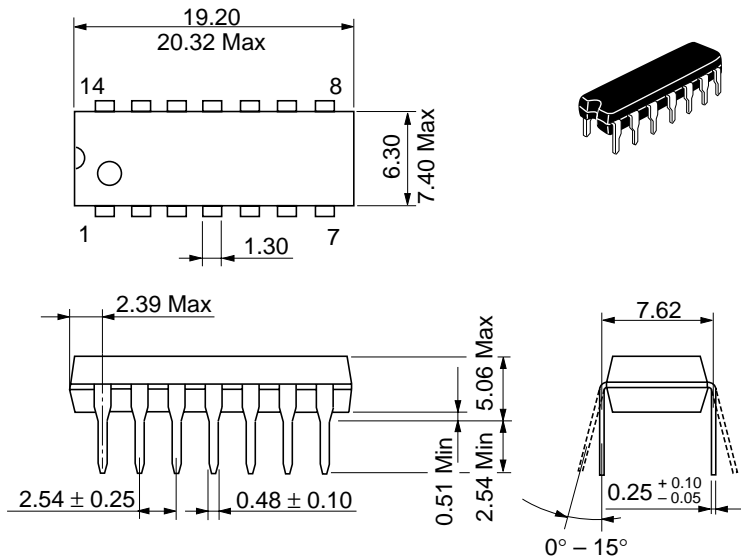

Hitachi Code	DP-14
JEDEC	Conforms
EIAJ	Conforms
Weight (reference value)	0.97 g

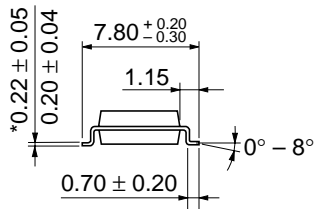
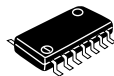
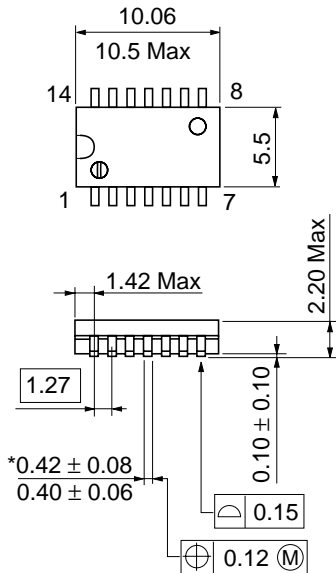

Hitachi Code	FP-14DA
JEDEC	—
EIAJ	Conforms
Weight (reference value)	0.23 g

*Dimension including the plating thickness
Base material dimension

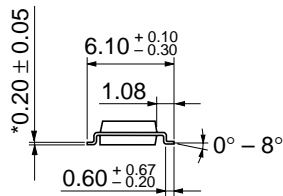
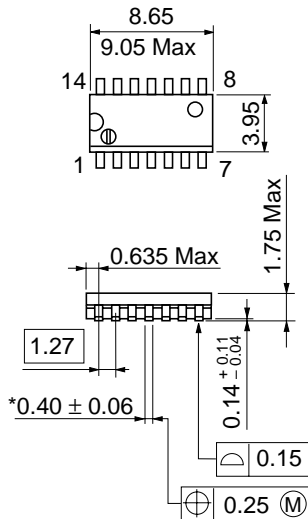

Hitachi Code	FP-14DN
JEDEC	Conforms
EIAJ	Conforms
Weight (reference value)	0.13 g

Cautions

1. Hitachi neither warrants nor grants licenses of any rights of Hitachi's or any third party's patent, copyright, trademark, or other intellectual property rights for information contained in this document. Hitachi bears no responsibility for problems that may arise with third party's rights, including intellectual property rights, in connection with use of the information contained in this document.
2. Products and product specifications may be subject to change without notice. Confirm that you have received the latest product standards or specifications before final design, purchase or use.
3. Hitachi makes every attempt to ensure that its products are of high quality and reliability. However, contact Hitachi's sales office before using the product in an application that demands especially high quality and reliability or where its failure or malfunction may directly threaten human life or cause risk of bodily injury, such as aerospace, aeronautics, nuclear power, combustion control, transportation, traffic, safety equipment or medical equipment for life support.
4. Design your application so that the product is used within the ranges guaranteed by Hitachi particularly for maximum rating, operating supply voltage range, heat radiation characteristics, installation conditions and other characteristics. Hitachi bears no responsibility for failure or damage when used beyond the guaranteed ranges. Even within the guaranteed ranges, consider normally foreseeable failure rates or failure modes in semiconductor devices and employ systemic measures such as fail-safes, so that the equipment incorporating Hitachi product does not cause bodily injury, fire or other consequential damage due to operation of the Hitachi product.
5. This product is not designed to be radiation resistant.
6. No one is permitted to reproduce or duplicate, in any form, the whole or part of this document without written approval from Hitachi.
7. Contact Hitachi's sales office for any questions regarding this document or Hitachi semiconductor products.

HITACHI

Hitachi, Ltd.

Semiconductor & Integrated Circuits.
Nippon Bldg., 2-6-2, Ohte-machi, Chiyoda-ku, Tokyo 100-0004, Japan
Tel: Tokyo (03) 3270-2111 Fax: (03) 3270-5109

URL North America : <http://semiconductor.hitachi.com/>
 Europe : <http://www.hitachi-eu.com/hel/ecg>
 Asia (Singapore) : <http://www.has.hitachi.com.sg/grp3/sicd/index.htm>
 Asia (Taiwan) : http://www.hitachi.com.tw/E/Product/SICD_Frame.htm
 Asia (HongKong) : <http://www.hitachi.com.hk/eng/bo/grp3/index.htm>
 Japan : <http://www.hitachi.co.jp/Sicd/indx.htm>

For further information write to:

Hitachi Semiconductor
(America) Inc.
179 East Tasman Drive,
San Jose, CA 95134
Tel: <1> (408) 433-1990
Fax: <1> (408) 433-0223

Hitachi Europe GmbH
Electronic components Group
Dornacher Straße 3
D-85622 Feldkirchen, Munich
Germany
Tel: <49> (89) 9 9180-0
Fax: <49> (89) 9 29 30 00

Hitachi Europe Ltd.
Electronic Components Group.
Whitebrook Park
Lower Cookham Road
Maidenhead
Berkshire SL6 8YA, United Kingdom
Tel: <44> (1628) 585000
Fax: <44> (1628) 778322

Hitachi Asia Pte. Ltd.
16 Collyer Quay #20-00
Hitachi Tower
Singapore 049318
Tel: 535-2100
Fax: 535-1533

Hitachi Asia Ltd.
Taipei Branch Office
3F, Hung Kuo Building, No.167,
Tun-Hwa North Road, Taipei (105)
Tel: <886> (2) 2718-3666
Fax: <886> (2) 2718-8180

Hitachi Asia (Hong Kong) Ltd.
Group III (Electronic Components)
7/F., North Tower, World Finance Centre,
Harbour City, Canton Road, Tsim Sha Tsui,
Kowloon, Hong Kong
Tel: <852> (2) 735 9218
Fax: <852> (2) 730 0281
Telex: 40815 HITEC HX

Copyright ' Hitachi, Ltd., 1999. All rights reserved. Printed in Japan.

HITACHI

This datasheet has been downloaded from:

www.DatasheetCatalog.com

Datasheets for electronic components.



LittleDiode supplies new, hard to find or obsolete electronic components and semiconductors all over the world.

With over two million different components listed you are sure to find the part you need.

Feel free to visit us today at our online store:

LittleDiode.com

Looking forward to providing you with the best possible service.