

SN74LS122 SN74LS123

Retriggerable Monostable Multivibrators

These dc triggered multivibrators feature pulse width control by three methods. The basic pulse width is programmed by selection of external resistance and capacitance values. The LS122 has an internal timing resistor that allows the circuits to be used with only an external capacitor. Once triggered, the basic pulse width may be extended by retriggering the gated low-level-active (A) or high-level-active (B) inputs, or be reduced by use of the overriding clear.

- Overriding Clear Terminates Output Pulse
- Compensated for V_{CC} and Temperature Variations
- DC Triggered from Active-High or Active-Low Gated Logic Inputs
- Retriggerable for Very Long Output Pulses, up to 100% Duty Cycle
- Internal Timing Resistors on LS122

GUARANTEED OPERATING RANGES

Symbol	Parameter	Min	Typ	Max	Unit
V_{CC}	Supply Voltage	4.75	5.0	5.25	V
T_A	Operating Ambient Temperature Range	0	25	70	°C
I_{OH}	Output Current – High			-0.4	mA
I_{OL}	Output Current – Low			8.0	mA
R_{ext}	External Timing Resistance	5.0		260	k Ω
C_{ext}	External Capacitance	No Restriction			
R_{ext}/C_{ext}	Wiring Capacitance at R_{ext}/C_{ext} Terminal			50	pF



ON Semiconductor

Formerly a Division of Motorola

<http://onsemi.com>

LOW POWER SCHOTTKY

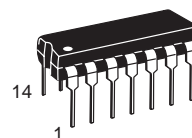

PLASTIC
N SUFFIX
CASE 646

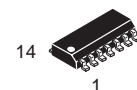

SOIC
D SUFFIX
CASE 751A

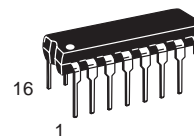

PLASTIC
N SUFFIX
CASE 648

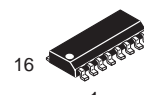

SOIC
D SUFFIX
CASE 751B

ORDERING INFORMATION

Device	Package	Shipping
SN74LS122N	14 Pin DIP	2000 Units/Box
SN74LS122D	14 Pin	2500/Tape & Reel
SN74LS123N	16 Pin DIP	2000 Units/Box
SN74LS123D	16 Pin	2500/Tape & Reel

SN74LS122 SN74LS123

SN74LS123 (TOP VIEW) (SEE NOTES 1 THRU 4)

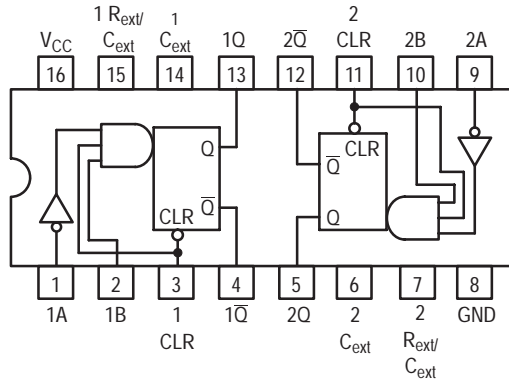

SN74LS122 (TOP VIEW) (SEE NOTES 1 THRU 4)

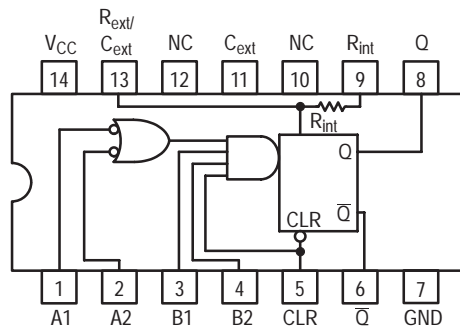

NC — NO INTERNAL CONNECTION.

NOTES:

1. An external timing capacitor may be connected between C_{ext} and R_{ext}/C_{ext} (positive).
2. To use the internal timing resistor of the LS122, connect R_{int} to V_{CC} .
3. For improved pulse width accuracy connect an external resistor between R_{ext}/C_{ext} and V_{CC} with R_{int} open-circuited.
4. To obtain variable pulse widths, connect an external variable resistance between R_{int}/C_{ext} and V_{CC} .

SN74LS122 SN74LS123

LS122 FUNCTIONAL TABLE

INPUTS				OUTPUTS		
CLEAR	A1	A2	B1	B2	Q	\bar{Q}
L	X	X	X	X	L	H
X	H	H	X	X	L	H
X	X	X	L	X	L	H
X	X	X	X	L	L	H
H	L	X	↑	H		
H	L	X	H	↑		
H	X	L	↑	H		
H	X	L	H	↑		
H	H	↓	H	H		
H	↓	↓	H	H		
H	↓	H	H	H		
↑	L	X	H	H		
↑	X	L	H	H		

LS123 FUNCTIONAL TABLE

INPUTS			OUTPUTS	
CLEAR	A	B	Q	\bar{Q}
L	X	X	L	H
X	H	X	L	H
X	X	L	L	H
H	L	↑		
H	↓	H		
↑	L	H		

TYPICAL APPLICATION DATA

The output pulse t_W is a function of the external components, C_{ext} and R_{ext} or C_{ext} and R_{int} on the LS122. For values of $C_{ext} \geq 1000$ pF, the output pulse at $V_{CC} = 5.0$ V and $V_{RC} = 5.0$ V (see Figures 1, 2, and 3) is given by

$$t_W = K R_{ext} C_{ext} \text{ where } K \text{ is nominally } 0.45$$

If C_{ext} is in pF and R_{ext} is in $k\Omega$ then t_W is in nanoseconds.

The C_{ext} terminal of the LS122 and LS123 is an internal connection to ground, however for the best system performance C_{ext} should be hard-wired to ground.

Care should be taken to keep R_{ext} and C_{ext} as close to the monostable as possible with a minimum amount of inductance between the R_{ext}/C_{ext} junction and the R_{ext}/C_{ext} pin. Good groundplane and adequate bypassing should be designed into the system for optimum performance to ensure that no false triggering occurs.

It should be noted that the C_{ext} pin is internally connected to ground on the LS122 and LS123, but not on the LS221. Therefore, if C_{ext} is hard-wired externally to ground, substitution of a LS221 onto a LS123 socket will cause the LS221 to become non-functional.

The switching diode is not needed for electrolytic capacitance application and should not be used on the LS122 and LS123.

To find the value of K for $C_{ext} \geq 1000$ pF, refer to Figure 4. Variations on V_{CC} or V_{RC} can cause the value of K to change, as can the temperature of the LS123, LS122.

Figures 5 and 6 show the behavior of the circuit shown in Figures 1 and 2 if separate power supplies are used for V_{CC} and V_{RC} . If V_{CC} is tied to V_{RC} , Figure 7 shows how K will vary with V_{CC} and temperature. Remember, the changes in R_{ext} and C_{ext} with temperature are not calculated and included in the graph.

As long as $C_{ext} \geq 1000$ pF and $5K \leq R_{ext} \leq 260K$, the change in K with respect to R_{ext} is negligible.

If $C_{ext} \leq 1000$ pF the graph shown on Figure 8 can be used to determine the output pulse width. Figure 9 shows how K will change for $C_{ext} \leq 1000$ pF if V_{CC} and V_{RC} are connected to the same power supply. The pulse width t_W in nanoseconds is approximated by

$$t_W = 6 + 0.05 C_{ext} (\text{pF}) + 0.45 R_{ext} (k\Omega) C_{ext} + 11.6 R_{ext}$$

In order to trim the output pulse width, it is necessary to include a variable resistor between V_{CC} and the R_{ext}/C_{ext} pin or between V_{CC} and the R_{ext} pin of the LS122. Figure 10, 11, and 12 show how this can be done. R_{ext} remote should be kept as close to the monostable as possible.

Retriggering of the part, as shown in Figure 3, must not occur before C_{ext} is discharged or the retrigger pulse will not have any effect. The discharge time of C_{ext} in nanoseconds is guaranteed to be less than $0.22 C_{ext}$ (pF) and is typically $0.05 C_{ext}$ (pF).

For the smallest possible deviation in output pulse widths from various devices, it is suggested that C_{ext} be kept ≥ 1000 pF.

SN74LS122 SN74LS123

WAVEFORMS

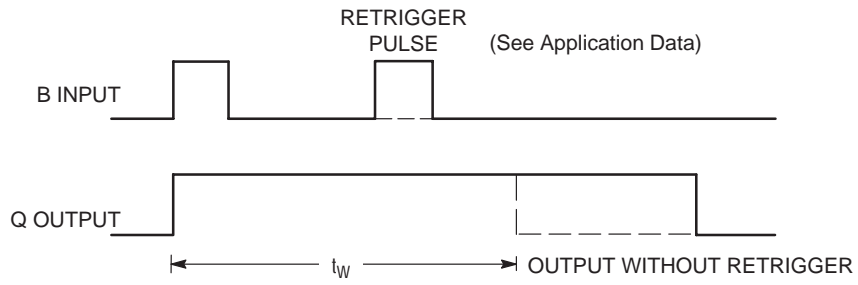

EXTENDING PULSE WIDTH

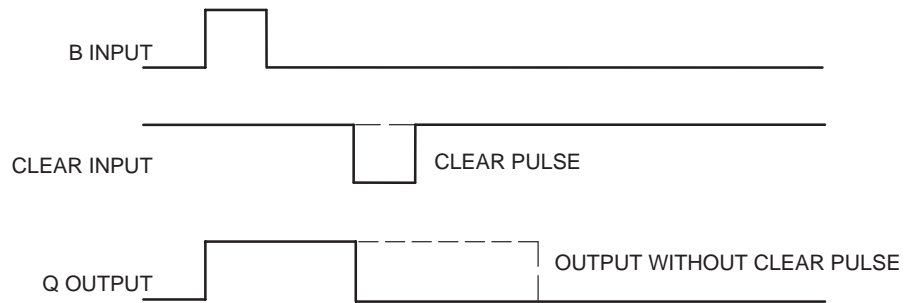

OVERRIDING THE OUTPUT PULSE

SN74LS122 SN74LS123

DC CHARACTERISTICS OVER OPERATING TEMPERATURE RANGE (unless otherwise specified)

Symbol	Parameter	Limits			Unit	Test Conditions
		Min	Typ	Max		
V _{IH}	Input HIGH Voltage	2.0			V	Guaranteed Input HIGH Voltage for All Inputs
V _{IL}	Input LOW Voltage			0.8	V	Guaranteed Input LOW Voltage for All Inputs
V _{IK}	Input Clamp Diode Voltage		-0.65	-1.5	V	V _{CC} = MIN, I _{IN} = -18 mA
V _{OH}	Output HIGH Voltage	2.7	3.5		V	V _{CC} = MIN, I _{OH} = MAX, V _{IN} = V _{IH} or V _{IL} per Truth Table
V _{OL}	Output LOW Voltage		0.25	0.4	V	I _{OL} = 4.0 mA V _{CC} = V _{CC} MIN, V _{IN} = V _{IL} or V _{IH} per Truth Table
			0.35	0.5	V	
I _{IH}	Input HIGH Current			20	μA	V _{CC} = MAX, V _{IN} = 2.7 V
				0.1	mA	V _{CC} = MAX, V _{IN} = 7.0 V
I _{IL}	Input LOW Current			-0.4	mA	V _{CC} = MAX, V _{IN} = 0.4 V
I _{OS}	Short Circuit Current (Note 1)	-20		-100	mA	V _{CC} = MAX
I _{CC}	Power Supply Current	LS122		11	mA	V _{CC} = MAX
		LS123		20		

Note 1: Not more than one output should be shorted at a time, nor for more than 1 second.

AC CHARACTERISTICS (T_A = 25°C, V_{CC} = 5.0 V)

Symbol	Parameter	Limits			Unit	Test Conditions
		Min	Typ	Max		
t _{PLH} t _{PHL}	Propagation Delay, A to Q Propagation Delay, A to \bar{Q}		23 32	33 45	ns	C _{ext} = 0 C _L = 15 pF R _{ext} = 5.0 kΩ R _L = 2.0 kΩ
t _{PLH} t _{PHL}	Propagation Delay, B to Q Propagation Delay, B to \bar{Q}		23 34	44 56		
t _{PLH} t _{PHL}	Propagation Delay, Clear to \bar{Q} Propagation Delay, Clear to Q		28	45	ns	
			20	27		
t _{W min}	A or B to Q		116	200	ns	
t _{WQ}	A to B to Q	4.0	4.5	5.0	μs	

AC SETUP REQUIREMENTS (T_A = 25°C, V_{CC} = 5.0 V)

Symbol	Parameter	Limits			Unit	Test Conditions
		Min	Typ	Max		
t _W	Pulse Width	40			ns	

SN74LS122 SN74LS123

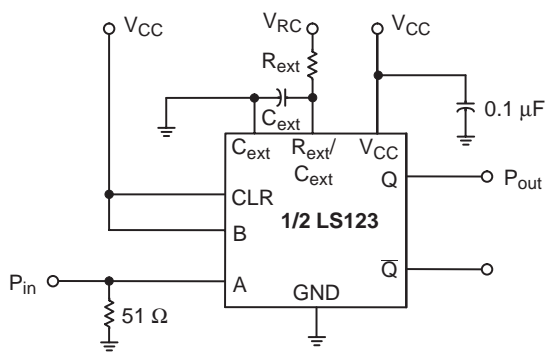

Figure 1.

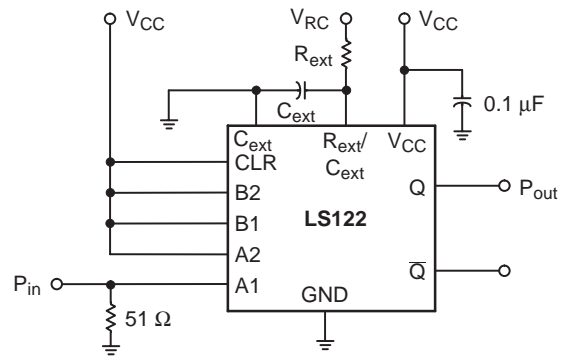

Figure 2.

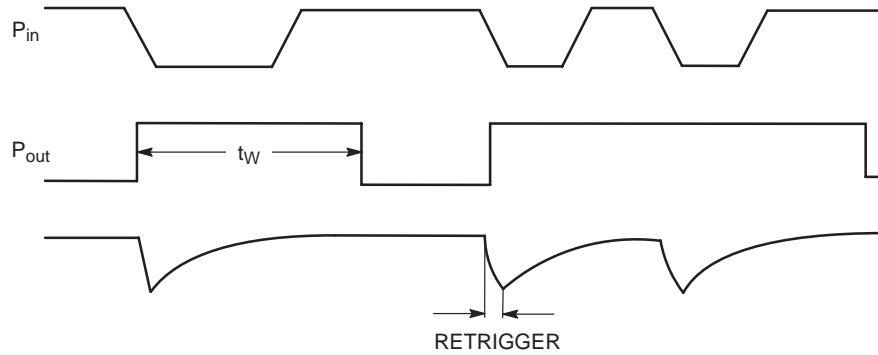

Figure 3.

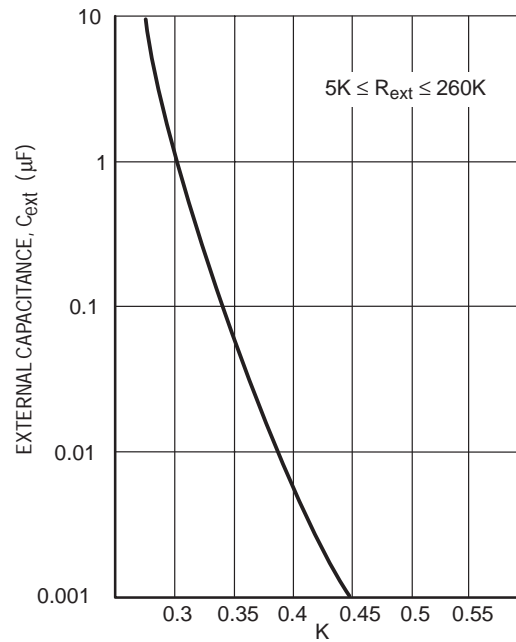

Figure 4.

SN74LS122 SN74LS123

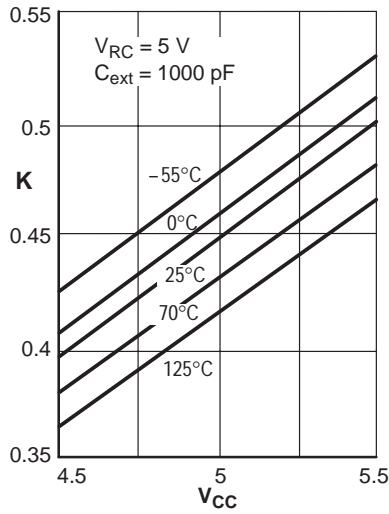

Figure 5. K versus V_{CC}

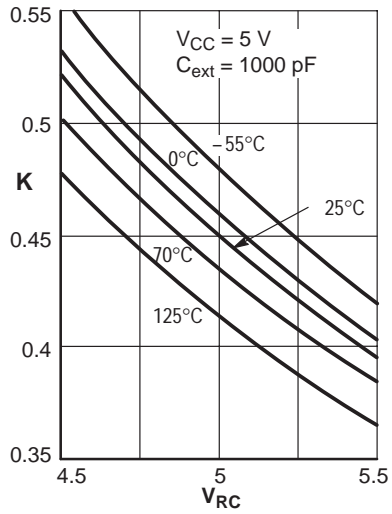

Figure 6. K versus V_{RC}

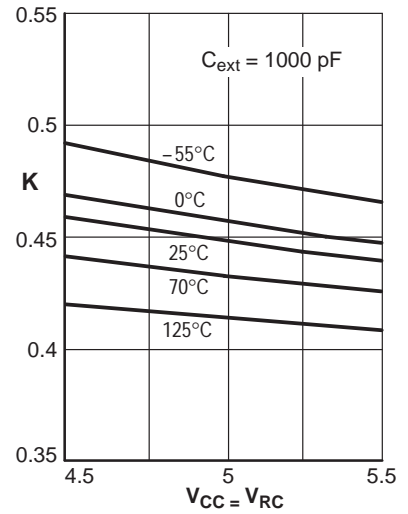

Figure 7. K versus V_{CC} and V_{RC}

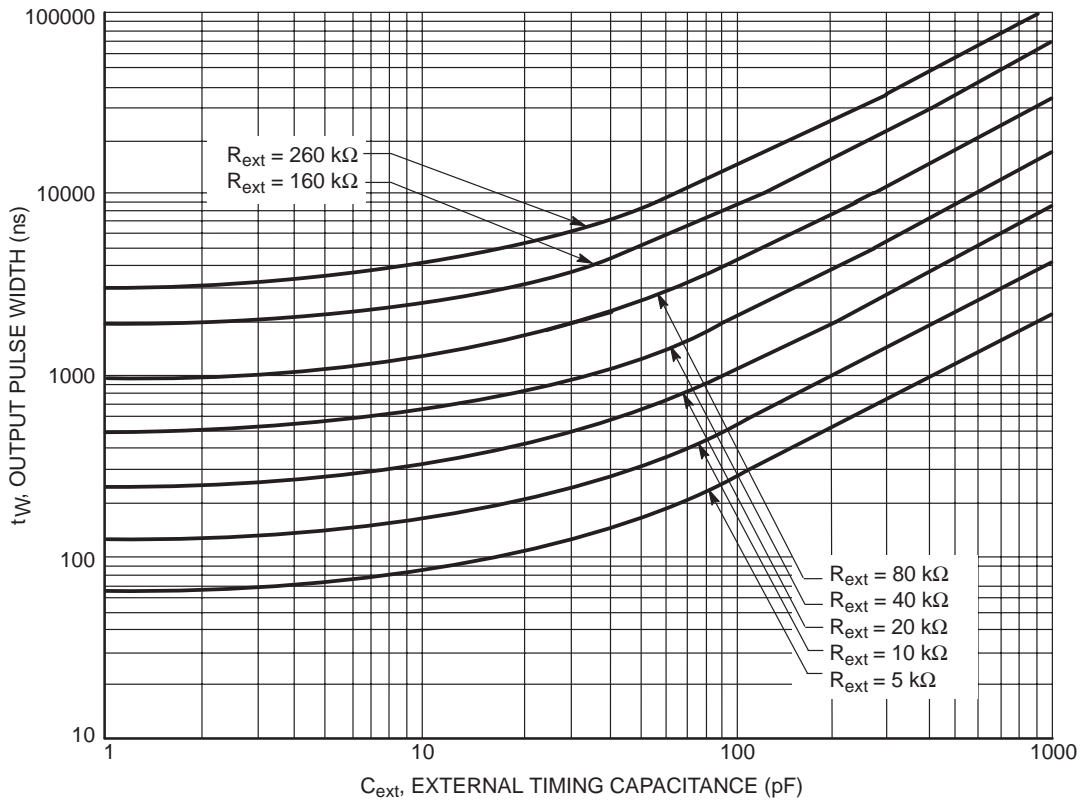

Figure 8.

SN74LS122 SN74LS123

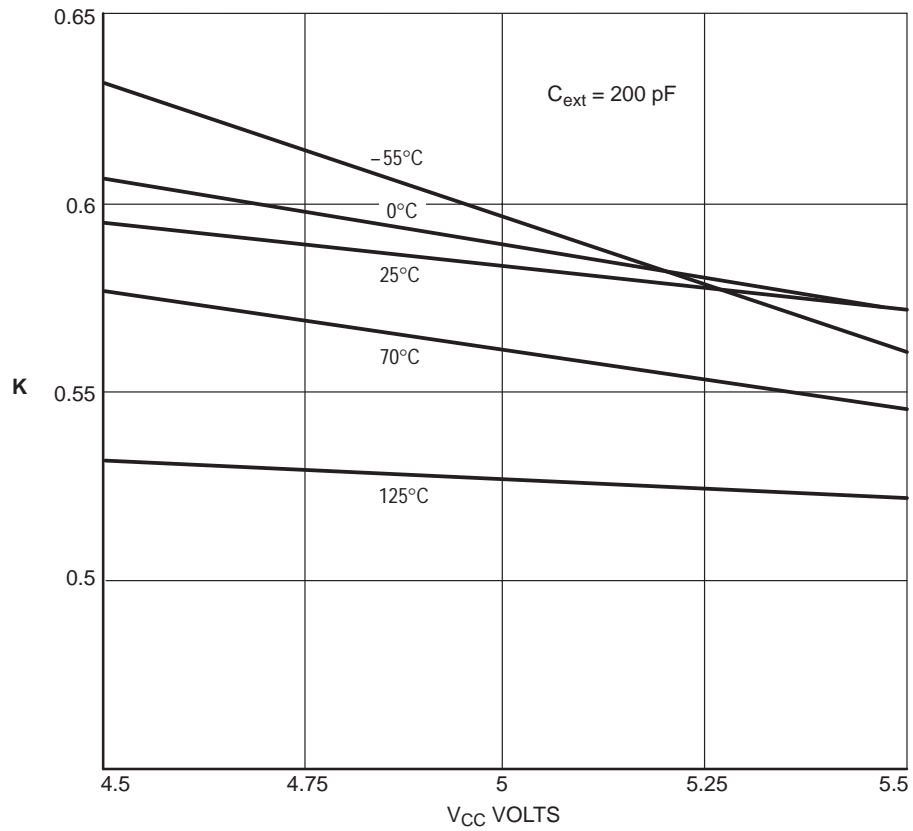

Figure 9.

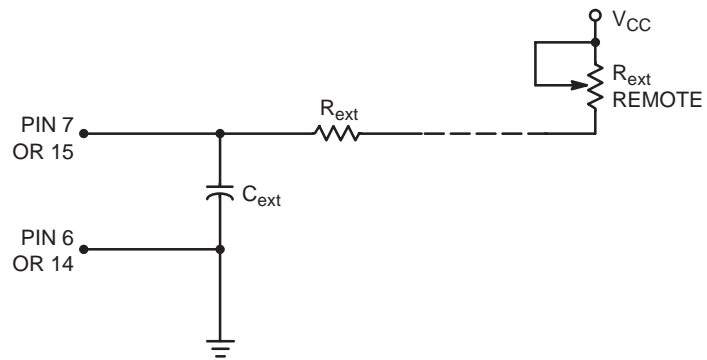

Figure 10. LS123 Remote Trimming Circuit

SN74LS122 SN74LS123

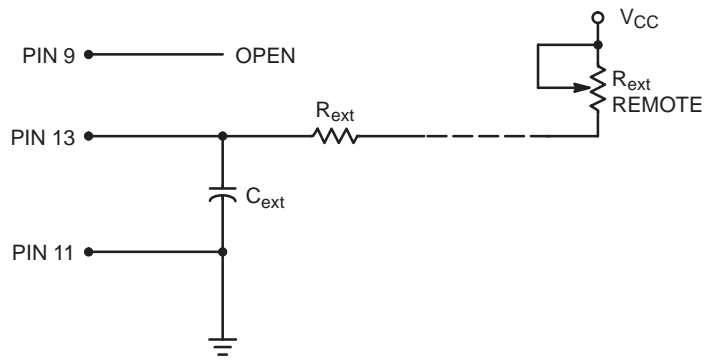

Figure 11. LS122 Remote Trimming Circuit Without R_{ext}

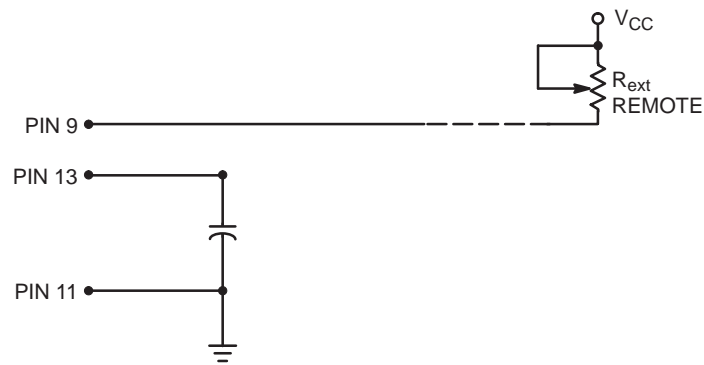
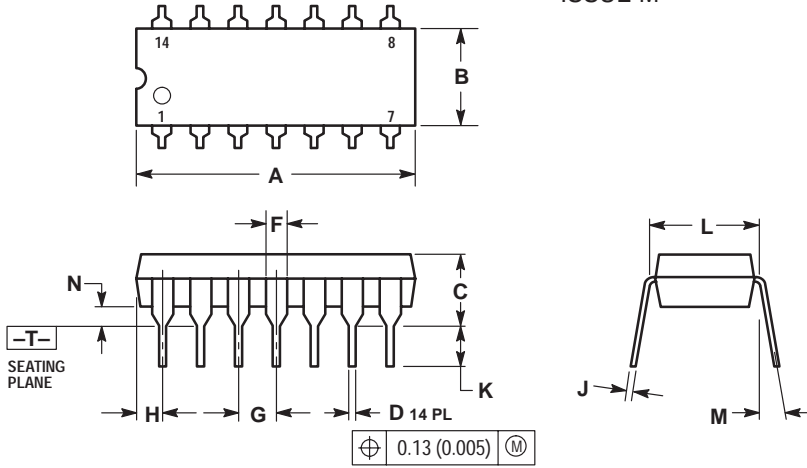

Figure 12. LS122 Remote Trimming Circuit with R_{int}

SN74LS122 SN74LS123

PACKAGE DIMENSIONS

N SUFFIX PLASTIC PACKAGE CASE 646-06 ISSUE M



NOTES:

1. DIMENSIONING AND TOLERANCING PER ANSI Y14.5M, 1982.
2. CONTROLLING DIMENSION: INCH.
3. DIMENSION L TO CENTER OF LEADS WHEN FORMED PARALLEL.
4. DIMENSION B DOES NOT INCLUDE MOLD FLASH.
5. ROUNDED CORNERS OPTIONAL.

DIM	INCHES		MILLIMETERS	
	MIN	MAX	MIN	MAX
A	0.715	0.770	18.16	18.80
B	0.240	0.260	6.10	6.60
C	0.145	0.185	3.69	4.69
D	0.015	0.021	0.38	0.53
F	0.040	0.070	1.02	1.78
G	0.100 BSC		2.54 BSC	
H	0.052	0.095	1.32	2.41
J	0.008	0.015	0.20	0.38
K	0.115	0.135	2.92	3.43
L	0.290	0.310	7.37	7.87
M	---	10°	---	10°
N	0.015	0.039	0.38	1.01

D SUFFIX PLASTIC SOIC PACKAGE CASE 751A-03 ISSUE F

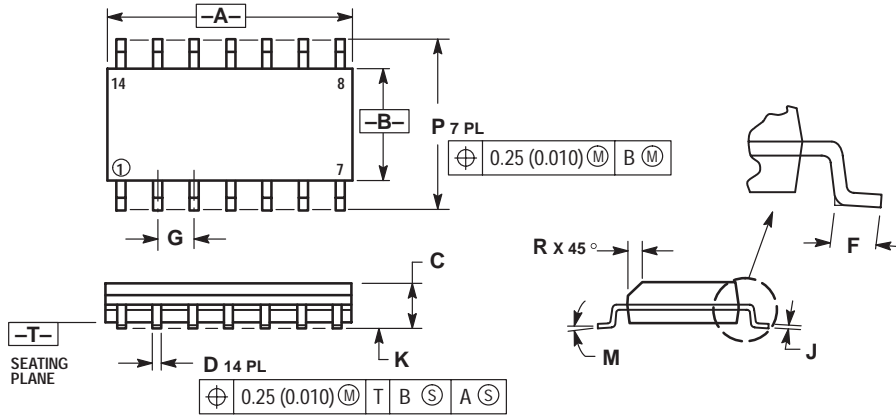

NOTES:

1. DIMENSIONING AND TOLERANCING PER ANSI Y14.5M, 1982.
2. CONTROLLING DIMENSION: MILLIMETER.
3. DIMENSIONS A AND B DO NOT INCLUDE MOLD PROTRUSION.
4. MAXIMUM MOLD PROTRUSION 0.15 (0.006) PER SIDE.
5. DIMENSION D DOES NOT INCLUDE DAMBAR PROTRUSION. ALLOWABLE DAMBAR PROTRUSION SHALL BE 0.127 (0.005) TOTAL IN EXCESS OF THE D DIMENSION AT MAXIMUM MATERIAL CONDITION.

DIM	MILLIMETERS		INCHES	
	MIN	MAX	MIN	MAX
A	8.55	8.75	0.337	0.344
B	3.80	4.00	0.150	0.157
C	1.35	1.75	0.054	0.068
D	0.35	0.49	0.014	0.019
F	0.40	1.25	0.016	0.049
G	1.27 BSC		0.050 BSC	
J	0.19	0.25	0.008	0.009
K	0.10	0.25	0.004	0.009
M	0°	7°	0°	7°
P	5.80	6.20	0.228	0.244
R	0.25	0.50	0.010	0.019

SN74LS123 SN74LS123

PACKAGE DIMENSIONS

N SUFFIX PLASTIC PACKAGE CASE 648-08 ISSUE R

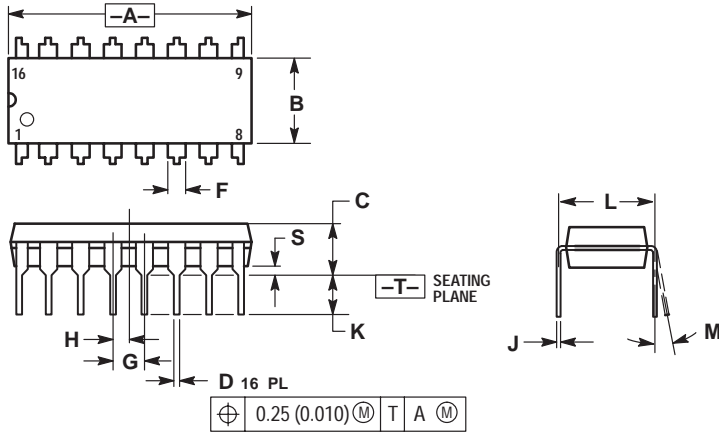

NOTES:

1. DIMENSIONING AND TOLERANCING PER ANSI Y14.5M, 1982.
2. CONTROLLING DIMENSION: INCH.
3. DIMENSION L TO CENTER OF LEADS WHEN FORMED PARALLEL.
4. DIMENSION B DOES NOT INCLUDE MOLD FLASH.
5. ROUNDED CORNERS OPTIONAL.

DIM	INCHES		MILLIMETERS	
	MIN	MAX	MIN	MAX
A	0.740	0.770	18.80	19.55
B	0.250	0.270	6.35	6.85
C	0.145	0.175	3.69	4.44
D	0.015	0.021	0.39	0.53
F	0.040	0.70	1.02	1.77
G	0.100 BSC		2.54 BSC	
H	0.050 BSC		1.27 BSC	
J	0.008	0.015	0.21	0.38
K	0.110	0.130	2.80	3.30
L	0.295	0.305	7.50	7.74
M	0° 10°		0° 10°	
S	0.020	0.040	0.51	1.01

D SUFFIX PLASTIC SOIC PACKAGE CASE 751B-05 ISSUE J

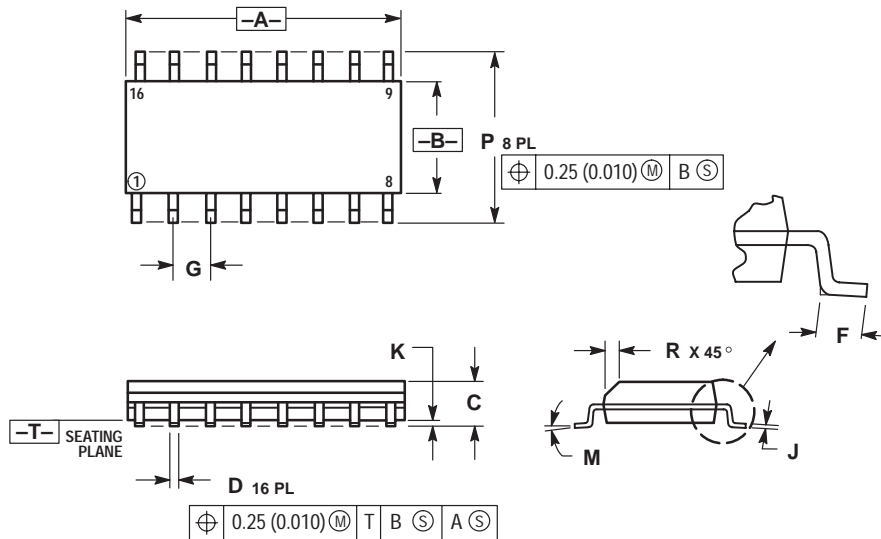

NOTES:

1. DIMENSIONING AND TOLERANCING PER ANSI Y14.5M, 1982.
2. CONTROLLING DIMENSION: MILLIMETER.
3. DIMENSIONS A AND B DO NOT INCLUDE MOLD PROTRUSION.
4. MAXIMUM MOLD PROTRUSION 0.15 (0.006) PER SIDE.
5. DIMENSION D DOES NOT INCLUDE DAMBAR PROTRUSION. ALLOWABLE DAMBAR PROTRUSION SHALL BE 0.127 (0.005) TOTAL IN EXCESS OF THE D DIMENSION AT MAXIMUM MATERIAL CONDITION.

DIM	MILLIMETERS		INCHES	
	MIN	MAX	MIN	MAX
A	9.80	10.00	0.386	0.393
B	3.80	4.00	0.150	0.157
C	1.35	1.75	0.054	0.068
D	0.35	0.49	0.014	0.019
F	0.40	1.25	0.016	0.049
G	1.27 BSC		0.050 BSC	
J	0.19	0.25	0.008	0.009
K	0.10	0.25	0.004	0.009
M	0° 7°		0° 7°	
P	5.80	6.20	0.229	0.244
R	0.25	0.50	0.010	0.019

ON Semiconductor and  are trademarks of Semiconductor Components Industries, LLC (SCILLC). SCILLC reserves the right to make changes without further notice to any products herein. SCILLC makes no warranty, representation or guarantee regarding the suitability of its products for any particular purpose, nor does SCILLC assume any liability arising out of the application or use of any product or circuit, and specifically disclaims any and all liability, including without limitation special, consequential or incidental damages. "Typical" parameters which may be provided in SCILLC data sheets and/or specifications can and do vary in different applications and actual performance may vary over time. All operating parameters, including "Typicals" must be validated for each customer application by customer's technical experts. SCILLC does not convey any license under its patent rights nor the rights of others. SCILLC products are not designed, intended, or authorized for use as components in systems intended for surgical implant into the body, or other applications intended to support or sustain life, or for any other application in which the failure of the SCILLC product could create a situation where personal injury or death may occur. Should Buyer purchase or use SCILLC products for any such unintended or unauthorized application, Buyer shall indemnify and hold SCILLC and its officers, employees, subsidiaries, affiliates, and distributors harmless against all claims, costs, damages, and expenses, and reasonable attorney fees arising out of, directly or indirectly, any claim of personal injury or death associated with such unintended or unauthorized use, even if such claim alleges that SCILLC was negligent regarding the design or manufacture of the part. SCILLC is an Equal Opportunity/Affirmative Action Employer.

PUBLICATION ORDERING INFORMATION

North America Literature Fulfillment:

Literature Distribution Center for ON Semiconductor
P.O. Box 5163, Denver, Colorado 80217 USA
Phone: 303-675-2175 or 800-344-3860 Toll Free USA/Canada
Fax: 303-675-2176 or 800-344-3867 Toll Free USA/Canada
Email: ONlit@hibbertco.com

N. American Technical Support: 800-282-9855 Toll Free USA/Canada

EUROPE: LDC for ON Semiconductor – European Support

German Phone: (+1) 303-308-7140 (M-F 2:30pm to 5:00pm Munich Time)
Email: ONlit-german@hibbertco.com
French Phone: (+1) 303-308-7141 (M-F 2:30pm to 5:00pm Toulouse Time)
Email: ONlit-french@hibbertco.com
English Phone: (+1) 303-308-7142 (M-F 1:30pm to 5:00pm UK Time)
Email: ONlit@hibbertco.com

ASIA/PACIFIC: LDC for ON Semiconductor – Asia Support

Phone: 303-675-2121 (Tue-Fri 9:00am to 1:00pm, Hong Kong Time)
Toll Free from Hong Kong 800-4422-3781
Email: ONlit-asia@hibbertco.com

JAPAN: ON Semiconductor, Japan Customer Focus Center
4-32-1 Nishi-Gotanda, Shinagawa-ku, Tokyo, Japan 141-8549

Phone: 81-3-5487-8345
Email: r14153@onsemi.com

Fax Response Line: 303-675-2167
800-344-3810 Toll Free USA/Canada

ON Semiconductor Website: <http://onsemi.com>

For additional information, please contact your local
Sales Representative.

This datasheet has been downloaded from:

www.DatasheetCatalog.com

Datasheets for electronic components.



LittleDiode supplies new, hard to find or obsolete electronic components and semiconductors all over the world.

With over two million different components listed you are sure to find the part you need.

Feel free to visit us today at our online store:

LittleDiode.com

Looking forward to providing you with the best possible service.